

Building connections that last™



Sharpe® Series 10

Two-Piece Brass Ball Valve

Datasheet



Two-Piece Brass Ball Valve Sharpe® Series 10



Design Features

- Full Port
- 600 CWP
- Forged Brass
- Threaded End Connections
- Blow-Out Proof Stem
- Lockable Lever Handle

Applicable Standards

- Threaded Ends ASME B16.11

Options

- Lockable Oval Handle



Two-Piece Brass Ball Valve
Sharpe® Series 10

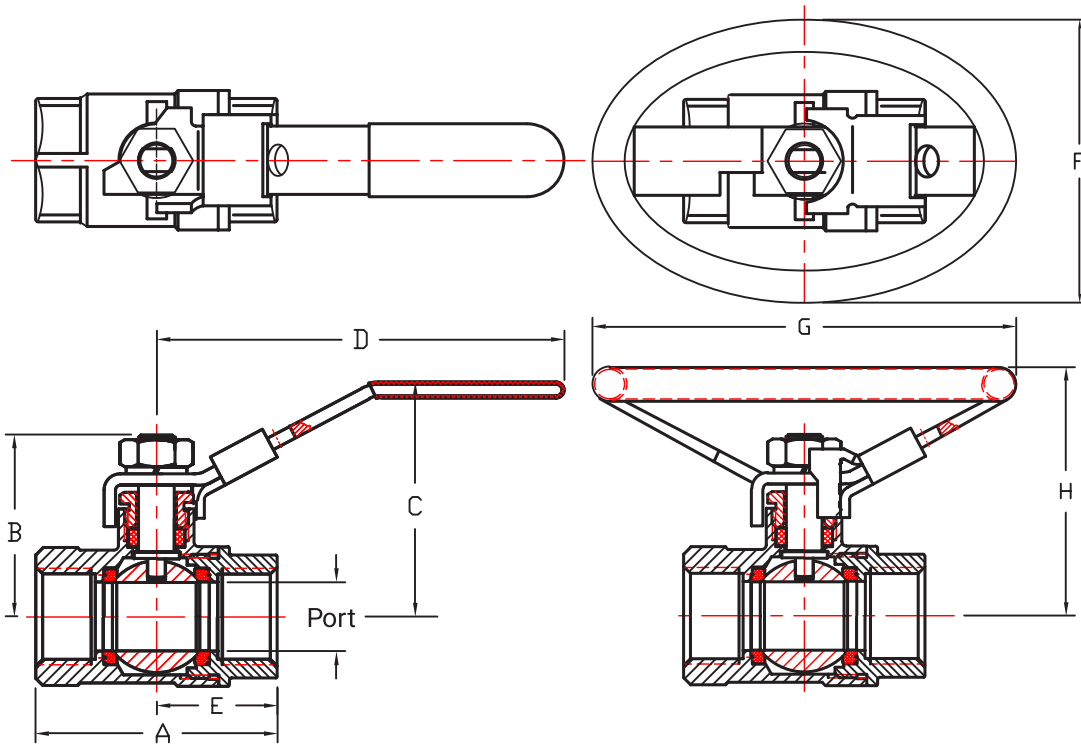

Dimensions (Inches)

| Size | Port | A | B | C | D | E | F | G | H |
|-------|------|------|------|------|-------|------|------|------|------|
| 1/4 | 0.39 | 1.70 | 1.22 | 1.71 | 4.13 | 0.85 | 2.36 | 3.62 | 1.34 |
| 3/8 | 0.39 | 1.70 | 1.22 | 1.71 | 4.13 | 0.85 | 2.36 | 3.62 | 1.34 |
| 1/2 | 0.59 | 2.07 | 1.57 | 2.04 | 4.13 | 1.05 | 2.36 | 3.62 | 1.34 |
| 3/4 | 0.75 | 2.37 | 1.81 | 2.48 | 4.72 | 1.19 | 2.55 | 3.78 | 1.69 |
| 1 | 1.00 | 2.89 | 1.96 | 2.63 | 4.72 | 1.45 | 2.55 | 3.78 | 1.69 |
| 1-1/4 | 1.25 | 3.26 | 2.51 | 2.95 | 6.14 | 1.63 | 3.30 | 4.65 | 1.93 |
| 1-1/2 | 1.57 | 3.62 | 2.73 | 3.16 | 6.14 | 1.81 | 3.30 | 4.65 | 1.93 |
| 2 | 1.96 | 4.40 | 3.00 | 3.44 | 6.14 | 2.20 | 3.30 | 4.65 | 1.93 |
| 2-1/2 | 2.55 | 5.98 | 3.81 | 4.70 | 9.20 | 3.00 | - | - | - |
| 3 | 2.95 | 6.49 | 4.13 | 5.00 | 9.20 | 3.25 | - | - | - |
| 4 | 4.00 | 7.75 | 4.94 | 5.76 | 10.50 | 3.88 | - | - | - |

Two-Piece Brass Ball Valve Sharpe® Series 10

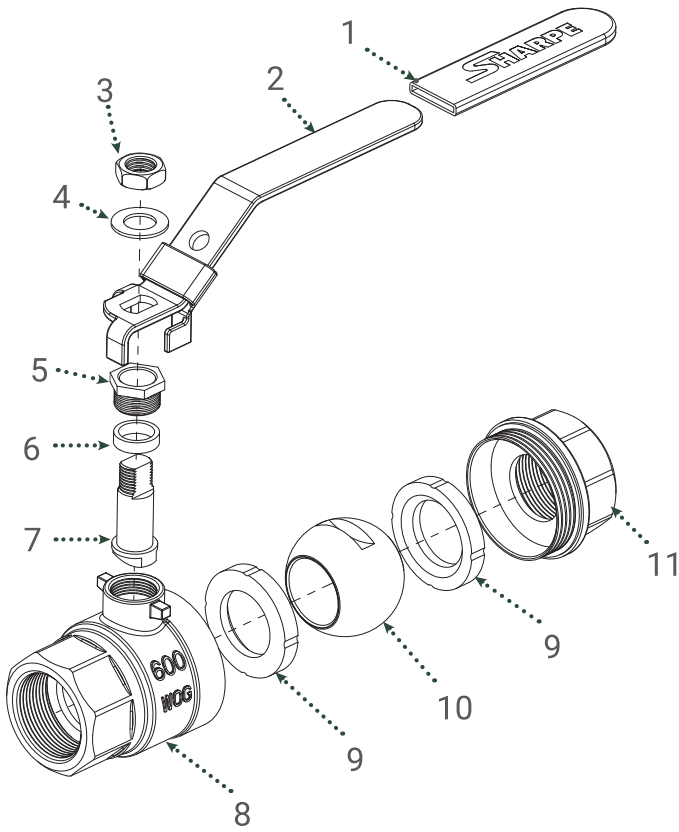

Parts & Materials

| No. | Part Name | Material. | Qty. |
|-----|---------------|---------------------|------|
| 1 | Handle Sleeve | PVC | 1 |
| 2 | Handle | Zinc Plated Steel | 1 |
| 3 | Handle Nut | Steel | 1 |
| 4 | Handle Washer | Steel | 1 |
| 5 | Packing Nut | Brass | 1 |
| 6 | Stem Packing | PTFE | 1 |
| 7 | Stem | Brass | 1 |
| 8 | Body | Forged Brass | 1 |
| 9 | Seat | PTFE | 2 |
| 10 | Ball | Chrome Plated Brass | 1 |
| 11 | End Piece | Forged Brass | 1 |

Two-Piece Brass Ball Valve

Sharpe® Series 10



Technical Information

| Size | C _v | Weight (lbs.) |
|-------|----------------|---------------|
| 1/4 | 5 | 0.40 |
| 3/8 | 5 | 0.33 |
| 1/2 | 24 | 0.53 |
| 3/4 | 35 | 0.75 |
| 1 | 47 | 1.00 |
| 1-1/4 | 81 | 1.72 |
| 1-1/2 | 105 | 2.25 |
| 2 | 240 | 3.48 |
| 2-1/2 | 320 | 7.80 |
| 3 | 580 | 8.93 |
| 4 | 970 | 17.00 |

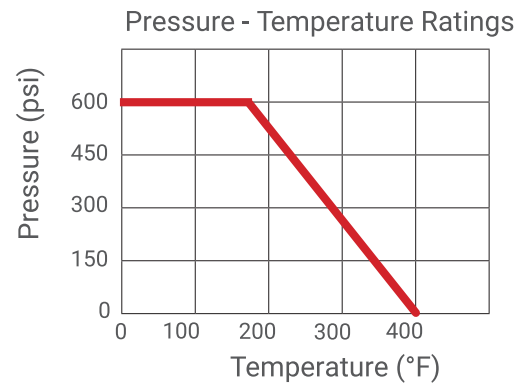

Two-Piece Brass Ball Valve
Sharpe® Series 10



How to order Series 10

Example 1½ 10-11T-TE

1½" 10 - 1 1 T - TE - = 1½ 10-11T-TE

| Size | Series | Body Material | Ball & Stem Material | Seat Material | End Style | Suffixes & Options |
|------|--------|---------------|----------------------|---------------|-------------|--------------------|
| Size | Series | Body Material | Ball & Stem Matl. | Seat Material | End Style | Options |
| ¼ | 10 | 1 Brass | 1 Brass | T PTFE | TE Threaded | OH Oval Handle |
| ¾ | | | | | | |
| ½ | | | | | | |
| ¾ | | | | | | |
| 1 | | | | | | |
| 1-¼ | | | | | | |
| 1-½ | | | | | | |
| 2 | | | | | | |
| 2-½ | | | | | | |
| 3 | | | | | | |
| 4 | | | | | | |

Note:
 Responsibility for proper selection, use and maintenance of any product remains solely with the purchaser and end user. We reserve the right to modify or improve the designs or specifications of any product, at any time without notice.

About ASC Engineered Solutions

ASC Engineered Solutions is defined by quality—in its products, services and support. With more than 1,400 employees, the company's portfolio of precision-engineered piping support, valves and connections provides products to more than 4,000 customers across industries, such as mechanical, industrial, fire protection, oil and gas, and commercial and residential construction. Its portfolio of leading brands includes ABZ Valve®, AFCON®, Anvil®, Anvil EPS, Anvil Services, Basic-PSA, Beck®, Catawissa, Cooplet®, FlexHead®, FPPI®, Gruklok®, J.B. Smith, Merit®, North Alabama Pipe, Quadrant®, SCI®, Sharpe®, SlideLOK®, SPF® and SprinkFLEX®. With headquarters in Commerce, CA, and Exeter, NH, ASC also has ISO 9001:2015 certified production facilities in PA, TN, IL, TX, AL, LA, KS, and RI.



asc-es.com

Building connections that last™

FC-DS-SERIES 10-v02 20220308

