

Building connections that last™

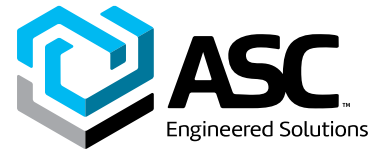

Sharpe® Series 4x4®

Pneumatic Actuator Datasheet



4x4 Pneumatic Actuator

Why Smaller Is Better

The Sharpe® Pneumatic Actuator Series 4x4® packs more than double the torque of conventional rack and pinion actuators. Due to its four pistons that generate torque around a centrally located pinion. With more pistons in the actuator, it allows their diameter to be smaller while generating higher torque. At the same time, it means the size of the actuator can be more compact.

Why Smaller Is Faster

With four small cylinders each located on one of four sides of the unit and at a given air pressure, the 4x4® produces the same torque output as double piston models using smaller diameter pistons and a narrower pinion. Thanks to the narrower pinion, the pistons travel shorter distances so that they can move faster from one position to the next.

Why Smaller Reduces Air Consumption

The cube shape coupled with pistons traveling shorter distances minimizes size requirements while maximizing torque output. At the same time, shorter piston travel and compact size greatly reduces pressure requirements compared to other designs and results in reduced energy expenditures.



Why Smaller Means Less Stress

It's a matter of balance. Unlike other designs that produce an off-axis thrust, the 4x4® design positions each piston around the cube so they develop thrust along their own axis. As a result, stressful piston side loading is minimized, putting less stress on seals resulting in less wear.

Why Smaller Is A Better Solution

Because of the four-cylinder design, the 4x4® has many more spring combination possibilities than double piston actuators. This means better solutions under any air pressure requirement. Each chamber can use up to three different spring sizes which nest between the covers and pistons and align by centering rings. Also, springs are wound in opposite directions to avoid tangles during operation.

Why Smaller Is Stronger

For superior corrosion resistance, the body and covers are anodized internally and externally. Plus, they have an external epoxy base layer and a second polyurethane paint to further reduce corrosion in demanding applications. Extended spray wash downs do not create corrosion problems for the actuator.



4x4 Material Listing

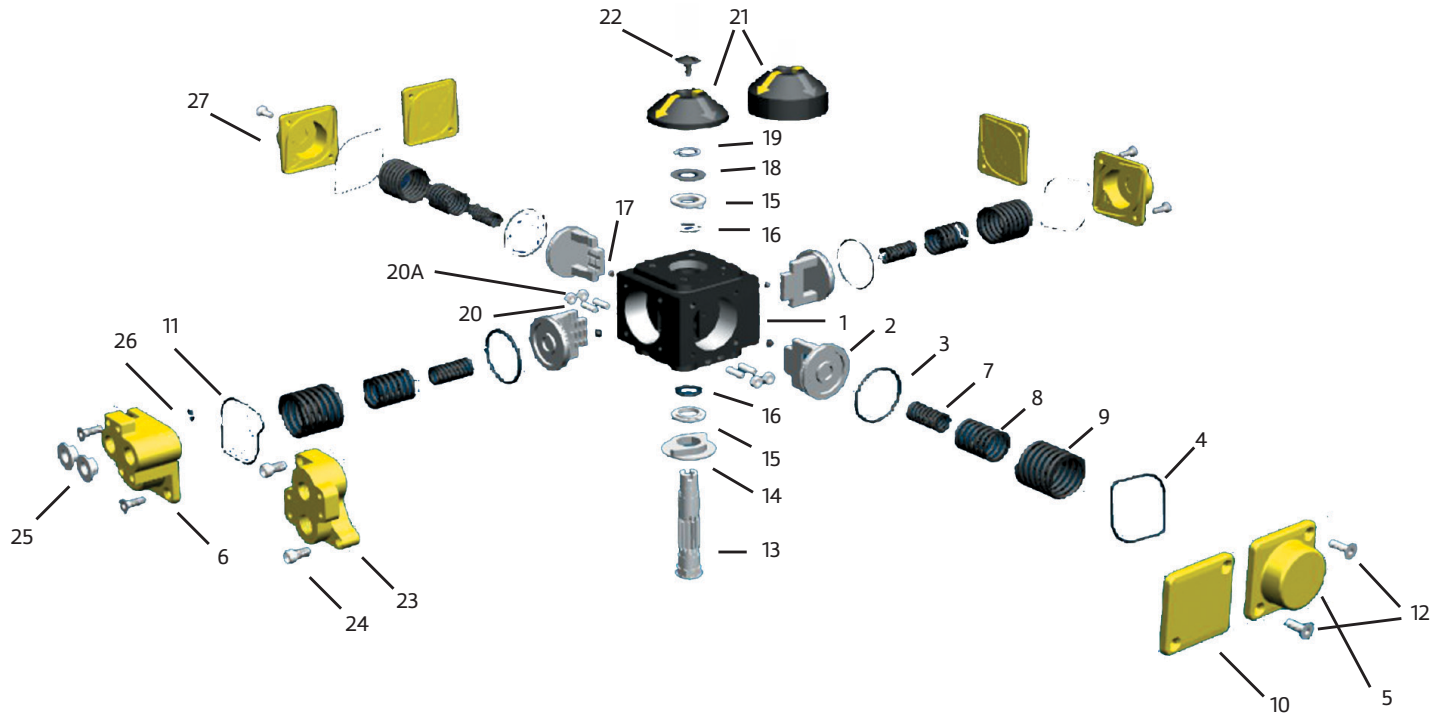

Parts & Materials

Part No.	Qty.	Part Description	Standard Materials	Part No.	Qty.	Part Description	Standard Materials
1	1	Body	Aluminum AL 356-T6	15*	2	Thrust Washer	POM
2	4	Piston	Carbon Steel S45C Nickel Plated	16*	2	Pinion "O" Ring	NBR
3*	4	Piston "O" Ring	NBR	17*	4	Pad	POM
4*	3	Cover "O" Ring	NBR	18	1	Disc Bearing	Stainless Steel 304
5	3	Spring Return Cover	Aluminum AL 380	19	1	Snap Ring	Stainless Steel 304
6	1	NAMUR Cover	Aluminum AL 380	20	4	Stroke Adjustment Stud	Stainless Steel 304
7	Max 4	Inner Spring	Painted Spring Steel	20A	4	Nut	Stainless Steel 304
8	Max 4	Middle Spring	Painted Spring Steel	21	1	Indicator	ABS
9	Max 4	Outer Spring	Painted Spring Steel	22	1	Indicator Screw	C15
10	3	Double Acting Cover	Aluminum AL 380	23	1	NAMUR Insert (X115)	AL 380
11	1	NAMUR Cover "O" Ring	NBR	24	2	Bolt (X115)	Stainless Steel 304
12	8, 16 or 18	Cover Screw	Stainless Steel 304	25	2	Plug	Plastic
13	1	Pinion	Steel	26*	1	Air Supply "O" Ring	NBR
14	1	Stroke Adjustment Stop	Stainless Steel 304	27*	7 (X90) 8 (X115)	Small End Cap "O" Ring	NBR

Note:

*Parts typically supplied in service kits.

Pneumatic Actuator Sharpe® Series 4x4®

4x4 Dimensions

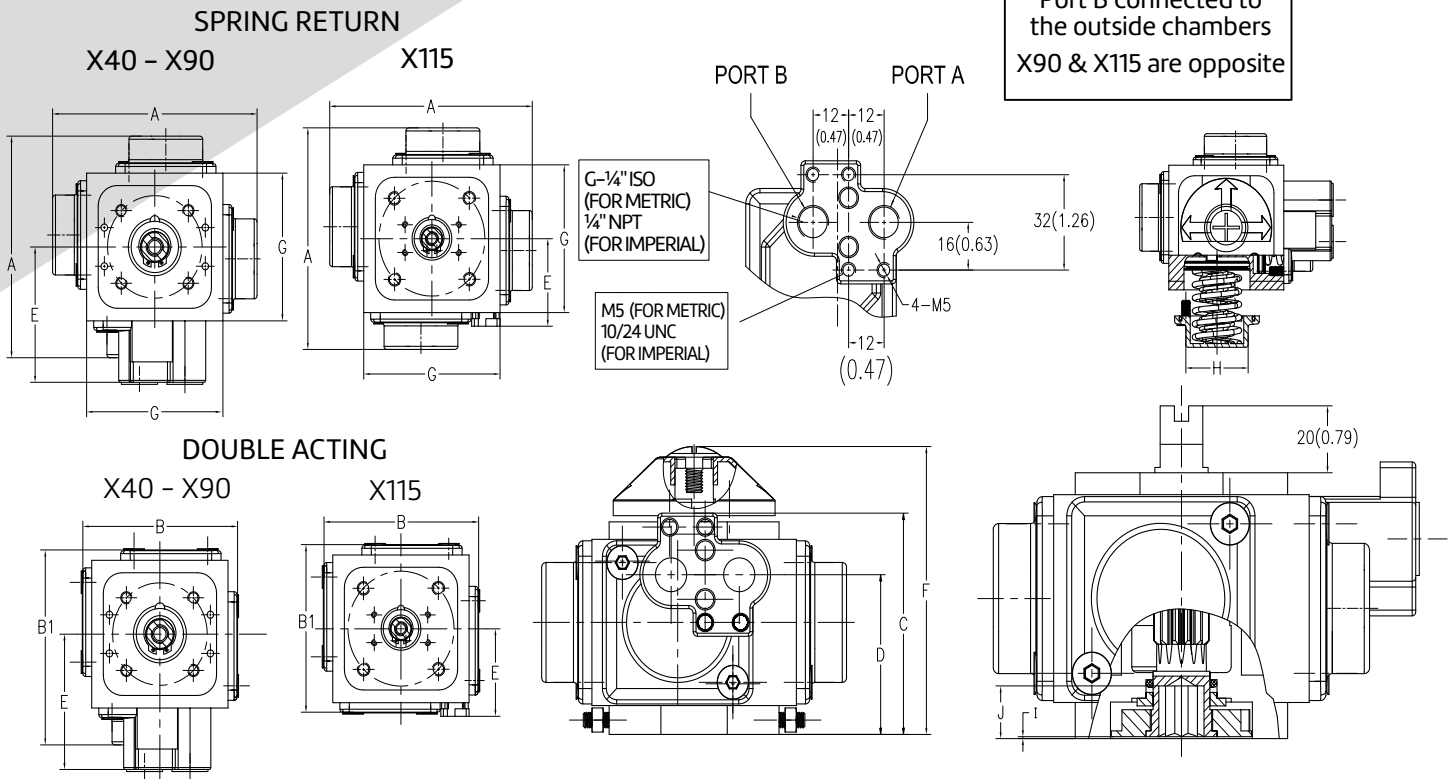

Dimensions

Size	Unit	A (S/R)	B (D/A)	B1 (D/A)	C	D	E	F	G	H	I	J
X40	in	4.26	3.31	3.78	2.73	2.04	2.60	3.65	2.84	1.61	0.02	0.55
	mm	108	84	96	69	52	66	92	72	40	0.5	14
X50	in	5.26	4.04	4.63	3.15	2.50	3.05	4.08	3.47	2.00	0.02	0.61
	mm	133	102	117	80	63	77	103	88	51	0.5	15
X60	in	6.38	5.20	5.79	3.86	3.02	3.53	4.73	4.26	2.50	0.02	0.77
	mm	162	132	147	98	77	89	120	108	63	0.5	20
X75	in	7.41	5.99	6.70	4.65	3.67	3.75	5.46	4.97	2.99	0.02	0.89
	mm	188	152	170	118	93	95	138	126	76	0.5	22
X90	in	8.75	7.17	7.96	5.36	4.04	4.49	6.17	5.91	3.59	0.02	1.04
	mm	222	182	202	136	102	114	156	150	91	0.5	26
X115	in	10.71	8.75	8.75	6.50	4.70	4.41	7.45	7.25	4.50	0.02	1.28
	mm	272	222	222	165	119	112	189	184	114	0.5	32

Pneumatic Actuator Sharpe® Series 4x4®

4x4 Dimensions

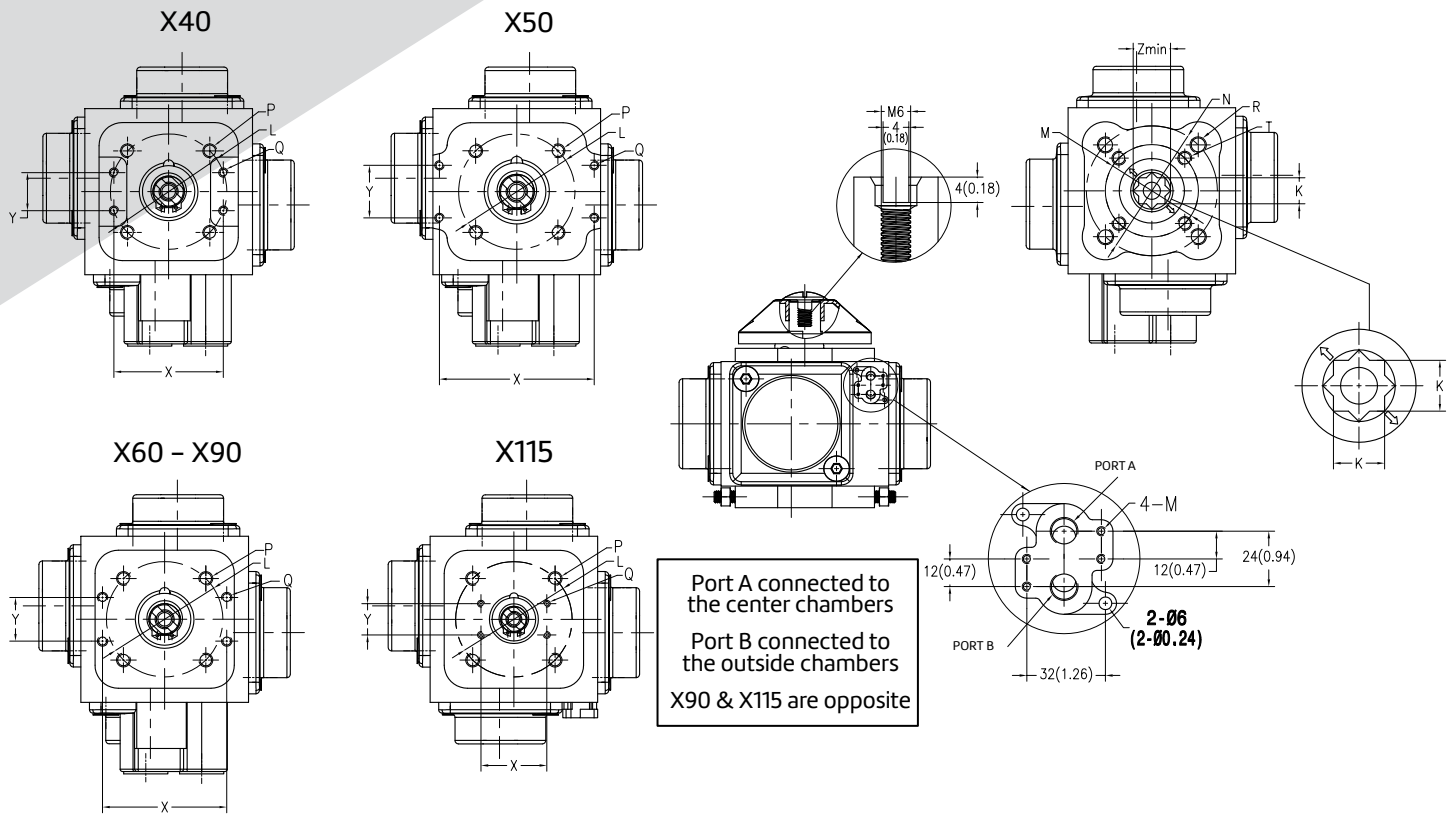

Dimensions

Size	Unit	K	L	M	N	P	Q	R	T	X	Y	Z (Min)
X40	in	0.35	F05	-	F04	-	-	-	-	1.85	0.67	0.48
	mm	9	F05	-	F04	M6	M4	M5	-	47	17	12
X50	in	0.43	F05	F05	F07	-	-	-	-	3.15	1.18	0.56
	mm	11	F05	F05	F07	M6	M5	M8	M6	80	30	14
X60	in	0.55	F07	F07	F10	-	-	-	-	3.15	1.18	0.72
	mm	14	F07	F07	F10	M8	M5	M10	M8	80	30	18
X75	in	0.67	F07	F07	F10	-	-	-	-	3.15	1.18	0.87
	mm	17	F07	F07	F10	M8	M5	M10	M8	80	30	22
X90	in	0.87	F10	-	F10	-	-	-	-	3.15	1.18	1.11
	mm	22	F10	-	F10	M10	M5	M10	-	80	30	28
X115	in	1.06	F12	-	F12	-	-	-	-	3.15	1.18	1.43
	mm	27	F12	-	F12	M12	M5	M12	-	80	30	36

4x4 Spring Arrangement

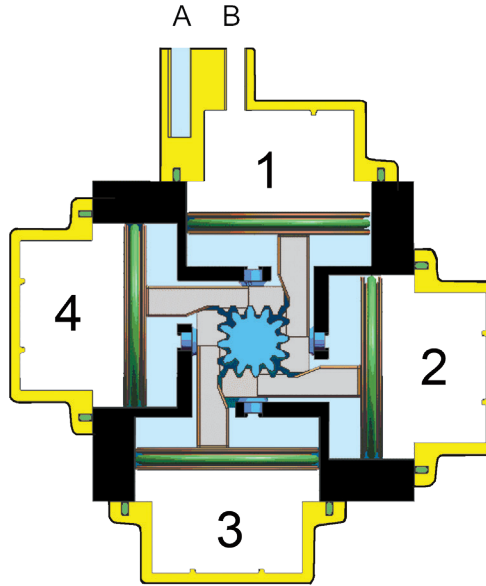

Spring Arrangement	Spring Position	Chamber			
		1	2	3	4
01	Inner	X	X	X	X
	Middle	-	-	-	-
	Outer	-	-	-	-
02	Inner	-	-	-	-
	Middle	X	X	X	X
	Outer	-	-	-	-
03	Inner	X	-	X	-
	Middle	X	X	X	X
	Outer	-	-	-	-
04	Inner	X	X	X	X
	Middle	X	X	X	X
	Outer	-	-	-	-
05	Inner	X	X	X	X
	Middle	-	X	-	X
	Outer	X	-	X	-

Spring Arrangement	Spring Position	Chamber			
		1	2	3	4
06	Inner	X	X	X	X
	Middle	-	-	-	-
	Outer	X	X	X	X
07	Inner	X	X	X	X
	Middle	X	X	X	X
	Outer	X	-	X	-
08	Inner	-	-	-	-
	Middle	X	X	X	X
	Outer	X	X	X	X
09	Inner	X	-	X	-
	Middle	X	X	X	X
	Outer	X	X	X	X
10	Inner	X	X	X	X
	Middle	X	X	X	X
	Outer	X	X	X	X

4x4 Torques

4x4 Spring Return Torques

Model	Spring Arrangement	Air Supply														Spring Return		
		40 psi		60 psi		70 psi		80 psi		90 psi		100 psi		120 psi				
		Start	End	Start	End	Start	End	Start	End	Start	End	Start	End	Start	End	Start	End	
X40	01	52	29	90	64	116	92	136	112	155	130	170	146	215	188	52	30	
	02			73	39	100	68	120	87	138	104	154	121	196	159	78	46	
	03					84	44	103	62	120	78	137	97	178	131	104	64	
	04									104	52	122	72	159	105	130	82	
X50	03	82	40	156	108	206	160	244	194	275	224	316	267	389	335	110	67	
	04			140	86	193	139	230	173	260	200	303	246	376	313	132	81	
	05			122	60	176	114	215	148	242	174	286	220	358	288	158	98	
	06					160	89	195	122	226	150	269	196	340	262	185	116	
	07					146	79	182	113	211	139	255	186	325	250	196	131	
	08							170	89	199	114	243	163	313	226	219	144	
	09									188	101	231	149	300	213	234	156	
	10									173	80	205	125	270	186	255	170	
	X60	03	204	119	347	249	439	343	519	417	590	485	672	570	818	723	205	118
		04			325	210	419	308	496	379	568	447	651	534	796	684	245	141
05				305	177	400	275	476	346	547	413	632	502	777	650	279	161	
06						373	237	450	306	520	372	606	462	749	609	320	188	
07						350	193	425	260	495	325	583	418	724	561	368	214	
08								400	219	470	284	559	379	699	519	409	238	
09										452	231	542	229	683	466	461	256	
10										430	192	521	291	660	426	501	277	
X75	03	235	212	563	432	729	600	859	722	976	834	1126	986	1382	1255	305	189	
	04	290	153	520	367	688	538	817	658	933	769	1085	924	1339	1189	370	232	
	05			475	270	646	448	772	563	888	673	1042	832	1294	1091	466	277	
	06			436	164	603	372	728	486	843	595	999	758	1249	1012	546	323	
	07					569	313	693	424	807	531	966	697	1214	948	610	358	
	08					552	216	657	348	772	454	931	624	1178	869	686	393	
	09									725	368	888	542	1132	781	774	440	
	10									681	297	845	474	1089	710	845	483	

4x4 Torques (Cont.)

4x4 Spring Return Torques																		
Model	Spring Arrangement	Air Supply														Spring Return		
		40 psi		60 psi		70 psi		80 psi		90 psi		100 psi		120 psi				
		Start	End	Start	End	Start	End	Start	End	Start	End	Start	End	Start	End	Start	End	
X90	03	656	405	1071	780	1346	1061	1559	1260	1748	1439	1995	1692	2428	2146	544	283	
	04			1014	678	1291	965	1502	1159	1690	1337	1940	1594	2371	2042	648	340	
	05			915	562	1198	855	1405	1045	1592	1221	1845	1484	2273	1925	963	439	
	06					1122	703	1326	888	1511	1061	1769	1332	2192	1762	924	519	
	07					1061	575	1263	754	1447	926	1708	1203	2129	1625	1065	582	
	08							1193	613	1376	782	1640	1065	2059	1478	1206	653	
	09									1298	579	1567	968	1980	1375	1309	730	
	10									1232	570	1504	864	1915	1264	1419	796	
	X115	03	1196	645	2019	1437	2542	1975	2968	2370	3347	2732	3820	3218	4652	4087	1167	643
		04			1890	1206	2419	1756	2841	2143	3218	2500	3697	2997	4524	3852	1400	772
05				1791	1027	2325	1586	2743	1967	3118	2322	3602	2827	4428	3670	1582	830	
06						2174	1318	2585	1687	2959	2038	3450	2558	4264	3382	1866	1030	
07						2051	1097	2458	1458	2828	1805	3325	2336	4136	3147	2100	1160	
08								2330	1230	2699	1574	3203	2115	4007	2910	2335	1289	
09										2573	1341	3083	1894	3881	2675	2568	1414	
10										2444	1110	2960	1673	3754	2440	2800	1543	

4x4 Double Acting Torque Ratings							
Model	40 psi	60 psi	70 psi	80 psi	90 psi	100 psi	120 psi
X40	79	119	137	178	192	218	238
X50	138	230	265	302	339	375	458
X60	315	470	550	657	725	799	959
X75	537	824	948	1074	1208	1340	1648
X90	920	1400	1666	2060	2130	2354	2893
X115	1953	2838	3322	3817	4302	4620	5401

4x4 Weights and Technical Information

4x4 Weights							
	Unit	X40	X50	X60	X75	X90	X115
Weight of Double Acting	Lb.	2.38	3.86	6.81	10.69	16.42	28.66
	Kg.	1.08	1.75	3.09	4.85	7.45	13.00
Weight of Double Acting with SR Cover (DS)	Lb.	2.42	3.96	6.97	11.16	17.17	29.78
	Kg.	1.10	1.80	3.16	5.06	7.79	13.51

Spring Set Code	Weight of Spring Return Actuator						
	Unit	X40	X50	X60	X75	X90	X115
01	Lb.	2.51	-	-	-	-	-
	Kg.	1.14	-	-	-	-	-
02	Lb.	2.60	-	-	-	-	-
	Kg.	1.18	-	-	-	-	-
03	Lb.	2.67	4.17	7.50	12.19	18.92	33.27
	Kg.	1.21	1.89	3.40	5.52	8.58	15.09
04	Lb.	2.73	4.21	7.58	12.35	19.22	33.91
	Kg.	1.24	1.91	3.44	5.60	8.72	15.38
05	Lb.	-	4.30	7.76	12.63	19.69	34.55
	Kg.	-	1.95	3.52	5.73	8.93	15.67
06	Lb.	-	4.39	7.94	12.92	20.15	35.19
	Kg.	-	1.99	3.60	5.86	9.14	15.96
07	Lb.	-	4.43	7.98	13.07	20.39	35.98
	Kg.	-	2.01	3.62	5.93	9.25	16.32
08	Lb.	-	4.52	8.20	13.47	20.92	36.77
	Kg.	-	2.05	3.72	6.11	9.49	16.68
09	Lb.	-	4.56	8.29	13.62	21.25	37.41
	Kg.	-	2.07	3.76	6.18	9.64	16.97
10	Lb.	-	4.63	8.38	13.78	21.56	38.03
	Kg.	-	2.10	3.80	6.25	9.78	17.25

4x4 Air Consumption & Opening and Closing Times							
	Unit	X40	X50	X60	X75	X90	X115
Air Consumption Per Stroke* Actual Volume - Liter	CCW	0.08	0.15	0.29	0.47	0.80	1.3
	CW	0.11	0.19	0.38	0.64	0.95	1.3
	Total	0.19	0.34	0.67	1.11	1.75	2.6
Air Consumption Per Stroke* Actual Volume - in³	CCW	4.9	9.2	16.2	28.7	46.3	79.3
	CW	6.7	11.6	21.3	35.1	52.3	82.6
	Total	11.6	20.7	37.5	63.8	98.6	161.9
Opening Time DA**	Sec.	0.15	0.21	0.39	0.53	1.10	1.60
Closing Time DA**	Sec.	0.16	0.24	0.41	0.54	1.30	1.80

Note:

*If you plan to use the actuator with the spring return cover as double acting actuator; please consult your representative for the air consumption figures.

** The above indicated moving time of the actuator, are obtained in the following testcons: (1) Room Temperature. (2) Actuator Stroke 90° (3) Solenoid Valve with orifice of 4mm and flow capacity Qn 400/L/min. (4) Inside pipe diameter 8mm, (5) Medium clean air, (6) Air supply pressure 5.5 bar (79, 75psi), (7) Actuator without external resistance load. Cautions: on the field applications when one or more of the above parameters are different, the moving time will be different.

4x4 Ordering Information

4x4 Sample Specification

Actuator shall be Sharpe® Automation X series (4x4®) with four piston design and function. Actuator will have epoxy coated endcaps, with hard anodized internally and externally extruded aluminum body. Internal parts to feature four carbon steel pistons for strength and have electroless nickel plating to inhibit corrosion. Actuator will have a higher torque output than other designs with comparable cylinder bores allowing for fitting of the smallest size possible.

With its smaller design air consumption will be reduced due to less open space in the actuator. Actuator will have four pistons supporting the pinion for less wear. With this design, torque output is maximized. With its design travel is reduced leading to quicker response and less wear to moving parts.

Springs are nested and wound in opposite direction to prevent binding. Since there are four chambers many spring combinations are available to fit air supply issues in the application. Independent travel stops allow adjustment +/- 5° in both opening and closing rotations.



All bottom bolting to ISO 5211 for ease of usage with valves / mounting kits of industry standards. Actuators to have NAMUR mount solenoid connections as well as other top mounted devices such as limit switches and positioners.

Lubrication to qualify for a minimum of 1,000,000 operations. Bearings, bushings and O-rings designed to maximize service life and prevent premature failure.

Fig: X90-SR-07-M

Description: X90 – Spring Return – 07 Spring Arrangement – Metric Units

How to order Series 4x4

4x4 Part Number Chart

Actuator Model	Action	Spring Arrangement	Insert	Options
X40	DA	Double Acting	01, 02 (X40 only)	M Metric P1 High / Low Temp EPDM Seals -40°F to 300°F
X50	SR	Spring Return	03, 04 (All models)	
X60	DS	Double Acting with Spring Return Cover	05, 06 (X50 - X115)	
X75			07, 08 (X50 - X115)	
X90			09, 10 (X50 - X115)	
X115				

About ASC Engineered Solutions

ASC Engineered Solutions is defined by quality—in its products, services and support. With more than 1,400 employees, the company's portfolio of precision-engineered piping support, valves and connections provides products to more than 4,000 customers across industries, such as mechanical, industrial, fire protection, oil and gas, and commercial and residential construction. Its portfolio of leading brands includes ABZ Valve®, AFCON®, Anvil®, Anvil EPS, Anvil Services, Basic-PSA, Beck®, Catawissa, Cooplet®, FlexHead®, FPPI®, Gruvlok®, J.B. Smith, Merit®, North Alabama Pipe, Quadrant®, SCI®, Sharpe®, SlideLOK®, SPF® and SprinkFLEX®. With headquarters in Commerce, CA, and Exeter, NH, ASC also has ISO 9001:2015 certified production facilities in PA, TN, IL, TX, AL, LA, KS, and RI.



asc-es.com

Building connections that last™

FC-DS-Series-4x4-v03 20221012

