



Superior Clamping and Gripping



Product Information

Compact slide CLM

CLM

Compact slide

Precise. Modular. Compact.

Compact slide CLM

Linear module with optimized length, with pneumatic drive and pre-loaded crossed roller bearings, free from play

Field of application

For use in assembly automation; e.g. as pick & place solutions.



Advantages – Your benefits

Crossed roller guide design and solid design ensured high load bearing capacities and end position accuracy in all installation positions

Pretensioned junction rollers That means absolutely scope-free

High basic load ratings in all load directions

Standardized fixing bores and connection dimensions identical for LM series for numerous combinations with other components from the modular system

Shock absorbers and proximity switches integrated in the projecting surfaces for vibration-free movements and end position monitoring

Rod lock by means of clamping cartridge for safety in case of emergency stops

Mounting pattern on the rear side (from CLM 25) this means it can also be used as a stroke unit



Sizes
Quantity: 6



Weight
0.07 .. 5.32 kg



Driving force
30 .. 482 N



Stroke
14 .. 150 mm



Repeat accuracy
0.01 .. 0.04 mm

Functional description

The upper part of the slide linearly moves out and in. The drive is a compressed air driven piston.

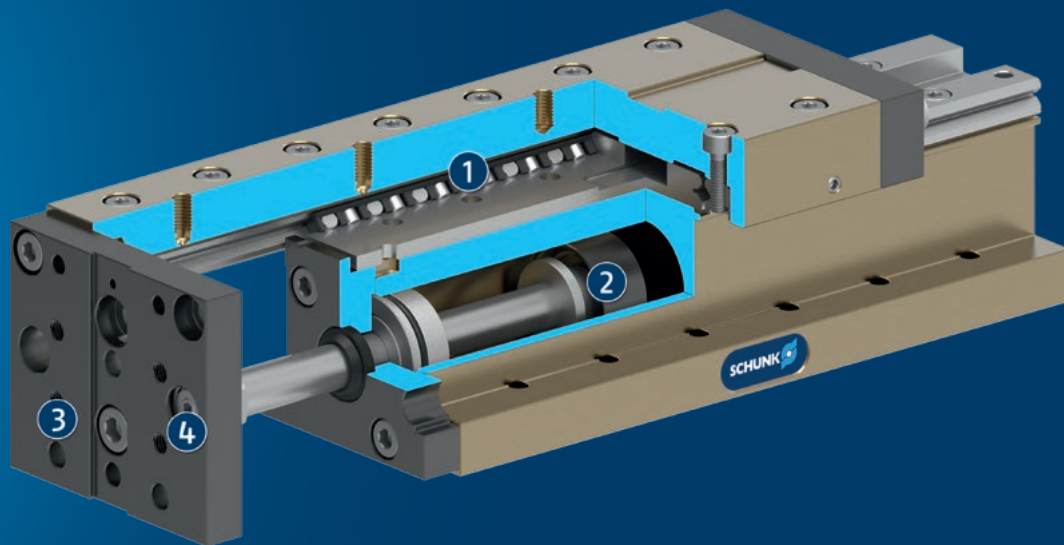

- ① **Cross roller guidance**
Pretensioned and scope-free
- ② **Drive**
Powerful piston rod cylinders
- ③ **Mounting pattern**
Completely integrated in the module system
- ④ **Damping adjustment**
Adjustment of the damping characteristics

CLM

Compact slide

General notes about the series

Housing material: Aluminum alloy, anodized

Guidance: Backlash-free, pre-loaded cross roller guide

Actuation: pneumatic, with filtered compressed air as per ISO 8573-1:2010 [7:4:4].

Scope of delivery: incl. shock absorbers respectively stop screws (CLM 08)

Warranty: 24 months

Repeat accuracy: is defined as a distribution of the end positions for 100 consecutive cycles.

Travel times: are pure movement times of the slide or the base body. Valve switching times, hose filling times, or PLC reaction times are not a part of this and are to be considered when cycle times are calculated.

Stroke: is the maximum nominal stroke of the unit. It can be shortened on both sides by the shock absorbers.

Layout or control calculation: For configuration or control calculation of the units, we recommend to use our Toolbox software, which is available online. A control calculation for the selected unit must be carried out to prevent overloading.

Ambient conditions: The modules are mainly designed for the use in clean ambient conditions. Please note that the life time of the modules can shorten if they are used in harsh ambient conditions, and that SCHUNK cannot assume liability in such cases. Please contact us for assistance.

Application example

Pneumatic pick & place unit for small components.

- ① Pillar assembly system
- ② Linear module CLM
- ③ 2-finger parallel gripper MPG-plus



SCHUNK offers more ...

The following components make the product even more productive – the suitable addition for the highest functionality, flexibility, reliability, and controlled production.



Vane swivel unit



Rotary indexing table



Gripper for small components



Universal gripper



Pressure maintenance valve

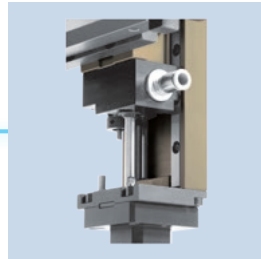

Rod lock



Pillar assembly system



Rotary gripper module



Inductive proximity switches

① For more information on these products can be found on the following product pages or at schunk.com.

Options and special information

Version rod lock: prevents the structure from falling in the event of a sudden loss of energy. This module can be combined as standard with many elements from the modular system. We can assist you with questions.

CLM 08

Compact slide

Dimensions and maximum loads

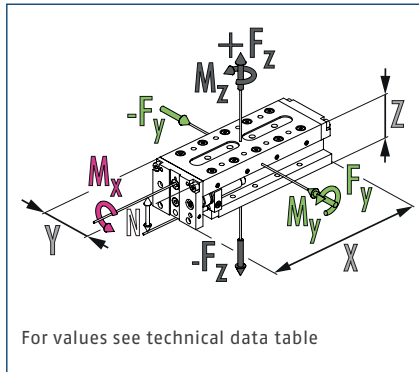

ⓘ The indicated forces and moments are maximum values for single load. If more than one force and/or torque occurs simultaneously, the case of application can be calculated by using the Toolbox. The force F_y can only be calculated by using the Toolbox.

Technical data

Description		CLM 08-H014	CLM 08-H028	CLM 08-H042
ID		0314000	0314001	0314002
Stroke	[mm]	14	28	42
extend force	[N]	30	30	30
retracted force	[N]	25	25	25
Repeat accuracy	[mm]	0.04	0.04	0.04
Piston diameter	[mm]	8	8	8
Bar diameter	[mm]	3	3	3
Min./nom./max. operating pressure	[bar]	3/6/8	3/6/8	3/6/8
Fluid consumption/10 mm stroke	[cm ³]	0.5	0.5	0.5
Overall length	[mm]	61.5	78.5	95.5
IP protection class		40	40	40
Min./max. ambient temperature	[°C]	5/60	5/60	5/60
Weight	[kg]	0.07	0.086	0.103
Drive concept		Piston rod cylinders	Piston rod cylinders	Piston rod cylinders
Dimensions X x Y x Z	[mm]	61.5 x 22 x 19	78.5 x 22 x 19	95.5 x 22 x 19
Clearance N (for moment load)	[mm]	12.3	12.3	12.3
Moments Mx max./My max./Mz max.	[Nm]	1.59/2.09/1.05	1.73/2.3/1.15	1.87/2.51/1.26
Forces Fz max.	[N]	119	93	79

Main view CLM 08-H014

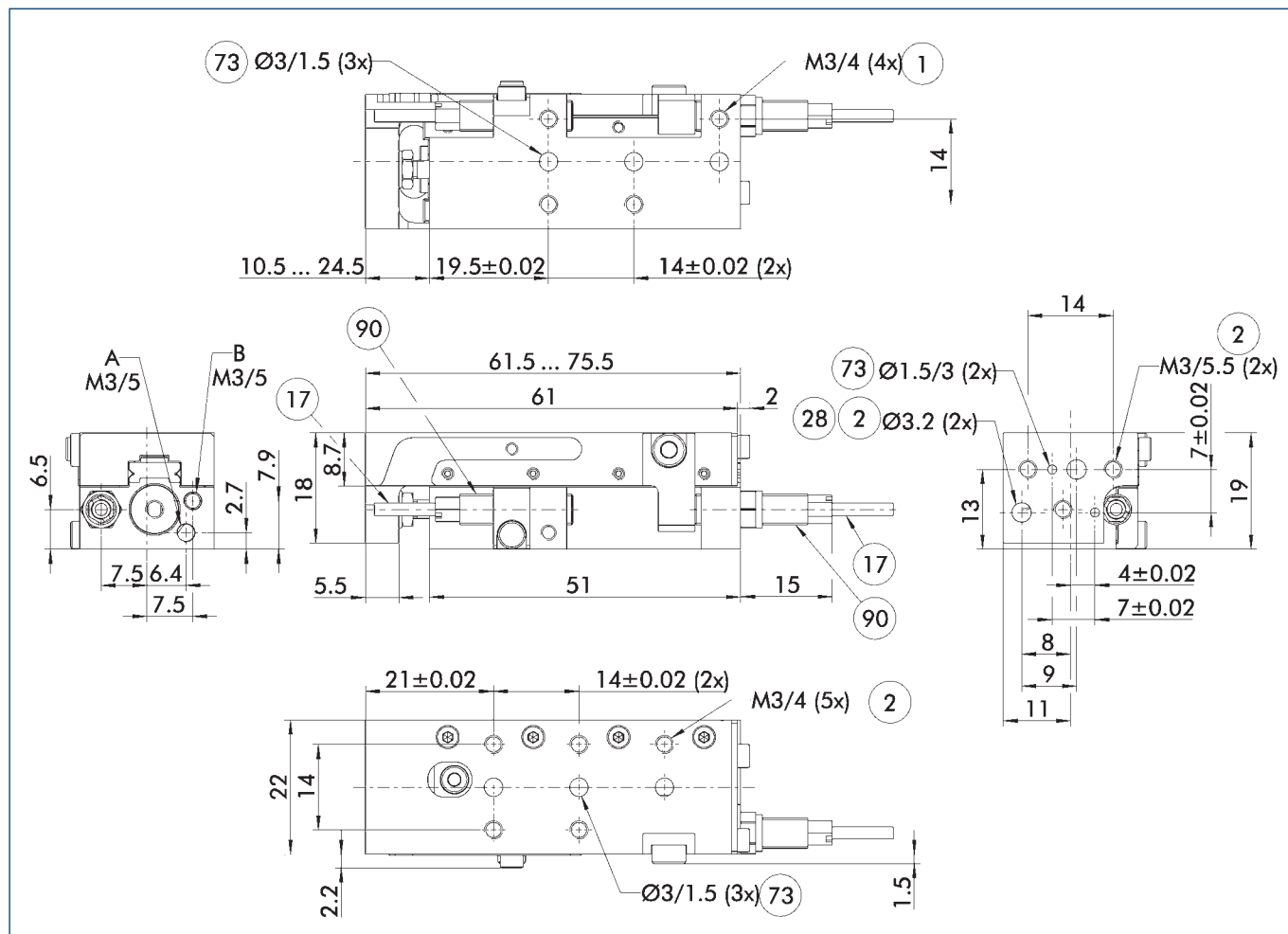

The linear module can be fastened either to the base body or the slide. The structure can also optionally be fastened to either the slide or the base body. This view shows the mounting of the module to the base body and the mounting of the structure to the slide.

- A Main connection - linear unit extended
- B Main connection - linear unit retracted
- 1 Connection linear unit
- 2 Attachment connection
- 17 Cable outlet
- 28 Through-hole
- 73 Fit for centering pins

Variant CLM 08-H028

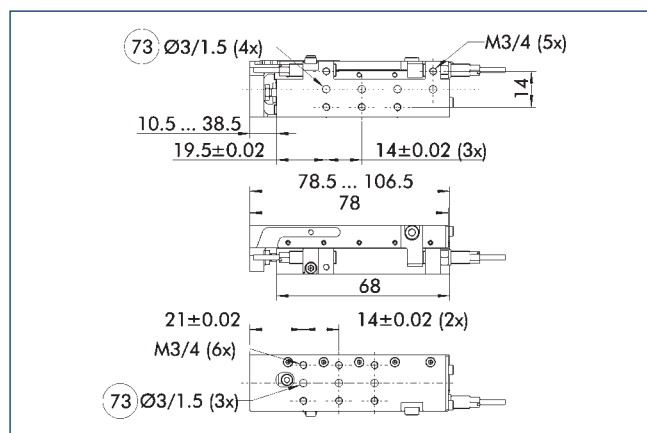

73 Fit for centering pins

Not all dimensions shown can be seen in the main view.

Variant CLM 08-H042

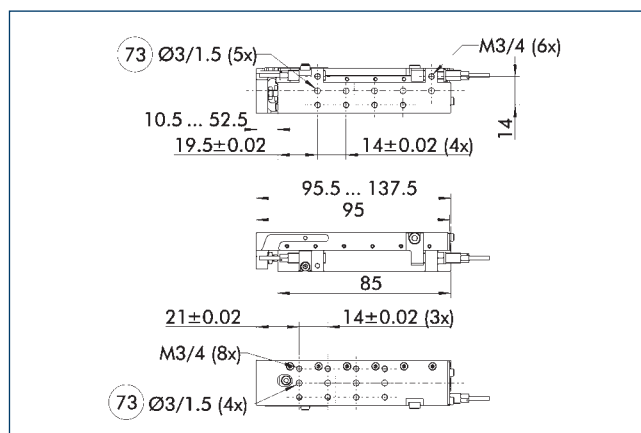

73 Fit for centering pins

Not all dimensions shown can be seen in the main view.

CLM 08

Compact slide

Fine adjustment, on the piston side

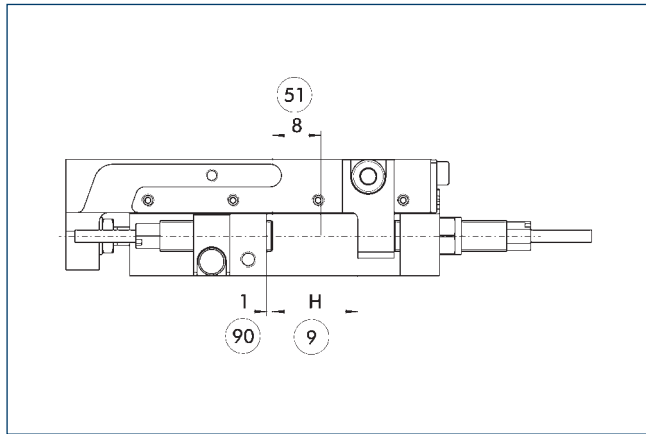

- ⑨ Nominal stroke
- ⑤① Stroke adjustment range
- ⑨⑩ This dimension may not drop below this minimum value.

To operate the unit, stops or stop sensors are needed. The illustration shows the use of the stop sensors and the possibility of stroke fine adjustment. The stops are part of the scope of delivery. The stop sensors have to be ordered separately.

Fine adjustment, on the piston rod side

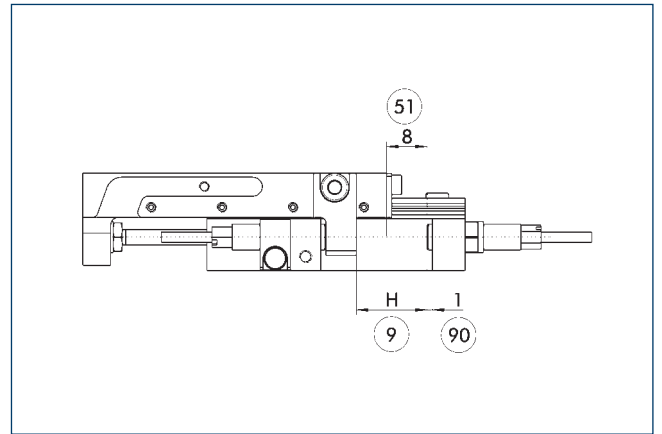

- ⑨ Nominal stroke
- ⑤① Stroke adjustment range
- ⑨⑩ This dimension may not drop below this minimum value.

To operate the unit, stops or stop sensors are needed. The illustration shows the use of the stop sensors and the possibility of stroke fine adjustment. The stops are part of the scope of delivery. The stop sensors have to be ordered separately.

Attachment to a pillar assembly system

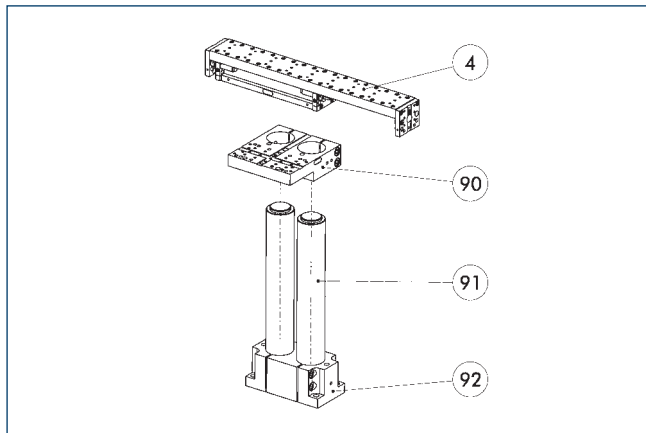

- ④ Linear unit
- ⑨⑩ Double mounting plate, APDH
- ⑨① Pillars, hard-chromium plated, ground
- ⑨② Double socket SOD

This unit can be attached to the pillar assembly system as standard. See the Kombibox software, which can be found online, for the right arrangement for your application.

Description	ID	pillar diameter [mm]	Material
Pillar assembly system mounting plate			
APDH 20	0313614	20	Aluminum
APDV 20	0313616	20	Aluminum
APEH 20	0313613	20	Aluminum
APEV 20	0313615	20	Aluminum

Modular Assembly Automation

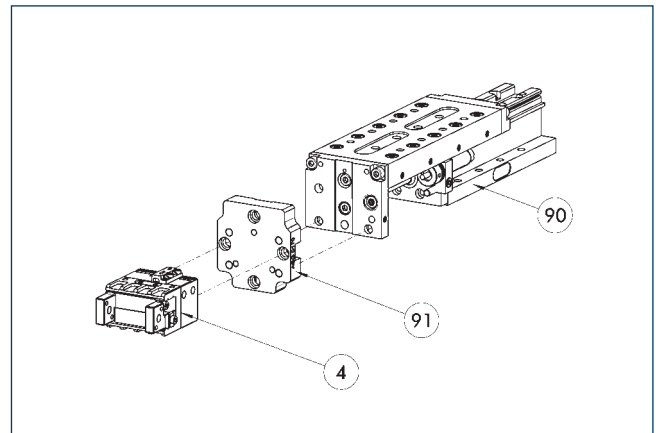

- ④ Grippers
- ⑨⑩ CLM/KLM/LM/ELP/ELM/ELS/HLM linear modules
- ⑨① ASG adapter plate

Grippers and linear modules can be combined with standard adapter plates from the modular assembly system. For more information see our main catalog "Modular Assembly Automation".

Inductive Proximity Switches

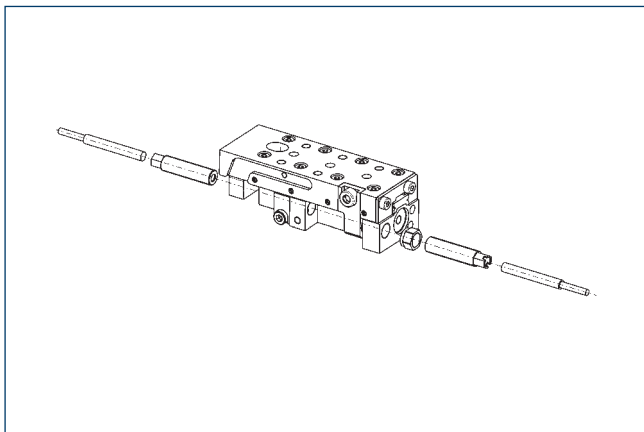

Directly mounted end position monitoring.

Description	ID	Often combined
Inductive proximity switches		
NIA 50-KT	1353751	
Connection cables		
KA BG08-L 3P-0300-PNP	0301622	●
KA BW08-L 3P-0300-PNP	0301594	
KA BW08-L 3P-0500-PNP	0301502	
Cable extension		
KV BW08-SG08 3P-0030-PNP	0301495	
KV BW08-SG08 3P-0100-PNP	0301496	
KV BW08-SG08 3P-0200-PNP	0301497	●

- ① Two sensors are required per unit for monitoring two positions. On option, extension cables and sensor distributors are available. Additional product variants of the sensor, and further information and technical data can be found in the catalog chapter sensor system.

Dimensions and maximum loads

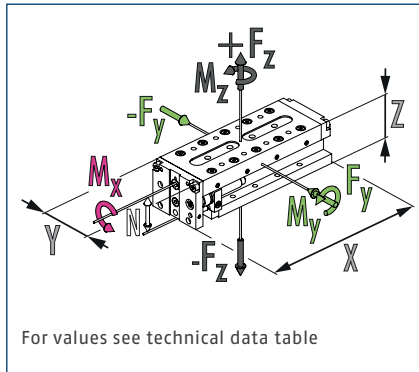

ⓘ The indicated forces and moments are maximum values for single load. If more than one force and/or torque occurs simultaneously, the case of application can be calculated by using the Toolbox. The force F_y can only be calculated by using the Toolbox.

Technical data

Description		CLM 10-H020	CLM 10-H034	CLM 10-H048
ID		0314005	0314006	0314007
Stroke	[mm]	20	34	48
extend force	[N]	47	47	47
retracted force	[N]	39	39	39
Repeat accuracy	[mm]	0.01	0.01	0.01
Piston diameter	[mm]	10	10	10
Bar diameter	[mm]	4	4	4
Min./nom./max. operating pressure	[bar]	3/6/8	3/6/8	3/6/8
Fluid consumption/10 mm stroke	[cm ³]	0.78	0.78	0.78
Overall length	[mm]	75	95	115
IP protection class		40	40	40
Min./max. ambient temperature	[°C]	5/60	5/60	5/60
Weight	[kg]	0.135	0.165	0.195
Drive concept		Piston rod cylinders	Piston rod cylinders	Piston rod cylinders
Dimensions X x Y x Z	[mm]	75 x 30 x 25	95 x 30 x 25	115 x 30 x 25
Clearance N (for moment load)	[mm]	17.1	17.1	17.1
Moments Mx max./My max./Mz max.	[Nm]	1.82/2.09/1.05	2.18/2.51/1.25	2.54/2.93/1.47
Forces Fz max.	[N]	111	91	89

Main view CLM 10-H020

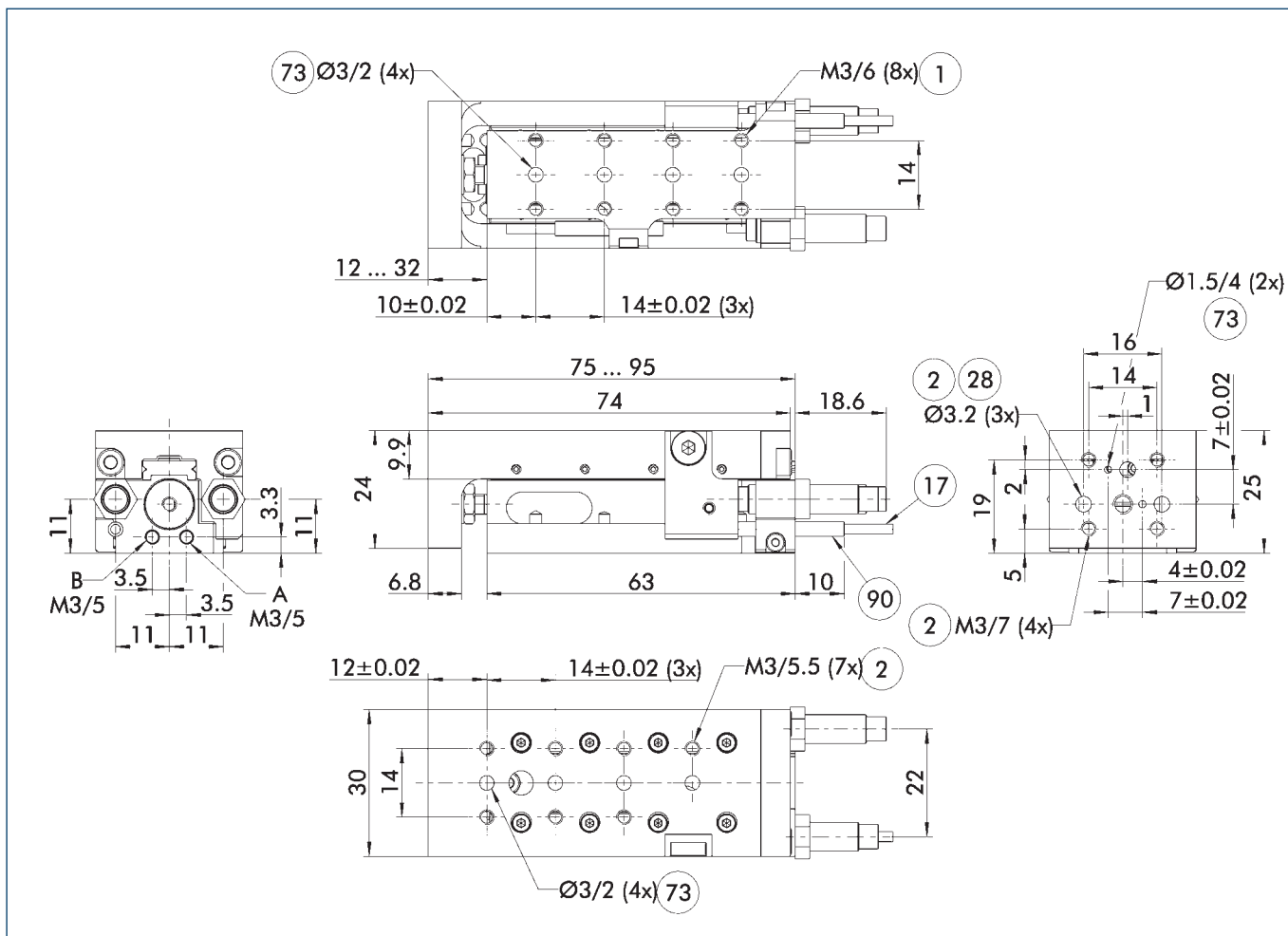

The linear module can be fastened either to the base body or the slide. The structure can also optionally be fastened to either the slide or the base body. This view shows the mounting of the module to the base body and the mounting of the structure to the slide.

- A Main connection - linear unit extended
- B Main connection - linear unit retracted
- 1 Connection linear unit
- 2 Attachment connection
- 17 Cable outlet
- 28 Through-hole
- 73 Fit for centering pins
- 90 Inductive proximity switches

Variant CLM 10-H034

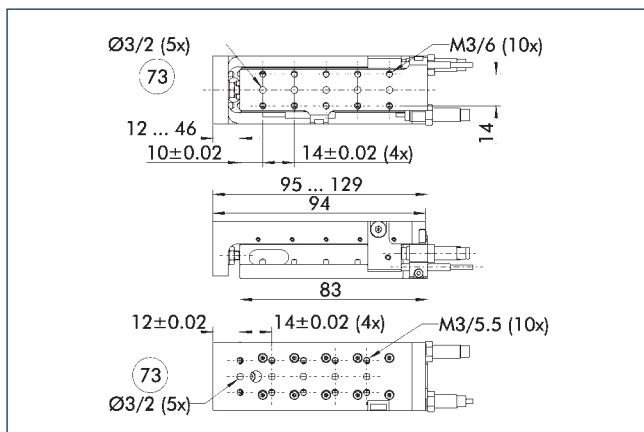

73 Fit for centering pins

Not all dimensions shown can be seen in the main view.

Variant CLM 10-H048

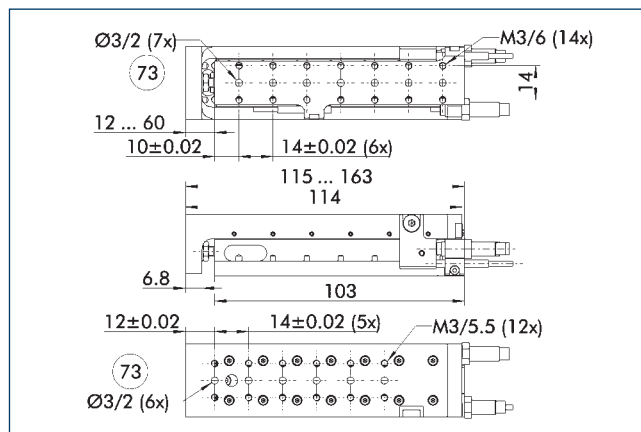

73 Fit for centering pins

Not all dimensions shown can be seen in the main view.

CLM 10

Compact slide

Fine adjustment, on the piston side

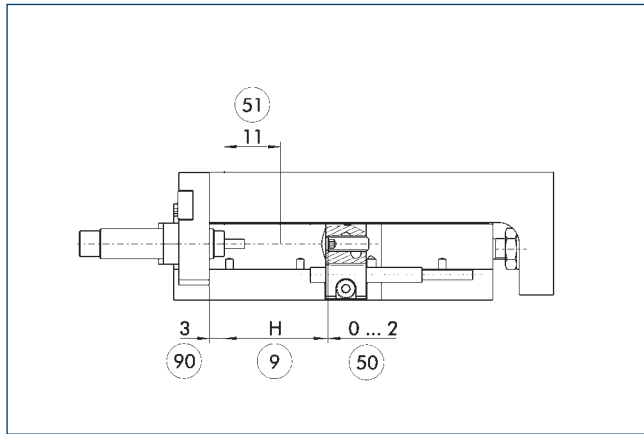

- ⑨ Nominal stroke
- ⑤① Stroke adjustment range
- ⑤② Damping stroke adjustment
- ⑨② This dimension may not drop below this minimum value.

This illustration shows the possible fine adjustment of the extended position.

Fine adjustment, on the piston rod side

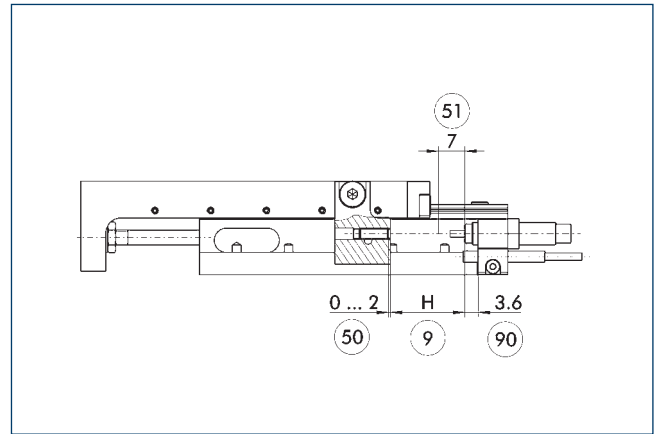

- ⑨ Nominal stroke
- ⑤① Stroke adjustment range
- ⑤② Damping stroke adjustment
- ⑨② This dimension may not drop below this minimum value.

This illustration shows the possible fine adjustment of the retracted position.

Attachment to a pillar assembly system

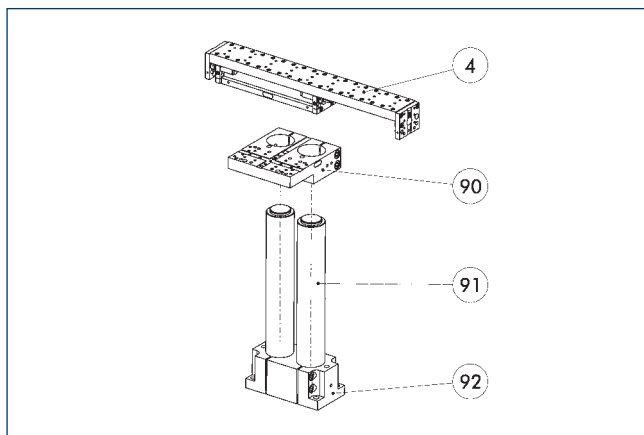

- ④ Linear unit
- ⑨② Double mounting plate, APDH
- ⑨① Pillars, hard-chromium plated, ground
- ⑨② Double socket SOD

This unit can be attached to the pillar assembly system as standard. See the Kombibox software, which can be found online, for the right arrangement for your application.

Description	ID	pillar diameter [mm]	Material
Pillar assembly system mounting plate			
APDH 20	0313614	20	Aluminum
APDV 20	0313616	20	Aluminum
APEH 20	0313613	20	Aluminum
APEV 20	0313615	20	Aluminum

Modular Assembly Automation

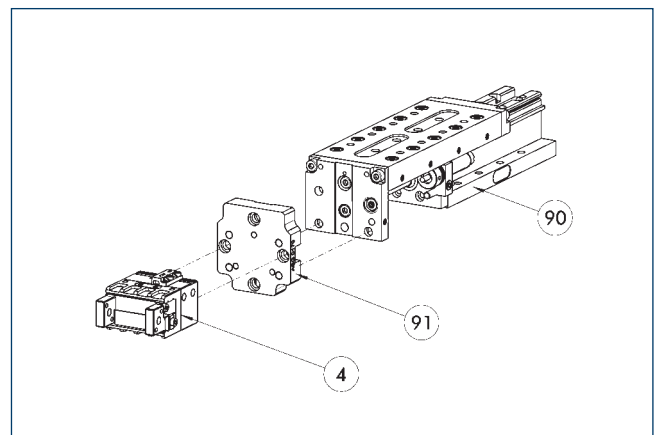

- ④ Grippers
- ⑨② CLM/KLM/LM/ELP/ELM/ELS/HLM linear modules
- ⑨① ASG adapter plate

Grippers and linear modules can be combined with standard adapter plates from the modular assembly system. For more information see our main catalog "Modular Assembly Automation".

Inductive Proximity Switches

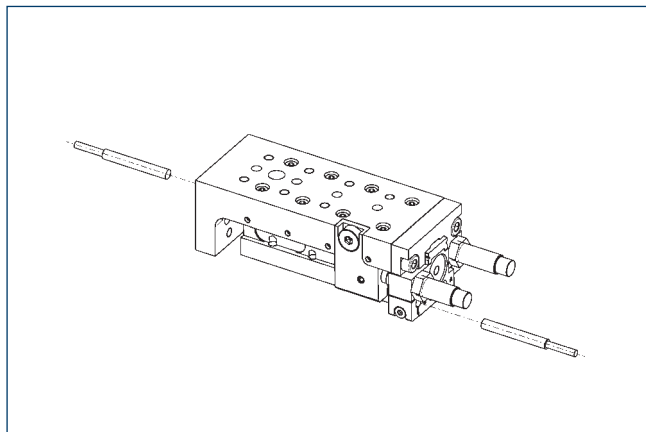

Directly mounted end position monitoring.

Description	ID	Often combined
Inductive proximity switches		
IN 30L-S-M8-PNP	1001274	
Connection cables		
KA BG08-L 3P-0300-PNP	0301622	●
KA BG08-L 3P-0500-PNP	0301623	
KA BW08-L 3P-0300-PNP	0301594	
KA BW08-L 3P-0500-PNP	0301502	
clip for plug/socket		
CLI-M8	0301463	
Cable extension		
KV BW08-SG08 3P-0030-PNP	0301495	
KV BW08-SG08 3P-0100-PNP	0301496	
KV BW08-SG08 3P-0200-PNP	0301497	●
Sensor distributor		
V2-M8	0301775	●
V4-M8	0301746	
V8-M8	0301751	

- ① Two sensors are required per unit for monitoring two positions. On option, extension cables and sensor distributors are available. Additional product variants of the sensor, and further information and technical data can be found in the catalog chapter sensor system.

Dimensions and maximum loads

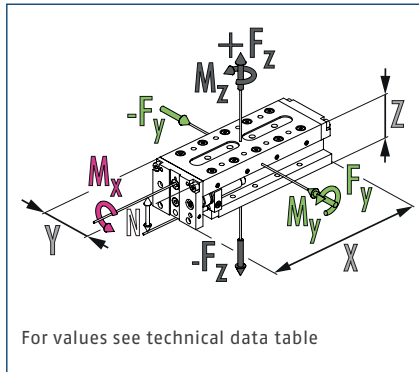

ⓘ The indicated forces and moments are maximum values for single load. If more than one force and/or torque occurs simultaneously, the case of application can be calculated by using the Toolbox. The force F_y can only be calculated by using the Toolbox.

Technical data

Description		CLM 25-H025	CLM 25-H042	CLM 25-H059
ID		0314035	0314036	0314037
Stroke	[mm]	25	42	59
extend force	[N]	67	67	67
retracted force	[N]	50	50	50
Repeat accuracy	[mm]	0.01	0.01	0.01
Piston diameter	[mm]	12	12	12
Bar diameter	[mm]	6	6	6
Min./nom./max. operating pressure	[bar]	3/6/8	3/6/8	3/6/8
Fluid consumption/10 mm stroke	[cm ³]	1.13	1.13	1.13
Overall length	[mm]	105	130	155
IP protection class		40	40	40
Min./max. ambient temperature	[°C]	5/60	5/60	5/60
Weight	[kg]	0.44	0.52	0.6
Drive concept		Piston rod cylinders	Piston rod cylinders	Piston rod cylinders
Dimensions X x Y x Z	[mm]	105 x 45 x 32	130 x 45 x 32	155 x 45 x 32
Clearance N (for moment load)	[mm]	23	23	23
Moments Mx max./My max./Mz max.	[Nm]	6.1/4.7/2.35	7.3/5.7/2.85	8.5/6.7/3.35
Forces Fz max.	[N]	179	162	152

Main view CLM 25-H025

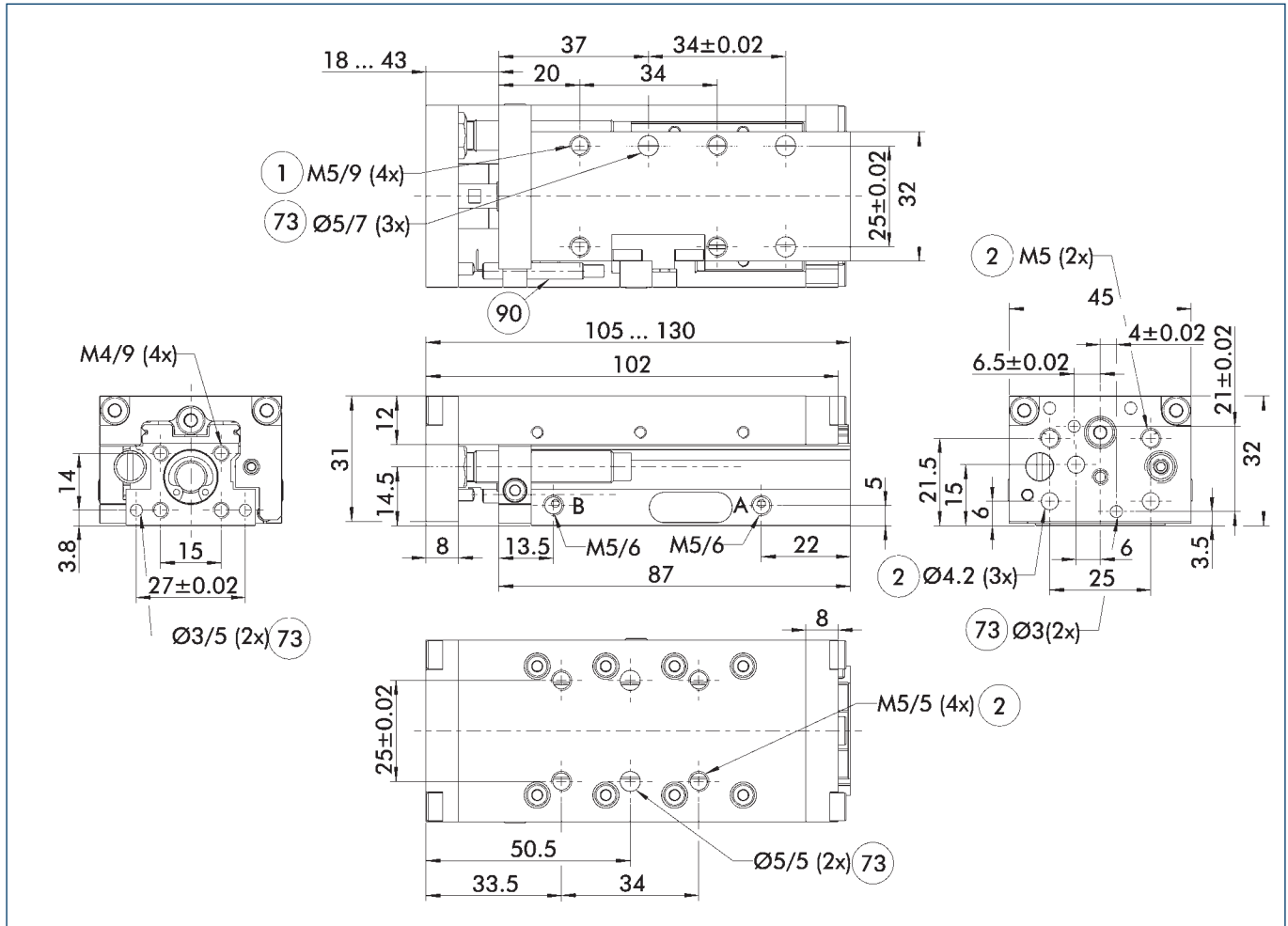

The linear module can be fastened either to the base body or the slide. The structure can also optionally be fastened to either the slide or the base body. This view shows the mounting of the module to the base body and the mounting of the structure to the slide.

- A Main connection - linear unit extended
- B Main connection - linear unit retracted
- 1 Connection linear unit
- 2 Attachment connection
- 73 Fit for centering pins
- 90 Inductive proximity switches

Variant CLM 25-H042

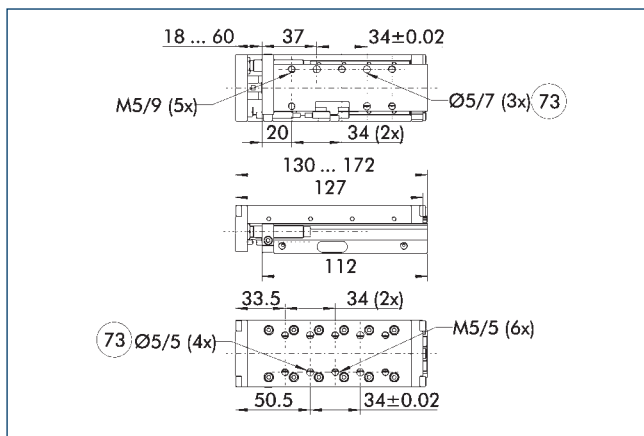

73 Fit for centering pins

Not all dimensions shown can be seen in the main view.

Variant CLM 25-H059

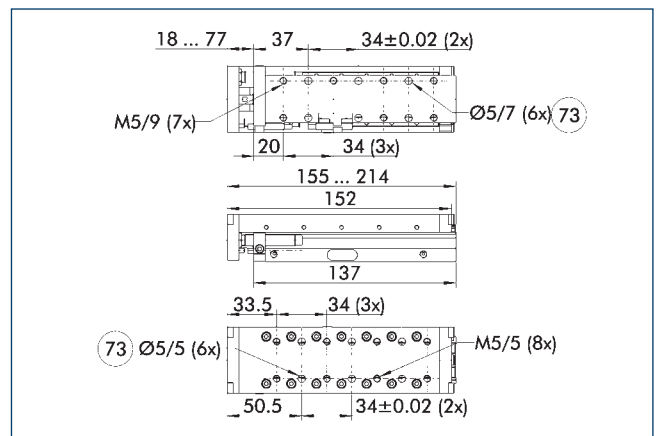

73 Fit for centering pins

Not all dimensions shown can be seen in the main view.

Fine adjustment, on the piston side

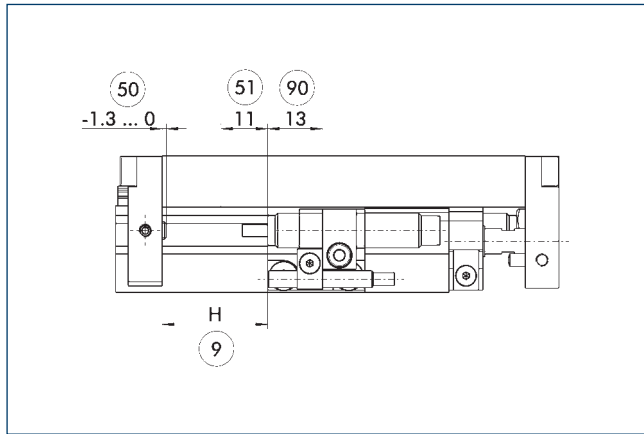

- ⑨ Nominal stroke
- ⑤① Stroke adjustment range
- ⑤① Damping stroke adjustment range
- ⑨① This dimension may not drop below this minimum value.

This illustration shows the possible fine adjustment of the extended position.

Fine adjustment, on the piston rod side

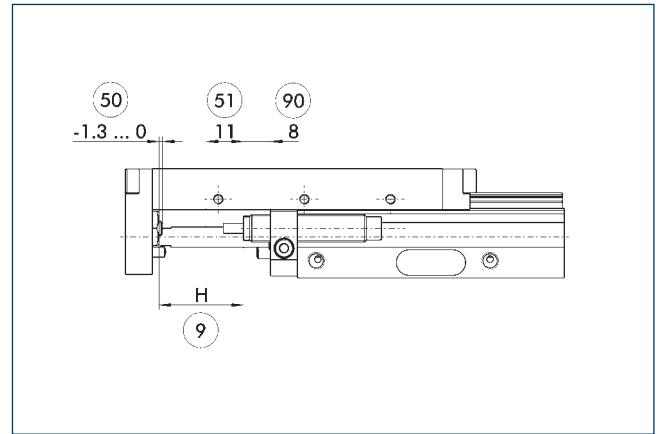

- ⑨ Nominal stroke
- ⑤① Stroke adjustment range
- ⑤① Damping stroke adjustment range
- ⑨① This dimension may not drop below this minimum value.

This illustration shows the possible fine adjustment of the retracted position.

Attachment to a pillar assembly system

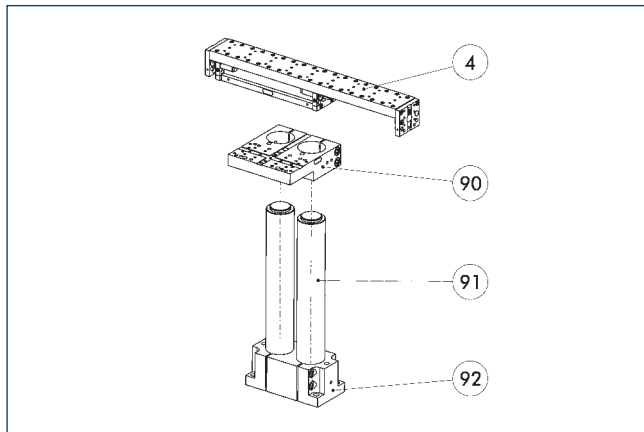

- ④ Linear unit
- ⑨① Pillars, hard-chromium plated, ground
- ⑨① Double mounting plate, APDH
- ⑨① Double socket SOD

This unit can be attached to the pillar assembly system as standard. See the Kombibox software, which can be found online, for the right arrangement for your application.

Description	ID	pillar diameter [mm]	Material
Pillar assembly system mounting plate			
APDH 20	0313614	20	Aluminum
APDH 35	0313894	35	Aluminum
APDV 20	0313616	20	Aluminum
APDV 35	0313896	35	Aluminum
APEH 20	0313613	20	Aluminum
APEH 35	0313893	35	Aluminum
APEV 20	0313615	20	Aluminum
APEV 35	0313895	35	Aluminum

Modular Assembly Automation

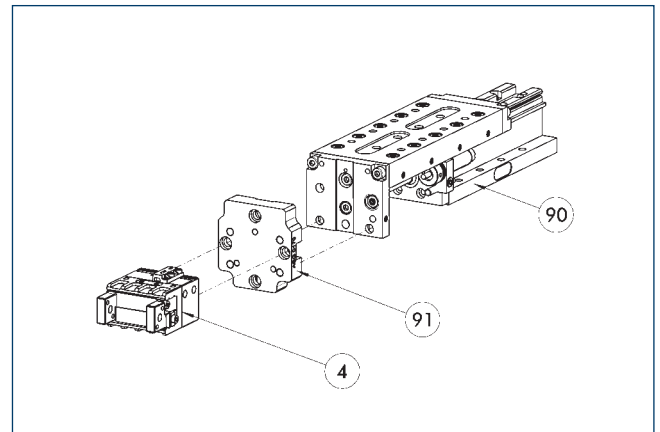

- ④ Grippers
- ⑨① ASG adapter plate
- ⑨① CLM/KLM/LM/ELP/ELM/ELS/HLM linear modules

Grippers and linear modules can be combined with standard adapter plates from the modular assembly system. For more information see our main catalog "Modular Assembly Automation".

Inductive Proximity Switches

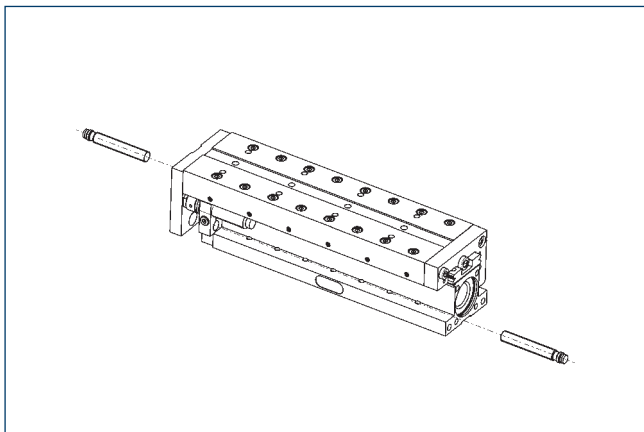

Directly mounted end position monitoring.

Description	ID	Often combined
Inductive proximity switches		
IN 40-S-M12	0301574	
IN 40-S-M8	0301474	●
INK 40-S	0301555	
Inductive proximity switch with lateral cable outlet		
IN 40-S-M12-SA	0301577	
IN 40-S-M8-SA	0301473	●
INK 40-S-SA	0301565	
Connection cables		
KA BG08-L 3P-0300-PNP	0301622	●
KA BG08-L 3P-0500-PNP	0301623	
KA BG12-L 3P-0500-PNP	30016369	
KA BW08-L 3P-0300-PNP	0301594	
KA BW08-L 3P-0500-PNP	0301502	
KA BW12-L 3P-0300-PNP	0301503	
KA BW12-L 3P-0500-PNP	0301507	
clip for plug/socket		
CLI-M12	0301464	
CLI-M8	0301463	
Cable extension		
KV BG12-SG12 3P-0030-PNP	0301999	
KV BG12-SG12 3P-0060-PNP	0301998	
KV BW08-SG08 3P-0030-PNP	0301495	
KV BW08-SG08 3P-0100-PNP	0301496	
KV BW08-SG08 3P-0200-PNP	0301497	●
KV BW12-SG12 3P-0030-PNP	0301595	
KV BW12-SG12 3P-0100-PNP	0301596	
KV BW12-SG12 3P-0200-PNP	0301597	
Sensor distributor		
V2-M12	0301776	●
V2-M8	0301775	●
V4-M8	0301746	
V8-M8	0301751	

- ① Two sensors are required per unit for monitoring two positions. On option, extension cables and sensor distributors are available. Additional product variants of the sensor, and further information and technical data can be found in the catalog chapter sensor system.

Dimensions and maximum loads

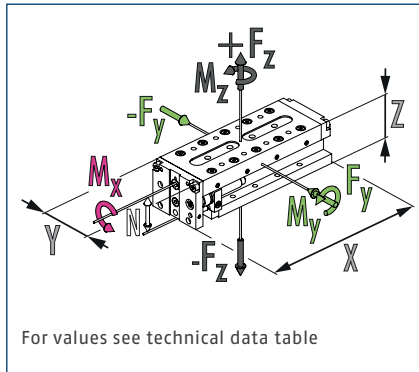

ⓘ The indicated forces and moments are maximum values for single load. If more than one force and/or torque occurs simultaneously, the case of application can be calculated by using the Toolbox. The force F_y can only be calculated by using the Toolbox.

Technical data

Description		CLM 50-H025	CLM 50-H050	CLM 50-H075	CLM 50-H100
ID		0314038	0314039	0314040	0314502
Stroke	[mm]	25	50	75	100
extend force	[N]	120	120	120	120
retracted force	[N]	103	103	103	103
Repeat accuracy	[mm]	0.02	0.02	0.02	0.02
Piston diameter	[mm]	16	16	16	16
Bar diameter	[mm]	6	6	6	6
Min./nom./max. operating pressure	[bar]	3/6/8	3/6/8	3/6/8	3/6/8
Fluid consumption/10 mm stroke	[cm ³]	2	2	2	2
Overall length	[mm]	116	156	191	231
IP protection class		40	40	40	40
Min./max. ambient temperature	[°C]	5/60	5/60	5/60	5/60
Weight	[kg]	0.76	0.98	1.16	1.36
Drive concept		Piston rod cylinders	Piston rod cylinders	Piston rod cylinders	Piston rod cylinders
Dimensions X x Y x Z	[mm]	116 x 52 x 45	156 x 52 x 45	191 x 52 x 45	231 x 52 x 45
Clearance N (for moment load)	[mm]	34	34	34	34
Moments M_x max./ M_y max./ M_z max.	[Nm]	14/11.6/5.8	17/15.1/7.55	20/18.6/9.3	23/22.1/11.05
Forces F_z max.	[N]	407	372	338	328
Options and their characteristics					
Rod lock version			CLM 50-H050-ASP	CLM 50-H075-ASP	CLM 50-H100-ASP
ID			0314439	0314440	0314505
Stroke loss of nominal stroke (on the rod side)	[mm]		10	10	10
Weight	[kg]		1.01	1.19	1.39
Static holding force	[N]		180	180	180
Max. axial play of the clamping	[mm]		0.2	0.2	0.2
Min. release pressure	[bar]		3	3	3

Main view CLM 50-H025

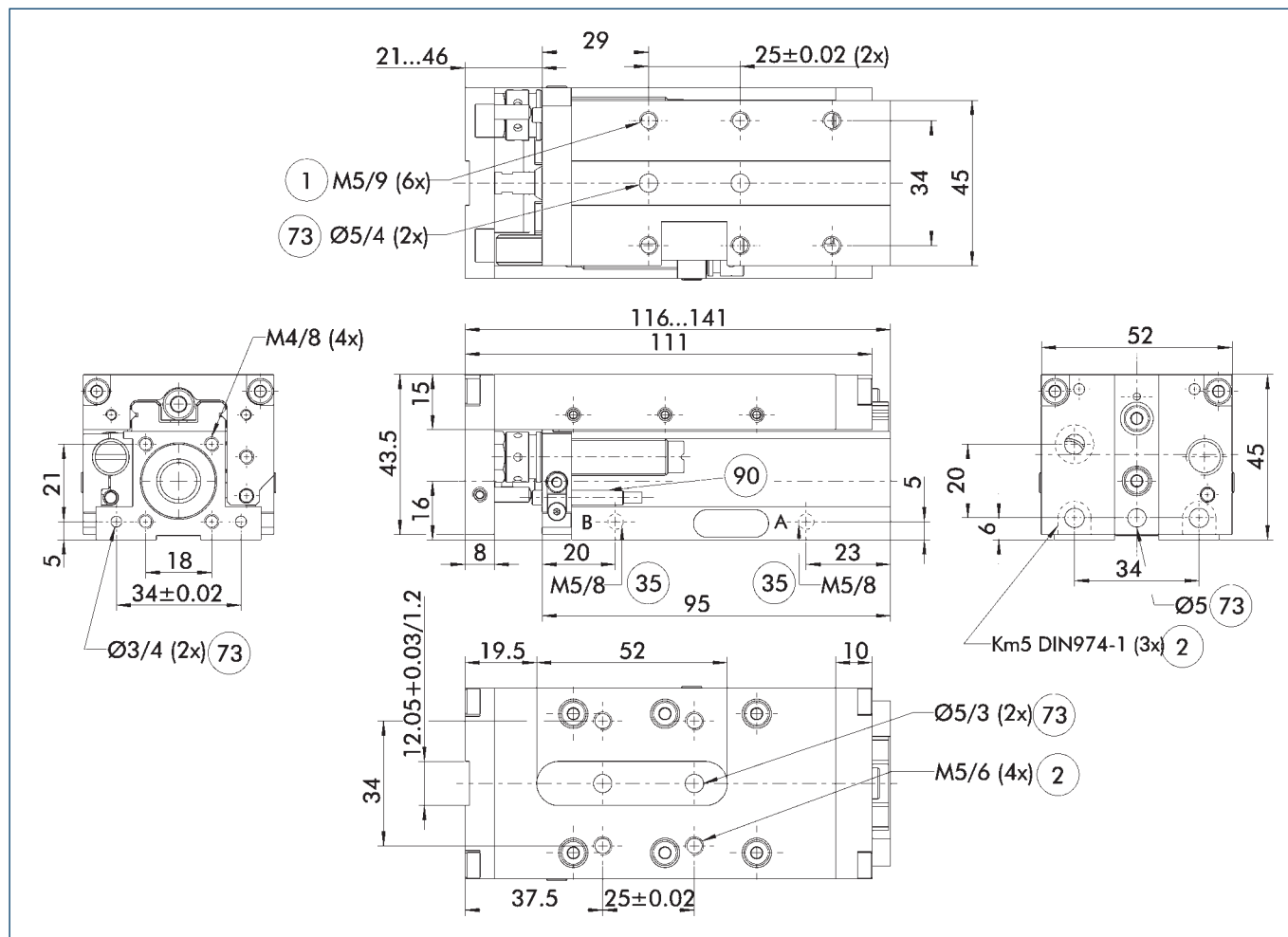

The linear module can be fastened either to the base body or the slide. The structure can also optionally be fastened to either the slide or the base body. This view shows the mounting of the module to the base body and the mounting of the structure to the slide.

- A Main connection - linear unit extended
- B Main connection - linear unit retracted
- 1 Connection linear unit
- 2 Attachment connection
- 35 Back side
- 73 Fit for centering pins
- 90 Inductive proximity switches

Variant CLM 50-H050

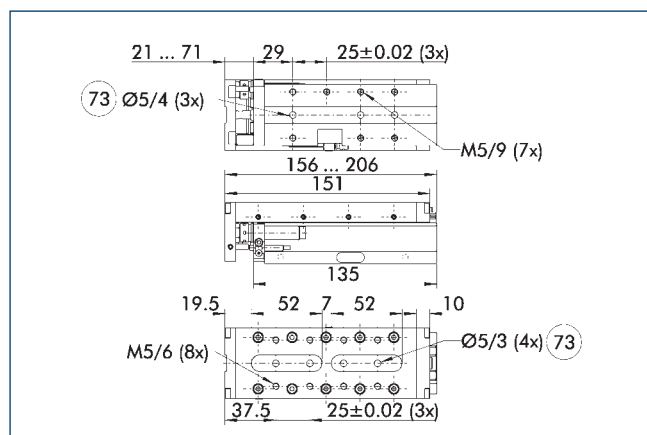

73 Fit for centering pins

Not all dimensions shown can be seen in the main view.

Variant CLM 50-H075

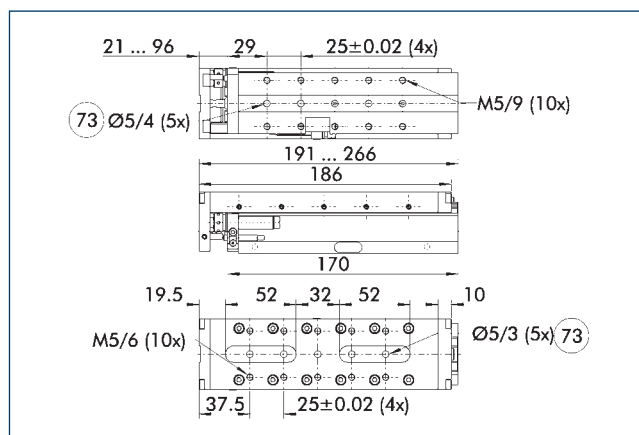

73 Fit for centering pins

Not all dimensions shown can be seen in the main view.

CLM 50

Compact slide

Variant CLM 50-H100

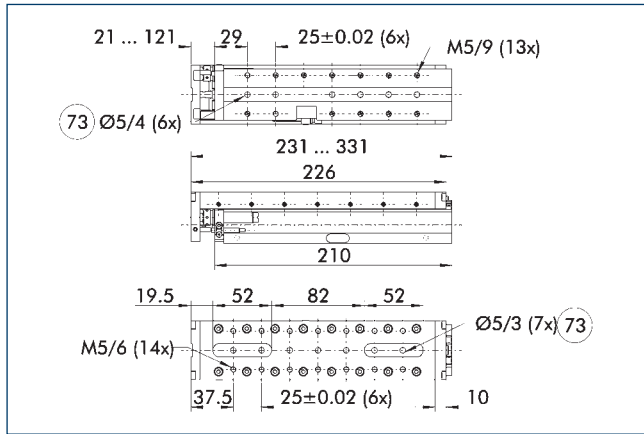

73 Fit for centering pins

Not all dimensions shown can be seen in the main view.

Fine adjustment, on the piston side

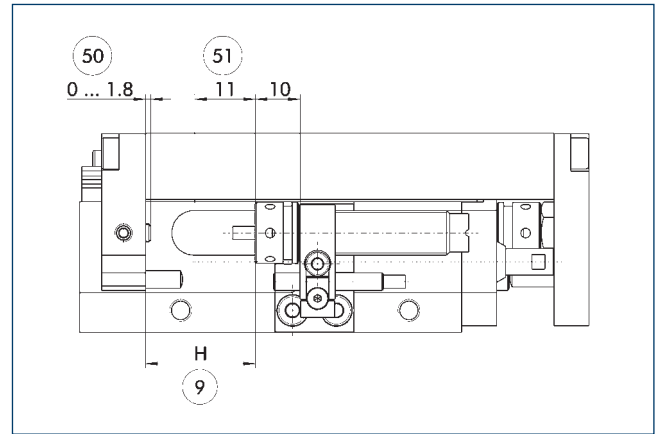

9 Nominal stroke

51 Stroke adjustment range

50 Damping stroke adjustment range

This illustration shows the possible fine adjustment of the extended position.

Fine adjustment, on the piston rod side

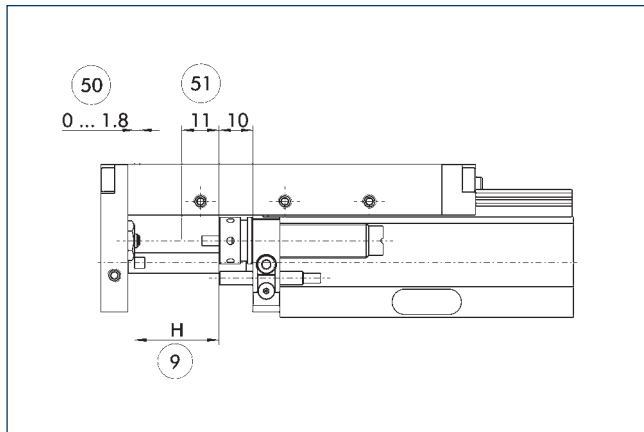

9 Nominal stroke

51 Stroke adjustment range

50 Damping stroke adjustment range

This illustration shows the possible fine adjustment of the retracted position.

Rod lock

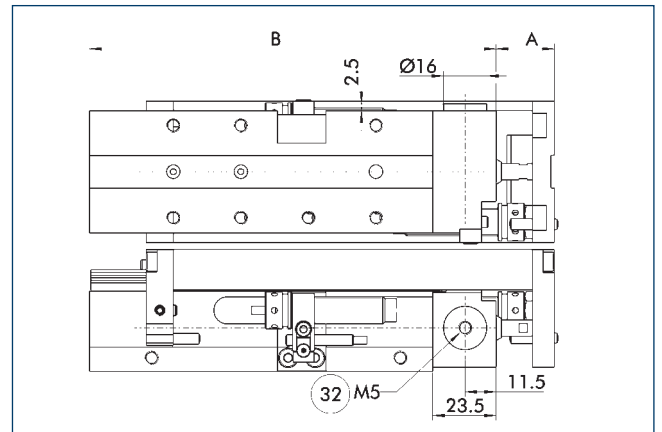

32 Pneumatic connection for holding brake

The rod lock prevents weights from falling in the event of energy loss, such as emergency stop scenarios.

Description	A [mm]	B [mm]
CLM 50-H050-ASP	15.5	150.5
CLM 50-H075-ASP	15.5	185.5
CLM 50-H100-ASP	15.5	225.5

Attachment to a pillar assembly system

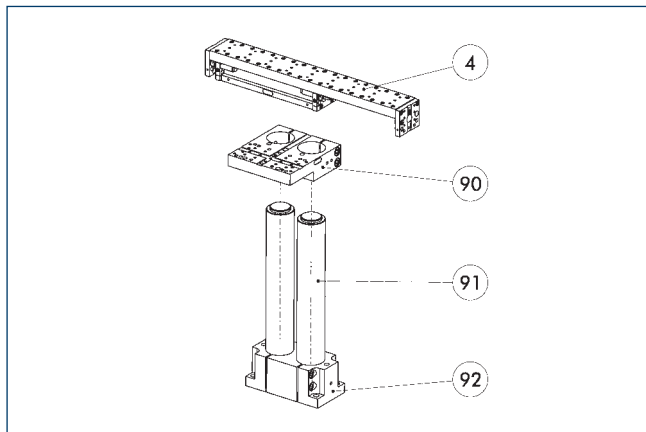

- ④ Linear unit
- ⑨① Pillars, hard-chromium plated, ground
- ⑨② Double mounting plate, APDH
- ⑨② Double socket SOD

This unit can be attached to the pillar assembly system as standard. See the Kombibox software, which can be found online, for the right arrangement for your application.

Description	ID	pillar diameter [mm]	Material
Pillar assembly system mounting plate			
APDH 35	0313894	35	Aluminum
APDH 85	0313414	55	Aluminum
APDV 35	0313896	35	Aluminum
APDV 85	0313416	55	Aluminum
APEH 35	0313893	35	Aluminum
APEH 85	0313413	55	Aluminum
APEV 35	0313895	35	Aluminum
APEV 85	0313415	55	Aluminum
Pillar assembly system media feed-through			
SPL 50	0313692		

Modular Assembly Automation

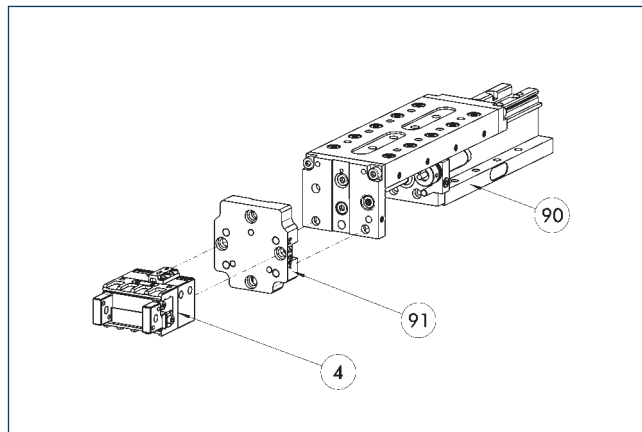

- ④ Grippers
- ⑨① ASG adapter plate
- ⑨② CLM/KLM/LM/ELP/ELM/ELS/HLM linear modules

Grippers and linear modules can be combined with standard adapter plates from the modular assembly system. For more information see our main catalog "Modular Assembly Automation".

Inductive Proximity Switches

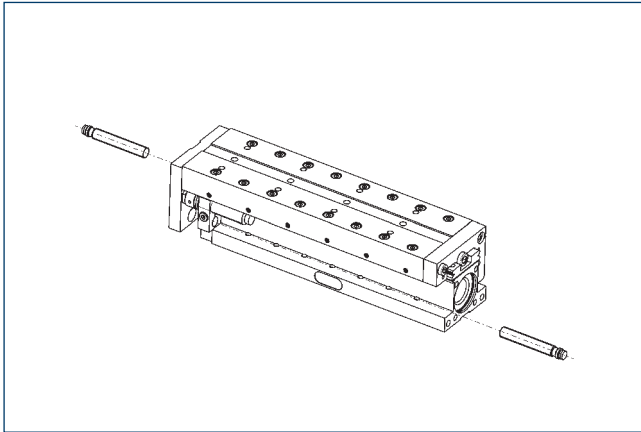

Directly mounted end position monitoring.

Description	ID	Often combined
Inductive proximity switches		
IN 40-S-M12	0301574	
IN 40-S-M8	0301474	●
INK 40-S	0301555	
Inductive proximity switch with lateral cable outlet		
IN 40-S-M12-SA	0301577	
IN 40-S-M8-SA	0301473	●
INK 40-S-SA	0301565	
Connection cables		
KA BG08-L 3P-0300-PNP	0301622	●
KA BG08-L 3P-0500-PNP	0301623	
KA BG12-L 3P-0500-PNP	30016369	
KA BW08-L 3P-0300-PNP	0301594	
KA BW08-L 3P-0500-PNP	0301502	
KA BW12-L 3P-0300-PNP	0301503	
KA BW12-L 3P-0500-PNP	0301507	
clip for plug/socket		
CLI-M12	0301464	
CLI-M8	0301463	
Cable extension		
KV BG12-SG12 3P-0030-PNP	0301999	
KV BG12-SG12 3P-0060-PNP	0301998	
KV BW08-SG08 3P-0030-PNP	0301495	
KV BW08-SG08 3P-0100-PNP	0301496	
KV BW08-SG08 3P-0200-PNP	0301497	●
KV BW12-SG12 3P-0030-PNP	0301595	
KV BW12-SG12 3P-0100-PNP	0301596	
KV BW12-SG12 3P-0200-PNP	0301597	
Sensor distributor		
V2-M12	0301776	●
V2-M8	0301775	●
V4-M8	0301746	
V8-M8	0301751	

- ① Two sensors are required per unit for monitoring two positions. On option, extension cables and sensor distributors are available. Additional product variants of the sensor, and further information and technical data can be found in the catalog chapter sensor system.

Dimensions and maximum loads

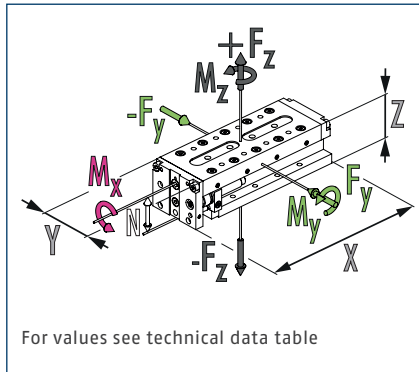

ⓘ The indicated forces and moments are maximum values for single load. If more than one force and/or torque occurs simultaneously, the case of application can be calculated by using the Toolbox. The force F_y can only be calculated by using the Toolbox.

Technical data

Description		CLM 100-H025	CLM 100-H050	CLM 100-H075	CLM 100-H100	CLM 100-H125	CLM 100-H150
ID		0314041	0314042	0314043	0314044	0314503	0314504
Stroke	[mm]	25	50	75	100	125	150
extend force	[N]	294	294	294	294	294	294
retracted force	[N]	247	247	247	247	247	247
Repeat accuracy	[mm]	0.02	0.02	0.02	0.02	0.02	0.02
Piston diameter	[mm]	25	25	25	25	25	25
Bar diameter	[mm]	10	10	10	10	10	10
Min./nom./max. operating pressure	[bar]	3/6/8	3/6/8	3/6/8	3/6/8	3/6/8	3/6/8
Fluid consumption/10 mm stroke	[cm ³]	4.9	4.9	4.9	4.9	4.9	4.9
Overall length	[mm]	129	167	204	242	317	317
IP protection class		40	40	40	40	40	40
Min./max. ambient temperature	[°C]	5/60	5/60	5/60	5/60	5/60	5/60
Weight	[kg]	1.45	1.75	2.1	2.4	3	3
Drive concept		Piston rod cylinders	Piston rod cylinders	Piston rod cylinders	Piston rod cylinders	Piston rod cylinders	Piston rod cylinders
Dimensions X x Y x Z	[mm]	129 x 65 x 60	167 x 65 x 60	204 x 65 x 60	242 x 65 x 60	317 x 65 x 60	317 x 65 x 60
Clearance N (for moment load)	[mm]	44	44	44	44	44	44
Moments M_x max./ M_y max./ M_z max.	[Nm]	30/26.4/13.2	37/33.1/16.55	44/39.7/19.85	51/46.3/23.15	58/52.9/26.45	65/59.6/29.8
Forces F_z max.	[N]	835	750	695	665	645	630
Options and their characteristics							
Rod lock version			CLM 100-H050-ASP	CLM 100-H075-ASP	CLM 100-H100-ASP	CLM 100-H125-ASP	CLM 100-H150-ASP
ID			0314442	0314443	0314444	0314506	0314507
Stroke loss of nominal stroke (on the rod side)	[mm]		12	12	12	12	12
Weight	[kg]		1.82	2.17	2.47	3.07	3.07
Static holding force	[N]		350	350	350	350	350
Max. axial play of the clamping	[mm]		0.25	0.25	0.25	0.25	0.25
Min. release pressure	[bar]		3	3	3	3	3

Main view CLM 100-H025

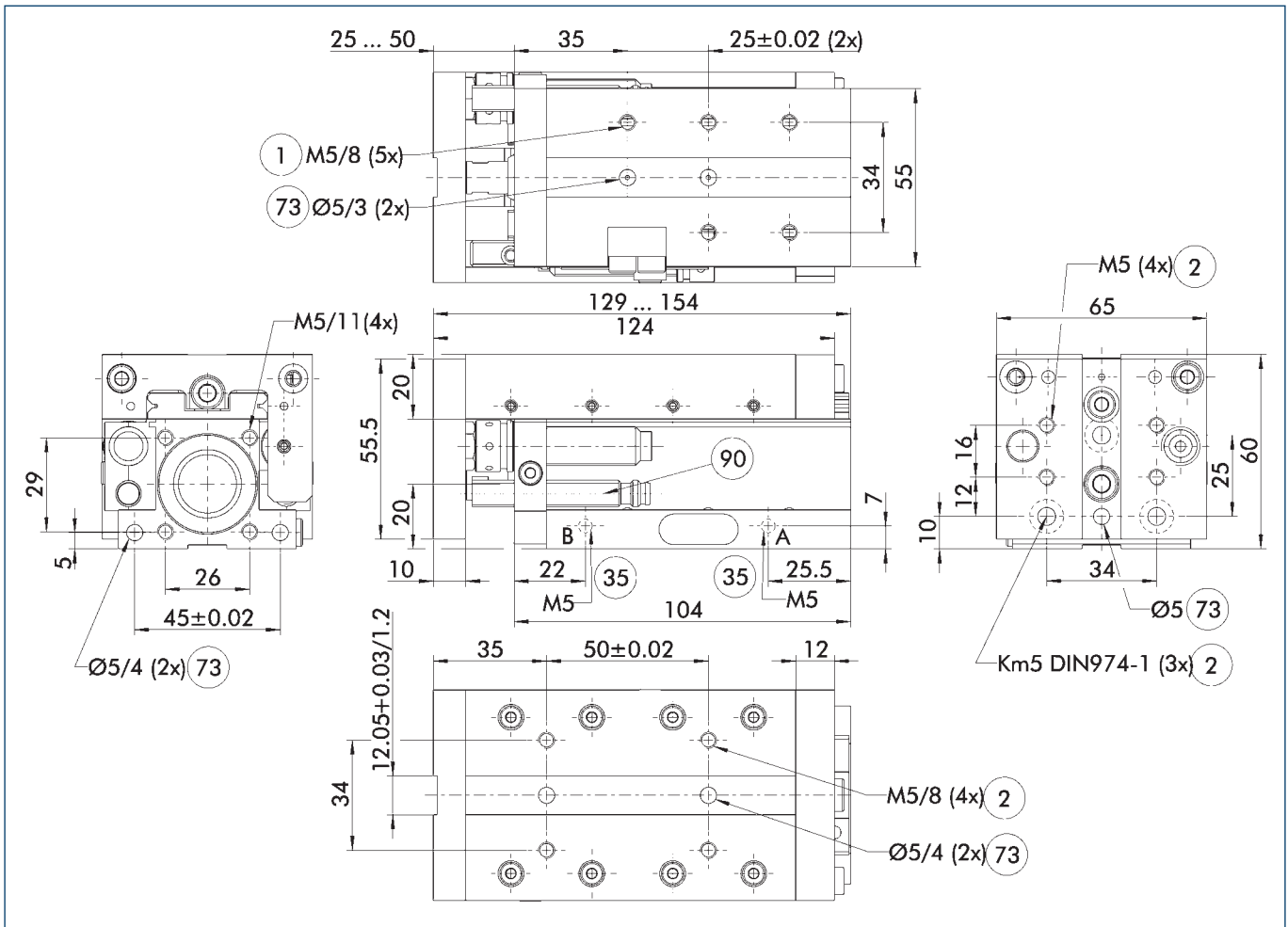

The linear module can be fastened either to the base body or the slide. The structure can also optionally be fastened to either the slide or the base body. This view shows the mounting of the module to the base body and the mounting of the structure to the slide.

- A Main connection - linear unit extended
- B Main connection - linear unit retracted
- ① Connection linear unit
- ② Attachment connection
- ③⑤ Back side
- ⑦③ Fit for centering pins
- ⑨⑩ Inductive proximity switches

Variant CLM 100-H050

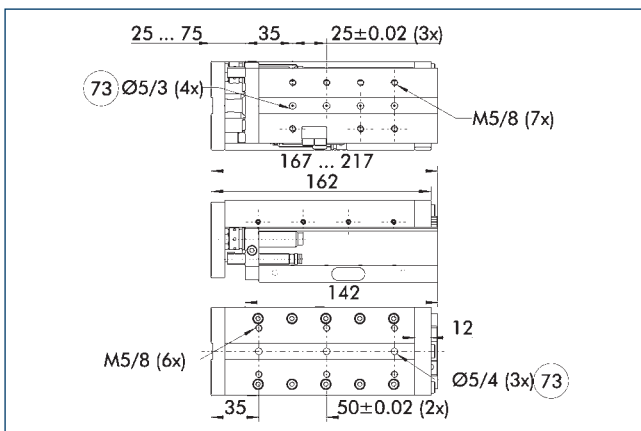

⑦③ Fit for centering pins

Not all dimensions shown can be seen in the main view.

Variant CLM 100-H075

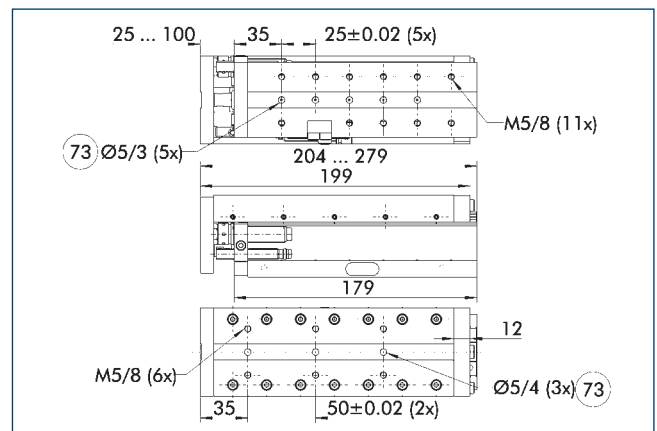

⑦③ Fit for centering pins

Not all dimensions shown can be seen in the main view.

CLM 100

Compact slide

Variant CLM 100-H100

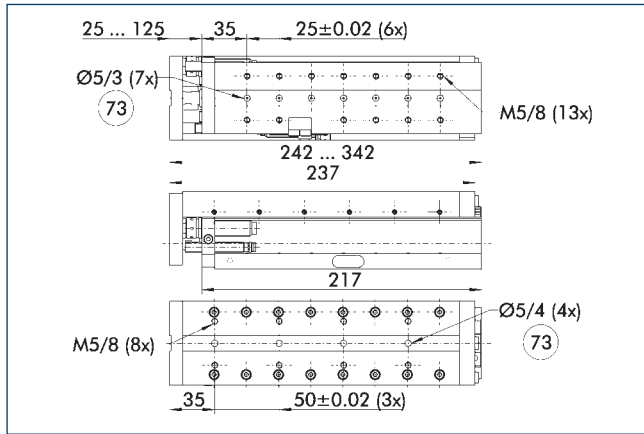

73 Fit for centering pins

Not all dimensions shown can be seen in the main view.

Variant CLM 100-H125/150

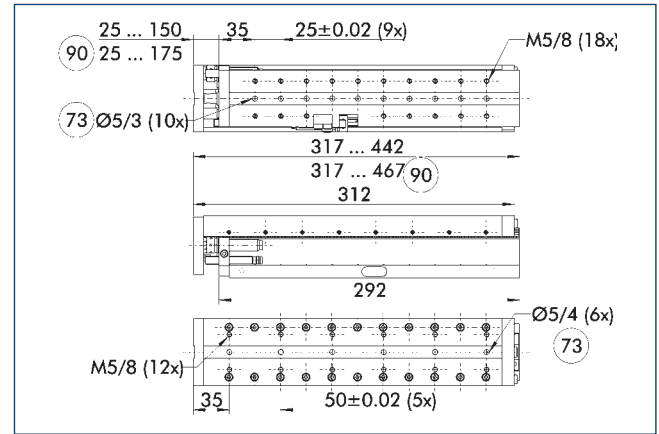

73 Fit for centering pins

90 Applicable stroke variant H150

Not all dimensions shown can be seen in the main view.

Fine adjustment, on the piston side

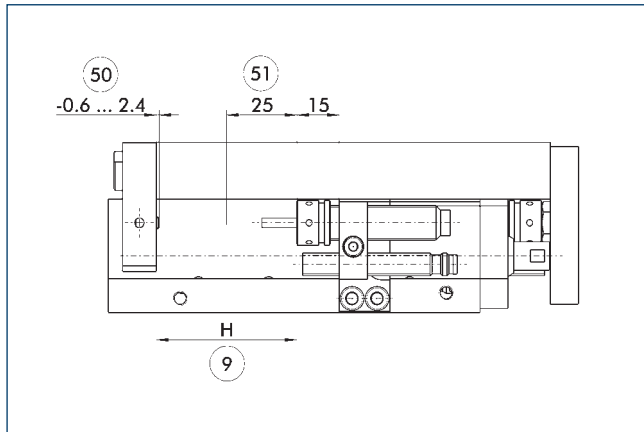

9 Nominal stroke

51 Stroke adjustment range

50 Damping stroke adjustment range

This illustration shows the possible fine adjustment of the extended position.

Fine adjustment, on the piston rod side

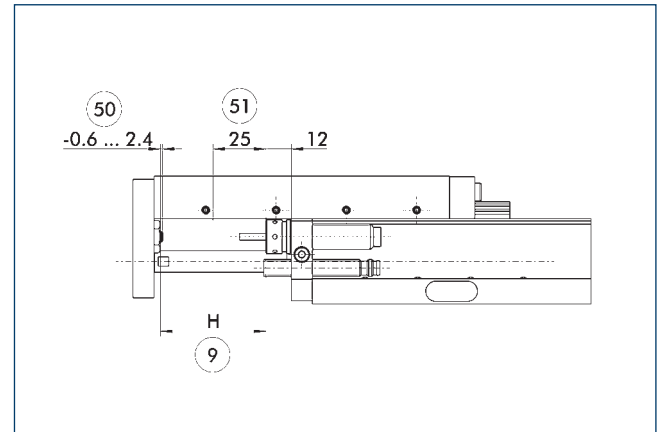

9 Nominal stroke

51 Stroke adjustment range

50 Damping stroke adjustment range

This illustration shows the possible fine adjustment of the retracted position.

Rod lock

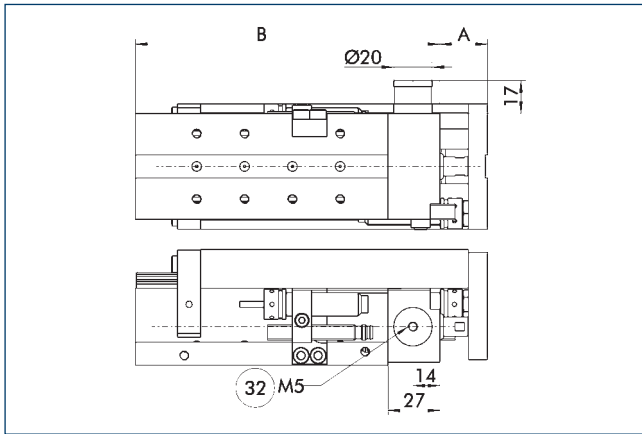

- 32 Pneumatic connection for holding brake

The rod lock prevents weights from falling in the event of energy loss, such as emergency stop scenarios.

Description	A [mm]	B [mm]
CLM 100-H050-ASP	20	159
CLM 100-H075-ASP	20	196
CLM 100-H100-ASP	20	234
CLM 100-H125-ASP	20	309
CLM 100-H150-ASP	20	309

Attachment to a pillar assembly system

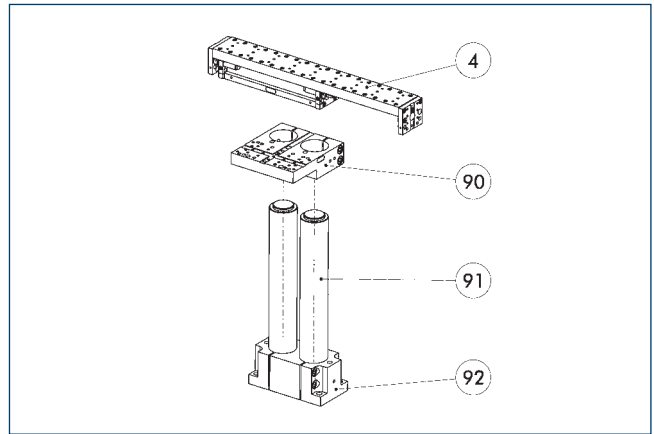

- 4 Linear unit
- 90 Double mounting plate, APDH
- 91 Pillars, hard-chromium plated, ground
- 92 Double socket SOD

This unit can be attached to the pillar assembly system as standard. See the Kombibox software, which can be found online, for the right arrangement for your application.

Description	ID	pillar diameter [mm]	Material
Pillar assembly system mounting plate			
APDH 35	0313894	35	Aluminum
APDH 85	0313414	55	Aluminum
APDV 35	0313896	35	Aluminum
APDV 85	0313416	55	Aluminum
APEH 35	0313893	35	Aluminum
APEH 85	0313413	55	Aluminum
APEV 35	0313895	35	Aluminum
APEV 85	0313415	55	Aluminum
Pillar assembly system media feed-through			
SPL 50	0313692		

Modular Assembly Automation

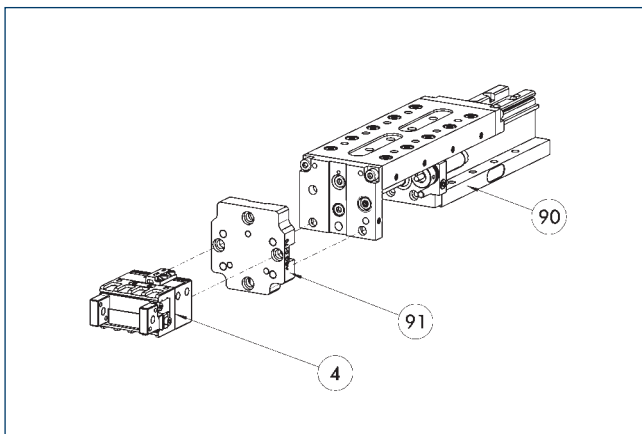

- 4 Grippers
- 90 CLM/KLM/LM/ELP/ELM/ELS/HLM linear modules
- 91 ASG adapter plate

Grippers and linear modules can be combined with standard adapter plates from the modular assembly system. For more information see our main catalog "Modular Assembly Automation".

Inductive Proximity Switches

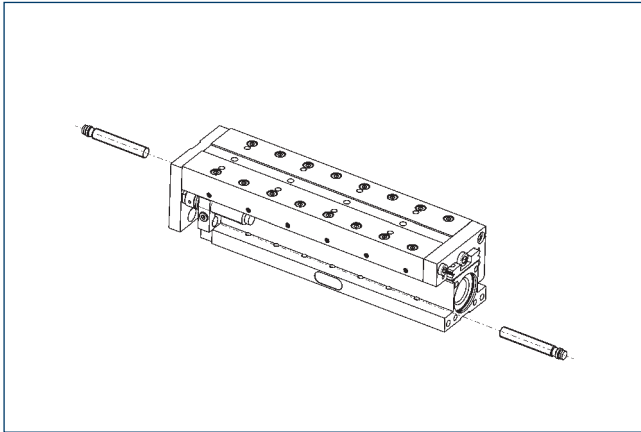

Directly mounted end position monitoring.

Description	ID	Often combined
Inductive proximity switches		
NI 30-KT	0313429	
NI 32	0313425	
Connection cables		
KA BG08-L 3P-0300-PNP	0301622	●
KA BG08-L 3P-0500-PNP	0301623	
KA BW08-L 3P-0300-PNP	0301594	
KA BW08-L 3P-0500-PNP	0301502	
clip for plug/socket		
CLI-M8	0301463	
Cable extension		
KV BW08-SG08 3P-0030-PNP	0301495	
KV BW08-SG08 3P-0100-PNP	0301496	
KV BW08-SG08 3P-0200-PNP	0301497	●

- ① Two sensors are required per unit for monitoring two positions. On option, extension cables and sensor distributors are available. Additional product variants of the sensor, and further information and technical data can be found in the catalog chapter sensor systems. The NI 30-KT is to be used for the basic module. The NI 32 is to be used for the variant with rod lock.

Dimensions and maximum loads

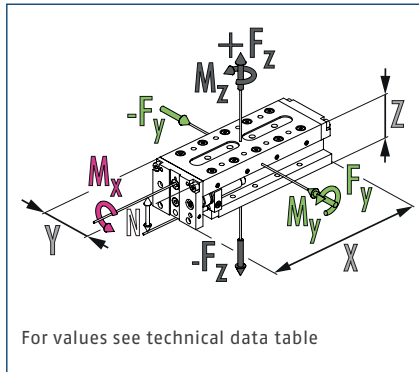

ⓘ The indicated forces and moments are maximum values for single load. If more than one force and/or torque occurs simultaneously, the case of application can be calculated by using the Toolbox. The force F_y can only be calculated by using the Toolbox.

Technical data

Description		CLM 200-H050	CLM 200-H100	CLM 200-H150
ID		0314045	0314046	0314047
Stroke	[mm]	50	100	150
extend force	[N]	482	482	482
retracted force	[N]	415	415	415
Repeat accuracy	[mm]	0.02	0.02	0.02
Piston diameter	[mm]	32	32	32
Bar diameter	[mm]	12	12	12
Min./nom./max. operating pressure	[bar]	3/6/8	3/6/8	3/6/8
Fluid consumption/10 mm stroke	[cm ³]	8.04	8.04	8.04
Overall length	[mm]	178	252	328
IP protection class		40	40	40
Min./max. ambient temperature	[°C]	5/60	5/60	5/60
Weight	[kg]	3.1	4.15	5.25
Drive concept		Piston rod cylinders	Piston rod cylinders	Piston rod cylinders
Dimensions X x Y x Z	[mm]	178 x 80 x 75	252 x 80 x 75	328 x 80 x 75
Clearance N (for moment load)	[mm]	56.5	56.5	56.5
Moments Mx max./My max./Mz max.	[Nm]	50/63/31.5	72/90/45	94/117/58.5
Forces Fz max.	[N]	1250	1185	1160
Options and their characteristics				
Rod lock version			CLM 200-H100-ASP	CLM 200-H150-ASP
ID			0314446	0314447
Stroke loss of nominal stroke (on the rod side)	[mm]		15	15
Weight	[kg]		4.22	5.32
Static holding force	[N]		600	600
Max. axial play of the clamping	[mm]		0.25	0.25
Min. release pressure	[bar]		3	3

Main view CLM 200-H050

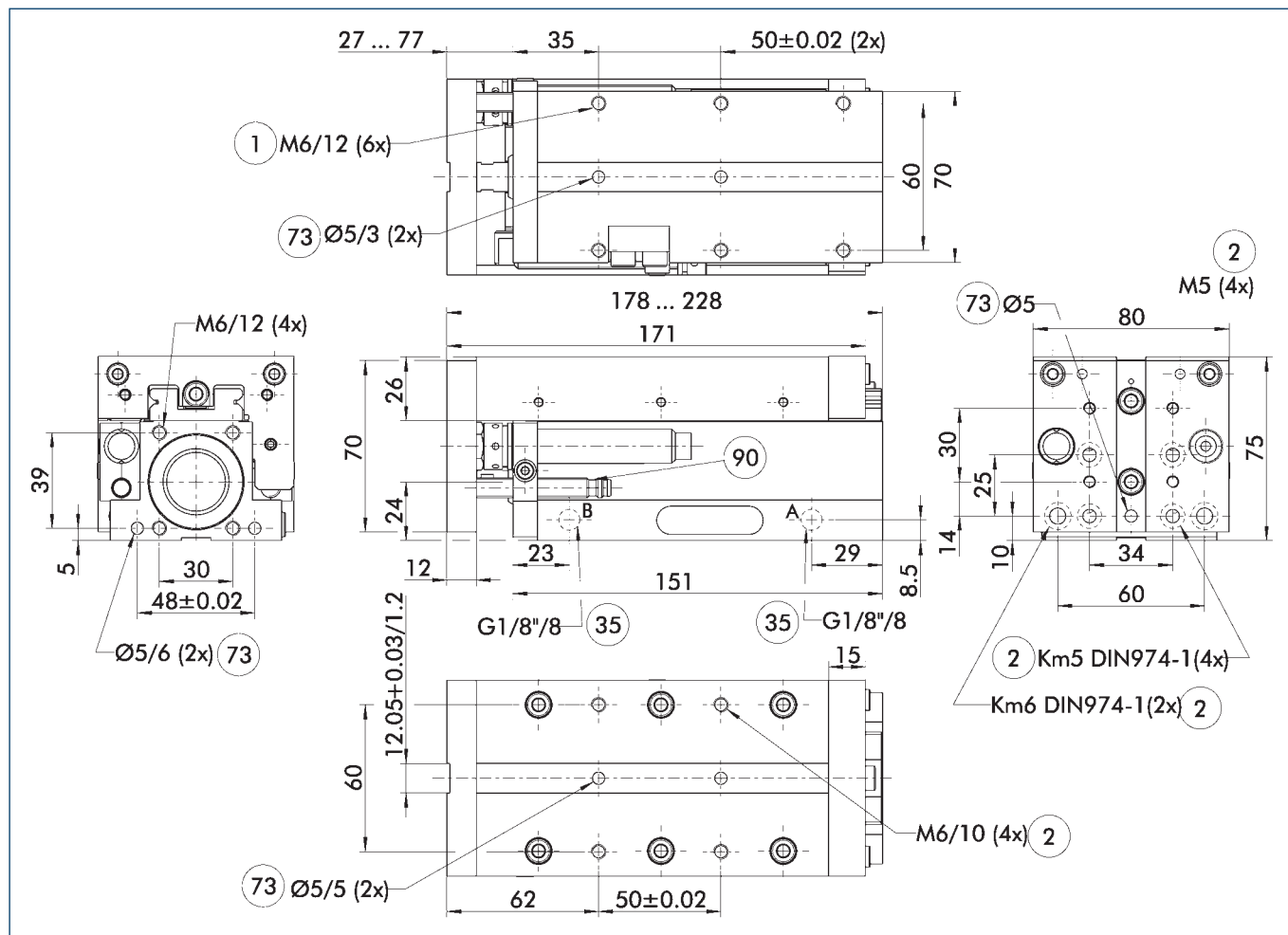

The linear module can be fastened either to the base body or the slide. The structure can also optionally be fastened to either the slide or the base body. This view shows the mounting of the module to the base body and the mounting of the structure to the slide.

- A Main connection - linear unit extended
- B Main connection - linear unit retracted
- 1 Connection linear unit
- 2 Attachment connection
- 35 Back side
- 73 Fit for centering pins
- 90 Inductive proximity switches

Variant CLM 200-H100

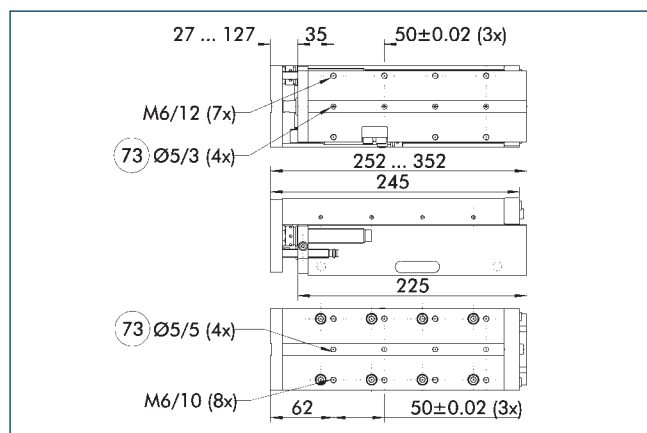

73 Fit for centering pins

Not all dimensions shown can be seen in the main view.

Variant CLM 200-H150

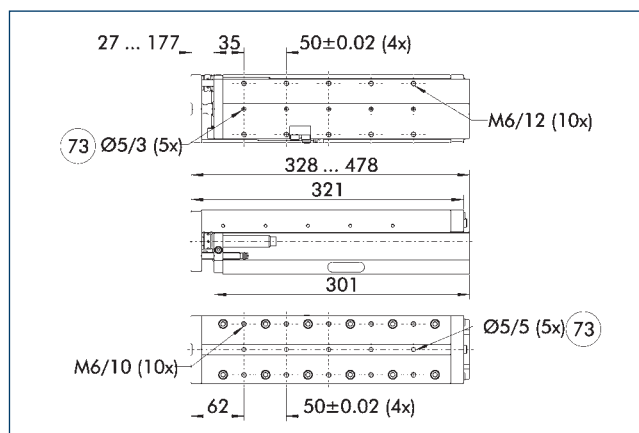

73 Fit for centering pins

Not all dimensions shown can be seen in the main view.

CLM 200

Compact slide

Fine adjustment, on the piston side

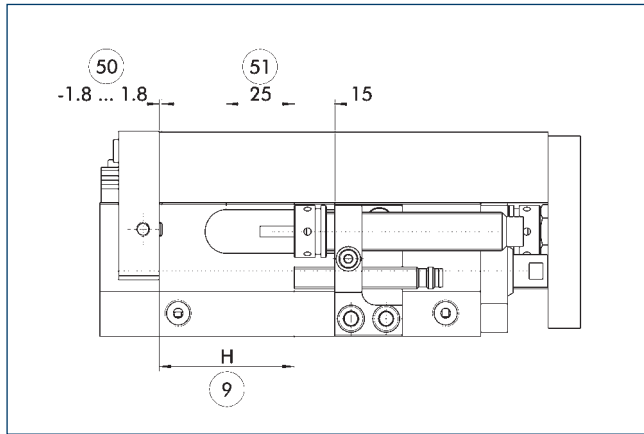

- ⑨ Nominal stroke
- ⑤① Stroke adjustment range
- ⑤① Damping stroke adjustment range

This illustration shows the possible fine adjustment of the extended position.

Fine adjustment, on the piston rod side

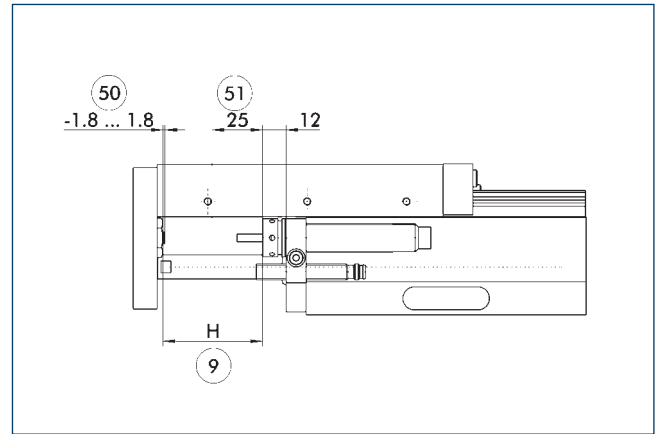

- ⑨ Nominal stroke
- ⑤① Stroke adjustment range
- ⑤① Damping stroke adjustment range

This illustration shows the possible fine adjustment of the retracted position.

Rod lock

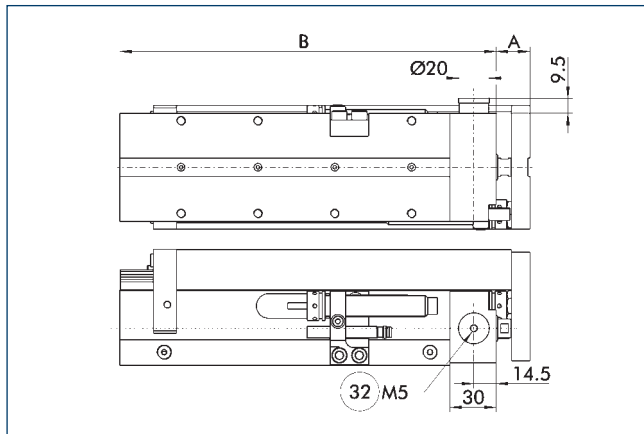

- ③② Pneumatic connection for holding brake

The rod prevents weights from falling in the event of energy loss, such as emergency stop scenarios.

Description	A [mm]	B [mm]
CLM 200-H100-ASP	22	245
CLM 200-H150-ASP	22	321

Attachment to a pillar assembly system

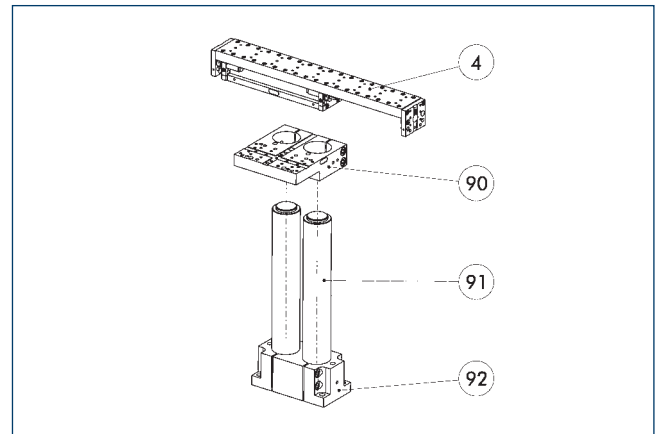

- ④ Linear unit
- ⑨① Pillars, hard-chromium plated, ground
- ⑨① Double mounting plate, APDH
- ⑨② Double socket SOD

This unit can be attached to the pillar assembly system as standard. See the Kombibox software, which can be found online, for the right arrangement for your application.

Description	ID	pillar diameter [mm]	Material
Pillar assembly system mounting plate			
APDH 85	0313414	55	Aluminum
APDV 85	0313416	55	Aluminum
APEH 85	0313413	55	Aluminum
APEV 85	0313415	55	Aluminum
Pillar assembly system media feed-through			
SPL 200	0313693		

Modular Assembly Automation

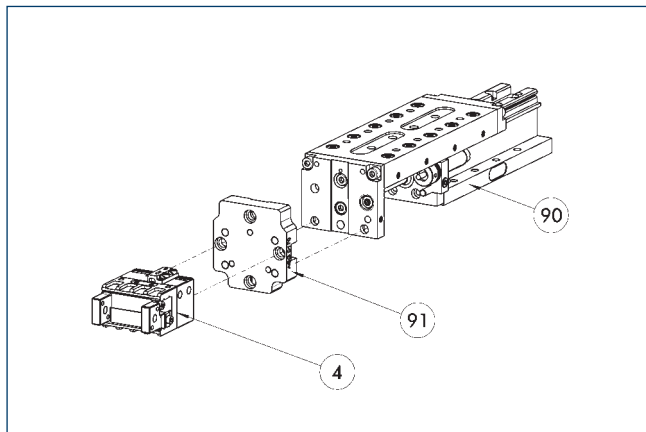

- ④ Grippers
- ⑨① ASG adapter plate
- ⑨① CLM/KLM/LM/ELP/ELM/ELS/HLM linear modules

Grippers and linear modules can be combined with standard adapter plates from the modular assembly system. For more information see our main catalog "Modular Assembly Automation".

Inductive Proximity Switches

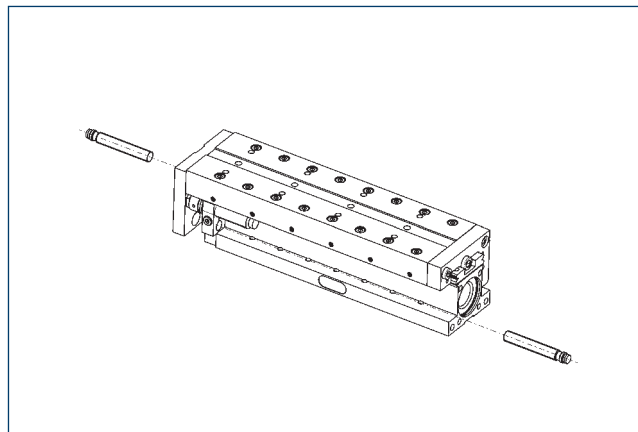

Directly mounted end position monitoring.

Description	ID	Often combined
Inductive proximity switches		
NI 30-KT	0313429	
Connection cables		
KA BG08-L 3P-0300-PNP	0301622	●
KA BG08-L 3P-0500-PNP	0301623	
KA BW08-L 3P-0300-PNP	0301594	
KA BW08-L 3P-0500-PNP	0301502	
Cable extension		
KV BW08-SG08 3P-0030-PNP	0301495	
KV BW08-SG08 3P-0100-PNP	0301496	
KV BW08-SG08 3P-0200-PNP	0301497	●

- ① Two sensors are required per unit for monitoring two positions. On option, extension cables and sensor distributors are available. Additional product variants of the sensor, and further information and technical data can be found in the catalog chapter sensor system.



SCHUNK GmbH & Co. KG
Spann- und Greiftechnik

Bahnhofstr. 106 - 134
D-74348 Lauffen/Neckar
Tel. +49-7133-103-0
Fax +49-7133-103-2399
info@de.schunk.com
schunk.com

Folgen Sie uns | *Follow us*

