

M-60X

Explosion Proof Flowswitch with In-line Flow

Key Features

- Well suitable for corrosive and non-corrosive liquids or gases
- UL recognized for hazardous location
- ATEX and IECEx certified for intrinsic safety and encapsulation and dust environments
- Community Europe compliant
- Universal Mounting available

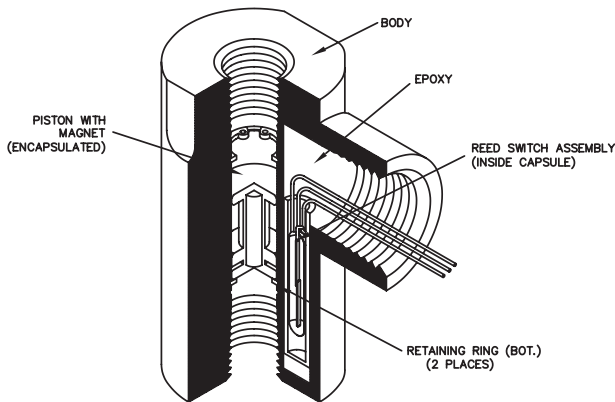

Illustrated is the M-60X model with 1/4" ports.

Custom Version Available

Malema welcomes the opportunity to apply its flow sensor experience to work for its customers. Please contact the factory for any special requirements; such as ports, extreme temperature and pressure capabilities, etc.

Description

The M-60X Explosion proof Series low flow, flow switches monitor increasing and decreasing flow. They utilize a single moving part which responds to fluid (liquid or gas) flowing within a system. These switches are suitable for a wide range of applications in industrial, biomedical and OEM products. The flow monitors operate only when fluid flows is absolutely established.

Operating Principle

The operating principle is based on a free floating magnetic piston which responds only to the motion of fluids within the line, not to static or system pressures. In the presence of fluid flow, controlled movement of the piston actuates an external hermetically sealed reed switch thus opening or closing the required signal circuit. This signal can be used to actuate audible or visual alarms as well as relays, or other controls. Piston travel is short which insures low hysteresis. Pressure drop across flowswitch varies from 0.035 to 2 psi (at maximum flowrates for air and liquid). Universal mounted units are outfitted with a spring which resets the piston. The spring is held in place using a perforated disc.

Applications

- Gas panels
- Hazardous fluid systems
- Pollution control monitors
- Gas leak monitors
- Sample flow monitoring
- Purge Flows

Material Versions

Housing	316 SS
Pistons	316 SS
Orifice Plate or disc (Only in Universal Mounting Version)	316 SS
Spring	Stainless Steel
Retaining ring	Stainless Steel

Other materials available on request.

Calibration range

Air	300 - 55,000 scc/min
Water	10 - 1,600 ml/min

For lower and higher trip points contact factory. Maximum flow through switch are higher.

Specifications

Set Point Accuracy	± 10% maximum
Hysteresis	15% - 30%
Repeatability	± 5% maximum

Port size

1/4" FNPT

Standard Specifications

Maximum Operating (psig)	3,000
Burst (psig)	5,000
Maximum Operating temperature	150°C (302°F)

See “Design Consideration/Construction” section

Electrical Specifications

Reed Switch data (Electrical Ratings)	10 Watts SPST or 3 Watts SPDT (Hermetically Sealed) UL Recognized. File E47258
Operating temperature	-40°C to 175°C
Switch voltage	200 Vdc (170 Vdc for SPDT)
Breakdown voltage	250 Vdc (200 Vdc for SPDT)
DC Resistive	10 VA (3 VA for SPDT)
AC Resistive	10 Watts (3 Watts for SPDT)
Switching current	0.5 A (0.25 A for SPDT)
Carrying current	1.2 A (0.5 A for SPDT)
Lead Wires	No 24 to 18 AWG. 18” length, Polymeric UL Recognized (Belden cable or special shielded cable is available)
Lead Wires Color	SPST: 2 blue wires SPDT: Green - Common, Yellow - Normally Closed, Orange - Normally Open

Reed Switch Ratings as Recognized by UL

SPST	120 Vac 24 Vdc 50 Vdc	0.1 A general purpose 0.25 A resistive 0.25 A resistive
SPDT	120 Vac 10 Vdc 24 Vdc	0.1 A general purpose 0.25 A resistive 0.1 A resistive

Installation and Maintenance

The standard switch has to be mounted vertically in the position shown above for normally open conditions and inverted position for normally closed conditions. When inverted, the switch set point will change by $\pm 5\%$; please use the product in the orientation it was calibrated (as indicated by reading the label). Universal units can be mounted horizontally or vertically. Please advise mounting orientation while ordering, so that the factory can calibrate in the required orientation as calibration does change slightly when changing orientation. Adequate filtration and sealing procedures should be used when mounting in flow lines. For detailed directions, please refer to our “Installation and Maintenance” sheet.

Design Considerations / Construction

The M-60X Series comprises a Body, piston, and Retaining rings. Selecting a flowswitch begins with selecting the body; this series is available in 316 Stainless Steel, Monel 400, or Hastelloy 276. The M-60X series contains one moving part (i.e. the piston) and two retaining rings that are in the fluid path. Construction of the piston is important from a design perspective. We manufacture three types of pistons (it is critical to select the correct piston for your application): 316 Stainless Steel, PTFE encapsulated, and Special All-Metal Piston.

1. The standard piston is a 316 Stainless Steel piston with epoxy to hold the magnet in place. This piston is recommended for non-aggressive fluids and inert gases. Stainless Steel retaining rings are typically used with this piston type.
2. The second piston that is available is PTFE Encapsulated. The piston is a magnet that has PTFE molded around it and then machined to the appropriate configuration. These pistons are primarily used in PTFE flow switches and also in other flow switch bodies (typically 316SS and Acrylic bodies) where customer prefer a piston that does not have epoxy in the fluid path; as well as a piston that is impervious to aggressive fluids and gases. This piston is highly recommended for medical applications. Hysteresis on these pistons does tend to be slightly higher (10 to 15%) than metal piston due to frictional effects, weight, and surface adhesion considerations. Prior to selecting this piston, fluid temperatures, and fluid compatibility with PTFE must be taken into account because certain aggressive chemicals at specific temperatures tend to swell PTFE causing the piston to change shape resulting in failure of the product. Stainless or PTFE retaining rings can be used with this piston.
3. The third piston that is available is a Special All-Metal piston with no epoxy (only available in 316SS). This piston is fabricated in a proprietary process with only one weld seam (leak tested) which presents an all 316SS surface to the fluid path. This piston is recommended for those applications where the piston could experience a lot of cycling wear. This piston has been tested to 250,000 cycles at 125 psi. Stainless Steel retaining rings are recommended for this piston type for low pressure applications and an orifice disc (See Universal Mounting Diagram) is recommended for high pressure (125 psi) applications.

Fixed Flow Setting Information

This model is a FIXED flowswitch. The flow set point is fixed at the factory and is NOT field adjustable. Proper calibration of the set point requires the following information. When purchasing a flowswitch, use the “Set Point Calibration” form or provide the following information on the purchase order.

- Calibration set point
- Increasing or decreasing flow
- Fluid type (i.e. liquid or gas)
- Density or specific gravity
- Viscosity
- System pressure and temperature
- Flow direction (i.e. upward or downward)
- Mounting orientation (i.e. horizontal or vertical)

Certifications

- UL and Canadian UL Recognized for use in USR, CNR - Class I, Groups A, B, C and D; Class II, Groups E, F and G, all divisions (applicable to M-100X, M-50X and M-60X), under UL File # E153446
- UL and Canadian UL Recognized for use in USR, CNR - Class I, Groups C and D; Class II, Groups E, F and G, all divisions – (applicable to M-200X), under UL File # E153446
- ATEX Certification for Intrinsic Safety and Encapsulation (under DEMKO 19 ATEX 2278X and DEMKO 19 ATEX 2270X) (Refer to control drawing for additional details)

- ⊕ II 1 G Ex ia IIC T6...T3 Ga
- ⊕ II 1 D Ex ia IIIC T80°C ... T150°C Da

- ⊕ II 2 G Ex mb IIC T3 Gb
- ⊕ II 2 D Ex mb IIIC T150°C Db

- IECEx Certification for Encapsulation and Intrinsic Safety (under IECEx UL 13.0067X and IECEx UL 13.0065X) (Refer to control drawing for additional details)

- ⊕ ia IIC T6...T3
- ⊕ ia III C T80...T150°C Da
- ⊕ mb IIC T3 Gb
- ⊕ mb IIIC T150°C Db (-40°C to +145°C)

Electrical Parameters
Um = 250 V and Im = 1 A

Electrical Parameters
Ui ≤ 30 V
Pi ≤ 0,7 W
Ci = 40pf
Li = 4 μH

Ambient temperature range	Temperature class for Gas	Temperature class for Dust
- 40 °C to + 60 °C	T6	T95°C
- 40 °C to + 75 °C	T5	T95°C
- 40 °C to + 117 °C	T3	T140°C
- 40°C to + 149 °C	T3	T175°C

- **CE Mark:** All EX flow switches are CE certified per ATEX Directive 2014/34/EU

5 Check <http://malema.com/certifications> for more information.

Cut Dimensional Drawings

Illustrated is the M-60X model with 1/4" ports and SPDT switch.
For Reference Only

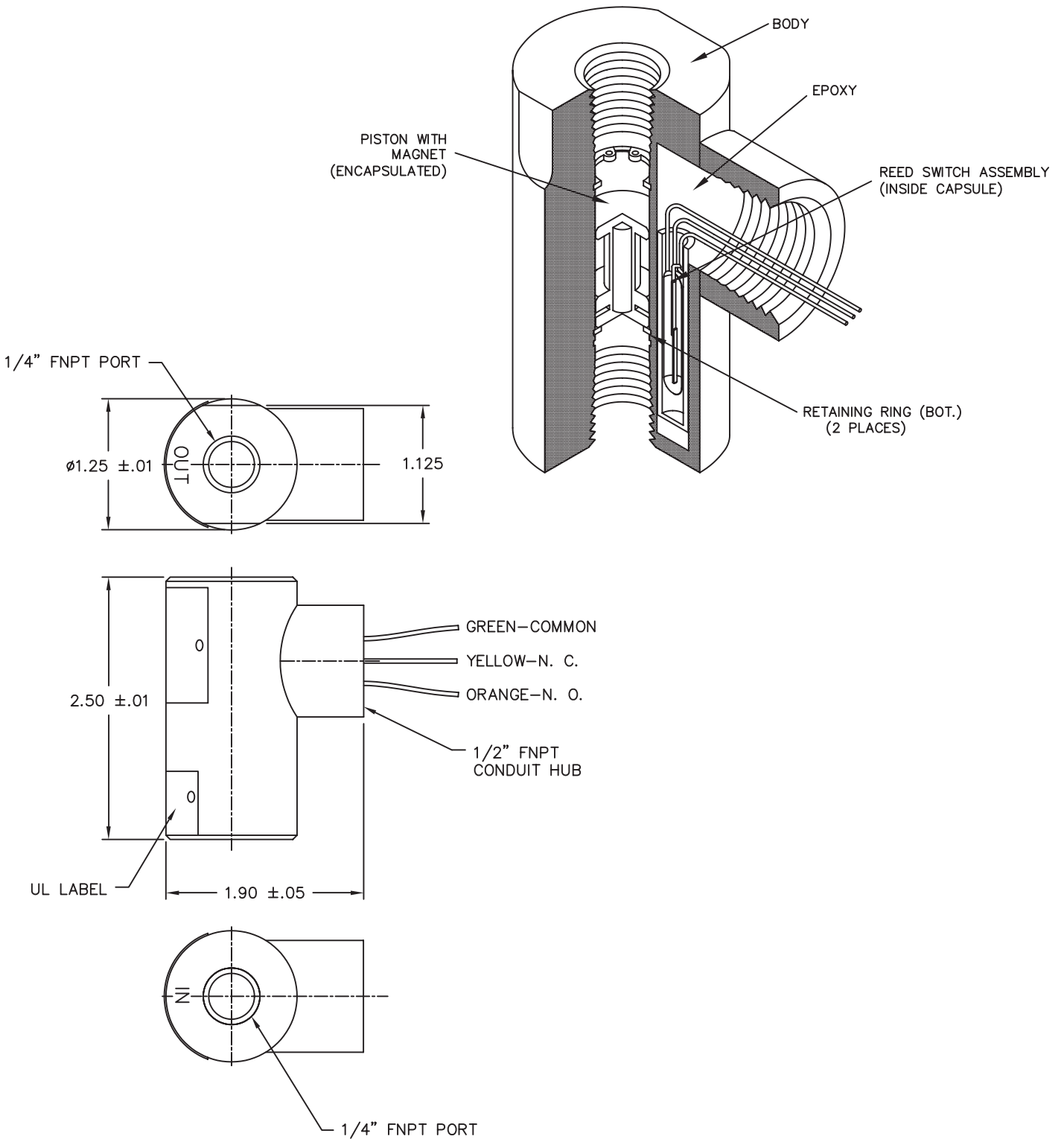

Ordering Information

Model Ordering Code										Option
M-60X	-	*	*	*	-	*	*	-	***	
	-									
Material	S									316SS
Port		2								1/4"
Switch			3							SPDT
					-					
Mounting						0				Standard (Vertical)
						1				Universal Mounting (with disc and spring)
Piston						0				316SS with epoxy
						1				PTFE encapsulated
						2				All-316SS (no epoxy)
								-	XXX	Unique PN Identifier

NOTE: Specifications are subject to change without notice.

© 2020 Malema Engineering Corporation. All rights reserved.

Malema, Malema Sensors, and Malema Engineering Corporation are service marks of Malema Engineering Corporation. All other trademarks are property of their respective owners. Malema supplies this publication for informational purposes only. While every effort has been made to ensure accuracy, this publication is not intended to make performance claims or process recommendations. Malema does not warrant, guarantee, or assume any legal liability for the accuracy, completeness, timeliness, reliability, or usefulness of any information, product, or process described herein. We reserve the right to modify or improve the designs or specifications of our products at any time without notice. For actual product information and recommendations, please contact your local Malema representative.

Corporate Headquarters

1060 S Rogers Circle
Boca Raton, FL 33487
P: (561) 995-0595 F: (561) 995-0622

West Coast Headquarters

2329 Zanker Road
San Jose, CA 95131
P: (408) 970-3419 F: (408) 970-3426

South East Asia Headquarters

35, Marsiling Industrial Estate Road 3,
02-06, Singapore 739257
P: (65) 6482-3533 F: (65) 6484-4231

India Headquarters

#1433, 3rd and 4th Floor, Pipeline Road,
Mahalakshimpuram, Bangalore 560086
P: (91) 80 2349-9362