

Data Sheet

Level Plus[®] Model LLE

Magnetostrictive Liquid Level Transmitters with Temposonics[®] Technology

- Compact Level Measurement
- Inherent Accuracy +/- 0.5 mm
- No Scheduled Maintenance or Recalibration
- Optional Integral Temperature Measurement

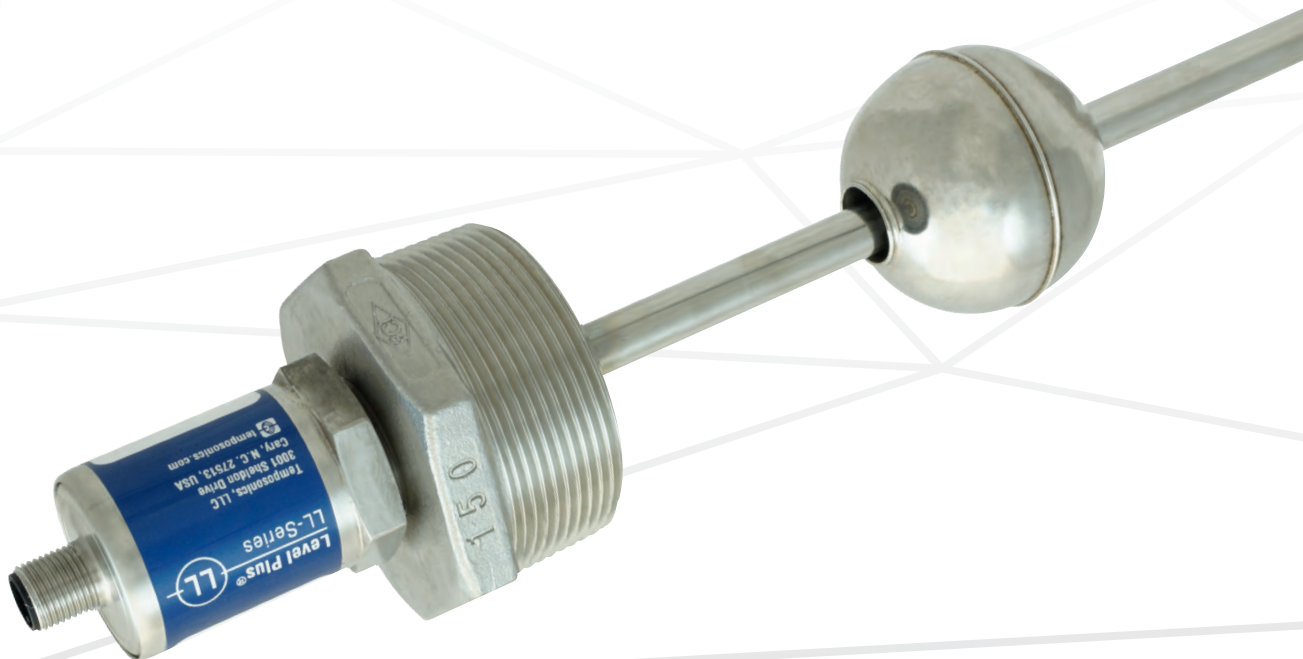

MEASURING TECHNOLOGY

The absolute, linear position sensors provided by Temposonics rely on the company's proprietary Temposonics® magnetostrictive technology, which can determine position with a high level of precision and robustness. Each Temposonics® position sensor consists of a ferromagnetic waveguide, a position magnet, a strain pulse converter and supporting electronics. The magnet, connected to the object in motion in the application, generates a magnetic field at its location on the waveguide. A short current pulse is applied to the waveguide. This creates a momentary radial magnetic field and torsional strain on the waveguide. The momentary interaction of the magnetic fields releases a torsional strain pulse that propagates the length of the waveguide. When the ultrasonic wave reaches the end of the waveguide it is converted into an electrical signal. Since the speed of the ultrasonic wave in the waveguide is precisely known, the time required to receive the return signal can be converted into a linear position measurement with both high accuracy and repeatability.

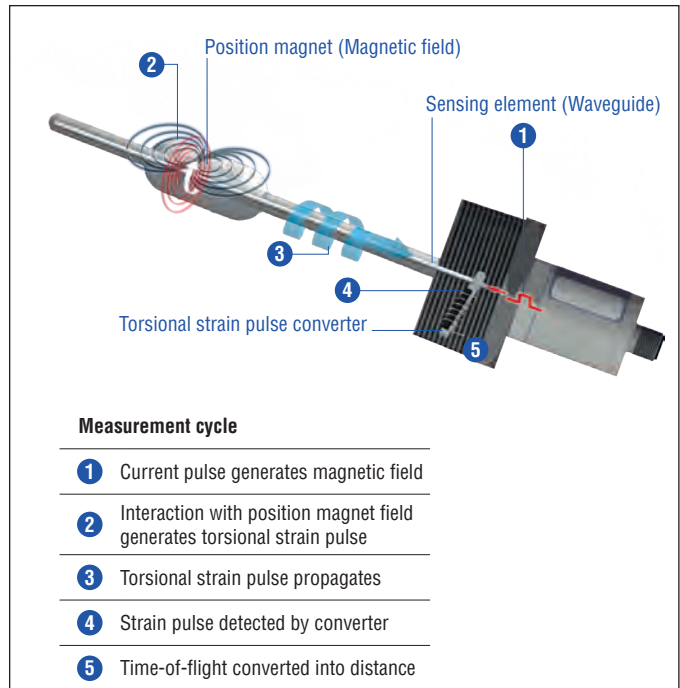

Fig. 1: Time-of-flight based magnetostrictive position sensing principle

LLE LEVEL TRANSMITTER

The Level Plus LLE satisfies the demand for an accurate and robust liquid level transmitter for general purpose applications. The LLE can provide product level and/or interface level in a compact mechanical design. The LLE can also be ordered with an optional temperature measurement of a straight RTD output. There is no requirement for scheduled maintenance or recalibration for the expected 10 year life of the sensor. Set it and Forget it.

The LLE liquid level transmitter can be mounted on most tanks offering NPT and RF flanged connections from 3/4 to 6 inches. The LLE also offers a variety of outputs including analog, CANbus, SSI and IO-Link. Included in the model number is the selection of float, cable, and stop collar options. The single model offers everything needed for level measurement in a variety of applications.

Features:

- Product and Interface Level
- No scheduled maintenance or recalibration
- Inherent Accuracy +/- 0.5 mm
- IP69K
- 100 g Shock/15 g Vibration
- Optional Integral Temperature Measurement

Applications:

- Hydraulic Reservoir
- Industrial Printers
- Firefighting Airplanes
- Waste Management
- Generators
- Process Tanks
- Skids

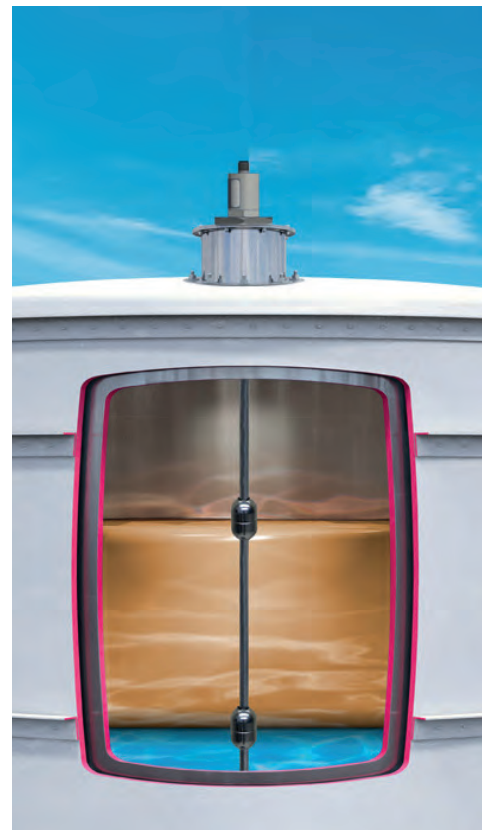

Fig. 2: Example of product and interface level measurement

TECHNICAL DATA

Level Output	
Voltage	0...10 VDC or 10...0 VDC, 0...10 VDC and 10...0 VDC (controller input resistance $R_L > 5 \text{ k}\Omega$)
Current	4...20 mA or 20...4 mA (minimum / maximum load: 0 / 500 Ω)
SSI (Synchronous Serial Interface)	Binary or Gray, 24 or 25 bit
CANbus	CANopen: CIA standard DS 301 V3.0 / encoder profile DS 406 V3.1, CAN System ISO-11898
IO-Link	V1.1, 32 bit signed, COM3 (230.4 kBaud)
Measured value	Product Level and/or Interface Level
Measurement parameters	
Resolution	0.1 mm
Inherent accuracy	$\pm 0.5 \text{ mm}$
Repeatability	$\leq \pm 0.005 \text{ \% F.S.}$ (minimum $\pm 20 \text{ }\mu\text{m}$)
Temperature Output	
Measured Variable	Single point temperature
Accuracy	Class A RTD
Output	PT100 RTD
Operating conditions	
Operating temperature	$-40...+75 \text{ }^\circ\text{C}$ ($-40...+167 \text{ }^\circ\text{F}$)
Humidity	90 % relative humidity, no condensation
Ingress protection ¹	IP67/IP69K (correctly fitted)
Shock test	100 g (single shock) IEC standard 60068-2-27
Vibration test	15 g/10...2000 Hz IEC standard 60068-2-6 (resonance frequencies excluded)
EMC test	Electromagnetic emission according to EN 61000-6-3 Electromagnetic immunity according to EN 61000-6-2 The sensor meets the requirements of the EU directives and is marked with CE
Design/Material	
Sensor electronics housing/Flange	Stainless steel 1.4305 (AISI 303); option: Stainless steel 1.4404 (AISI 316L)
Sensor rod	7 mm (0.28 in.) rod \varnothing : Stainless steel 1.4301 (AISI 304) 10 mm (0.39 in.) rod \varnothing : Stainless steel 1.4404 (AISI 316L)
Stroke length	156...2646 mm (6.2...104.2 in.)
Operating pressure	7 mm (0.28 in.) rod \varnothing : 300 bar (4351 psi), 450 bar (6527 psi) peak 10 mm (0.39 in.) rod \varnothing : 350 bar (5076 psi), 530 bar (7687 psi) peak
Mounting	
Rigid Pipe	NPT ($\frac{3}{4}$ ", 1", 1.5", 2", 2.5", 3", 4"), ANSI RF Flange (2", 3", 4", 5", 6") (150#, 300#, 600#)

Electrical connection See next page

¹/ The IP rating is not part of the UL recognition

Electrical connection	
Connection type	Analog: M12 male connector (5 pin) SSI: M12 male connector (8 pin) IO-Link: M12 male connector (4 pin) CAN: M12 male connector (5 pin)
Operating voltage	+24 VDC (-15 / +20 %); UL recognition requires an approved power supply with energy limitation (UL 61010-1), or Class 2 rating according to the National Electrical Code (USA) / Canadian Electrical Code
Ripple	$\leq 0.28 V_{pp}$
Current consumption	Analog: 50...140 mA, SSI, CANbus & IO-Link: 60 mA
Dielectric strength	500 VDC (DC ground to machine ground)
Polarity protection	Up to -30 VDC
Overvoltage protection	Up to 36 VDC

TECHNICAL DRAWING

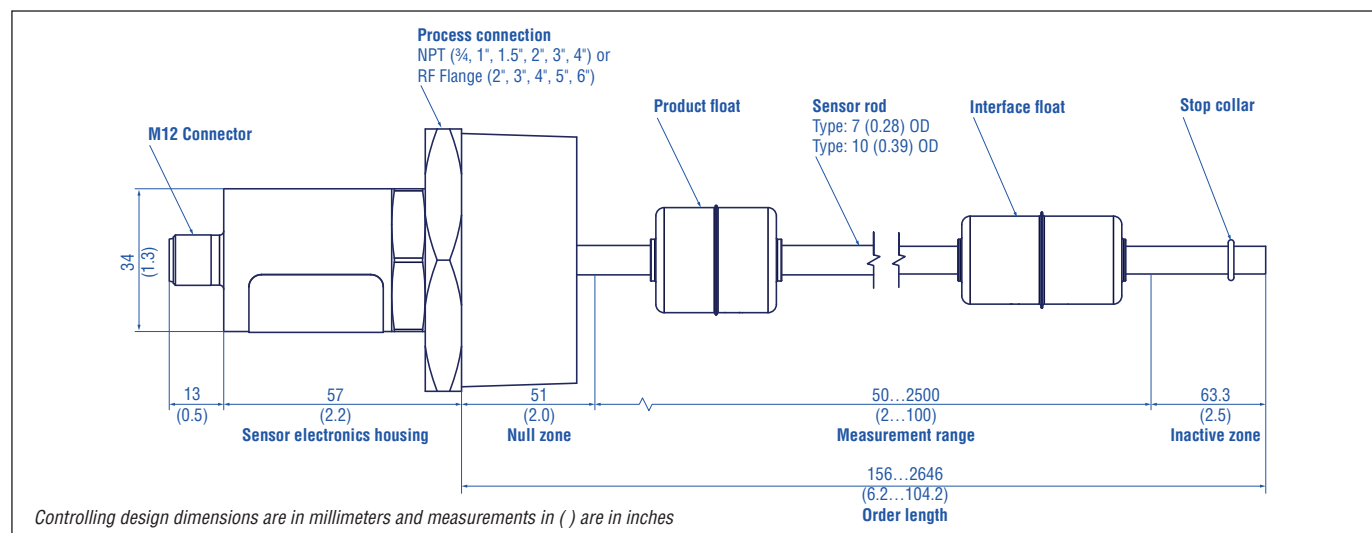

Fig. 3: Technical drawing LLE

CONNECTOR WIRING

D34 Analog		
Signal + power supply		
M12 male connector (A-coded)	Pin	Function
 <p>View on sensor</p>	1	+24 VDC (-15/+20 %)
	2	Output 1
	3	DC Ground (0 V)
	4	Output 2
	5	DC Ground

Fig. 4: D34 Analog

D34 CAN		
Signal + power supply		
M12 male connector (A-coded)	Pin	Function
 <p>View on sensor</p>	1	Shield
	2	+24 VDC (-15/+20 %)
	3	DC Ground (0 V)
	4	CAN_H
	5	CAN_L

Fig. 7: D34 CAN

D84 SSI		
Signal + power supply		
M12 male connector (A-coded)	Pin	Function
 <p>View on sensor</p>	1	Clock (+)
	2	Clock (-)
	3	Data (+)
	4	Data (-)
	5	Not connected
	6	Not connected
	7	+24 VDC (-15/+20 %)
	8	DC Ground (0 V)

Fig. 6: D84 SSI

T84 Analog + RTD		
Signal + power supply		
M12 male connector (A-coded)	Pin	Function
 <p>View on sensor</p>	1	Output 1
	2	DC Ground (0 V)
	3	Output 2
	4	Chassis Ground
	5	RTD
	6	RTD
	7	+24 VDC (-15/+20 %)
	8	DC Ground (0 V)

Fig. 9: T84 Analog + RTD

D44 IO-Link		
Signal + power supply		
M12 A-coded	Pin	Function
	1	+24 VDC (± 25 %)
	2	DI/DQ
	3	DC Ground (0 V)
	4	C/Q

Fig. 8: D44 IO-Link

Level Plus Model LLE

Data Sheet

ORDER CODE

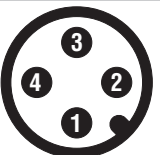
1	2	3	4	5	6	7	8	9	10	11	12	13	14	15	16	17	18	19	20
L	L	E																	
a			b	c					d				e	f	g		h		i

a	Sensor model			
L	L	E	E-Series	

b	Sensors pipe	
G	7 mm 304 SS Pipe	
H	10 mm 316 SS Pipe	

c	Order length				
X	X	X	X	M	0156...2646 mm
X	X	X	X	U	006.2...104.2 in.

d	Output - No Temperature			
V	1	1	0	10...0 Vdc (1 output channel with 1 position magnet)
V	1	2	0	10...0 Vdc (2 output channels with 2 position magnet)
A	1	1	0	20...4 mA (1 output channel with 1 position magnet)
A	1	2	0	20...4 mA (2 output channels with 2 position magnets)
L	0	0	0	IO-Link
S	1	B	0	SSI, 25 bit, Binary, 0.1 mm resolution*
S	1	G	0	SSI, 25 bit, Gray, 0.1 mm resolution*
S	2	B	0	SSI, 24 bit, Binary, 0.1 mm resolution*
S	2	G	0	SSI, 24 bit, Gray, 0.1 mm resolution*
C	3	1	1	CANopen, 1000 kBit/s, 20 um, 1 magnet
C	3	2	1	CANopen, 500 kBit/s, 20 um, 1 magnet
C	3	3	1	CANopen, 250 kBit/s, 20 um, 1 magnet
C	3	4	1	CANopen, 125 kBit/s, 20 um, 1 magnet
C	3	1	2	CANopen, 1000 kBit/s, 20 um, 2 magnets
C	3	2	2	CANopen, 500 kBit/s, 20 um, 2 magnets
C	3	3	2	CANopen, 250 kBit/s, 20 um, 2 magnets
C	3	4	2	CANopen, 125 kBit/s, 20 um, 2 magnets

*/ Measurement direction is set to measure away from housing towards tip.

d	Output			
C	4	1	1	CANopen (bus terminator), 1000 kBit/s, 20 um, 1 magnet
C	4	2	1	CANopen (bus terminator), 500 kBit/s, 20 um, 1 magnet
C	4	3	1	CANopen (bus terminator), 250 kBit/s, 20 um, 1 magnet
C	4	4	1	CANopen (bus terminator), 125 kBit/s, 20 um, 1 magnet
C	4	1	2	CANopen (bus terminator), 1000 kBit/s, 20 um, 2 magnets
C	4	2	2	CANopen (bus terminator), 500 kBit/s, 20 um, 2 magnets
C	4	3	2	CANopen (bus terminator), 250 kBit/s, 20 um, 2 magnets
C	4	4	2	CANopen (bus terminator), 125 kBit/s, 20 um, 2 magnets

d	Output - Temperature			
V	1	1	T	10...0 Vdc (2 output channel) w/RTD
V	1	2	T	10...0 Vdc (2 output channel) w/RTD
A	1	1	T	20...4 mA (1 output channel) w/RTD
A	1	2	T	20...4 mA (2 output channels) w/RTD

Note: Sensor pipe H = 10 mm is required RTD at 2 in. (50 mm) if length is less than 20 in. (508 mm). RTD at 10% of length for all other lengths.

e	Process Connection Type	
1	NPT	
6	150# RF Flange	
S	SAE	
Z	Custom Flange	
f	See next page	

f	Process Connection Size
A	¾"
B	1"
C	1½"
D	2"
E	2½"
F	3"
G	4"
H	5"
S	SAE 5 bolt
3	SAE-12

i	Options
B	Stop Collar and Cable
C	5 m cable
S	Stop Collar
X	None

Manuals, Software & 3D models available at:
www.temposonics.com

g	Float 1
7 0	404834 *
7 1	404835 **
7 2	201999
1 0	561612
1 1	254886
1 2	201120
L 1	251981-2 ***
L 2	254526-2 ***
L 3	201250-2 ***
L 4	252961-2 ***
L 5	201232-2 ***
L 6	251982-2 ***
L 7	254894-2 ***
L 8	252962-2 ***
L 9	201233-2 ***

h	Float 2
X X	None
L 6	251982-2
L 7	254894-2
L 8	252962-2
L 9	201233-2

**/ requires G = 7 mm pipe

***/ requires Options B or S with Stop Collar for larger I.D. floats. Not to be used with 7 mm pipe.

ACCESSORY DETAILS – Accessories shown can be included in the model number when selected.

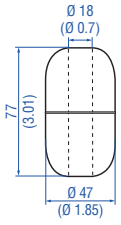
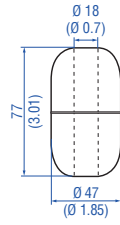
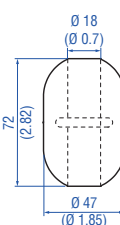
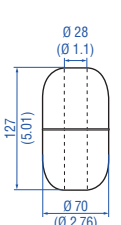
Floats			
			
Float Part no. 251 981-2	Float Part no. 251 982-2	Float Part no. 254 526-2	Float Part no. 201 232-2
Material: Stainless steel (AISI 316L) Pressure: 29.3 bar (425 psi) Specific gravity: Max. 0.67 Operating temperature: -40...+125 °C (-40...+257 °F)	Material: Stainless steel (AISI 316L) Pressure: 29.3 bar (425 psi) Specific gravity: Max. 0.67 Operating temperature: -40...+125 °C (-40...+257 °F)	Material: Stainless steel (AISI 316) Specific gravity: Max. 0.68 Pressure: Max. 69 bar (1000 psi) Operating temperature: -40...+149 °C (-40...+300 °F)	Material: Stainless steel (AISI 316) Specific gravity: Max. 0.70 Pressure: Max. 22.4 bar (250 psi) Operating temperature: -40...+149 °C (-40...+300 °F)

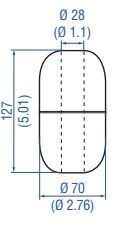
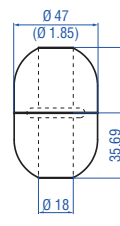
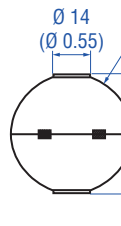
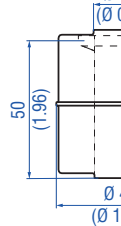
Floats			
			
Float Part no. 201 233-2	Float Part no. 254 894-2	Float Part no. 561 612	Float Part no. 254 886
Material: Stainless steel (AISI 316) Specific gravity: Max. 0.70 Pressure: Max. 22.4 bar (250 psi) Operating temperature: -40...+149 °C (-40...+300 °F)	Material: Stainless steel (AISI 316) Specific gravity: Max. 0.93 Pressure: Max. 69 bar (1000 psi) Operating temperature: -40...+149 °C (-40...+300 °F)	Material: Stainless steel (AISI 304) Density: 720 kg/m ³ Specific gravity: Max. 0.61 Pressure: Max. 40 bar Operating temperature: -40...+125 °C	Material: PP, Moplen5, red Specific gravity: Max. 0.53 g/cm ³ Pressure: Max. 4 bar Operating temperature: -20...+80 °C

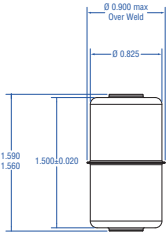
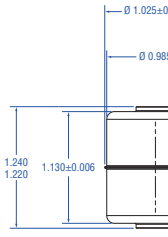
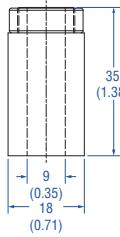
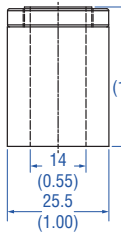
Float			
			
Float Part no. 404 834	Float Part no. 404 835	Float Part no. 201 199	Float Part no. 201 120
Material: Stainless steel (AISI 316) Weight: Ca. 42 ± 3 g Specific gravity: Max. 0.72 Pressure: Max. 10.3 bar (150 psi) Operating temperature: -40...+125 °C (-40...+257 °F)	Material: Stainless steel (AISI 316) Weight: Ca. 42 ± 3 g Specific gravity: Max. 0.72 Pressure: Max. 19 bar (275 psi) Operating temperature: -40...+125 °C (-40...+257 °F)	Material: Nitrile Specific gravity: Max. 0.7 Pressure: Max. 17.2 bar (250 psi) Operating temperature: -40...104 °C (-40...220 °F)	Material: Nitrile Specific gravity: Max. 0.75 Pressure: Max. 17.2 bar (250 psi) Operating temperature: -40...104 °C (-40...220 °F)

ACCESSORY DETAILS – Accessories shown can be included in the model number when selected.

Floats **Collar**

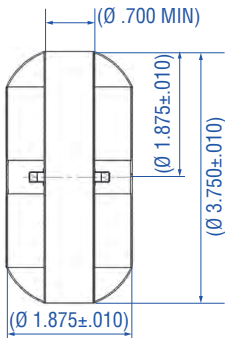

Float
Part no. 201 250-2

Material: Titanium
Specific gravity: Max. 0.4
Pressure: Max. 20.7 bar (300 psi)
Operating temperature:
–40...150 °C (–40...66 °F)

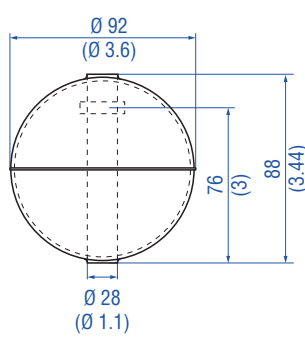

Float
Part no. 252 961-2

Material: Stainless steel (AISI 316)
Weight: Ca. 42 ± 3 g
Specific gravity: Max. 0.54
Pressure: Max. 29.3 bar (425 psi)
Operating temperature:
–40...+149 °C (–40...+300 °F)

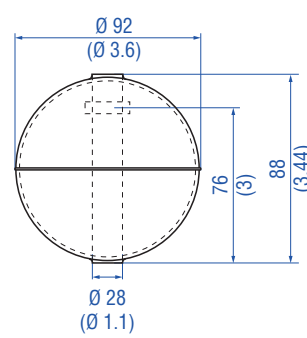

Float
Part no. 252 962-2

Material: Stainless steel (AISI 316)
Weight: Ca. 42 ± 3 g
Specific gravity: Max. 0.93
Pressure: Max. 29.3 bar (425 psi)
Operating temperature:
–40...+149 °C (–40...+300 °F)

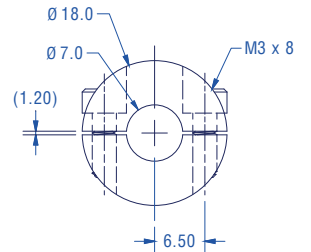

Stop collar for Ø 7 mm
Part no. 562 392

Provides end of stroke stops for float
Material: Stainless steel 1.4305 (AISI 303)
Hex key 2.5 mm required

Collar **Cord sets**

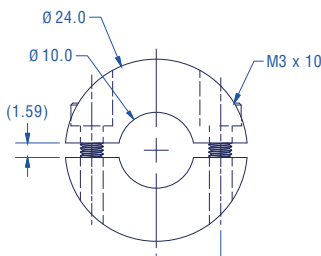

O-ring Stop for 10 mm pipe
Part no. 562 348

Provides end of stroke stops for float
Material: Stainless steel (AISI 316)



O-ring Stop for 10 mm pipe
Part no. 562 355

Provides end of stroke stops for float
Material: Viton



O-ring Stop for 7 mm pipe
Part no. 562 354

Provides end of stroke stops for float
Material: Viton

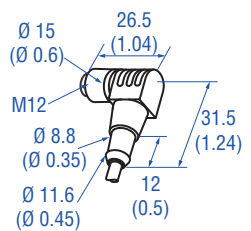

Cable with M12 A-coded female connector (5 pin), angled – pigtail
Part no. 370 675

Material: PUR jacket; black
Features: Shielded
Cable length: 5 m (16.4 ft)
Ingress protection: IP67 (correctly fitted)
Operating temperature:
–25...+80 °C (–13...+176 °F)

Cord sets

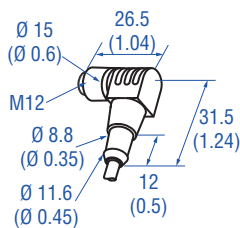

Cable with M12 A-coded female connector (8 pin), angled – pigtail
Part no. 370 676

Cable: Shielded
Cable length: 5 m (16.4 ft)
Ingress protection: IP67 (correctly fitted)

Document Part Number:

552100 Revision A (EN) 02/2023

UNITED STATES
Temposonics, LLC
Americas & APAC Region
3001 Sheldon Drive
Cary, N.C. 27513
Phone: +1 919 677-0100
E-mail: info.us@temposonics.com

GERMANY
Temposonics
GmbH & Co. KG
EMEA Region & India
Auf dem Schüffel 9
58513 Lüdenscheid
Phone: +49 2351 9587-0
E-mail: info.de@temposonics.com

ITALY
Branch Office
Phone: +39 030 988 3819
E-mail: info.it@temposonics.com

FRANCE
Branch Office
Phone: +33 6 14 060 728
E-mail: info.fr@temposonics.com

UK
Branch Office
Phone: +44 79 21 83 05 86
E-mail: info.uk@temposonics.com

SCANDINAVIA
Branch Office
Phone: +46 70 29 91 281
E-mail: info.sca@temposonics.com

CHINA
Branch Office
Phone: +86 21 3405 7850
E-mail: info.cn@temposonics.com

JAPAN
Branch Office
Phone: +81 3 6416 1063
E-mail: info.jp@temposonics.com



temposonics.com