

# BREATHERS

## HydroGuard®

Protection from moisture and particulate contamination in low-flow, steady-state operations.



### APPLICATIONS

- Totes
- Transformers
- Storage Tanks
- Hydraulics



# Overview

## HydroGuard Breathers: The Highlights

- Expansion chamber and internal check-valve system create a nearly-sealed system
- Eliminates rust-forming condensation
- Prevents sludge deposits and water-contaminated oil
- Provides longer oil and filter life
- Reduces wear and tear on equipment, prolongs life

## By the Numbers:

### 1-Domed Cap

A domed cap allows for better washdown runoff

### 2-Expansion Chamber

The diaphragm allows for expansion/contraction of the air within the casing as a result of temperature variations during steady-state operations.

### 3-External Ribs

External ribs on shell to create greater durability and grip when installing or replacing breather

### 4-Integrated Nylon Standpipe

The integrated standpipe provides excellent vibration resistance and dissipates impact throughout the unit, eliminating weak points. It also allows even airflow distribution throughout the unit, eliminating inaccurate readings of desiccant saturation.

### 5-Integrated Drip Ring

An integrated drip ring keeps shedding water from entering the vent holes

### 6-Threaded Mounting

Easily replaces standard filler/breather cap with multi-fit connection or one of several adapters.

### 7-Larger, High-Capacity Check Valves

High-capacity check valves allow for increased airflow at low cracking pressure.

### 8-Filter Element

Polyester filter element removes airborne contamination to 3-micron absolute. Unique loops allow particles to release during system exhalation, helping to increase breather life.

### 9-Enhanced Seal

An enhanced seal eliminates potential for airflow bypass

## How It Works:

As wet, contaminated air is drawn through the unit, multiple 3-micron polyester filter elements remove solid particulate while the color-indicating silica gel extracts moisture.

The diaphragm allows for expansion/contraction of the air within the casing as a result of temperature variations during steady-state operations.

When air is expelled from the container, the top foam pad prevents oil mist from contacting silica gel or entering the atmosphere.



# Specifications

## Materials & Components:

**Housing:** Polycarbonate, Nylon 6/6 30% Glass Filled, Polypropylene

**Seals (DC-HG-1):** Buna-N, EPDM, PVC

**Seals (DC-HG-8):** Buna-N, PVC

**Filter Media:** Polyurethane, Polyester

**Hydrophilic Media:** Silica gel

## Filter Efficiency:

(3 $\mu$  absolute ( $\beta_3 \geq 200$ ))

## Recommended Temperature Range:

-20°F to 200°F

-29°C to 93°C

## Chemical Compatibility:

Compatible with all mineral oils, most synthetic oils and diesel (Contact Des-Case technical support for chemical compatibility inquiries)

## Certificates and Approvals:

Upon request

	DC-HG-1	DC-HG-8
Amount of Desiccant:	.3 lbs / .1 kg	.8 lbs / .4 kg
Adsorption Capacity:	2 fl oz / 50 ml	5 fl oz / 144 ml
Air Flow Rate:	1 cfm @ 1 Psid	7 cfm @ 1 Psid
Flow Rate:	11 gpm / 40 lpm	52 gpm / 198 lpm

## Did You Know?

HydroGuard breathers were specifically designed for steady-state operations with minimal temperature fluctuations. These breathers provide excellent protection in continuous duty applications. For check-valve protection in intermittent operating conditions, try a VentGuard instead.

## Sizing / Flow Rate

Model	Suction / Return Rate (gpm / lpm)	Gearbox / Storage Tank Reservoir Size (Gallons / Liters)	Hydraulic Reservoir Size (Gallons / Liters)
DC-HG-1	11 / 40	50 / 189	N/A
DC-HG-8	52 / 198	400 / 1514	55 / 208

*Please Note: This is intended as a general guideline for sizing only; other considerations, such as: humidity level, frequency of air flow, ambient temperatures, and chemical compatibility are very important in sizing a breather properly. Larger applications and special circumstances typically require the most thorough analysis. Please contact Des-Case for assistance in sizing a breather.*

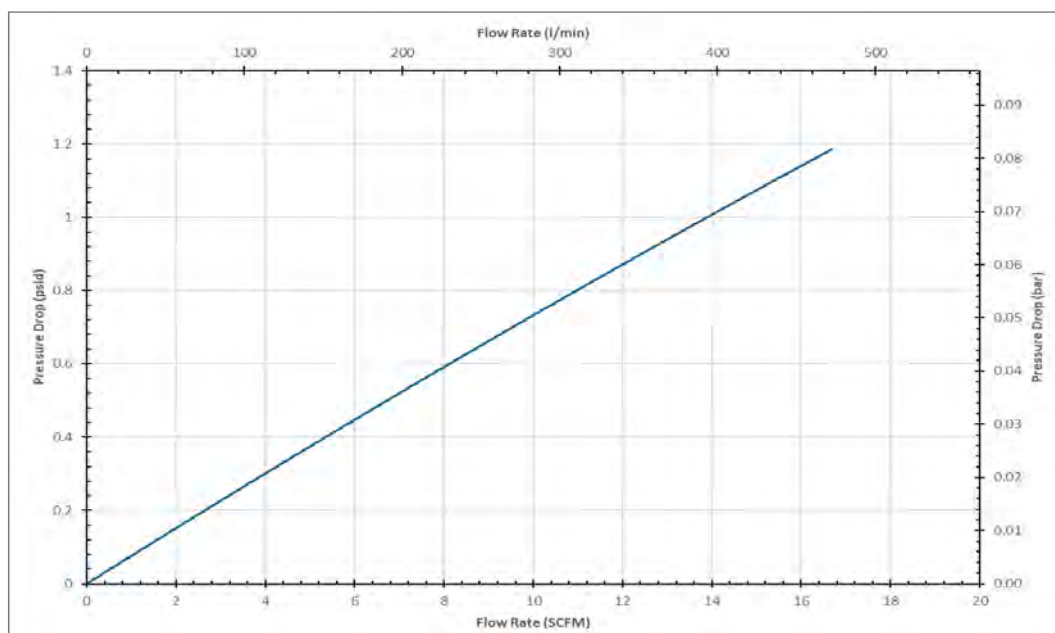

— DC-HG-8

# Specifications

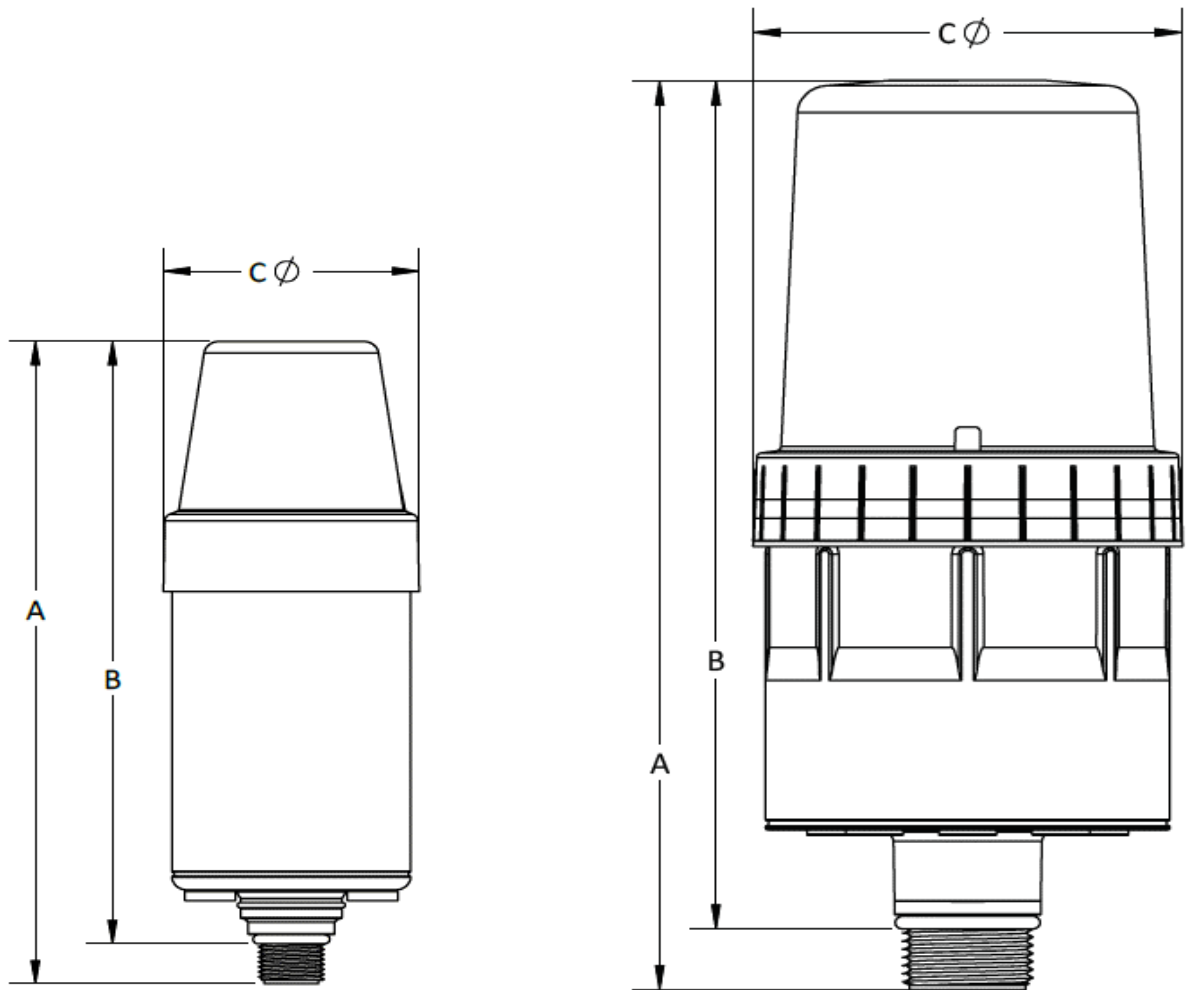

Dimension Table

	Style	A	B	C	Thread Size
Part Code	Miniature or Standard	inch / mm	inch / mm	inch / mm	
DC-HG-1	Miniature	7.19 / 182	6.74 / 171	2.52 / 64	3/8" Multi-Fit Male Thread with O-Ring Seal, Compatible with: 3/8" NPT; 3/8" BSPT; 3/8" BSPP
DC-HG-8	Standard	9.73 / 247	9.07 / 230.3	4.10 / 104	1" Multi-Fit Male Thread with O-Ring Seal, Compatible with: 1" NPT; 1" NPSM; 1" BSPT; 1" BSPP