

ISO 6432, Series CSL-RD



AVENTICS™ ISO 6432, Series CSL-RD



Mini cylinder, Series CSL-RD

- Version: ISO model
- Ø 16-25 mm
- Ports M5 G 1/8
- double-acting
- with magnetic piston
- Cushioning elastic non-adjustable
- with integrated rear eye
- Piston rod External thread
- ATEX optional
- suitable for use in food processing



Standards	ISO 6432
Certificates	ATEX optional
Compressed air connection	Internal thread
Working pressure min./max.	1 ... 10 bar
Ambient temperature min./max.	-20 ... 80 °C
Medium temperature min./max.	-20 ... 80 °C
Medium	Compressed air
Max. particle size	50 µm
Oil content of compressed air	0 ... 5 mg/m ³
Pressure for determining piston forces	6.3 bar

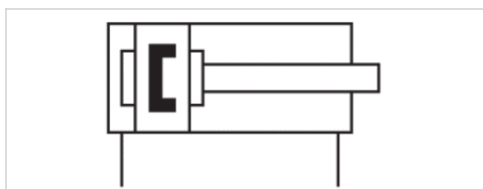

Technical data

Piston Ø Piston rod thread Ports Piston rod Ø	16 mm M6 M5 6 mm	20 mm M8 G 1/8 8 mm	25 mm M10x1,25 G 1/8 10 mm
Stroke 25	R412020398	R412020442	R412020486
50	R412020399	R412020443	R412020487
80	R412020400	R412020444	R412020488
100	R412020401	R412020445	R412020489
125	R412020402	R412020446	R412020490
160	R412020403	R412020447	R412020491
200	R412020404	R412020448	R412020492
250	R412020405	R412020449	R412020493
320	R412020406	R412020450	R412020494
400	R412020407	R412020451	R412020495
500	R412020408	R412020452	R412020496

Technical data

Piston Ø	16 mm	20 mm	25 mm
Retracting piston force	109 N	166 N	260 N
Extracting piston force	127 N	198 N	309 N
Impact energy	0.14 J	0.23 J	0.35 J
Weight 0 mm stroke	0.034 kg	0.063 kg	0.082 kg
Weight +10 mm stroke	0.002 kg	0.005 kg	0.006 kg
Stroke max.	800 mm	1100 mm	1200 mm

Technical information

The pressure dew point must be at least 15 °C under ambient and medium temperature and may not exceed 3 °C .

The oil content of compressed air must remain constant during the life cycle.

Use only the approved oils from AVENTICS. Further information can be found in the "Technical information" document (available in the MediaCentre).

Clamping piece for magnetic field sensor necessary

ATEX-certified cylinders with identification II 2G Ex h IIB T4 Gb / II 2D Ex h IIIB T135°C Db_X can be generated in the Internet configurator.

Technical information

Material	
Cylinder tube	Stainless steel
Piston rod	Stainless steel
Piston	Aluminum
Front cover	Stainless steel, Electropolished
End cover	Stainless steel, Electropolished
Seal	Nitrile butadiene rubber
Nut for cylinder mounting	Stainless steel
Nut for piston rod	Stainless steel
Scraper	Thermoplastic polyurethane (TPU)
Guide bushing	Plastic

Dimensions

Dimensions

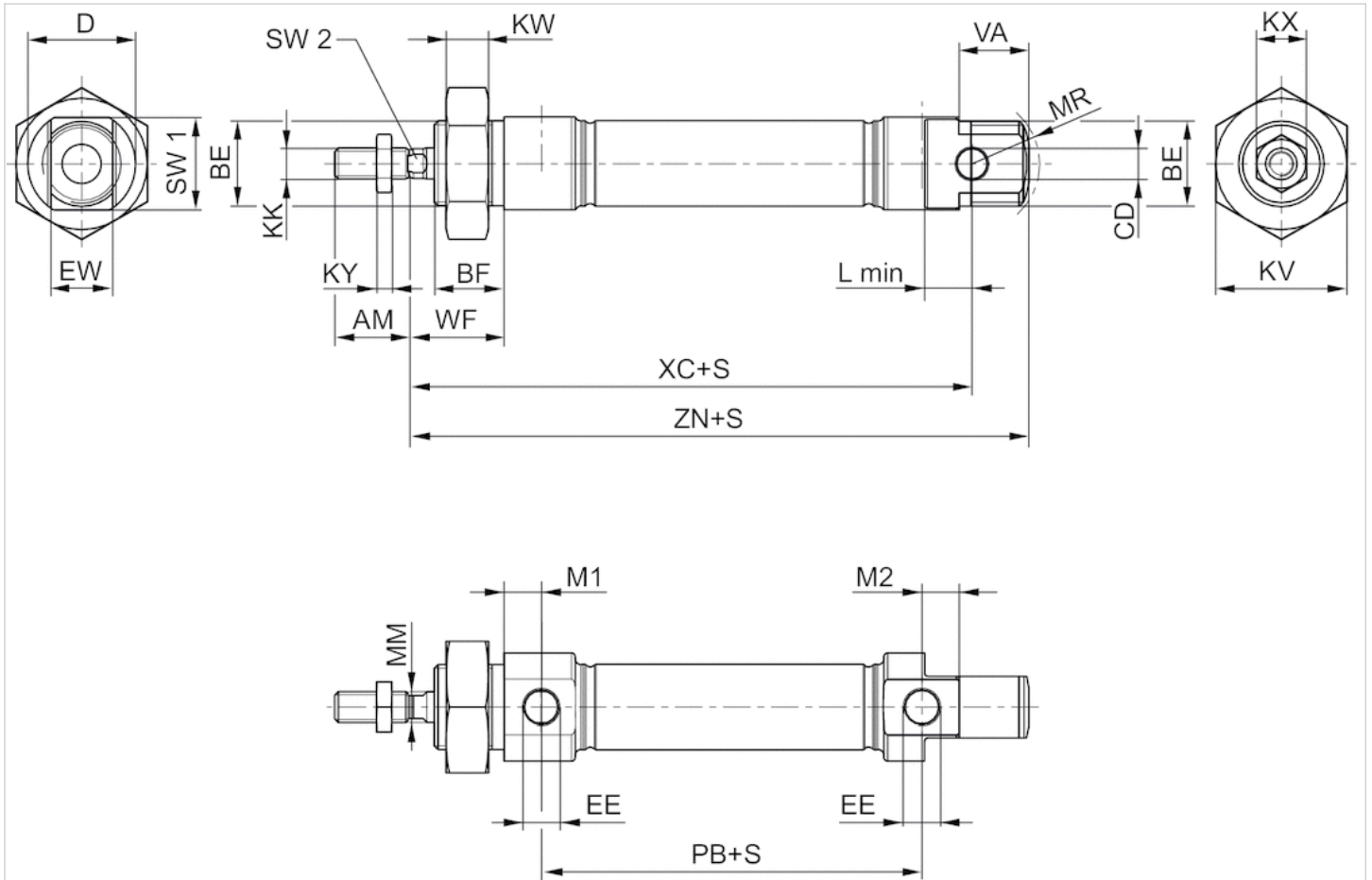

S = stroke

Dimensions

Piston Ø	AM-2	BE	BF	CD H9	D	EE t = depth of thread	EW d13	KK	KV	KW	KX
16 mm	16	M16x1,5	16	6	22	M5 t=5	12	M6	24	8	10
20 mm	20	M22x1,5	18	8	28	G 1/8 t=8	16	M8	32	11	13
25 mm	22	M22x1,5	20	8	33	G 1/8 t=8	16	M10x1,25	32	11	17

Piston Ø	KY	L min	M1/M2	MM f8	MR	PB ±1	VA	WF ±1,4	XC ±1	ZN ± 1	SW 1	SW 2
16 mm	3.2	9	6.7	6	16	43.6	16	22	82	94.7	20	5
20 mm	4	12	9.7	8	18	48.6	18	24	95	109.7	24	6
25 mm	5	12	9.7	10	19	52.6	20	28	104	119.7	28	8

Accessories overview

Overview drawing

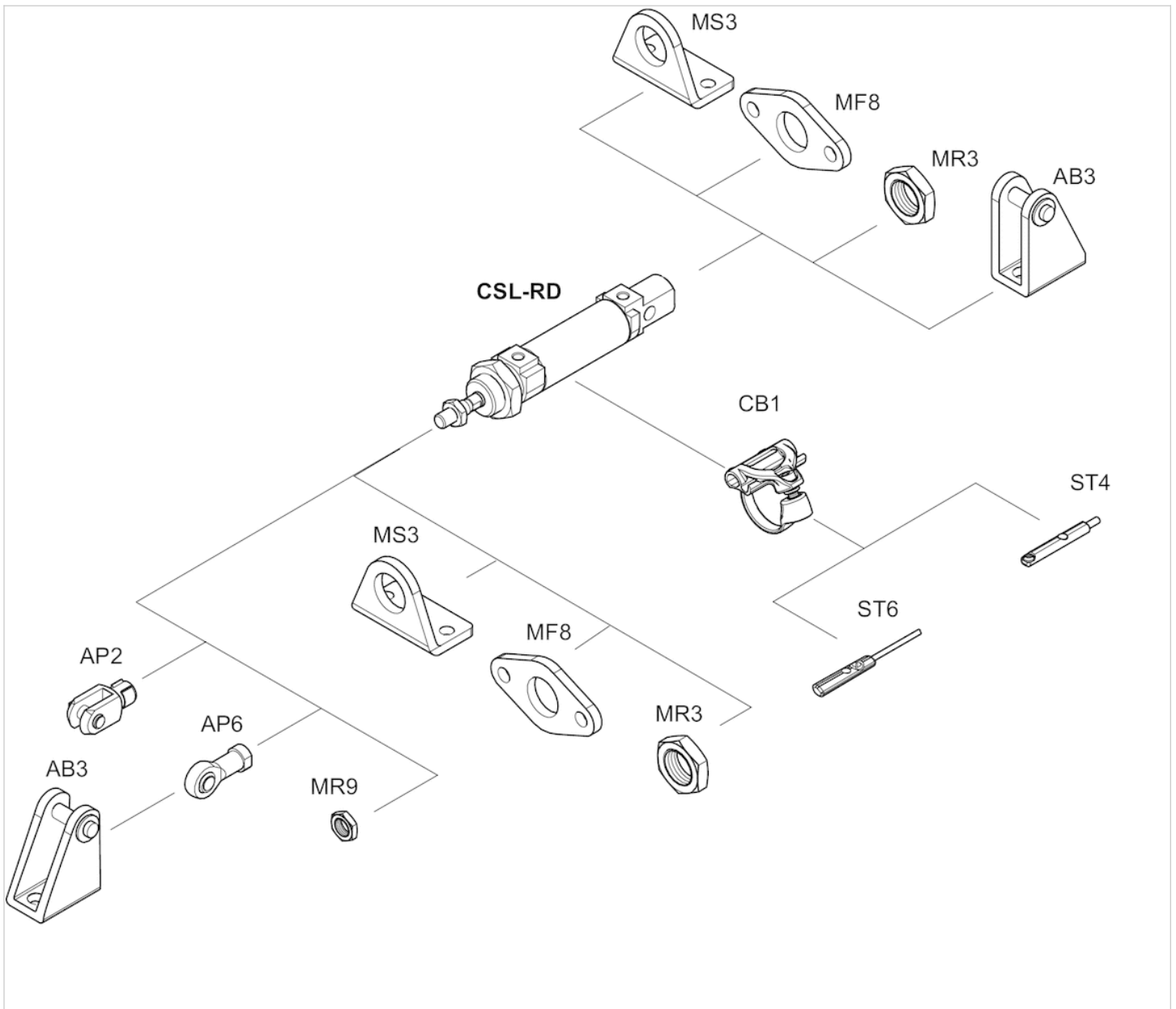

NOTE:

This overview drawing is only for orientation to indicate where the various accessory parts can be fastened to the cylinder. The illustration has been simplified for this purpose. It is thus not possible to derive the dimensions from this overview.

Mini cylinder, Series CSL-RD

- Version: mini type
- Ø 16-25 mm
- Ports M5 G 1/8
- double-acting
- with magnetic piston
- Cushioning elastic non-adjustable
- Piston rod External thread
- ATEX optional
- suitable for use in food processing



Certificates	ATEX optional
Compressed air connection	Internal thread
Working pressure min./max.	1 ... 10 bar
Ambient temperature min./max.	-20 ... 80 °C
Medium temperature min./max.	-20 ... 80 °C
Medium	Compressed air
Max. particle size	50 µm
Oil content of compressed air	0 ... 5 mg/m ³
Pressure for determining piston forces	6.3 bar

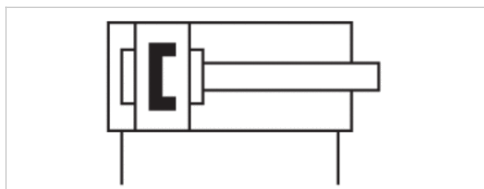

Technical data

Piston Ø Piston rod thread Ports Piston rod Ø	16 mm M6 M5 6 mm	20 mm M8 G 1/8 8 mm	25 mm M10x1,25 G 1/8 10 mm
Stroke 25	R412021846	R412021857	R412021868
50	R412021847	R412021858	R412021869
80	R412021848	R412021859	R412021870
100	R412021849	R412021860	R412021871
125	R412021850	R412021861	R412021872
160	R412021851	R412021862	R412021873
200	R412021852	R412021863	R412021874
250	R412021853	R412021864	R412021875
320	R412021854	R412021865	R412021876
400	R412021855	R412021866	R412021877
500	R412021856	R412021867	R412021878

Technical data

Piston Ø	16 mm	20 mm	25 mm
Retracting piston force	109 N	166 N	260 N
Extracting piston force	127 N	198 N	309 N
Impact energy	0.14 J	0.23 J	0.35 J
Weight 0 mm stroke	0.034 kg	0.063 kg	0.082 kg
Weight +10 mm stroke	0.002 kg	0.005 kg	0.006 kg
Stroke max.	800 mm	1100 mm	1200 mm

Technical information

The pressure dew point must be at least 15 °C under ambient and medium temperature and may not exceed 3 °C .

The oil content of compressed air must remain constant during the life cycle.

Use only the approved oils from AVENTICS. Further information can be found in the "Technical information" document (available in the MediaCentre).

Clamping piece for magnetic field sensor necessary

ATEX-certified cylinders with identification II 2G Ex h IIB T4 Gb / II 2D Ex h IIIB T135°C Db_X can be generated in the Internet configurator.

The operating temperature range for ATEX-certified cylinders is -20 °C ... 50 °C.

Based on ISO 6432

Technical information

Material	
Cylinder tube	Stainless steel
Piston rod	Stainless steel
Piston	Aluminum
Front cover	Stainless steel, Electropolished
End cover	Stainless steel, Electropolished
Seal	Nitrile butadiene rubber
Nut for cylinder mounting	Stainless steel
Nut for piston rod	Stainless steel
Scraper	Thermoplastic polyurethane (TPU)
Guide bushing	Plastic

Dimensions

Dimensions

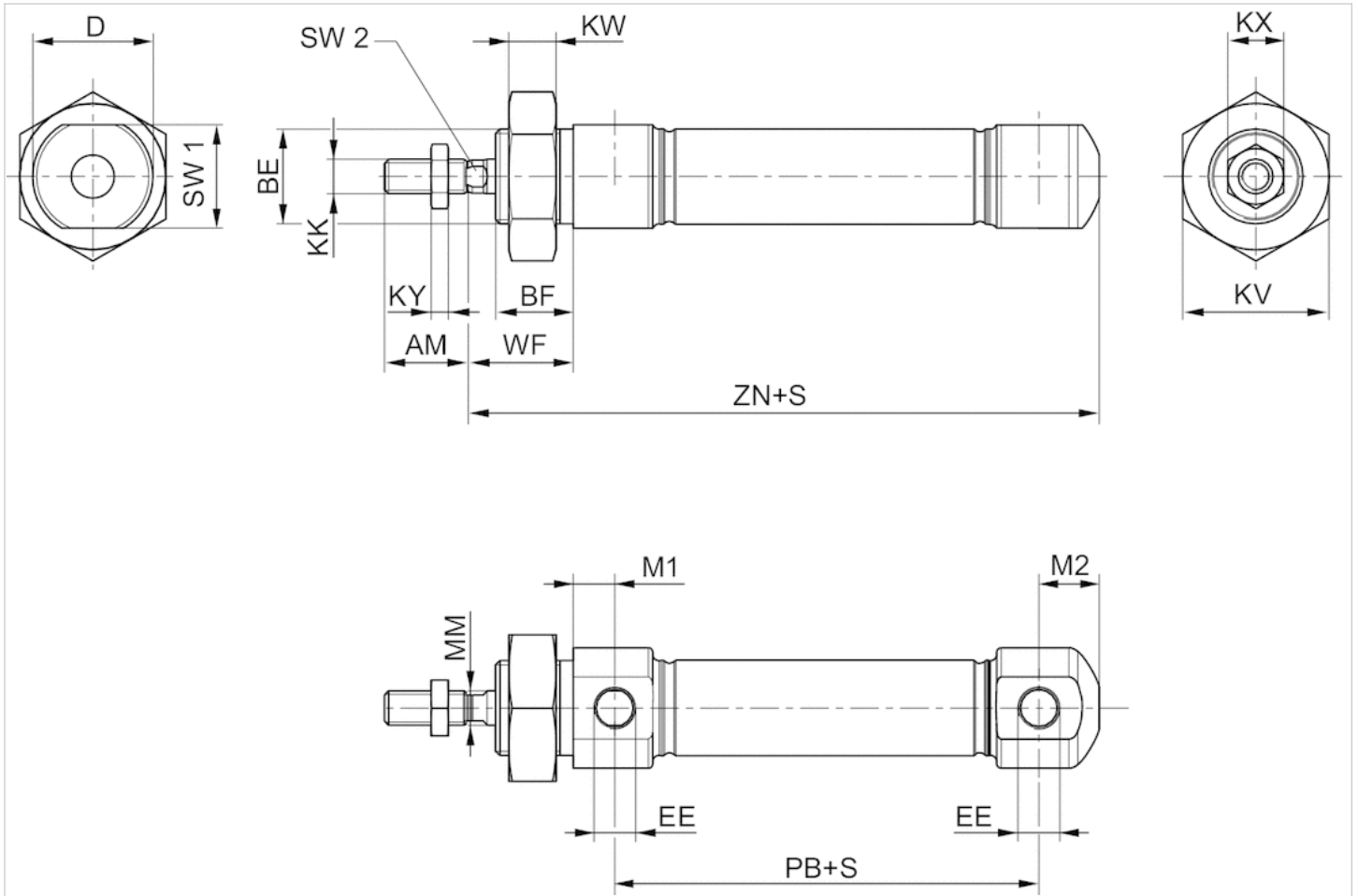

S = stroke

Dimensions

Piston Ø	AM-2	BE	BF	D	EE t = depth of thread	KK	KV	KW	KX	KY	M1	M2
16 mm	16	M16x1,5	16	22	M5 t=5	M6	24	8	10	3.2	6.7	10
20 mm	20	M22x1,5	18	28	G 1/8 t=8	M8	32	11	13	4	9.7	14
25 mm	22	M22x1,5	20	33	G 1/8 t=8	M10x1,25	32	11	17	5	9.7	14

Piston Ø	MM f8	PB ±1	WF ±1,4	ZN ± 1	SW 1	SW 2
16 mm	6	43.6	22	82	20	5
20 mm	8	48.6	24	96	24	6
25 mm	10	52.6	28	104	28	8

Accessories overview

Overview drawing

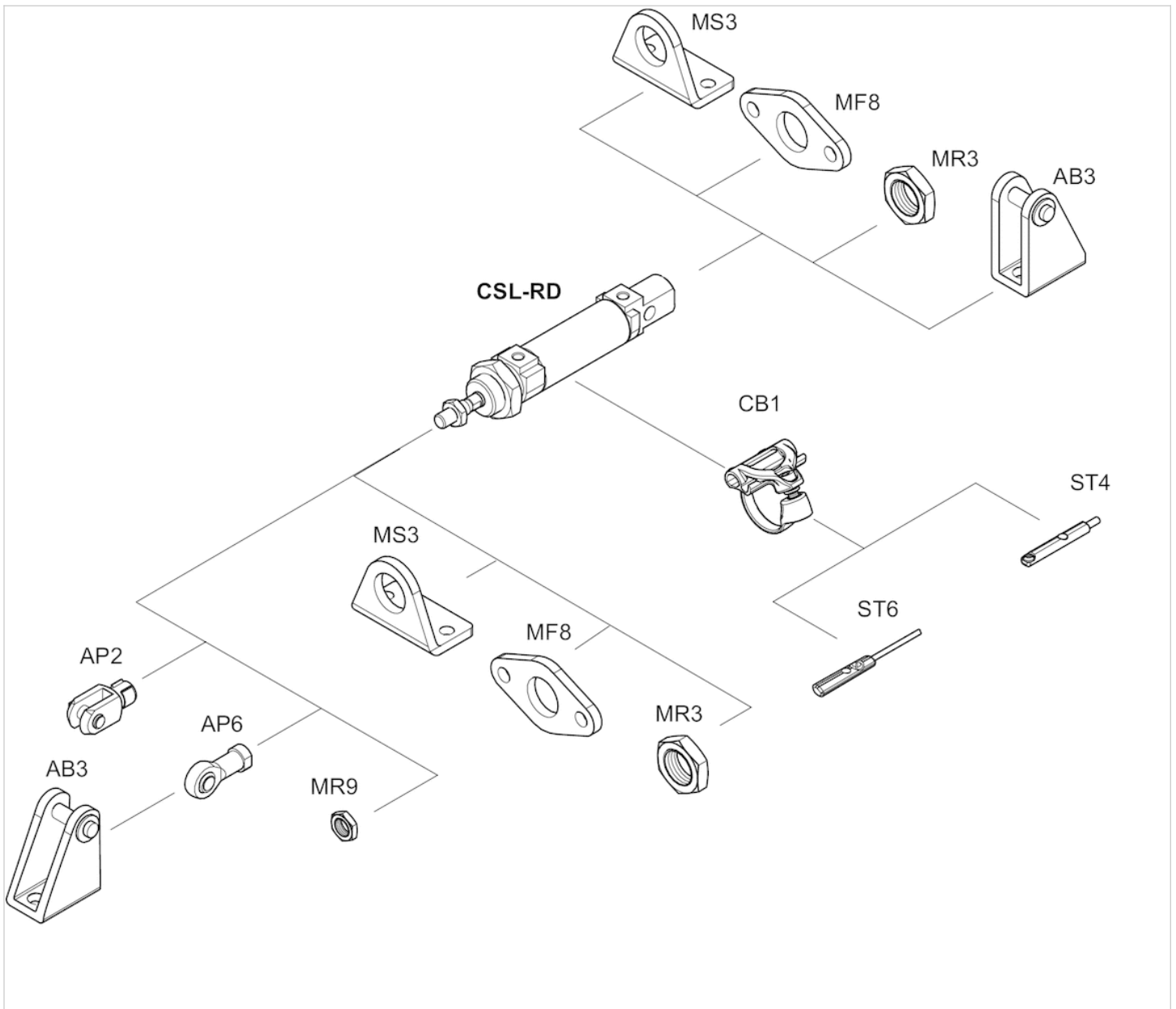

NOTE:

This overview drawing is only for orientation to indicate where the various accessory parts can be fastened to the cylinder. The illustration has been simplified for this purpose. It is thus not possible to derive the dimensions from this overview.

Mini cylinder, Series CSL-RD

- Version: hygienic design
- Ø 16-25 mm
- Ports M5 G 1/8
- double-acting
- with magnetic piston
- Cushioning elastic non-adjustable
- with integrated rear eye
- Piston rod External thread
- ATEX optional
- suitable for use in food processing



Standards	ISO 6432
Certificates	ATEX optional
Compressed air connection	Internal thread
Working pressure min./max.	1 ... 10 bar
Ambient temperature min./max.	-20 ... 80 °C
Medium temperature min./max.	-20 ... 80 °C
Medium	Compressed air
Max. particle size	50 µm
Oil content of compressed air	0 ... 5 mg/m ³
Pressure for determining piston forces	6.3 bar



Technical data

Piston Ø Piston rod thread Ports Piston rod Ø	16 mm M6 M5 6 mm	20 mm M8 G 1/8 8 mm	25 mm M10x1,25 G 1/8 10 mm
Stroke 25	R412020420	R412020464	R412020508
50	R412020421	R412020465	R412020509
80	R412020422	R412020466	R412020510
100	R412020423	R412020467	R412020511
125	R412020424	R412020468	R412020512
160	R412020425	R412020469	R412020513
200	R412020426	R412020470	R412020514
250	R412020427	R412020471	R412020515
320	R412020428	R412020472	R412020516
400	R412020429	R412020473	R412020517
500	R412020430	R412020474	R412020518

Technical data

Piston Ø	16 mm	20 mm	25 mm
Retracting piston force	109 N	166 N	260 N
Extracting piston force	127 N	198 N	309 N
Impact energy	0.14 J	0.23 J	0.35 J
Weight 0 mm stroke	0.034 kg	0.063 kg	0.082 kg
Weight +10 mm stroke	0.002 kg	0.005 kg	0.006 kg
Stroke max.	800 mm	1100 mm	1200 mm

Technical information

The pressure dew point must be at least 15 °C under ambient and medium temperature and may not exceed 3 °C .

The oil content of compressed air must remain constant during the life cycle.

Use only the approved oils from AVENTICS. Further information can be found in the "Technical information" document (available in the MediaCentre).

Clamping piece for magnetic field sensor necessary

ATEX-certified cylinders with identification II 2G Ex h IIB T4 Gb / II 2D Ex h IIIB T135°C Db_X can be generated in the Internet configurator.

The operating temperature range for ATEX-certified cylinders is -20 °C ... 50 °C.

Technical information

Material	
Cylinder tube	Stainless steel
Piston rod	Stainless steel
Piston	Aluminum
Front cover	Stainless steel, Electropolished
End cover	Stainless steel, Electropolished
Seal	Nitrile butadiene rubber
Nut for cylinder mounting	Stainless steel
Nut for piston rod	Stainless steel
Scraper	Thermoplastic polyurethane (TPU)
Guide bushing	Plastic

Dimensions

Dimensions

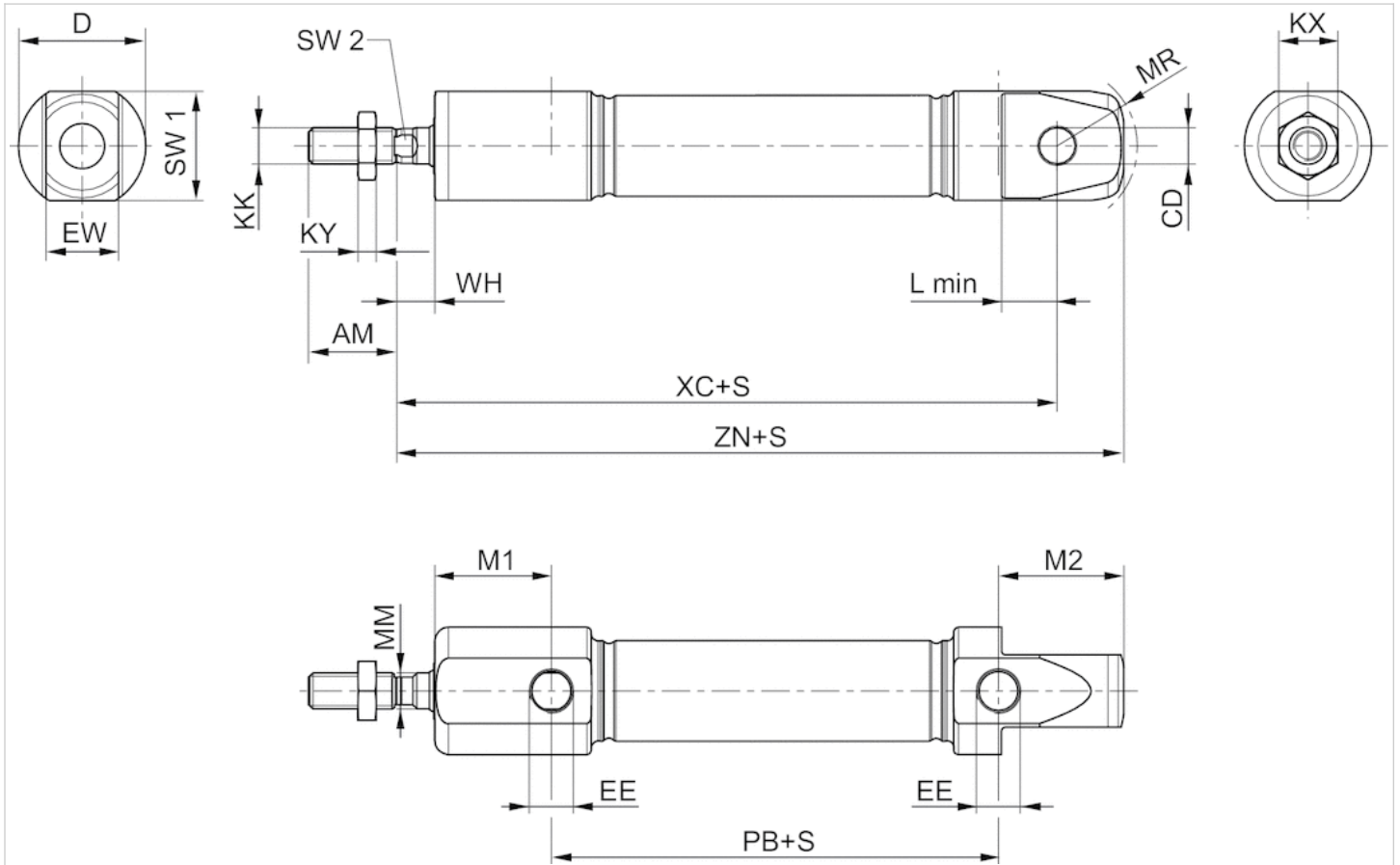

S = stroke

Dimensions

Piston Ø	AM-2	CD H9	D	EE t = depth of thread	EW d13	KK	KX	KY	L min	M1	M2
16 mm	16	6	22	M5 t=5	12	M6	10	3.2	9	21.2	22.7
20 mm	20	8	28	G 1/8 t=8	16	M8	13	4	12	25.7	27.7
25 mm	22	8	33	G 1/8 t=8	16	M10x1,25	17	5	12	28.2	29.7

Piston Ø	MM f8	MR	PB ±1	WH ±1,4	XC ±1	ZN ± 1	SW 1	SW 2
16 mm	6	16	43.6	7.5	82	94.7	20	5
20 mm	8	18	48.6	8	95	109.7	24	6
25 mm	10	19	52.6	9.5	104	119.7	28	8

Accessories overview

Overview drawing

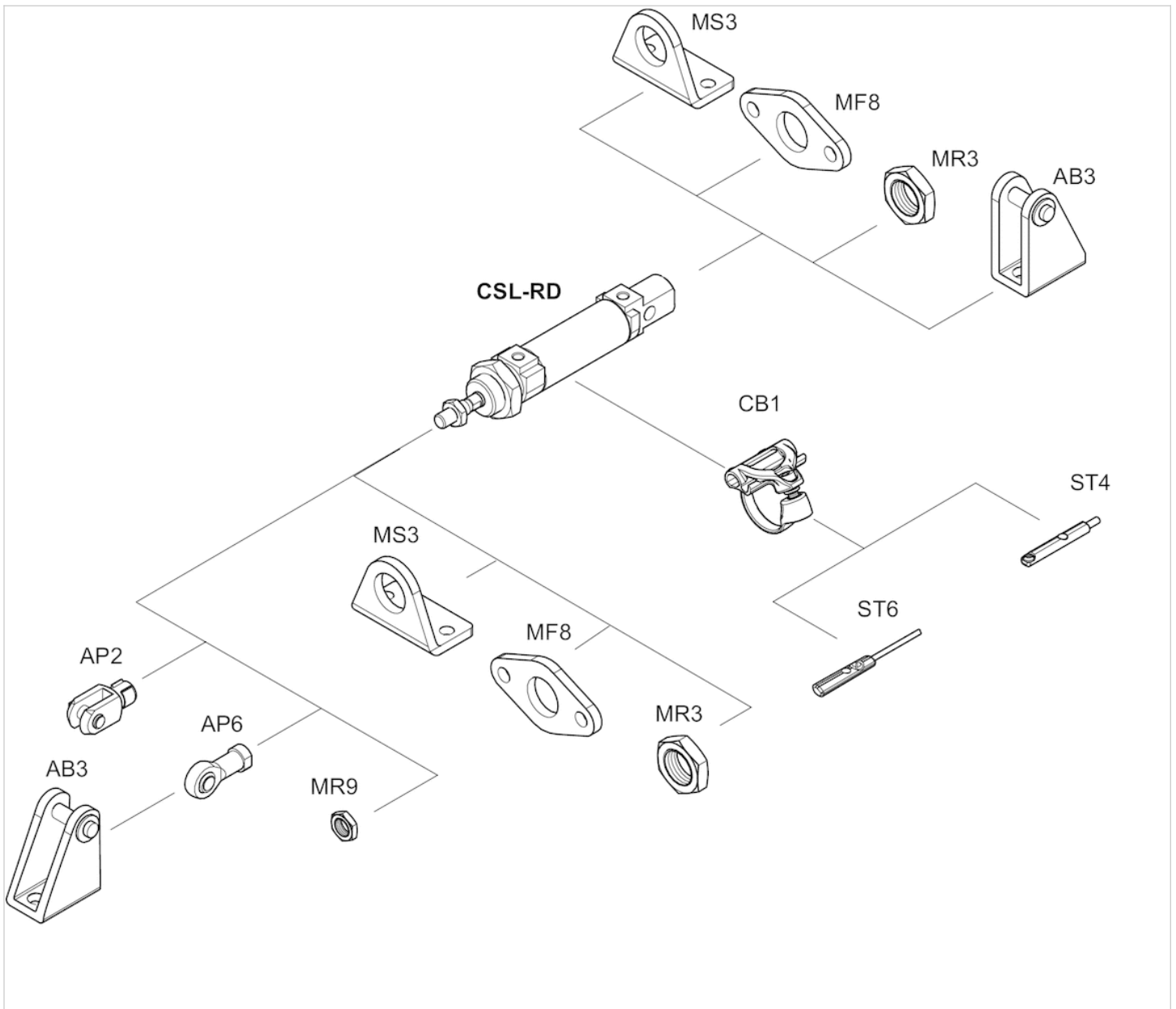

NOTE:

This overview drawing is only for orientation to indicate where the various accessory parts can be fastened to the cylinder. The illustration has been simplified for this purpose. It is thus not possible to derive the dimensions from this overview.

Mini cylinder, Series CSL-RD

- Version: ISO model
- Ø 16-25 mm
- Ports M5 G 1/8
- double-acting
- with magnetic piston
- Cushioning pneumatically adjustable
- with integrated rear eye
- Piston rod External thread
- ATEX optional
- suitable for use in food processing



Standards	ISO 6432
Certificates	ATEX optional
Compressed air connection	Internal thread
Working pressure min./max.	1 ... 10 bar
Ambient temperature min./max.	-20 ... 80 °C
Medium temperature min./max.	-20 ... 80 °C
Medium	Compressed air
Max. particle size	50 µm
Oil content of compressed air	0 ... 5 mg/m ³
Pressure for determining piston forces	6.3 bar

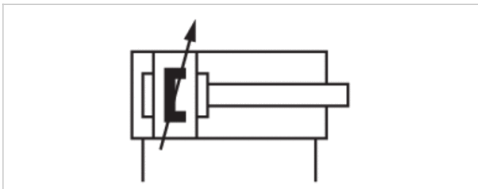

Technical data

Piston Ø Piston rod thread Ports Piston rod Ø	16 mm M6 M5 6 mm	20 mm M8 G 1/8 8 mm	25 mm M10x1,25 G 1/8 10 mm
Stroke 25	R412020409	R412020453	R412020497
50	R412020410	R412020454	R412020498
80	R412020411	R412020455	R412020499
100	R412020412	R412020456	R412020500
125	R412020413	R412020457	R412020501
160	R412020414	R412020458	R412020502
200	R412020415	R412020459	R412020503
250	R412020416	R412020460	R412020504
320	R412020417	R412020461	R412020505
400	R412020418	R412020462	R412020506
500	R412020419	R412020463	R412020507

Technical data

Piston Ø	16 mm	20 mm	25 mm
Retracting piston force	109 N	166 N	260 N
Extracting piston force	127 N	198 N	309 N
Cushioning length	11.5 mm	13 mm	14 mm
Cushioning energy	1 J	1.7 J	2.7 J
Impact energy	0.14 J	0.23 J	0.35 J
Weight 0 mm stroke	0.034 kg	0.063 kg	0.082 kg
Weight +10 mm stroke	0.002 kg	0.005 kg	0.006 kg
Stroke max.	800 mm	1100 mm	1200 mm

Technical information

The pressure dew point must be at least 15 °C under ambient and medium temperature and may not exceed 3 °C .

The oil content of compressed air must remain constant during the life cycle.

Use only the approved oils from AVENTICS. Further information can be found in the “Technical information” document (available in the MediaCentre).

Clamping piece for magnetic field sensor necessary

ATEX-certified cylinders with identification II 2G Ex h IIB T4 Gb / II 2D Ex h IIIB T135°C Db_X can be generated in the Internet configurator.

The operating temperature range for ATEX-certified cylinders is -20 °C ... 50 °C.

Technical information

Material	
Cylinder tube	Stainless steel
Piston rod	Stainless steel
Piston	Aluminum
Front cover	Stainless steel, Electropolished
End cover	Stainless steel, Electropolished
Seal	Nitrile butadiene rubber
Nut for cylinder mounting	Stainless steel
Nut for piston rod	Stainless steel
Scraper	Thermoplastic polyurethane (TPU)
Guide bushing	Plastic

Dimensions

Dimensions

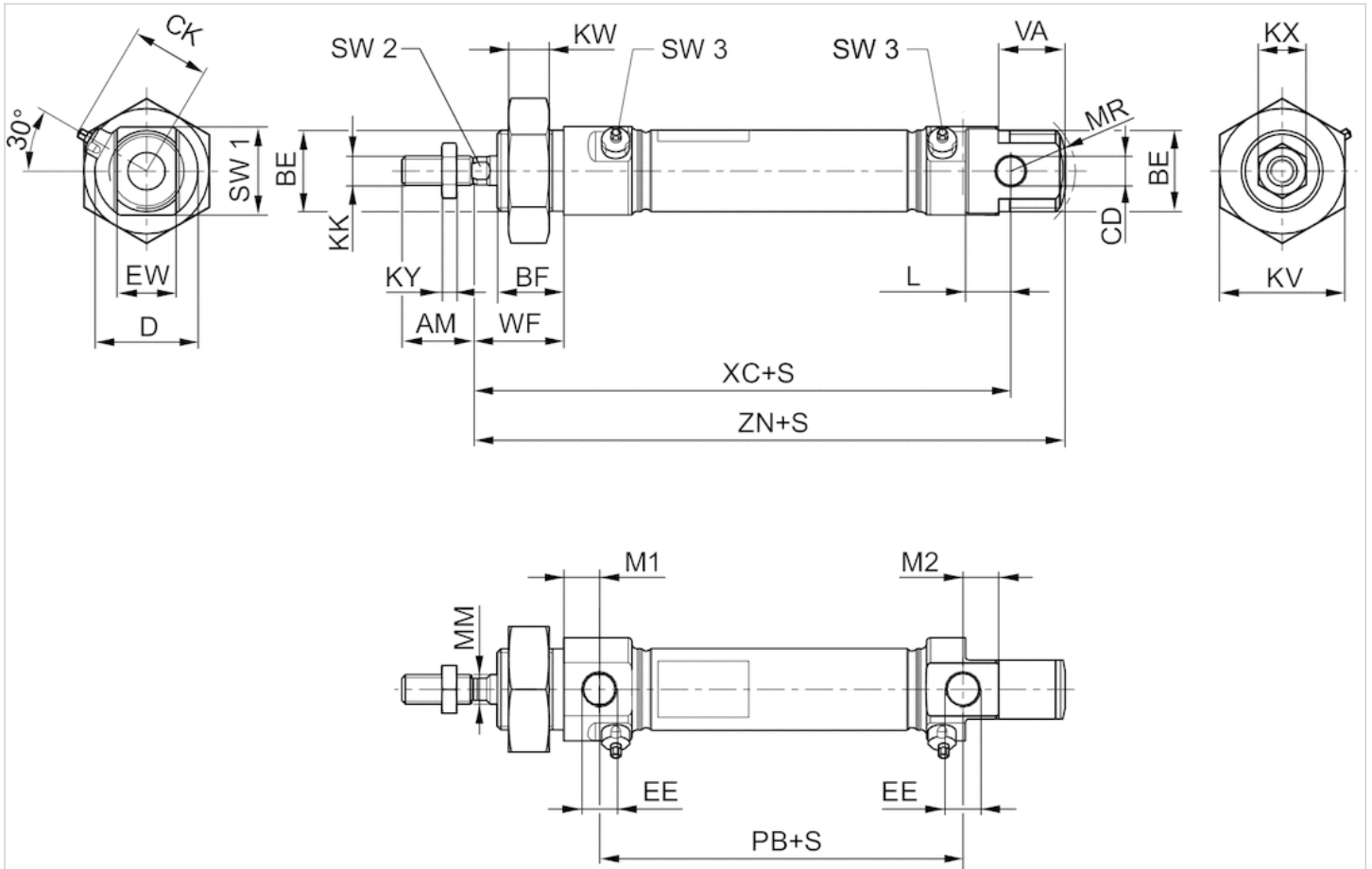

S = stroke

Dimensions

Piston Ø	AM-2	BE	BF	CD H9	CK max.	D	EE t = depth of thread	EW d13	KK
16 mm	16	M16x1,5	16	6	19.5	22	M5 t=5	12	M6
20 mm	20	M22x1,5	18	8	23	28	G 1/8 t=8	16	M8
25 mm	22	M22x1,5	20	8	25.5	33	G 1/8 t=8	16	M10x1,25

Piston Ø	KV	KW	KX	KY	L min.	M1/M2	MM f8	MR	PB ±1	VA	WF ±1,4	XC ±1	ZN ± 1	SW 1
16 mm	24	8	10	3.2	9	6.7	6	16	43.6	16	22	82	94.7	20
20 mm	34	11	13	4	12	9.7	8	18	48.6	18	24	95	109.7	24
25 mm	34	11	17	5	12	9.7	10	19	51.8	20	28	104	119.7	28

Piston Ø	SW 2 h13	SW 3
16 mm	5	2.5
20 mm	6	2.5
25 mm	8	2.5

Diagrams

Cushioning diagram

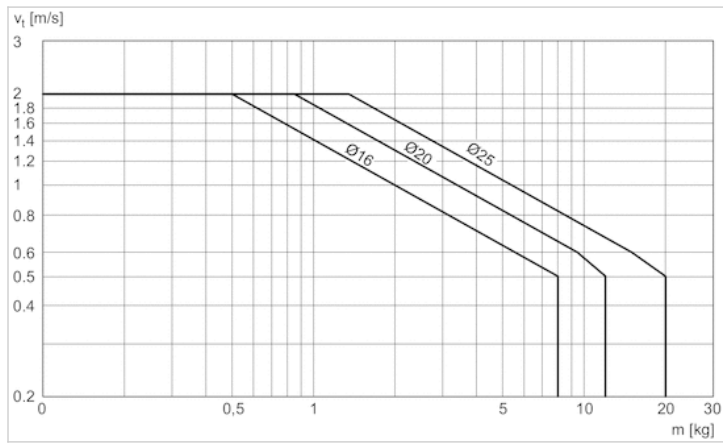

v = Piston velocity [m/s]

m = Cushionable mass [kg]

Accessories overview

Overview drawing

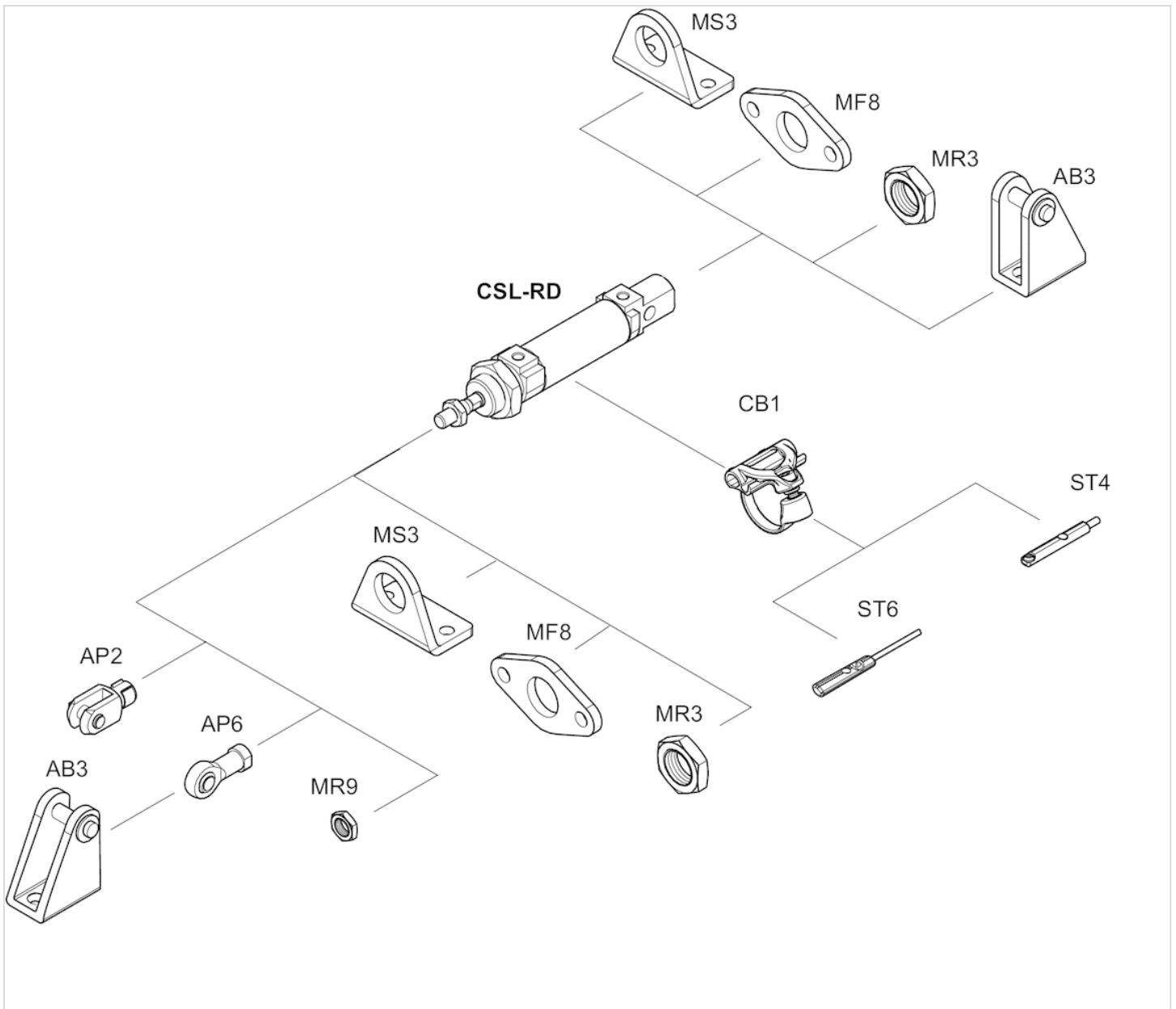

NOTE:

This overview drawing is only for orientation to indicate where the various accessory parts can be fastened to the cylinder. The illustration has been simplified for this purpose. It is thus not possible to derive the dimensions from this overview.

Mini cylinder, Series CSL-RD

- Version: hygienic design
- Ø 16-25 mm
- Ports M5 G 1/8
- double-acting
- with magnetic piston
- Cushioning pneumatically adjustable
- with integrated rear eye
- Piston rod External thread
- ATEX optional
- suitable for use in food processing



Standards	ISO 6432
Certificates	ATEX optional
Compressed air connection	Internal thread
Working pressure min./max.	1 ... 10 bar
Ambient temperature min./max.	-20 ... 80 °C
Medium temperature min./max.	-20 ... 80 °C
Medium	Compressed air
Max. particle size	50 µm
Oil content of compressed air	0 ... 5 mg/m ³
Pressure for determining piston forces	6.3 bar

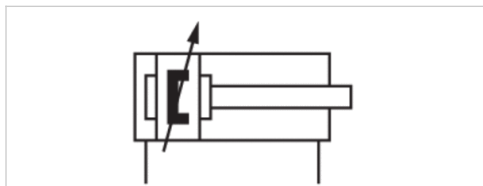

Technical data

Piston Ø Piston rod thread Ports Piston rod Ø	16 mm M6 M5 6 mm	20 mm M8 G 1/8 8 mm	25 mm M10x1,25 G 1/8 10 mm
Stroke 25	R412020431	R412020475	R412020519
50	R412020432	R412020476	R412020520
80	R412020433	R412020477	R412020521
100	R412020434	R412020478	R412020522
125	R412020435	R412020479	R412020523
160	R412020436	R412020480	R412020524
200	R412020437	R412020481	R412020525
250	R412020438	R412020482	R412020526
320	R412020439	R412020483	R412020527
400	R412020440	R412020484	R412020528
500	R412020441	R412020485	R412020529

Technical data

Piston Ø	16 mm	20 mm	25 mm
Retracting piston force	109 N	166 N	260 N
Extracting piston force	127 N	198 N	309 N
Cushioning length	11.5 mm	13 mm	14 mm
Cushioning energy	1 J	1.7 J	2.7 J
Impact energy	0.14 J	0.23 J	0.35 J
Weight 0 mm stroke	0.034 kg	0.063 kg	0.082 kg
Weight +10 mm stroke	0.002 kg	0.005 kg	0.006 kg
Stroke max.	800 mm	1100 mm	1200 mm

Technical information

The pressure dew point must be at least 15 °C under ambient and medium temperature and may not exceed 3 °C .

The oil content of compressed air must remain constant during the life cycle.

Use only the approved oils from AVENTICS. Further information can be found in the “Technical information” document (available in the MediaCentre).

Clamping piece for magnetic field sensor necessary

ATEX-certified cylinders with identification II 2G Ex h IIB T4 Gb / II 2D Ex h IIIB T135°C Db_X can be generated in the Internet configurator.

The operating temperature range for ATEX-certified cylinders is -20 °C ... 50 °C.

Technical information

Material	
Cylinder tube	Stainless steel
Piston rod	Stainless steel
Piston	Aluminum
Front cover	Stainless steel, Electropolished
End cover	Stainless steel, Electropolished
Seal	Nitrile butadiene rubber
Nut for cylinder mounting	Stainless steel
Nut for piston rod	Stainless steel
Scraper	Thermoplastic polyurethane (TPU)
Guide bushing	Plastic

Dimensions

Dimensions

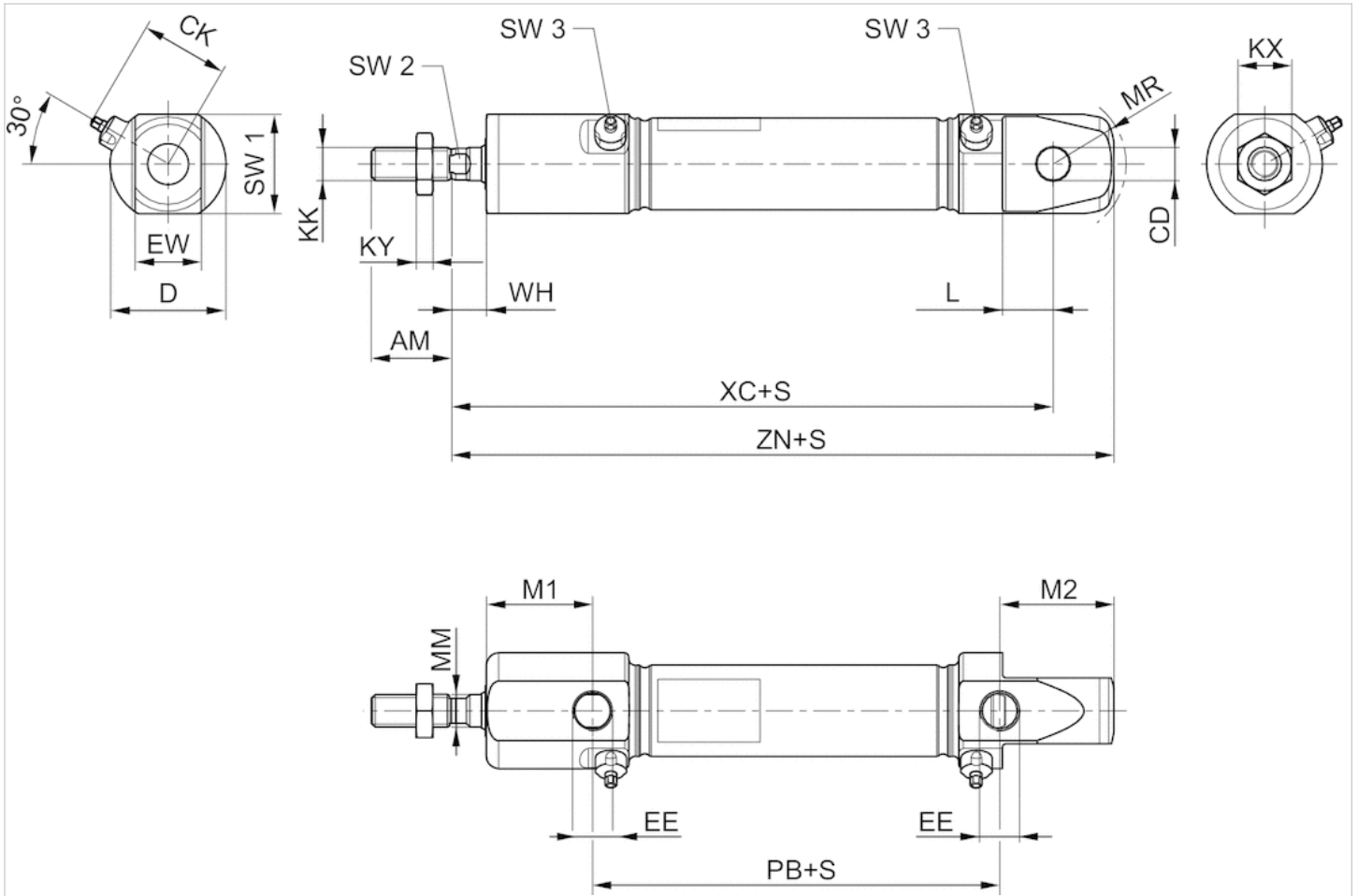

S = stroke

Dimensions

Piston Ø	AM-2	CD H9	CK max.	D	EE t = depth of thread	EW d13	KK	KX	KY
16 mm	16	6	19.5	22	M5 t=5	12	M6	10	3.2
20 mm	20	8	23	28	G 1/8 t=8	16	M8	13	4
25 mm	22	8	25.5	33	G 1/8 t=8	16	M10x1,25	17	5

Piston Ø	L min.	M1	M2	MM f8	MR	PB ±1	WH ±1,4	XC ±1	ZN ± 1	SW 1	SW 2 h13
16 mm	9	21.2	22.7	6	16	43.6	7.5	82	94.7	20	5
20 mm	12	25.7	27.7	8	18	48.6	8	95	109.7	24	6
25 mm	12	28.2	29.7	10	19	51.8	9.5	104	119.7	28	8

Piston Ø	SW 3
16 mm	2.5
20 mm	2.5
25 mm	2.5

Diagrams

Cushioning diagram

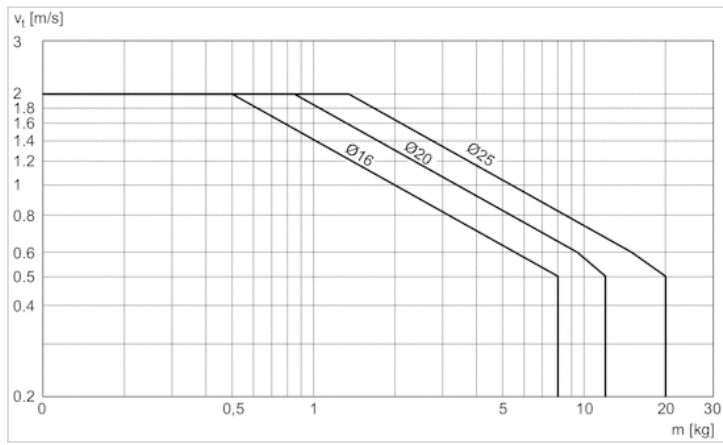

v = Piston velocity [m/s]

m = Cushionable mass [kg]

Accessories overview

Overview drawing

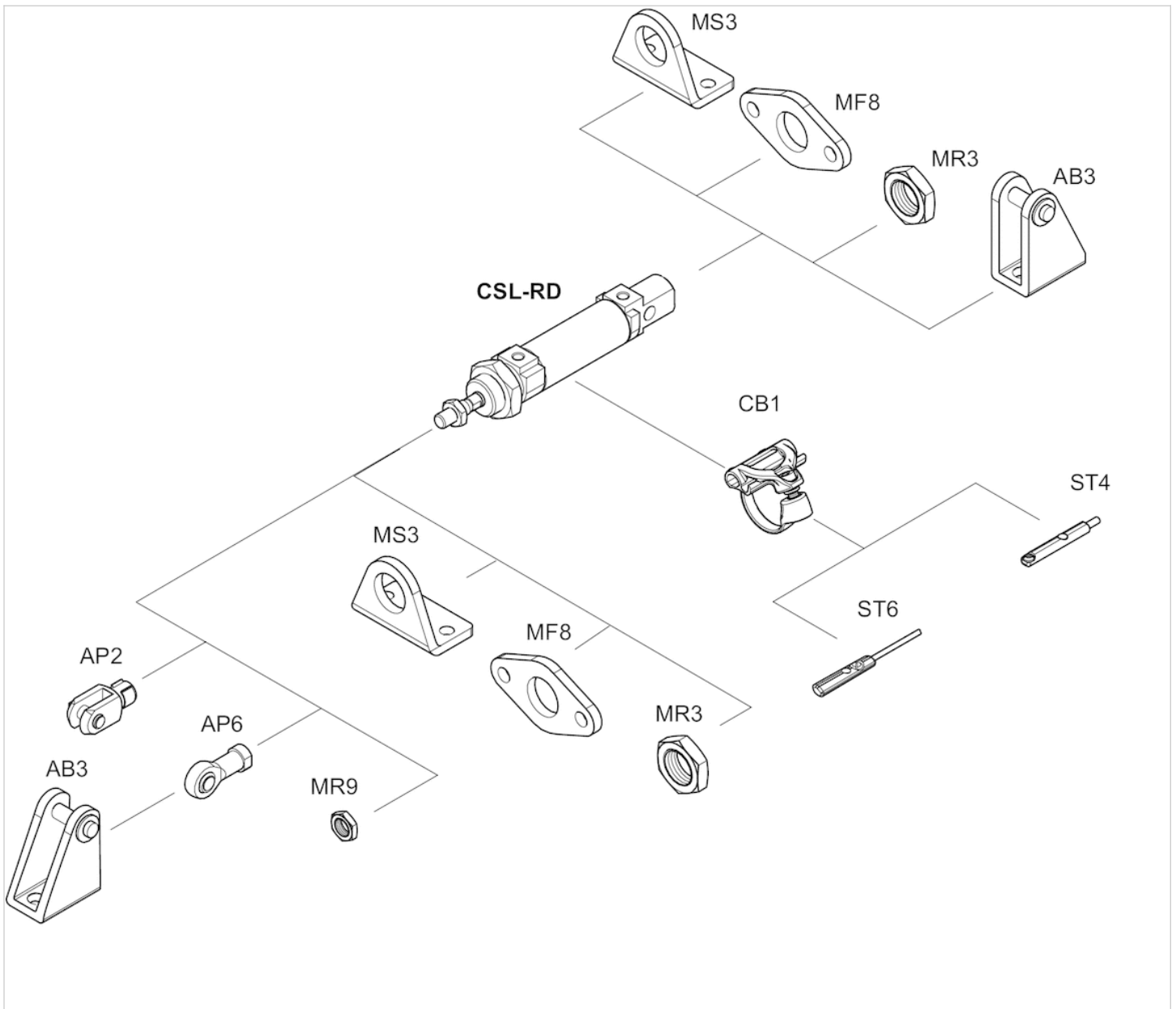

NOTE:

This overview drawing is only for orientation to indicate where the various accessory parts can be fastened to the cylinder. The illustration has been simplified for this purpose. It is thus not possible to derive the dimensions from this overview.

Mini cylinder, Series CSL-RD

- Version: ISO model
- Ø 16-25 mm
- Ports M5 G 1/8
- double-acting
- with magnetic piston
- Cushioning pneumatically non-adjustable
- with integrated rear eye
- Piston rod External thread
- ATEX optional
- suitable for use in food processing



Standards	ISO 6432
Certificates	ATEX optional
Compressed air connection	Internal thread
Working pressure min./max.	1 ... 10 bar
Ambient temperature min./max.	-20 ... 80 °C
Medium temperature min./max.	-20 ... 80 °C
Medium	Compressed air
Max. particle size	50 µm
Oil content of compressed air	0 ... 5 mg/m ³
Pressure for determining piston forces	6.3 bar

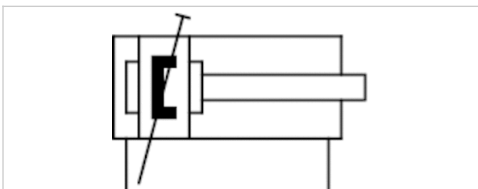

Technical data

Piston Ø Piston rod thread Ports Piston rod Ø	16 mm M6 M5 6 mm	20 mm M8 G 1/8 8 mm	25 mm M10x1,25 G 1/8 10 mm
Stroke 25	R480651366	R480651377	R480651388
50	R480651367	R480651378	R480651389
80	R480651368	R480651379	R480651390
100	R480651369	R480651380	R480651391
125	R480651370	R480651381	R480651392
160	R480651371	R480651382	R480651393
200	R480651372	R480651383	R480651394
250	R480651373	R480651384	R480651395
320	R480651374	R480651385	R480651396
400	R480651375	R480651386	R480651397
500	R480651376	R480651387	R480651398

Technical data

Piston Ø	16 mm	20 mm	25 mm
Retracting piston force	109 N	166 N	260 N
Extracting piston force	127 N	198 N	309 N
Cushioning length	11.5 mm	13 mm	14 mm
Cushioning energy	0.75 J	1.3 J	1.9 J
Impact energy	0.14 J	0.23 J	0.35 J
Weight 0 mm stroke	0.034 kg	0.063 kg	0.082 kg
Weight +10 mm stroke	0.002 kg	0.005 kg	0.006 kg
Stroke max.	800 mm	1100 mm	1200 mm

Technical information

The pressure dew point must be at least 15 °C under ambient and medium temperature and may not exceed 3 °C .

The oil content of compressed air must remain constant during the life cycle.

Use only the approved oils from AVENTICS. Further information can be found in the “Technical information” document (available in the MediaCentre).

Clamping piece for magnetic field sensor necessary

ATEX-certified cylinders with identification II 2G Ex h IIB T4 Gb / II 2D Ex h IIIB T135°C Db_X can be generated in the Internet configurator.

The operating temperature range for ATEX-certified cylinders is -20 °C ... 50 °C.

Technical information

Material	
Cylinder tube	Stainless steel, ground
Piston rod	Stainless steel, ground
Piston	Aluminum
Front cover	Stainless steel, Electropolished
End cover	Stainless steel, Electropolished
Seal	Nitrile butadiene rubber
Nut for cylinder mounting	Stainless steel, ground
Nut for piston rod	Stainless steel, ground
Scraper	Thermoplastic polyurethane (TPU)
Guide bushing	Steel

Dimensions

Dimensions

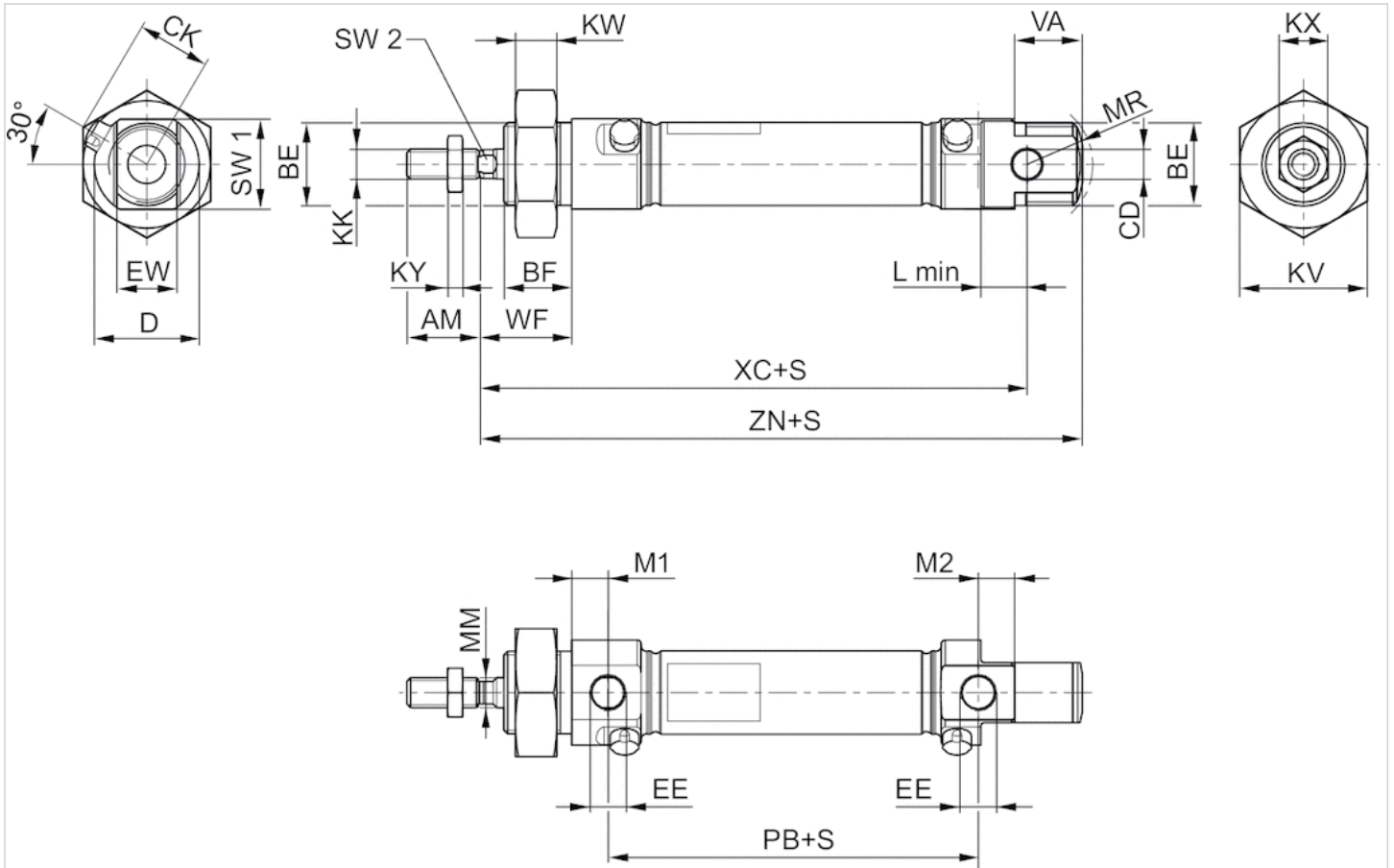

S = stroke

Dimensions

Piston Ø	AM-2	BE	BF	CD H9	CK	D	EE t = depth of thread	EW d13	KK	KV	KW
16 mm	16	M16x1,5	16	6	14.7	22	M5 t=5	12	M6	24	8
20 mm	20	M22x1,5	18	8	17.9	28	G 1/8 t=8	16	M8	32	11
25 mm	22	M22x1,5	20	8	20.2	33	G 1/8 t=8	16	M10x1,25	32	11

Piston Ø	KX	KY	L min	M1	M2	MM f8	MR	PB ±1	VA	WF ±1,4	XC ±1	ZN ± 1	SW 1	SW 2
16 mm	10	3.2	9	6.7	6.7	6	16	43.6	16	22	82	94.7	20	5
20 mm	13	4	12	9.7	9.7	8	18	48.6	18	24	95	109.7	24	6
25 mm	17	5	12	9.7	9.7	10	19	52.6	20	28	104	119.7	28	8

Diagrams

Cushioning diagram

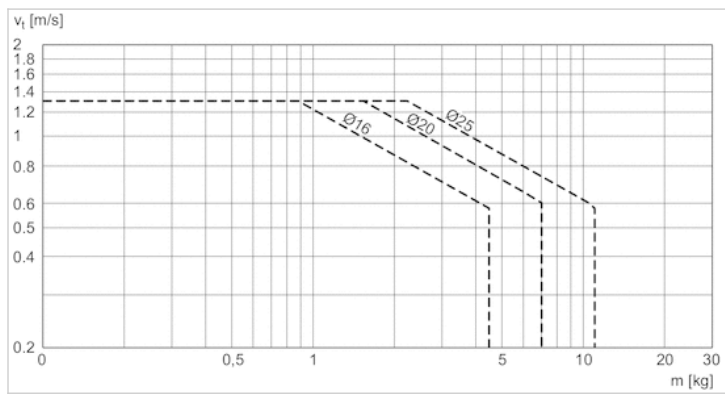

v = Piston velocity [m/s]

m = Cushionable mass [kg]

Accessories overview

Overview drawing

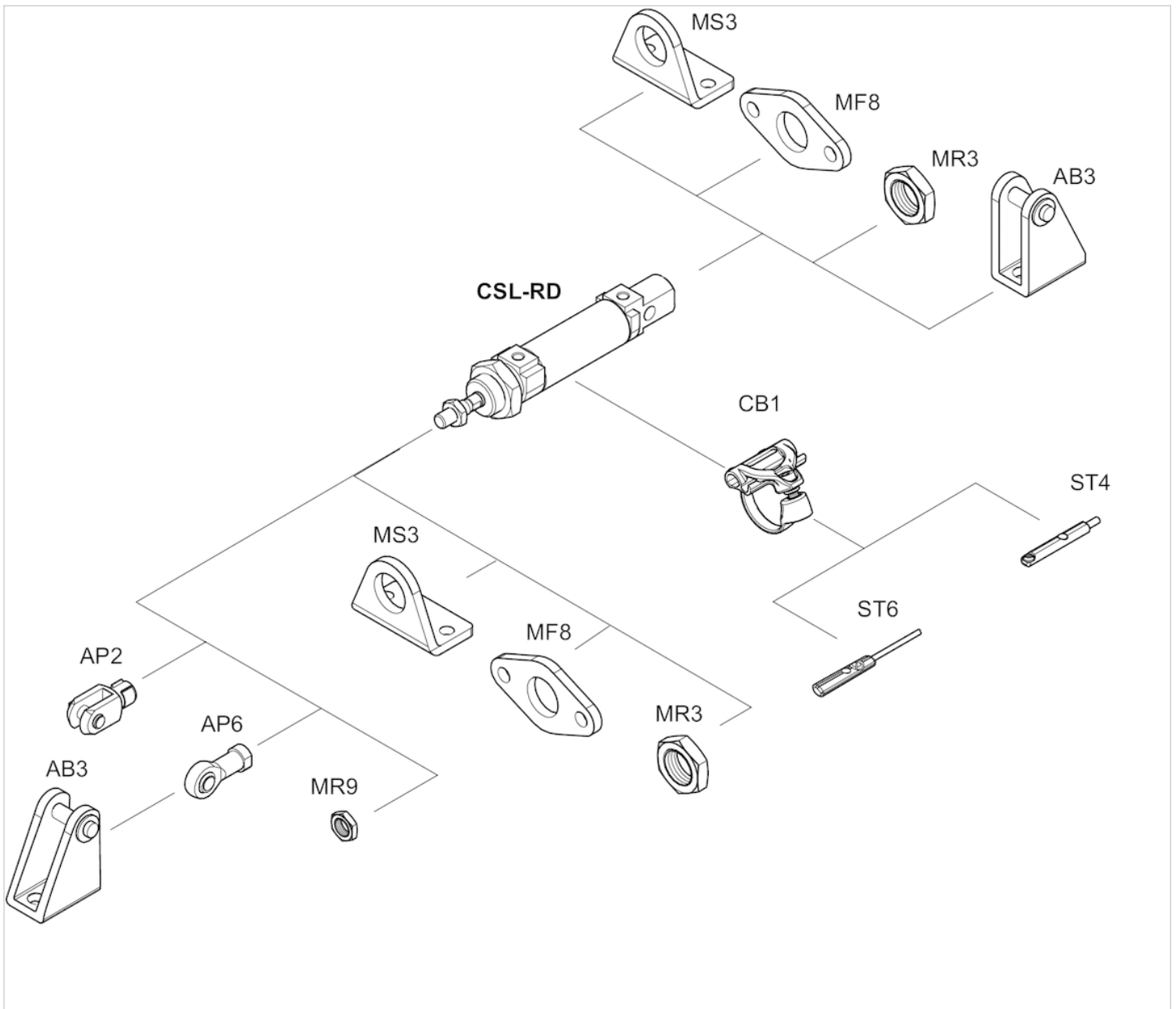

NOTE:

This overview drawing is only for orientation to indicate where the various accessory parts can be fastened to the cylinder. The illustration has been simplified for this purpose. It is thus not possible to derive the dimensions from this overview.

Mini cylinder, Series CSL-RD

- Version: hygienic design
- Ø 16-25 mm
- Ports M5 G 1/8
- double-acting
- with magnetic piston
- Cushioning pneumatically non-adjustable
- with integrated rear eye
- Piston rod External thread
- ATEX optional
- suitable for use in food processing



Standards	ISO 6432
Certificates	ATEX optional
Compressed air connection	Internal thread
Working pressure min./max.	1 ... 10 bar
Ambient temperature min./max.	-20 ... 80 °C
Medium temperature min./max.	-20 ... 80 °C
Medium	Compressed air
Max. particle size	50 µm
Oil content of compressed air	0 ... 5 mg/m ³
Pressure for determining piston forces	6.3 bar

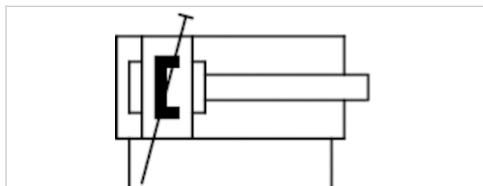

Technical data

Piston Ø Piston rod thread Ports Piston rod Ø	16 mm M6 M5 6 mm	20 mm M8 G 1/8 8 mm	25 mm M10x1,25 G 1/8 10 mm
Stroke 25	R480651399	R480651410	R480651421
50	R480651400	R480651411	R480651422
80	R480651401	R480651412	R480651423
100	R480651402	R480651413	R480651424
125	R480651403	R480651414	R480651425
160	R480651404	R480651415	R480651426
200	R480651405	R480651416	R480651427
250	R480651406	R480651417	R480651428
320	R480651407	R480651418	R480651429
400	R480651408	R480651419	R480651430
500	R480651409	R480651420	R480651431

Technical data

Piston Ø	16 mm	20 mm	25 mm
Retracting piston force	109 N	166 N	260 N
Extracting piston force	127 N	198 N	309 N
Cushioning length	11.5 mm	13 mm	14 mm
Cushioning energy	0.75 J	1.3 J	1.9 J
Impact energy	0.14 J	0.23 J	0.35 J
Weight 0 mm stroke	0.034 kg	0.063 kg	0.082 kg
Weight +10 mm stroke	0.002 kg	0.005 kg	0.006 kg
Stroke max.	800 mm	1100 mm	1300 mm

Technical information

The pressure dew point must be at least 15 °C under ambient and medium temperature and may not exceed 3 °C .

The oil content of compressed air must remain constant during the life cycle.

Use only the approved oils from AVENTICS. Further information can be found in the "Technical information" document (available in the MediaCentre).

Clamping piece for magnetic field sensor necessary

ATEX-certified cylinders with identification II 2G Ex h IIB T4 Gb / II 2D Ex h IIIB T135°C Db_X can be generated in the Internet configurator.

The operating temperature range for ATEX-certified cylinders is -20 °C ... 50 °C.

Technical information

Material	
Cylinder tube	Stainless steel, ground
Piston rod	Stainless steel, ground
Piston	Aluminum
Front cover	Stainless steel, Electropolished
End cover	Stainless steel, Electropolished
Seal	Nitrile butadiene rubber
Nut for cylinder mounting	Stainless steel, ground
Nut for piston rod	Stainless steel, ground
Scraper	Thermoplastic polyurethane (TPU)
Guide bushing	Steel

Dimensions

Dimensions

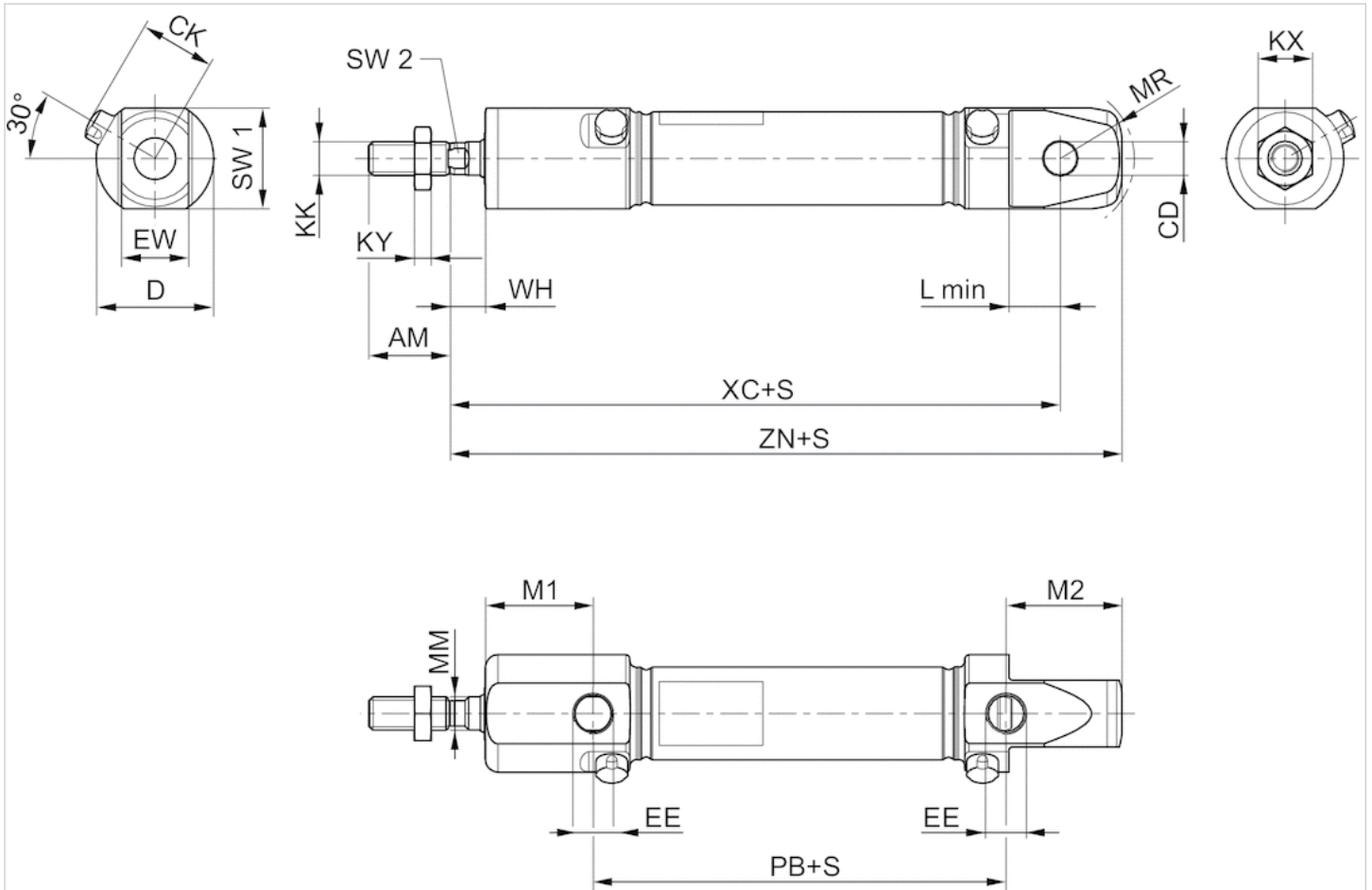

S = stroke

Dimensions

Piston Ø	AM-2	CD H9	CK	D	EE t = depth of thread	EW d13	KK	KX	KY	L min	M1
16 mm	16	6	14.7	22	M5 t=5	12	M6	10	3.2	9	21.2
20 mm	20	8	17.9	28	G 1/8 t=8	16	M8	13	4	12	25.7
25 mm	22	8	20.2	33	G 1/8 t=8	16	M10x1,25	17	5	12	28.2

Piston Ø	M2	MM f8	MR	PB ±1	WH ±1,2	XC ±1	ZN ± 1	SW 1	SW 2
16 mm	22.7	6	16	43.6	7.5	82	94.7	20	5
20 mm	27.7	8	18	48.6	8	95	109.7	24	6
25 mm	29.7	10	19	51.8	9.5	104	119.7	28	8

Diagrams

Cushioning diagram

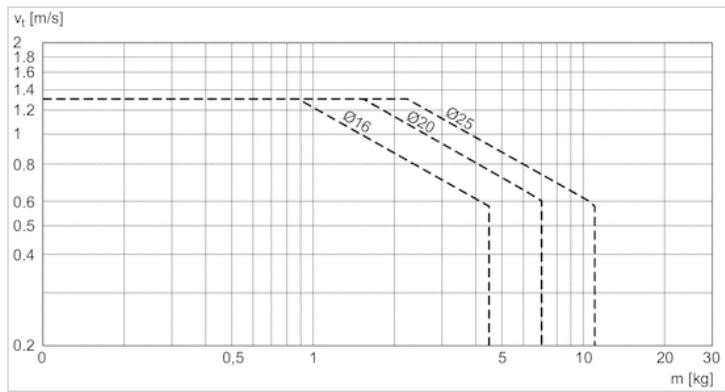

v = Piston velocity [m/s]

m = Cushionable mass [kg]

Accessories overview

Overview drawing

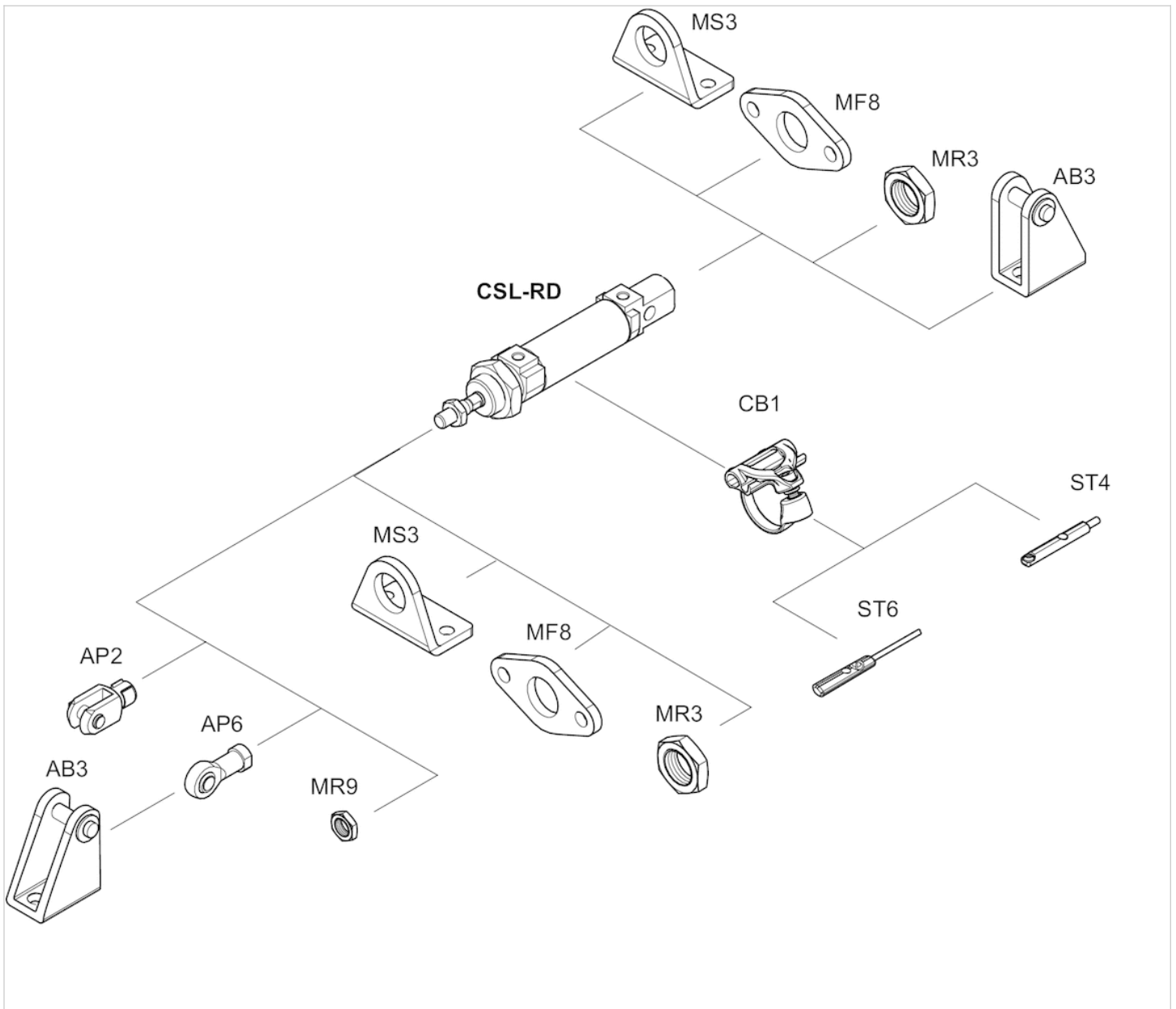

NOTE:

This overview drawing is only for orientation to indicate where the various accessory parts can be fastened to the cylinder. The illustration has been simplified for this purpose. It is thus not possible to derive the dimensions from this overview.

Mini cylinder, Series CSL-RD

- Version: Heat-resistant
- Ø 16-25 mm
- Ports M5 G 1/8
- double-acting
- with magnetic piston
- Cushioning elastic non-adjustable
- with integrated rear eye
- Piston rod External thread
- suitable for use in food processing



Standards	ISO 6432
Compressed air connection	Internal thread
Working pressure min./max.	1 ... 10 bar
Ambient temperature min./max.	-10 ... 120 °C
Medium temperature min./max.	-10 ... 120 °C
Medium	Compressed air
Max. particle size	50 µm
Oil content of compressed air	0 ... 5 mg/m ³
Pressure for determining piston forces	6.3 bar

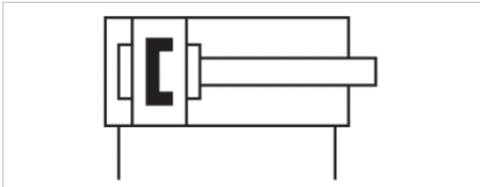

Technical data

Piston Ø Piston rod thread Ports Piston rod Ø	16 mm M6 M5 6 mm	20 mm M8 G 1/8 8 mm	25 mm M10x1,25 G 1/8 10 mm
Stroke 25	R480646359	R480646370	R480646381
50	R480646360	R480646371	R480646382
80	R480646361	R480646372	R480646383
100	R480646362	R480646373	R480646384
125	R480646363	R480646374	R480646385
160	R480646364	R480646375	R480646386
200	R480646365	R480646376	R480646387
250	R480646366	R480646377	R480646388
320	R480646367	R480646378	R480646389
400	R480646368	R480646379	R480646390
500	R480646369	R480646380	R480646391

Technical data

Piston Ø	16 mm	20 mm	25 mm
Retracting piston force	109 N	166 N	260 N
Extracting piston force	127 N	198 N	309 N
Impact energy	0.14 J	0.23 J	0.35 J
Weight 0 mm stroke	0.034 kg	0.063 kg	0.082 kg
Weight +10 mm stroke	0.002 kg	0.005 kg	0.006 kg
Stroke max.	800 mm	1100 mm	1200 mm

Technical information

The pressure dew point must be at least 15 °C under ambient and medium temperature and may not exceed 3 °C .

The oil content of compressed air must remain constant during the life cycle.

Use only the approved oils from AVENTICS. Further information can be found in the "Technical information" document (available in the MediaCentre).

Clamping piece for magnetic field sensor necessary

Ambient temperature with contact query max. 120 °C

Technical information

Material	
Cylinder tube	Stainless steel
Piston rod	Stainless steel
Piston	Aluminum
Front cover	Stainless steel, Electropolished
End cover	Stainless steel, Electropolished
Seal	Fluorocaoutchouc
Nut for cylinder mounting	Stainless steel
Nut for piston rod	Stainless steel
Scraper	Fluorocaoutchouc
Guide bushing	Plastic

Dimensions

Dimensions

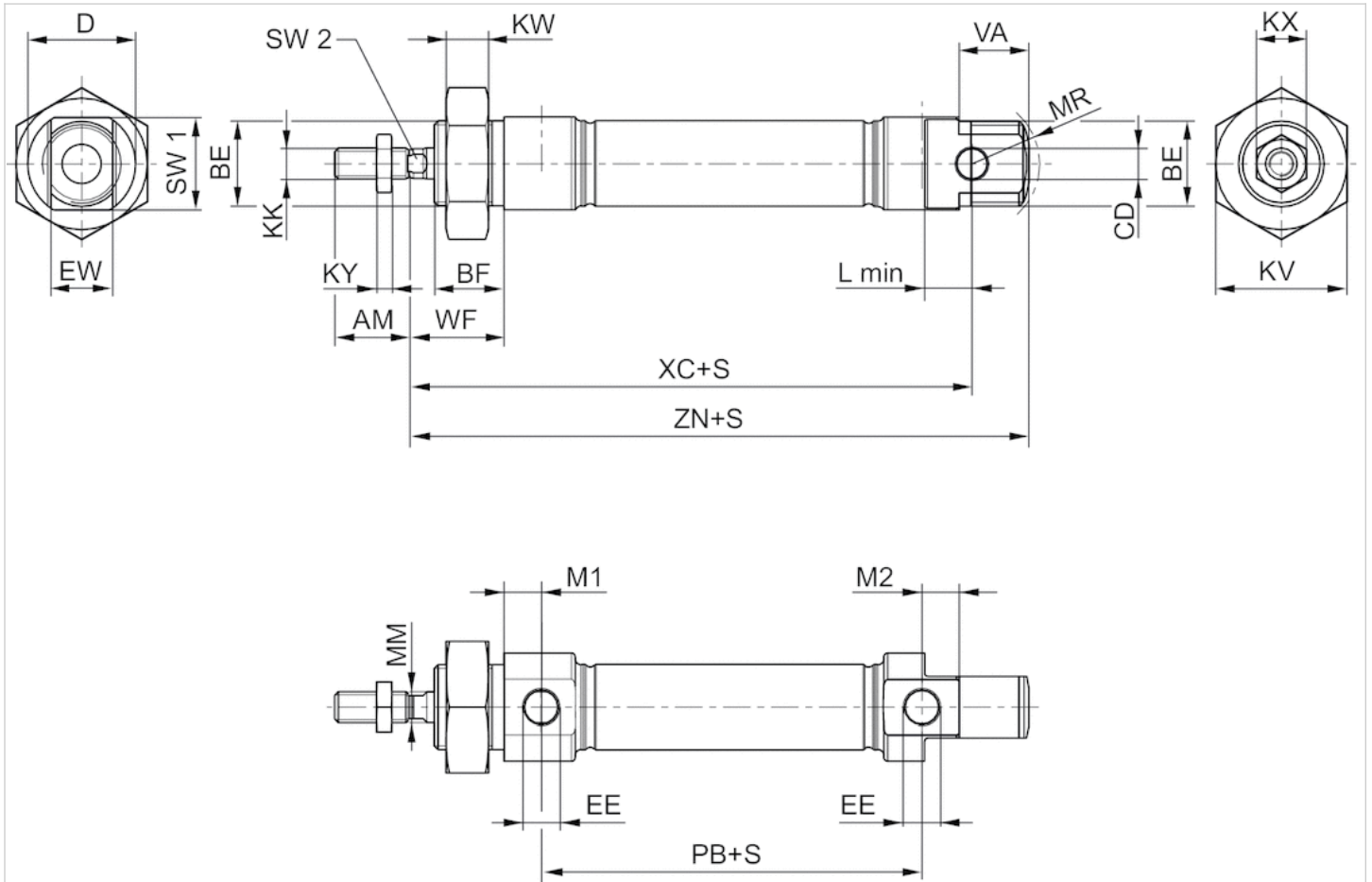

S = stroke

Dimensions

Piston Ø	AM-2	BE	BF	CD H9	D	EE t = depth of thread	EW d13	KK	KV	KW	KX
16 mm	16	M16x1,5	16	6	22	M5 t=5	12	M6	24	8	10
20 mm	20	M22x1,5	18	8	28	G 1/8 t=8	16	M8	32	11	13
25 mm	22	M22x1,5	20	8	33	G 1/8 t=8	16	M10x1,25	32	11	17

Piston Ø	KY	L min	M1/M2	MM f8	MR	PB ±1	VA	WF ±1,4	XC ±1	ZN ±1	SW 1	SW 2
16 mm	3.2	9	6.7	6	16	43.6	16	22	82	94.7	20	5
20 mm	4	12	9.7	8	18	48.6	18	24	95	109.7	24	6
25 mm	5	12	9.7	10	19	52.6	20	28	104	119.7	28	8

Accessories overview

Overview drawing

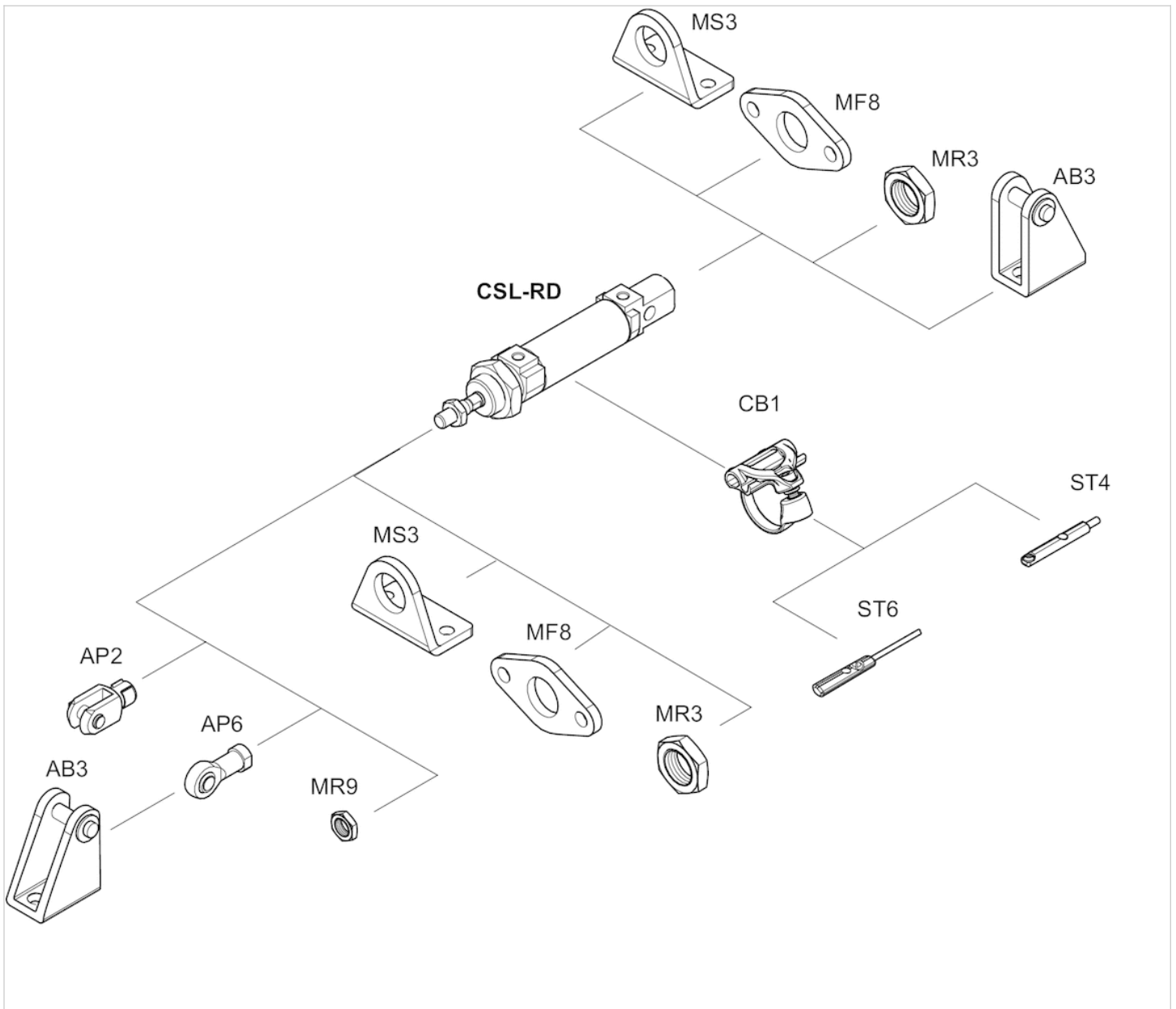

NOTE:

This overview drawing is only for orientation to indicate where the various accessory parts can be fastened to the cylinder. The illustration has been simplified for this purpose. It is thus not possible to derive the dimensions from this overview.

Clevis mounting AB3, Series CM1

- Suitable piston Ø 12, 16 20, 25 mm



The delivered product may vary from that in the illustration.

Technical data

Part No.	Piston Ø	Swivel bearing Ø	Fig.
3323416000	12, 16 mm	6 mm	Fig. 2
3323420000	20, 25 mm	8 mm	Fig. 2

Scope of delivery: clevis mounting incl. pivot pins

Technical information

Material	
Material	Stainless steel

Dimensions

Fig. 1

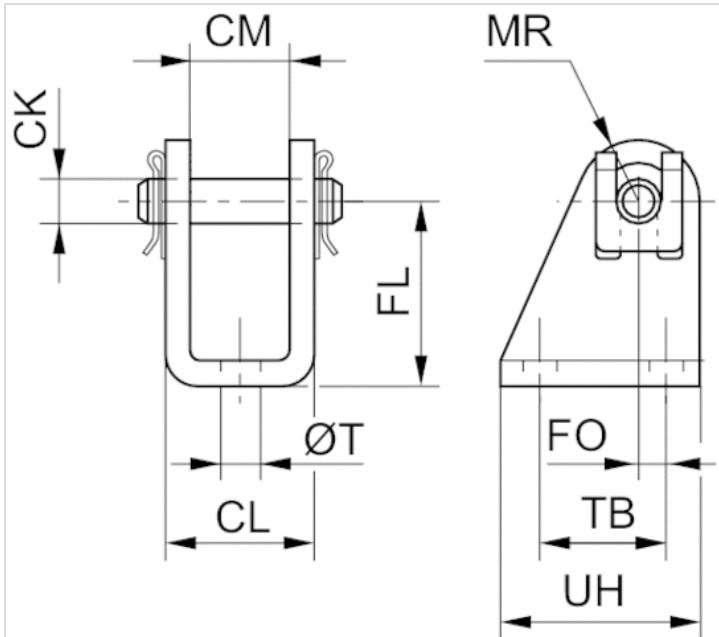
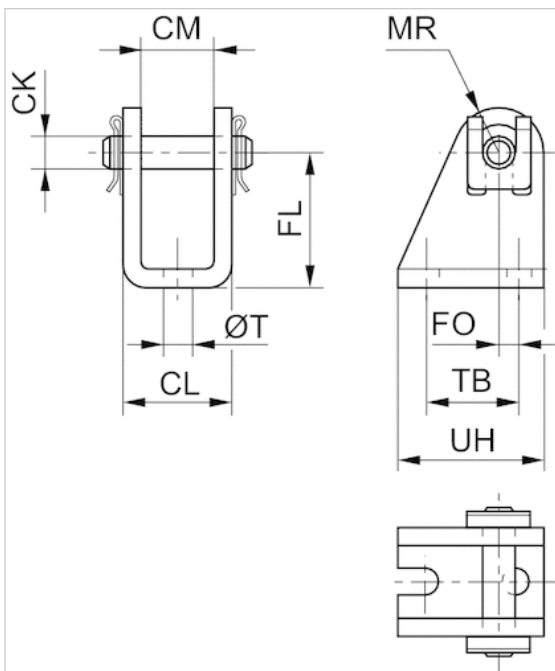

Fig. 2



Dimensions

Part No.	Piston Ø	Fig.	CM	Ø CK	CL	FL	FO	MR	Ø T	TB	UH
3323416000	12, 16 mm	Fig. 2	12	6	18	27	2,0	7	5.5	15	25
3323420000	20, 25 mm	Fig. 2	16	8	24	30	4,0	10	6.6	22	34

Flange mounting MF8, Series CM1

- Cylinder mounting in accordance with ISO 6432

- Suitable piston \varnothing 12, 16 20, 25 mm



Standards

ISO 6432

Technical data

Part No.	Piston \varnothing
3322016000	12, 16 mm
3322020000	20, 25 mm

Technical information

Material	
Material	Stainless steel

Dimensions

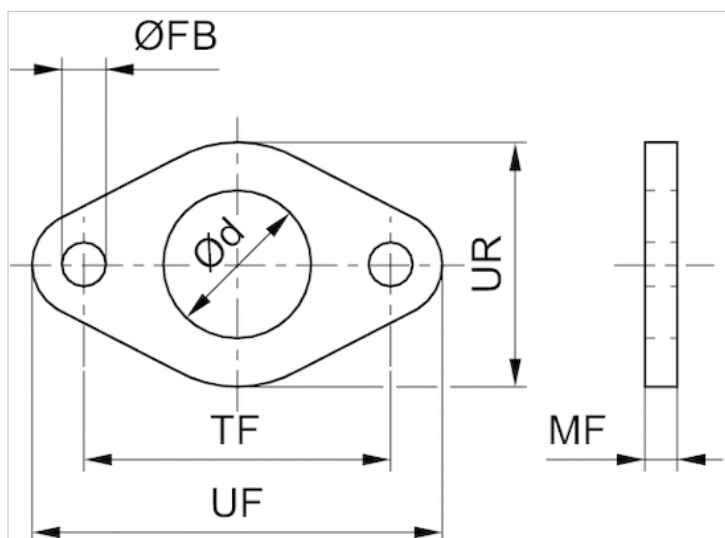

Dimensions

Part No.	Piston Ø	Ø d	Ø FB	MF	TF js14	UF	UR
3322016000	12, 16 mm	16	5.5	4	40	52	30
3322020000	20, 25 mm	22	6.6	5	50	66	40

Foot mounting MS3, Series CM1

- Cylinder mounting in accordance with ISO 6432

- Suitable piston Ø 12, 16 20, 25 mm



Standards

ISO 6432

Technical data

Part No.	Piston Ø
3322216000	12, 16 mm
3322220000	20, 25 mm

Technical information

Material	
Material	Stainless steel

Dimensions

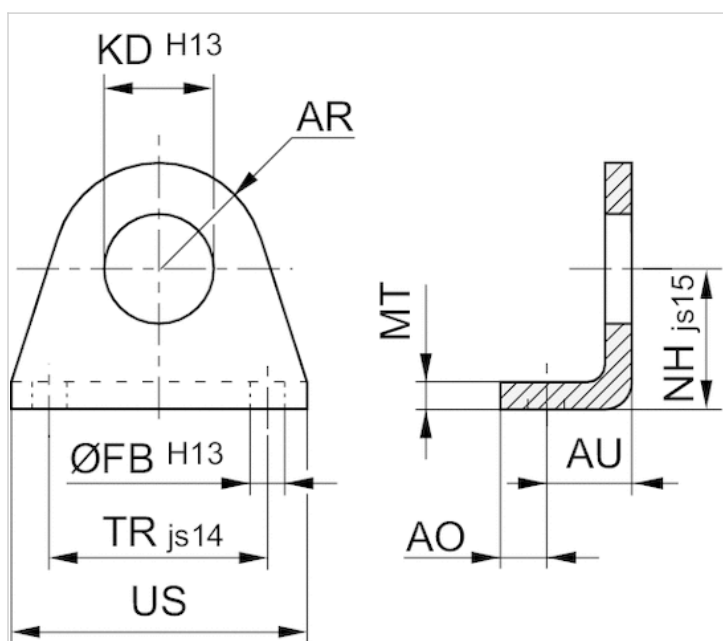

Dimensions

Part No.	Piston \varnothing	AO	AR	AU	\varnothing FB H13	\varnothing KD H13	MT	NH $\pm 0,3$ js15	TR js14	US
3322216000	12, 16 mm	6	12.5	14	5.5	16.1	4	20	32	42
3322220000	20, 25 mm	8	20	17.5	6.6	22.1	5	25	40	54

Nut MR3, series CM1

- for cylinder mounting
- Suitable piston \varnothing 16 20, 25 mm
- for series CSL-RD



Weight

See table below

Technical data

Part No.	Piston \varnothing	Thread size	Weight
2918540030	16 mm	M16x1,5	0.02 kg
R913030290	20, 25 mm	M22x1,5	0.05 kg

Technical information

Material	
Material	Stainless steel

Dimensions

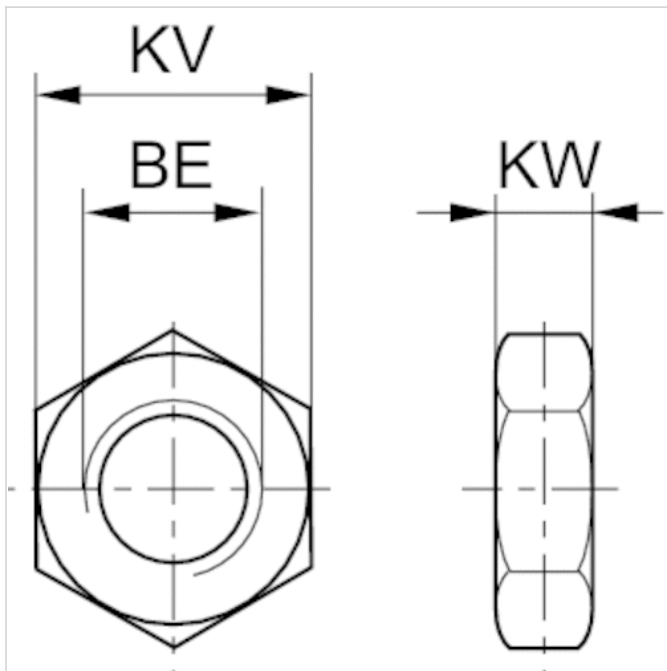

Dimensions

Part No.	Piston Ø	For series	BE	KV	KW
2918540030	16 mm	CSL-RD	M16 x1,5	27	8
R913030290	20, 25 mm	CSL-RD	M22 x1,5	32	11

Piston rod nut MR9



Weight

See table below

Technical data

Part No.	Suitable piston rod thread	Weight
8103190644	M6	0.003 kg
8103190164	M8	0.006 kg
8103190464	M10x1,25	0.008 kg

Technical information

Material	
	Stainless steel

Dimensions

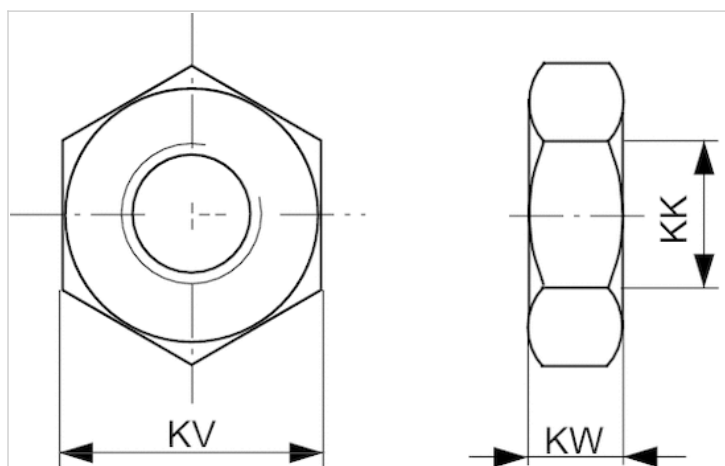

Dimensions

Part No.	KK	KV	KW
8103190644	M6	10	3.2
8103190164	M8	13	4
8103190464	M10x1,25	17	5

Rod clevis AP2, Series CM2

- with circlip, to mount on cylinder CCL-IS/IC, CCI, SSI, CSL-RD, ICM, ICS-D2, 167



Weight

See table below

Technical data

Part No.	Suitable piston rod thread	for	Weight
3330516000	M6	CSL-RD SSI ICM	0.02 kg
3330520000	M8	CCL-IC CSL-RD CCI ICM	0.05 kg
3590502000	M10x1,25	CCL-IS CCL-IC CCI CSL-RD SSI ICM ICS-D2 167	0.1 kg

Technical information

Material

Stainless steel

Dimensions

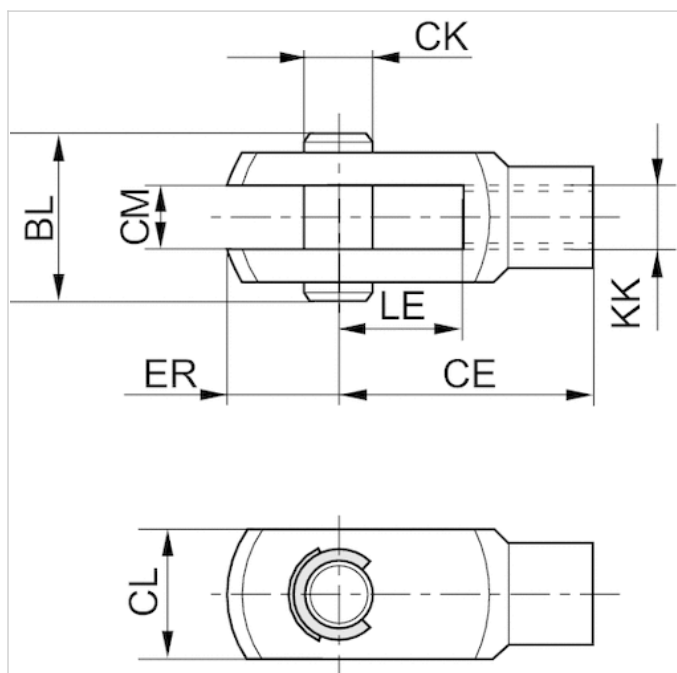

Dimensions

Part No.	KK	CE	CK e8	CL	CM B12	ER	BL	LE
3330516000	M6	24	6	12	6	7	17	12
3330520000	M8	32	8	16	8	10	22	16
3590502000	M10x1,25	40	10	20	10	12	26	20

Ball eye rod end AP6, series CM2

- with flange, to mount on cylinder CCL-IS/IC, SSI, CSL-RD, ICM, ICS-D2



Weight

See table below

Technical data

Part No.	Suitable piston rod thread	for	Swivel bearing Ø	Weight
8958209012	M6	CCL-IC CSL-RD ICM	152.4 mm	0.04 kg
8958209022	M8	CCL-IC CSL-RD ICM	203.2 mm	0.06 kg
8958209032	M10x1,25	CCL-IS CCL-IC SSI CSL-RD ICM ICS-D2	254 mm	0.09 kg

Technical information

Material
Stainless steel

Dimensions

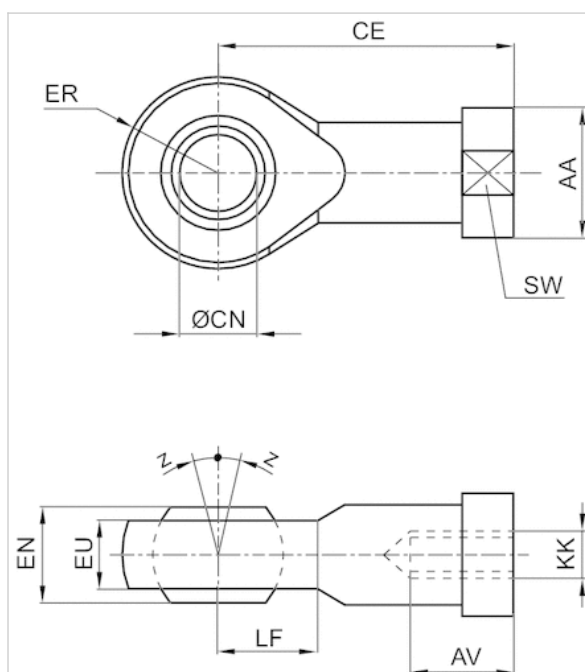

Dimensions

Part No.	KK	AA	AV min.	CE	$\varnothing CN H7$	EN -0,1	ER	EU max.	LF	SW	Z [°] max.
8958209012	M6	13	9	30	6	9	10	6,75	10	11	6,5
8958209022	M8	16	12	36	8	12	12	9	12	14	6,5
8958209032	M10x1,25	19	15	43	10	14	14	10.5	14	17	6,5

Check-choke valve, stainless steel, Series CC02-SL

- suitable for use in food processing
- $Q_n 2 \rightarrow 1 = 50-200 \text{ l/min}$
- direction of throttle $2 \rightarrow 1$
- exhaust air throttling
- push-in fitting / External thread
- Heat resistant



Certificates

Working pressure min./max.
Ambient temperature min./max.
Medium temperature min./max.
Medium

NSF/ANSI 169 FDA conform EU
Regulation 1935/2004

0.5 ... 10 bar
0 ... 150 °C
0 ... 150 °C
Compressed air

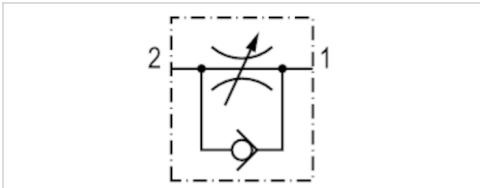

Technical data

Part No.	Port 1	Port 2	Flow	Delivery unit	Fig.
			$Q_n 2 \rightarrow 1$		
R412024736	Ø 4	M5	50 l/min	1 piece	Fig. 1
R412024737	Ø 4	G 1/8	150 l/min	1 piece	Fig. 2
R412024738	Ø 6	G 1/8	190 l/min	1 piece	Fig. 3
R412024739	Ø 8	G 1/8	200 l/min	1 piece	Fig. 4

Nominal flow Q_n at 6 bar and $\Delta p = 1 \text{ bar}$

Technical information

Materials according to AISI/FDA:

Housing ▶ Stainless steel AISI 316L (1.4404)

Flow control screw ▶ Stainless steel AISI 316L (1.4404)

Seal ▶ FKM (FDA-compliant)

Stainless steel connection ▶ AISI 316L (1.4404)

Technical information

Material	
Housing	Stainless steel
Flow control screw	Stainless steel
Seals	Fluorocaoutchouc

Dimensions

Dimensions

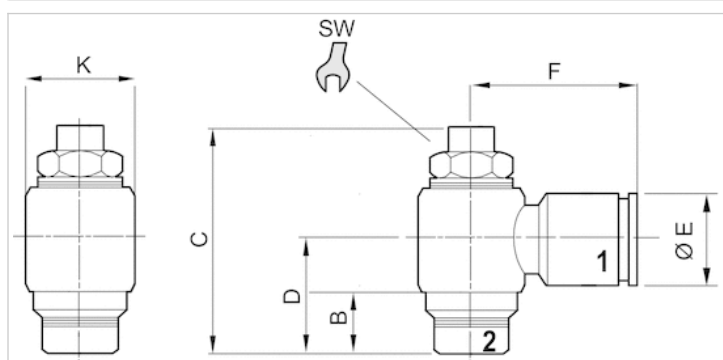

Dimensions

Part No.	Port 1	Port 2	B	C	D	ØE	F	ØK	SW
R412024736	Ø 4	M5	5	28.5	12.5	9	18	10	6
R412024737	Ø 4	G 1/8	5	32	15.5	9	19.5	14	9
R412024738	Ø 6	G 1/8	5	32	15.5	12	22	14	9
R412024739	Ø 8	G 1/8	5	32	15.5	14	22.5	14	9

Diagrams

Flow diagram, Fig. 1

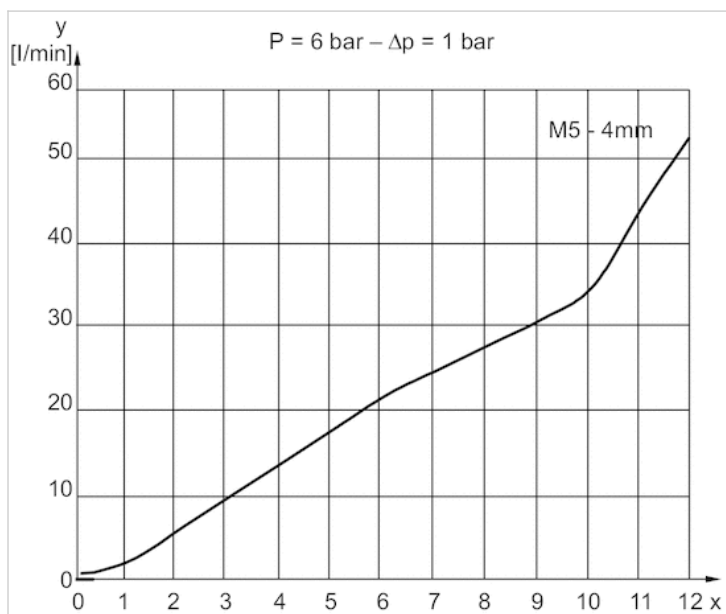

Flow diagram, Fig. 2

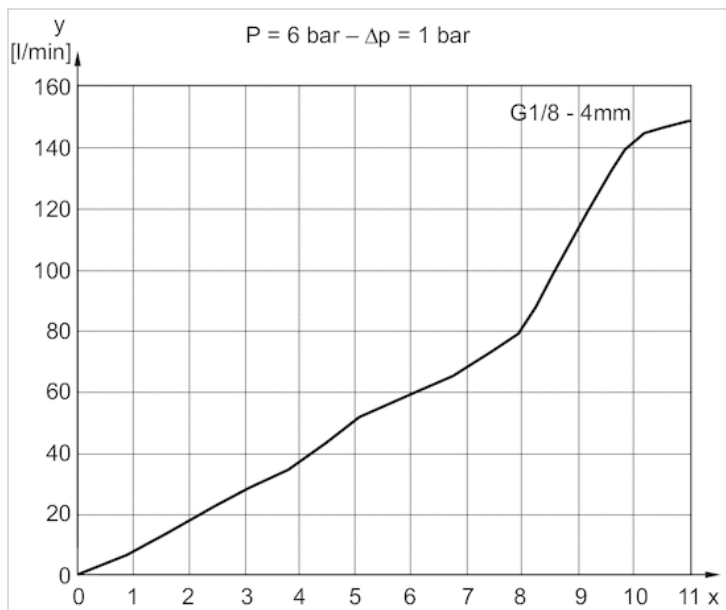

Flow diagram, Fig. 3

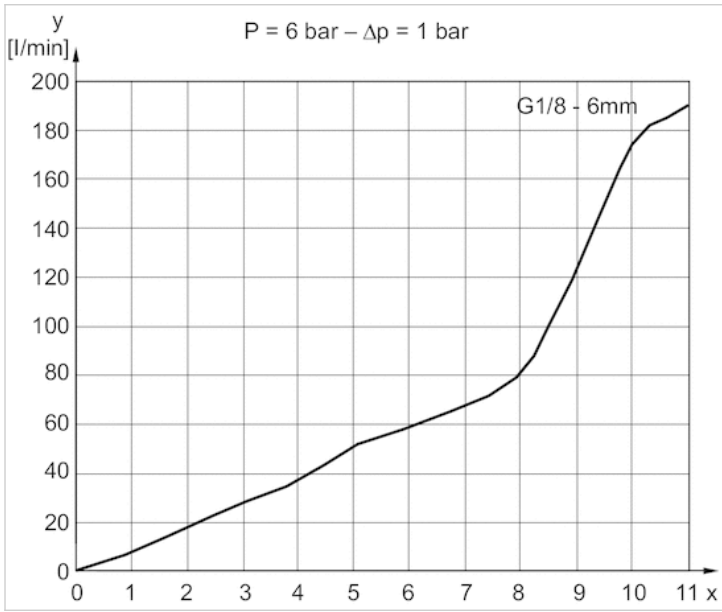

Flow diagram, Fig. 4

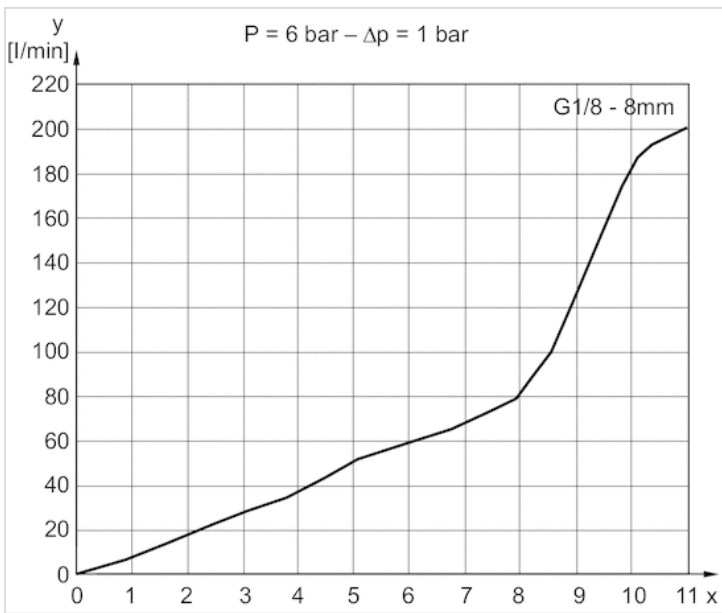

Flow diagram, Fig. 5

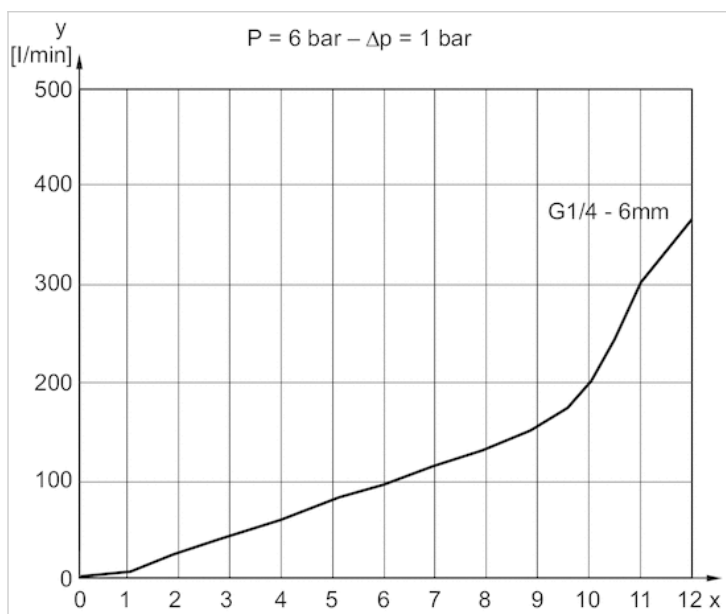

Flow diagram, Fig. 6

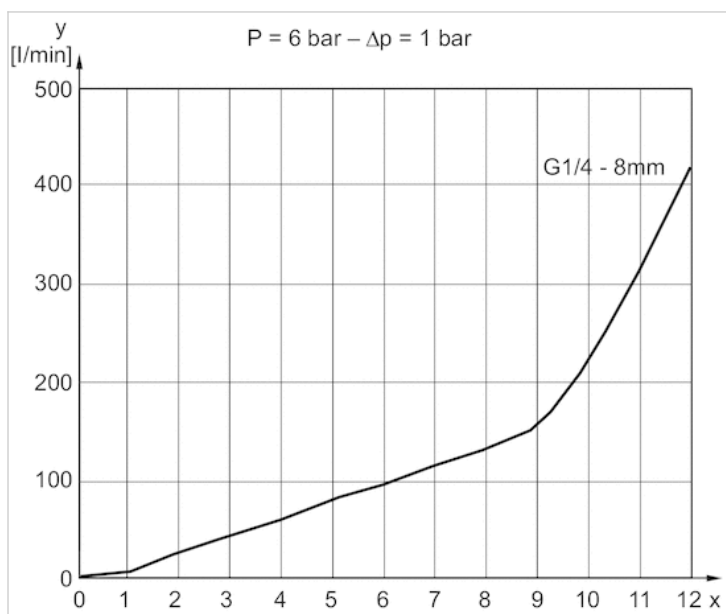

Flow diagram, Fig. 7

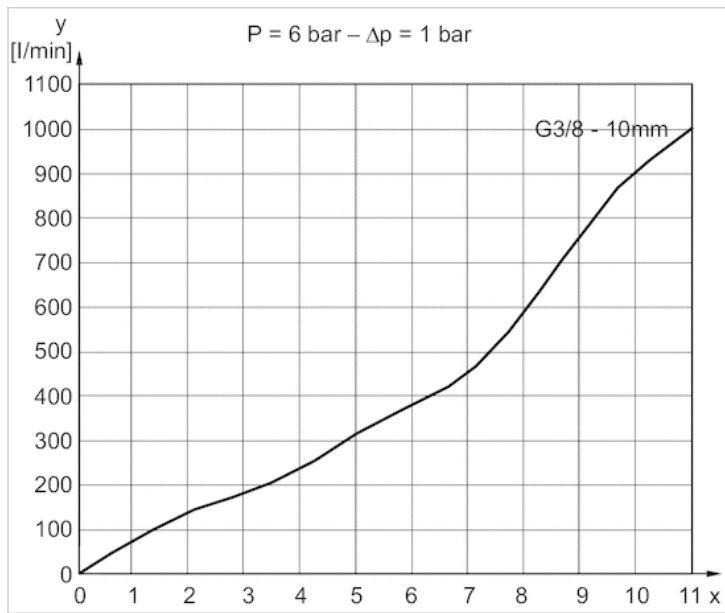

Check-choke valve, Series CC04

- $Q_n 2 \rightarrow 1 = 70\text{--}470 \text{ l/min}$
- direction of throttle $2 \rightarrow 1$
- exhaust air throttling
- push-in fitting / External thread



Working pressure min./max.	0.5 ... 10 bar
Ambient temperature min./max.	-10 ... 60 °C
Medium temperature min./max.	-10 ... 60 °C
Medium	Compressed air

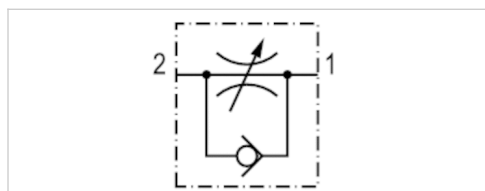

Technical data

Part No.	Port 1	Port 2	Throttle bore	Flow	Fig.
			Ø	$Q_n 2 \rightarrow 1$	
R412010564	Ø 4	M5	2 mm	70 l/min	Fig. 1
R412010565	Ø 6	M5	2 mm	110 l/min	Fig. 1
R412010568	Ø 4	G 1/8	3.5 mm	150 l/min	Fig. 2
R412010569	Ø 6	G 1/8	3.5 mm	390 l/min	Fig. 2
R412010570	Ø 8	G 1/8	3.5 mm	470 l/min	Fig. 2

Nominal flow Q_n at 6 bar and $\Delta p = 1$ bar

Technical information

Material	
Housing	Polyamide
Seals	Acrylonitrile butadiene rubber
Port	Brass, nickel-plated

Dimensions

Dimensions

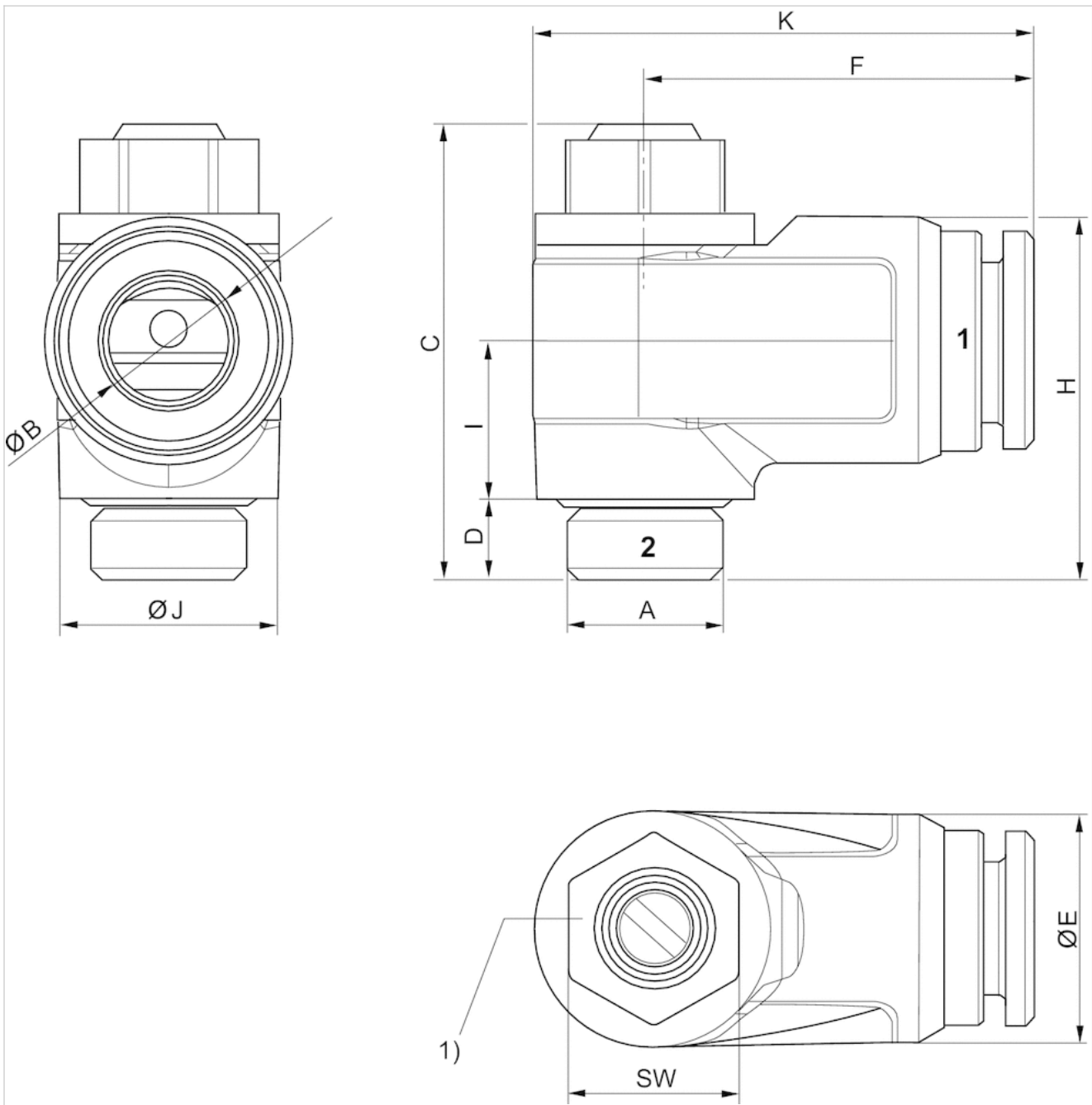

1) Recommended tightening torque MA:

- M 5: 1.1 Nm -0.2
- G 1/8: 3.0 Nm -0.3
- G 1/4: 6.0 Nm -0.6
- G 3/8: 8.0 Nm -1.0
- G 1/2: 10.0 Nm -1.0

Dimensions

Part No.	Port 1	Port 2	Ø B	C	D	Ø E	F	K	H	I	Ø J	SW
R412010564	Ø 4	M5	4	21.8	4	9	15.9	20.4	12	7.5	8.7	7
R412010565	Ø 6	M5	6	21.8	4	11.1	17.2	21.8	13	7.5	8.7	7

Part No.	Port 1	Port 2	Ø B	C	D	Ø E	F	K	H	I	Ø J	SW
R412010568	Ø 4	G 1/8	4	28.5	5.5	11.5	21.9	28.8	21	9.8	13.6	10
R412010569	Ø 6	G 1/8	6	28.5	5.5	13.5	22.4	29.3	21.7	9.8	13.6	10
R412010570	Ø 8	G 1/8	8	28.5	5.5	15.5	24.2	31.1	22.7	9.8	13.6	10

Diagrams

Flow diagram, Fig. 1

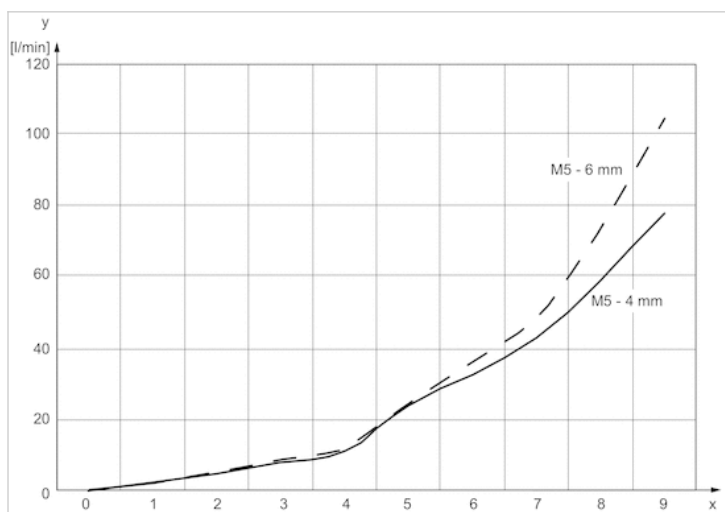

x = rotations of the throttle screw

y = flow rate Qn

Flow diagram, Fig. 2

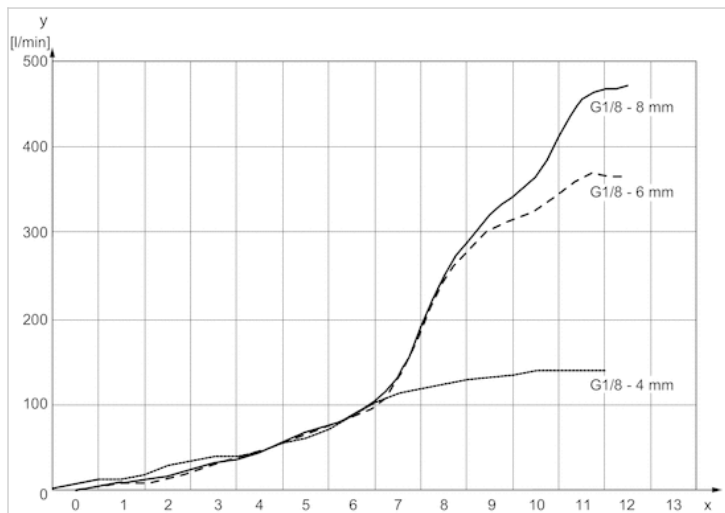

x = rotations of the throttle screw

y = flow rate Qn

Flow diagram, Fig. 3

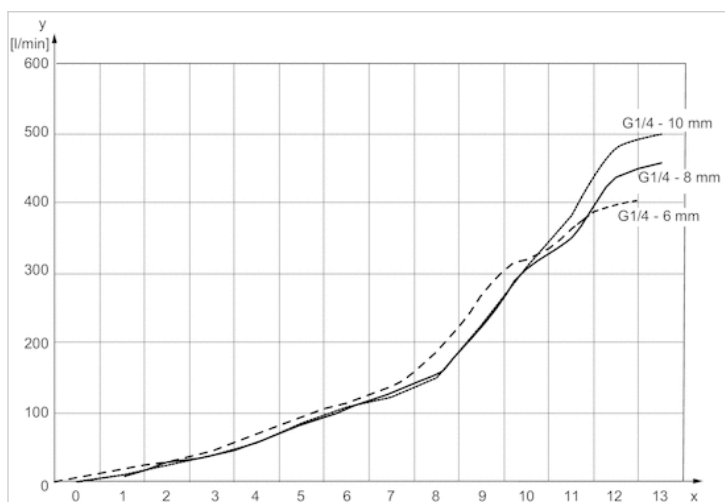

x = rotations of the throttle screw
 y = flow rate Qn

Flow diagram, Fig. 4

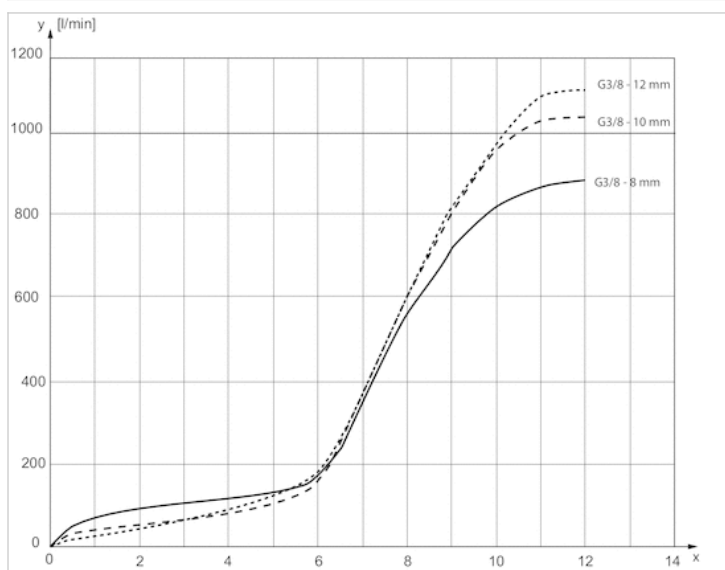

x = rotations of the throttle screw
 y = flow rate Qn

Flow diagram, Fig. 5

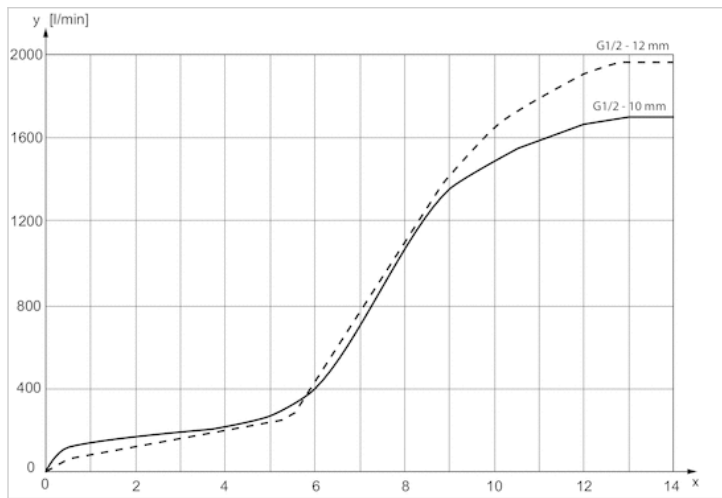

x = rotations of the throttle screw
y = flow rate Q_n

Check-choke valve, stainless steel, Series CC02-SL

- $Q_n 1 \rightarrow 2 = 150-190 \text{ l/min}$
- direction of throttle $1 \rightarrow 2$
- inlet-side throttling
- push-in fitting / External thread
- Heat resistant



Working pressure min./max.	0.5 ... 10 bar
Ambient temperature min./max.	0 ... 150 °C
Medium temperature min./max.	0 ... 150 °C
Medium	Compressed air

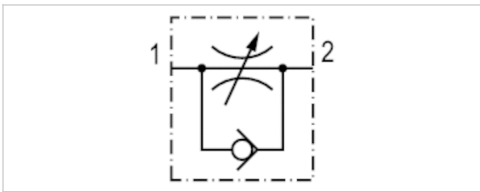

Technical data

Part No.	Port 1	Port 2	Flow	Delivery unit	Fig.
			$Q_n 1 \rightarrow 2$		
R412024749	Ø 4	G 1/8	150 l/min	1 piece	Fig. 1
R412024750	Ø 6	G 1/8	190 l/min	1 piece	Fig. 2

Nominal flow Q_n at 6 bar and $\Delta p = 1 \text{ bar}$

Technical information

Materials according to AISI/FDA:
 Housing ▶ Stainless steel AISI 316L (1.4404)
 Flow control screw ▶ Stainless steel AISI 316L (1.4404)
 Seal ▶ FKM (FDA-compliant)
 Stainless steel connection ▶ AISI 316L (1.4404)

Technical information

Material	
Housing	Stainless steel
Flow control screw	Stainless steel

Material	
Seals	Fluorocaoutchouc

Dimensions

Dimensions

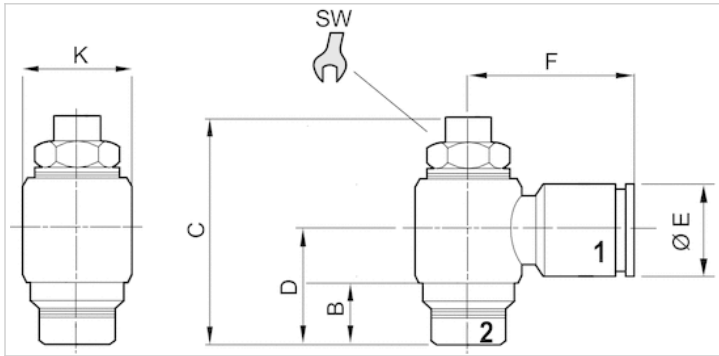

Dimensions

Part No.	Port 1	Port 2	B	C	D	ØE	F	ØK	SW
R412024749	Ø 4	G 1/8	5	32	15.5	9	19.5	14	9
R412024750	Ø 6	G 1/8	5	32	15.5	12	22	14	9

Diagrams

Flow diagram, Fig. 1

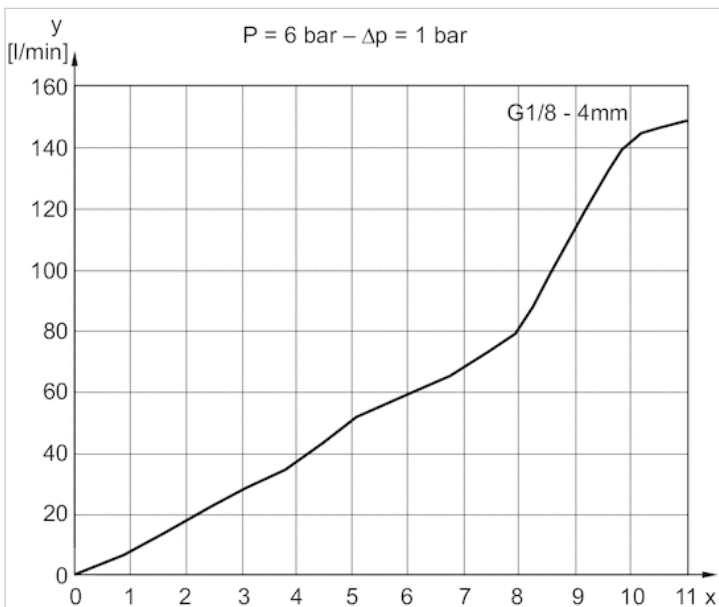

Flow diagram, Fig. 3

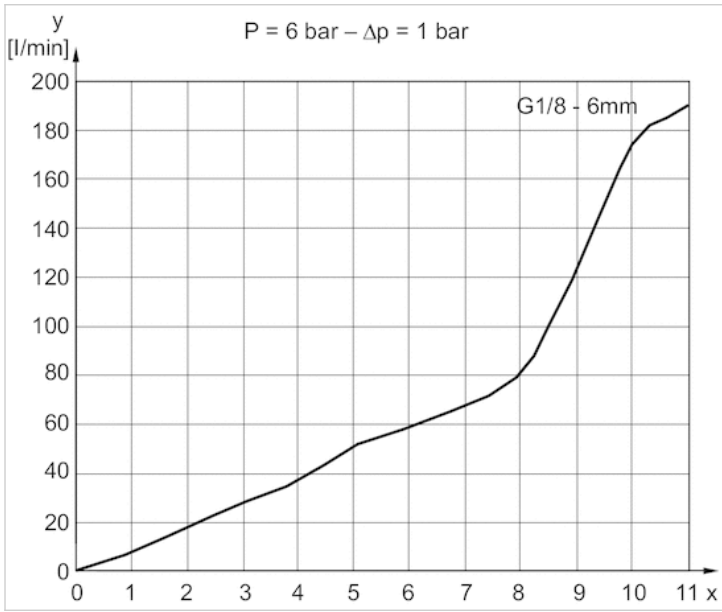

Flow diagram, Fig. 4

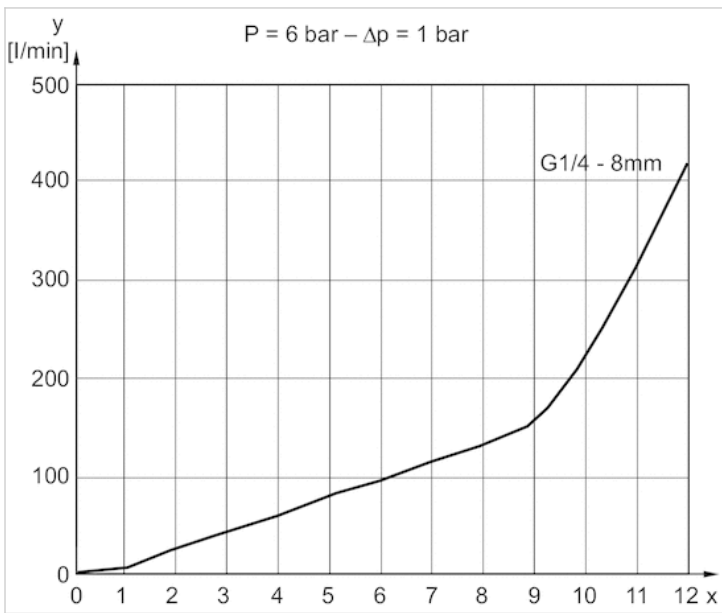

Flow diagram, Fig. 5

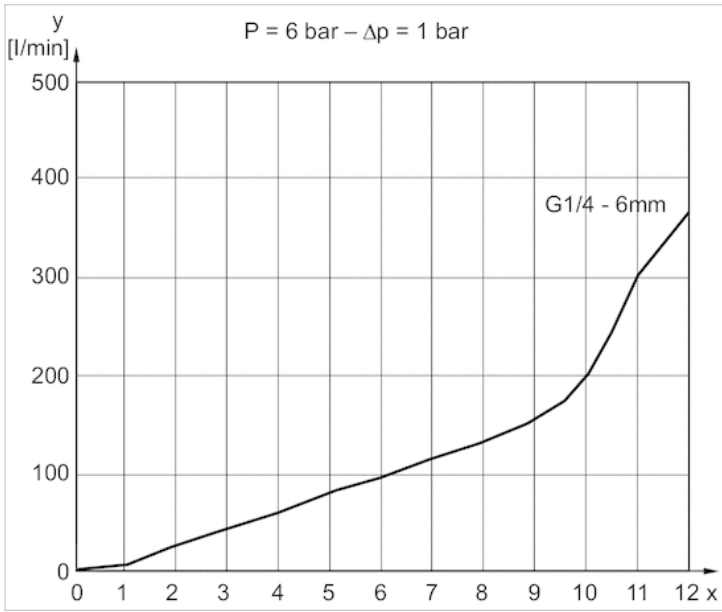

Flow diagram, Fig. 5

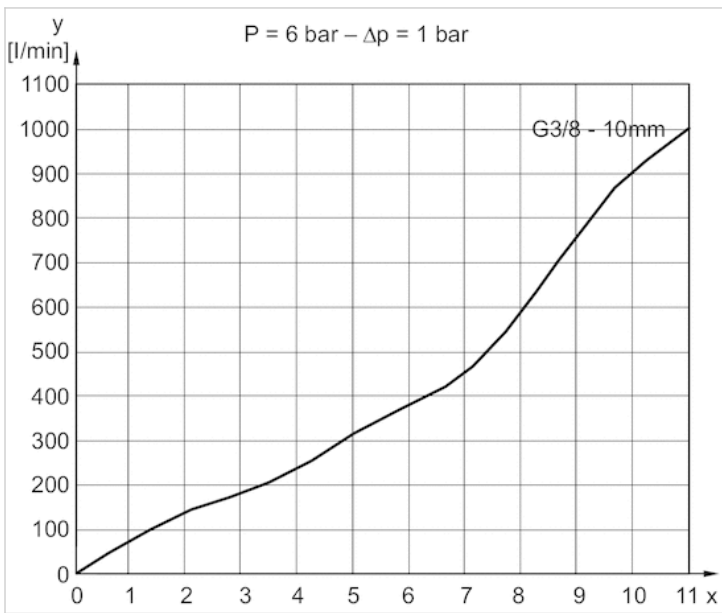

Sensor mounting, Series CB1

- for series ST4, ST6

- to mount on cylinder MNI, ICM, CSL-RD



Ambient temperature min./max.

-30 ... 80 °C

Weight

0.007 kg

Technical data

Part No.	Cylinders Ø	for series	Scope of delivery
	min.		
R412021791	16 mm	ST4, ST6	1 piece
R412021792	20 mm	ST4, ST6	1 piece
R412021793	25 mm	ST4, ST6	1 piece

Technical information

Material	
	Polyamide Stainless steel

Dimensions

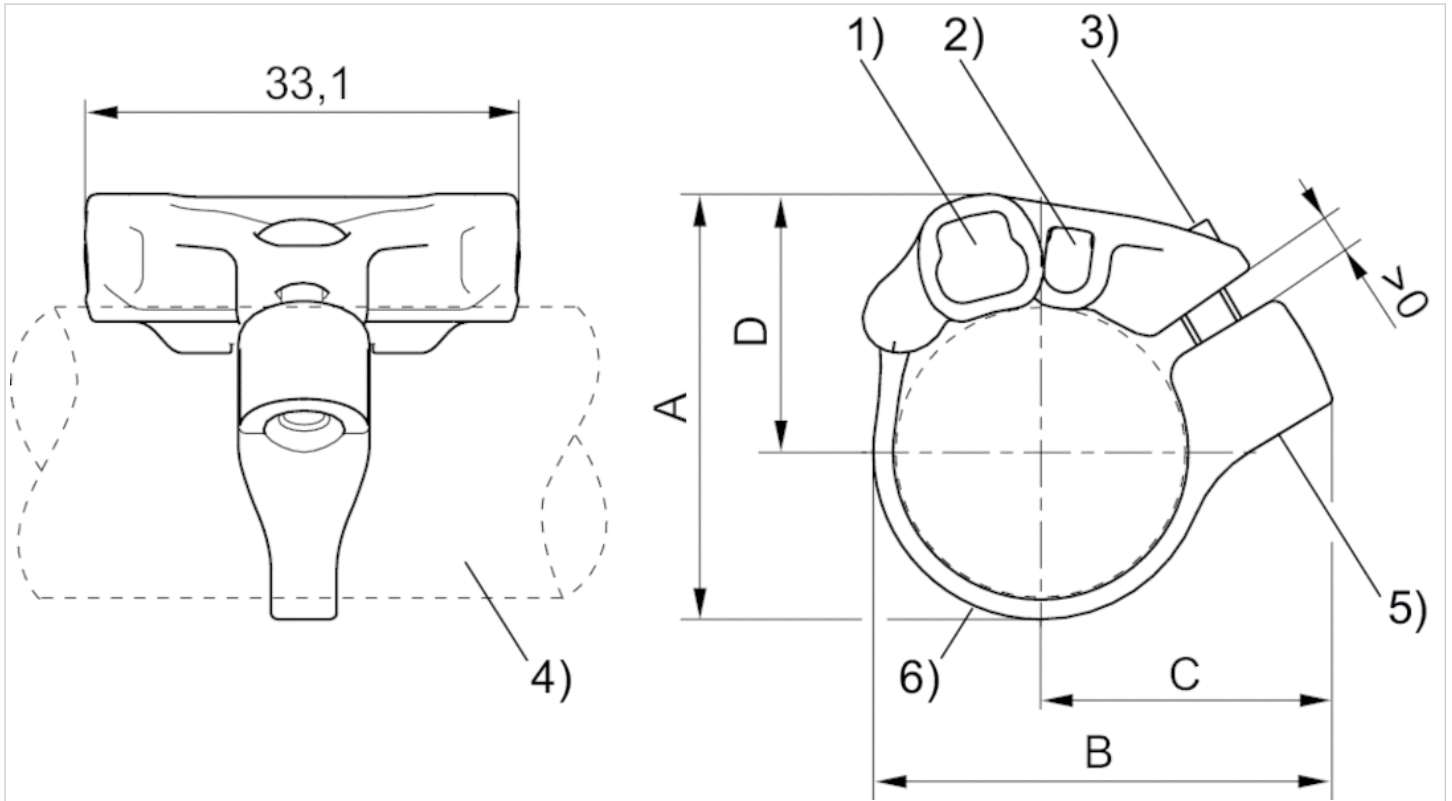

1) Sensor slot for ST6 2) Sensor slot for ST4 3) Mounting screw (made of stainless steel) 4) Cylinder profile 5) Thread insert (made of stainless steel) 6) Tightening strap

Dimensions

Part No.	A	B	C	D
R412021791	27.7	32.5	22.1	17.3
R412021792	32.4	35	22.4	19.7
R412021793	37.4	39.5	24.3	22.2

Series CAT

- Measuring instrument for adjusting the pneumatic cushioning
- for MNI, CSL-RD, CCL-IS, ICS, RPC, PRA/TRB, ITS



Certificates	CE declaration of conformity
Ambient temperature min./max.	0 ... 40 °C
Measurement range Min.	0.2 m/s
Measurement range Max.	2 m/s
LED status display	Green Yellow Red
Protection class	IP50
Weight	0.12 kg

Technical data

Part No.	for series
R412026160	MNI, CSL-RD, CCL-IS, ICS, RPC, PRA/TRB, ITS

Scope of delivery: 1 measuring instrument, 2 fastening strips, 1 power pack 3.7 V, 1 USB charging cable, Operating instructions, QR code notice, 1 case with foam inlay

Technical information

The CAT measuring instrument uses Bluetooth radio technology for wireless connection with the "Aventics" app, which is available free of charge in the Android/Play Store and/or the IOS/App Store.

Technical information

Material	
Housing	Luran S

Dimensions

Dimensions

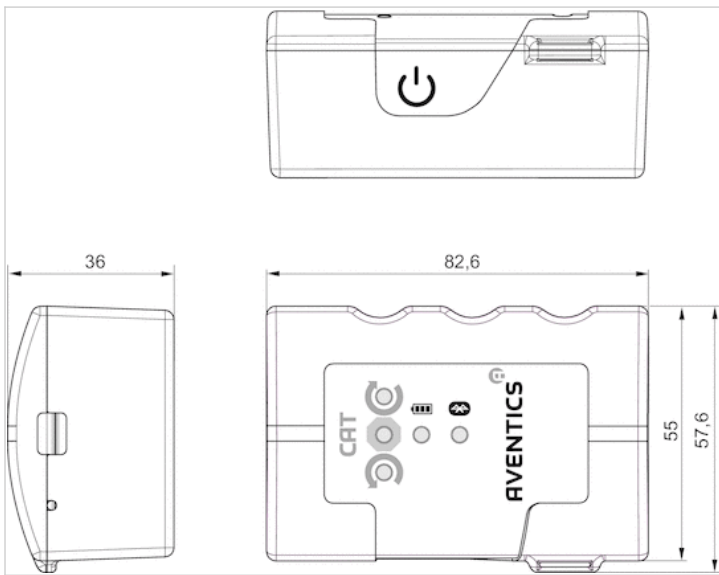

Sensor mounting, Series CB1

- for series ST6

- to mount on cylinder CSL-RD, ICM, ICS-D1, ICS-D2, RPC

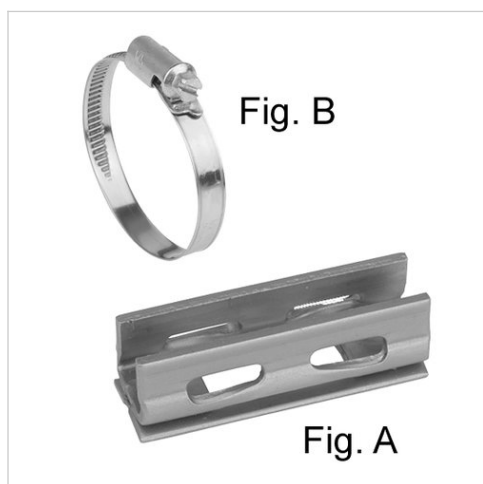

Weight

See table below

Technical data

Part No.	Cylinders Ø		for series	Weight	Fig.
	min.	max.			
R412024050	25 mm	32 mm	ST6	-	Fig. B
R412024054	25 mm	63 mm	ST6	0.011 kg	Fig. A

Sensor holder (Fig. A) and tightening strap (Fig. B) must be ordered separately.

Technical information

Material	
	Stainless steel

Dimensions

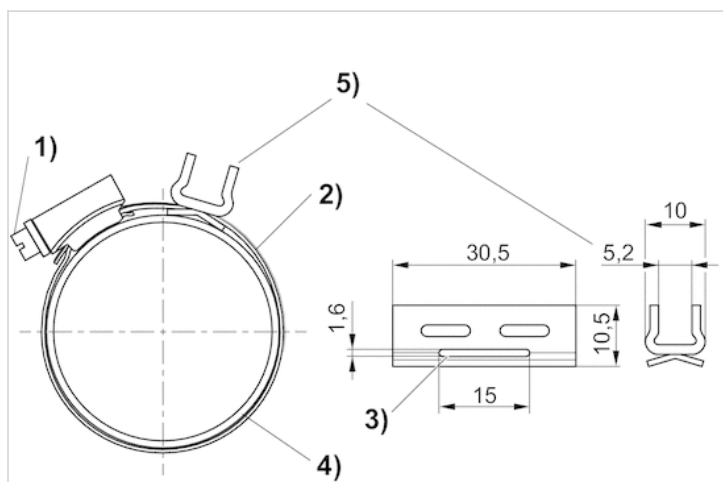

1) Mounting screw 2) Tightening strap 3) Opening for tightening strap 4) Cylinder tube 5) Sensor holder

Dimensions

Part No.	Cylinder tube Ø	For series	Fig.
R412024050	25 40 mm	ST6	Fig. B
R412024054	-	ST6	Fig. A

Sensor, Series ST6

- 6 mm T-slot
- with cable
- open cable ends, 3-pin
- ATEX
- UL certification, ATEX
- electronic PNP
- Direct mounting for series PRA, PRE, CCI, KPZ, SSI, GPC, CVI
- Indirect mounting for series TRB, ITS, CCL-IS, MNI, CSL-RD, RPC, ICS-D2, ICM, KHZ, TRR

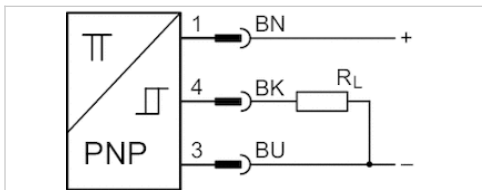

Certificates

- ATEX class G
- ATEX class D
- Ambient temperature min./max.
- Protection class
- Switching point precision
- Quiescent current (without load)
- Min./max. DC operating voltage
- Switching logic
- LED status display
- Vibration resistance
- Shock resistance
- Cable length L

- ATEX CE declaration of conformity cULus RoHS
- II 3G Ex nA IIC T4 Gc X
- II 3D Ex tc IIIC T135°C Dc X
- 20 ... 50 °C
- IP67
- ±0,1 mT
- 10 mA
- 10 ... 30 V DC
- NO (make contact)
- Yellow
- 10 - 55 Hz, 1 mm
- 30 g / 11 ms
- 3 5 m

Technical data

Part No.	for	Type of contact	Cable length L
R412022854	PRA, PRE, CCI, KPZ, SSI, GPC, CVI	electronic PNP	3 m
R412022856	PRA, PRE, CCI, KPZ, SSI, GPC, CVI	electronic PNP	5 m

Part No.	Voltage drop U at I _{max}	DC switching current, max.
R412022854	≤ 2,5 V	0.1 A
R412022856	≤ 2,5 V	0.1 A

Part No.	Max. switching frequency
R412022854	1000 Hz
R412022856	1000 Hz

Part No.	Version
R412022854	short circuit resistant Protected against polarity reversal

Part No.	Version
R412022856	short circuit resistant Protected against polarity reversal

Technical information

Material	
Housing	Polyamide
Cable sheath	Polyurethane
Locking screw	Stainless steel

Dimensions

Fig. 2

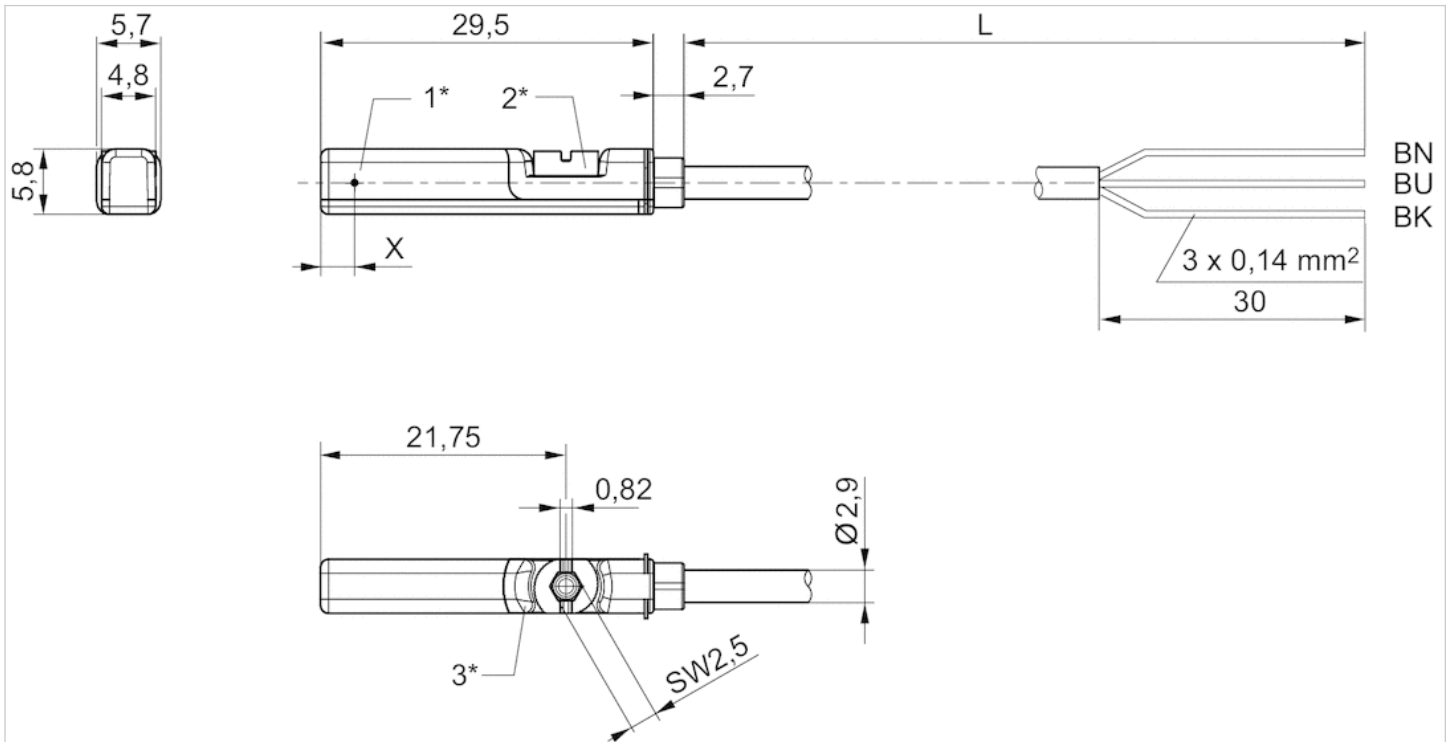

1* = switching point 2* = locking screw 3* = LED window, transparent
 L = cable length
 BN = brown, BK = black, BU = blue
 X = electronic: 11.6 mm





Sensor, Series ST6

- 6 mm T-slot
- with cable
- open cable ends, 3-pin
- UL certification
- Reed electronic PNP
- Direct mounting for series PRA, PRE, CCI, KPZ, SSI, GPC, CVI
- Indirect mounting for series TRB, ITS, CCL-IS, MNI, CSL-RD, RPC, ICS-D2, ICM, KHZ, TRR



Certificates	CE declaration of conformity cULus RoHS
Ambient temperature min./max.	-30 ... 80 °C
Protection class	IP65 IP67 IP69K
Switching point precision	±0,1 mT
Nominal current, actuated state	30 mA
Quiescent current (without load)	8 mA
Min./max. DC operating voltage	10 ... 30 V DC
Min./max. AC operating voltage	See table below
Hysteresis	≥ 0,2 mT
Switching logic	NO (make contact)
LED status display	Yellow
Vibration resistance	10 - 55 Hz, 1 mm
Shock resistance	30 g / 11 ms
Cable length L	3 5 10 m

Technical data

Part No.		for	Type of contact
R412022869		PRA, PRE, CCI, KPZ, SSI, GPC, CVI	Reed
R412022870		PRA, PRE, CCI, KPZ, SSI, GPC, CVI	Reed
R412022871		PRA, PRE, CCI, KPZ, SSI, GPC, CVI	Reed
R412022853		PRA, PRE, CCI, KPZ, SSI, GPC, CVI	electronic PNP
R412022855		PRA, PRE, CCI, KPZ, SSI, GPC, CVI	electronic PNP

Part No.	Cable length L	Min./max. AC operating voltage	Voltage drop U at I _{max}
R412022869	3 m	10 ... 30 V AC	I*Rs
R412022870	5 m	10 ... 30 V AC	≤ 0,1 V
R412022871	10 m	10 ... 30 V AC	I*Rs
R412022853	3 m	-	≤ 2,5 V
R412022855	5 m	-	≤ 2,5 V

Part No.	DC switching current, max.	AC switching current, max.
R412022869	0.3 A	0.5 A
R412022870	0.3 A	0.5 A
R412022871	0.3 A	0.5 A
R412022853	0.13 A	-

Part No.	DC switching current, max.	AC switching current, max.
R412022855	0.13 A	-

Part No.	Switching capacity	Max. switching frequency
R412022869	Reed, 3-pin: max. 6 W	400 Hz
R412022870	Reed, 3-pin: max. 6 W	400 Hz
R412022871	Reed, 3-pin: max. 6 W	400 Hz
R412022853	-	1000 Hz
R412022855	-	1000 Hz

Part No.	Operating current, not switched	Operating current, switched
R412022869	-	-
R412022870	-	-
R412022871	-	-
R412022853	8 mA	30 mA
R412022855	8 mA	30 mA

Part No.	Version	Fig.	
R412022869	Protected against polarity reversal	Fig. 2	1)
R412022870	Protected against polarity reversal	Fig. 2	1)
R412022871	Protected against polarity reversal	Fig. 2	1)
R412022853	short circuit resistant Protected against polarity reversal	Fig. 2	2)
R412022855	short circuit resistant Protected against polarity reversal	Fig. 2	2)

1) open cable ends, 3-pin, The product of operating voltage and continuous current must not exceed the maximum switching capacity.

2) open cable ends, 3-pin

Technical information

No cULus certification for 230 V variant.

Technical information

Material	
Housing	Polyamide
Cable sheath	Polyurethane
Locking screw	Stainless steel

Dimensions

Fig. 1

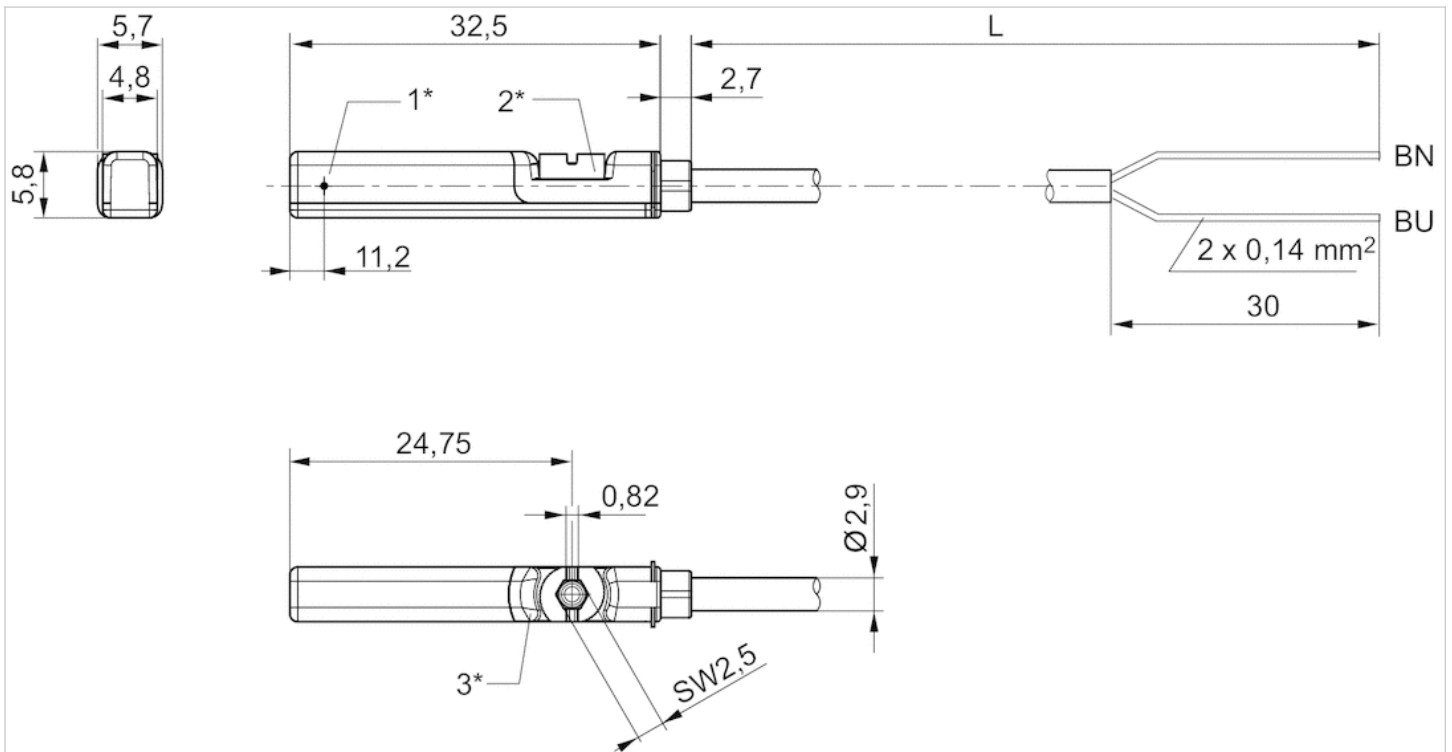

1* = switching point 2* = locking screw 3* = LED window, transparent
 L = cable length
 BN=brown, BU=blue

Fig. 2

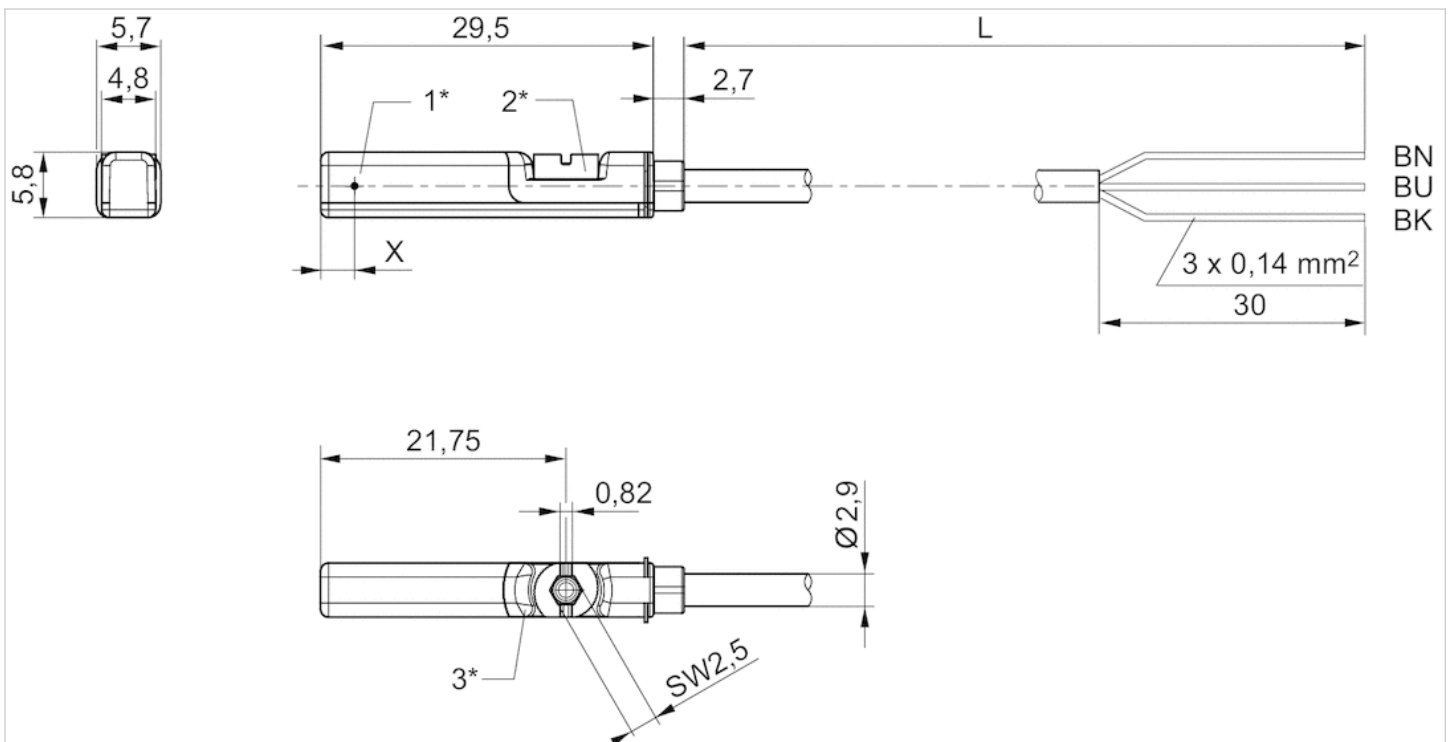

1* = switching point 2* = locking screw 3* = LED window, transparent
 L = cable length

BN = brown, BK = black, BU = blue
X = electronic: 11.6 mm

Sensor, Series ST6

- 6 mm T-slot
- with cable
- Plug, M8, 3-pin, with knurled screw
- ATEX
- UL certification, ATEX
- electronic PNP
- Direct mounting for series PRA, PRE, CCI, KPZ, SSI, GPC, CVI
- Indirect mounting for series TRB, ITS, CCL-IS, MNI, CSL-RD, RPC, ICS-D2, ICM, KHZ, TRR



Certificates	ATEX CE declaration of conformity cULus RoHS
ATEX class G	II 3G Ex nA IIC T4 Gc X
ATEX class D	II 3D Ex tc IIIC T135°C Dc X
Ambient temperature min./max.	-20 ... 50 °C
Protection class	IP65 IP67
Switching point precision	±0,1 mT
Quiescent current (without load)	10 mA
Min./max. DC operating voltage	10 ... 30 V DC
Switching logic	NO (make contact)
LED status display	Yellow Yellow
Vibration resistance	10 - 55 Hz, 1 mm
Shock resistance	30 g / 11 ms
Cable length L	0.3 m

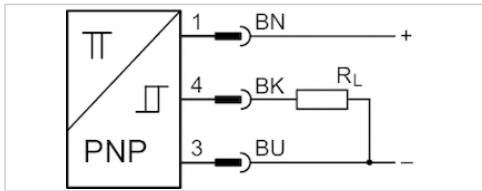

Technical data

Part No.	for	Type of contact	Cable length L
R412022860	PRA, PRE, CCI, KPZ, SSI, GPC, CVI	electronic PNP	0.3 m

Part No.	Voltage drop U at I _{max}	DC switching current, max.
R412022860	≤ 2,5 V	0.1 A

Part No.	Max. switching frequency
R412022860	1000 Hz

Part No.	Version
R412022860	short circuit resistant Protected against polarity reversal

Technical information

Material

Housing	Polyamide
Cable sheath	Polyurethane
Locking screw	Stainless steel

Dimensions

Dimensions

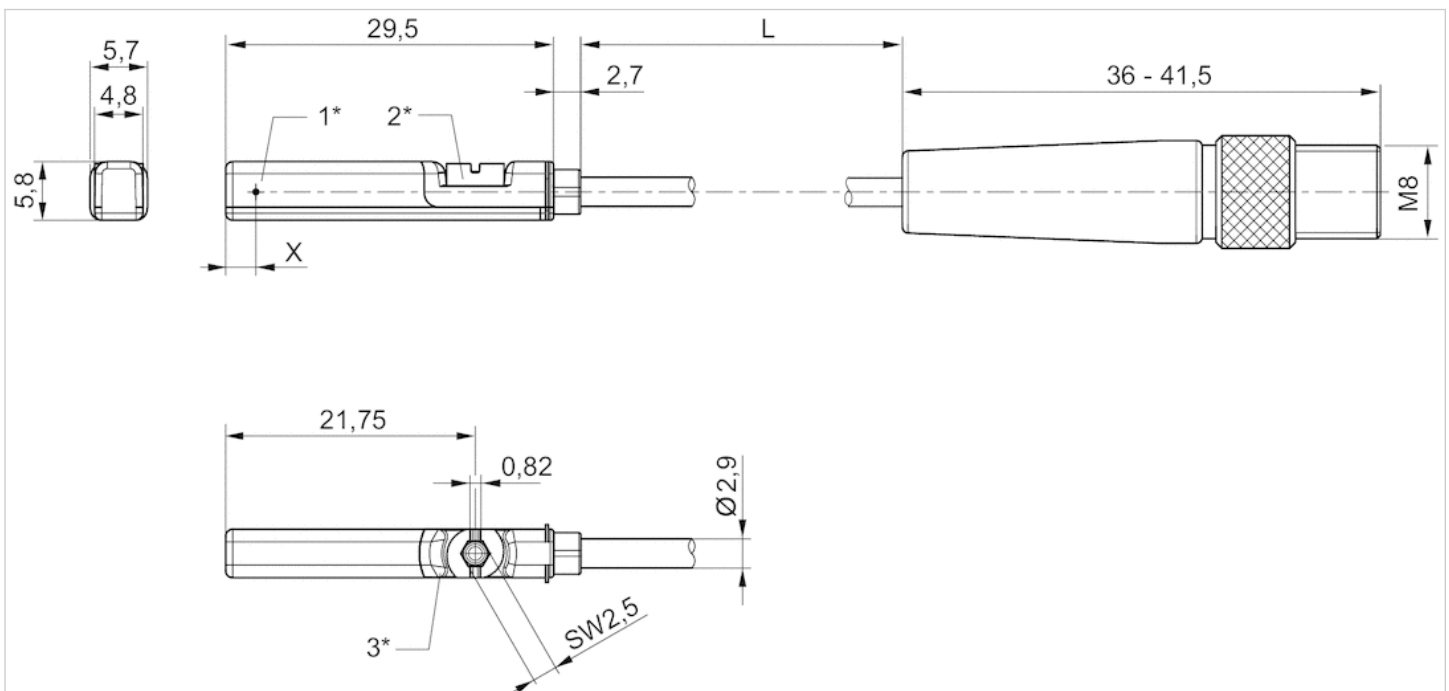

1* = switching point 2* = locking screw 3* = LED window, transparent
 L = cable length
 X = electronic: 11,6 mm, Reed: 8,3 mm

Pin assignments

Pin assignments

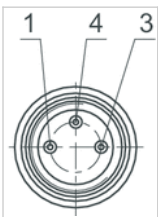

Pin	1	3	4
Allocation	(+)	(-)	(OUT)

Sensor, Series ST6

- 6 mm T-slot
- with cable
- Plug, M8, 3-pin, with knurled screw
- UL certification
- Reed electronic PNP
- Direct mounting for series PRA, PRE, CCI, KPZ, SSI, GPC, CVI
- Indirect mounting for series TRB, ITS, CCL-IS, MNI, CSL-RD, RPC, ICS-D2, ICM, KHZ, TRR



Certificates	CE declaration of conformity cULus RoHS
Ambient temperature min./max.	-30 ... 80 °C
Protection class	IP65 IP67
Switching point precision	±0,1 mT
Nominal current, actuated state	30 mA
Quiescent current (without load)	8 mA
Min./max. DC operating voltage	10 ... 30 V DC
Min./max. AC operating voltage	See table below
Hysteresis	≥ 0,2 mT
Switching logic	NO (make contact)
Switching capacity	Reed, 3-pin: max. 6 W
LED status display	Yellow
Vibration resistance	10 - 55 Hz, 1 mm
Shock resistance	30 g / 11 ms
Cable length L	0.3 m

Technical data

Part No.		for	Type of contact
R412022875		PRA, PRE, CCI, KPZ, SSI, GPC, CVI	Reed
R412022859		PRA, PRE, CCI, KPZ, SSI, GPC, CVI	electronic PNP

Part No.	Cable sheath	Cable length L	Min./max. AC operating voltage
R412022875	Polyvinyl chloride	0.3 m	10 ... 30 V AC
R412022859	Polyurethane	0.3 m	-

Part No.	Voltage drop U at I _{max}	DC switching current, max.
R412022875	I*Rs	0.3 A
R412022859	≤ 2,5 V	0.13 A

Part No.	AC switching current, max.	Max. switching frequency
R412022875	0.5 A	400 Hz
R412022859	-	1000 Hz

Part No.	Operating current, not switched	Operating current, switched
R412022875	-	-
R412022859	8 mA	30 mA

Part No.	Version
R412022875	Protected against polarity reversal
R412022859	short circuit resistant Protected against polarity reversal

Technical information

Material	
Housing	Polyamide
Cable sheath	Polyvinyl chloride Polyurethane
Locking screw	Stainless steel

Dimensions

Dimensions

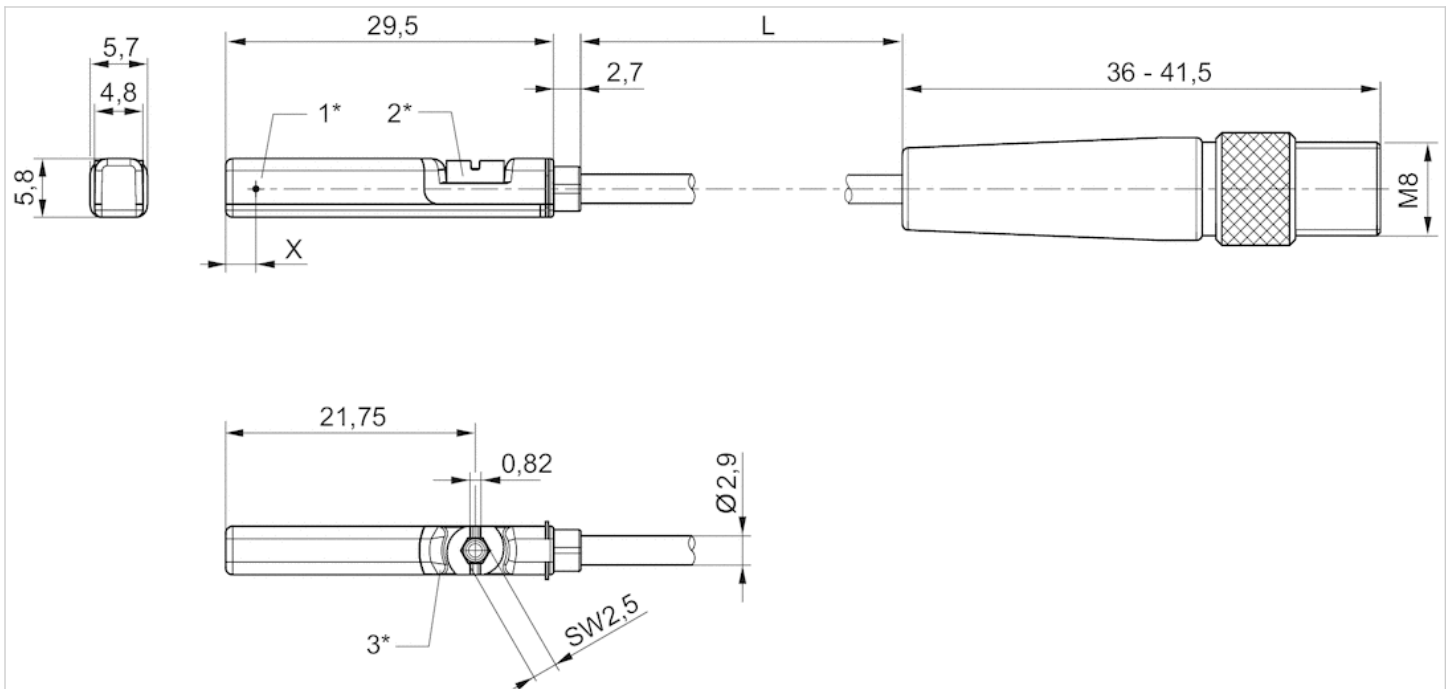

1* = switching point 2* = locking screw 3* = LED window, transparent
 L = cable length
 X = electronic: 11,6 mm, Reed: 8,3 mm

Pin assignments

Pin assignments

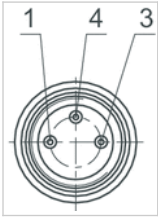

Pin	1	3	4
Allocation	(+)	(-)	(OUT)

Sensor, Series ST4

- 4 mm T-slot
- with cable
- Plug, M8, 3-pin
- UL certification
- Reed electronic PNP
- Direct mounting for series PRA, SSI, GSU, RTC, CKP, GSP, MSC, MSN, RCM, CVI
- Indirect mounting for series MNI, CSL-RD, ICM



Certificates	UL (Underwriters Laboratories) cULus RoHS
Ambient temperature min./max.	-30 ... 80 °C
Protection class	IP65 IP67
Switching point precision	±0,1 mT
Min./max. DC operating voltage	See table below
Switching logic	NO (make contact)
Display	LED
LED status display	Yellow
Vibration resistance	10 - 55 Hz, 1 mm
Shock resistance	30 g / 11 ms
Cable length L	0.3 m
Mounting screw	Combination: slotted and hexagon socket

Technical data

Part No.		for
R412019682		PRA, SSI, GSU, RTC, CKP, GSP, MSC, MSN, RCM, CVI
R412019683		PRA, SSI, GSU, RTC, CKP, GSP, MSC, MSN, RCM, CVI

Part No.	Type of contact	Cable length L	Min./max. DC operating voltage
R412019682	Reed	0.3 m	5 ... 30 V DC
R412019683	electronic PNP	0.3 m	10 ... 30 V DC

Part No.	Voltage drop U at I _{max}	DC switching current, max.
R412019682	≤ 0,5 V	0.13 A
R412019683	≤ 2,5 V	0.1 A

Part No.	AC switching current, max.	Switching capacity
R412019682	0.13 A	3 W / 3 VA
R412019683	-	-

Part No.	Version
R412019682	Protected against polarity reversal

Part No.	Version
R412019683	short circuit resistant Protected against polarity reversal

Technical information

The max. switching capacity must not be exceeded.

Technical information

Material	
Housing	Polyamide fiber-glass reinforced
Cable sheath	Polyurethane

Dimensions

Dimensions

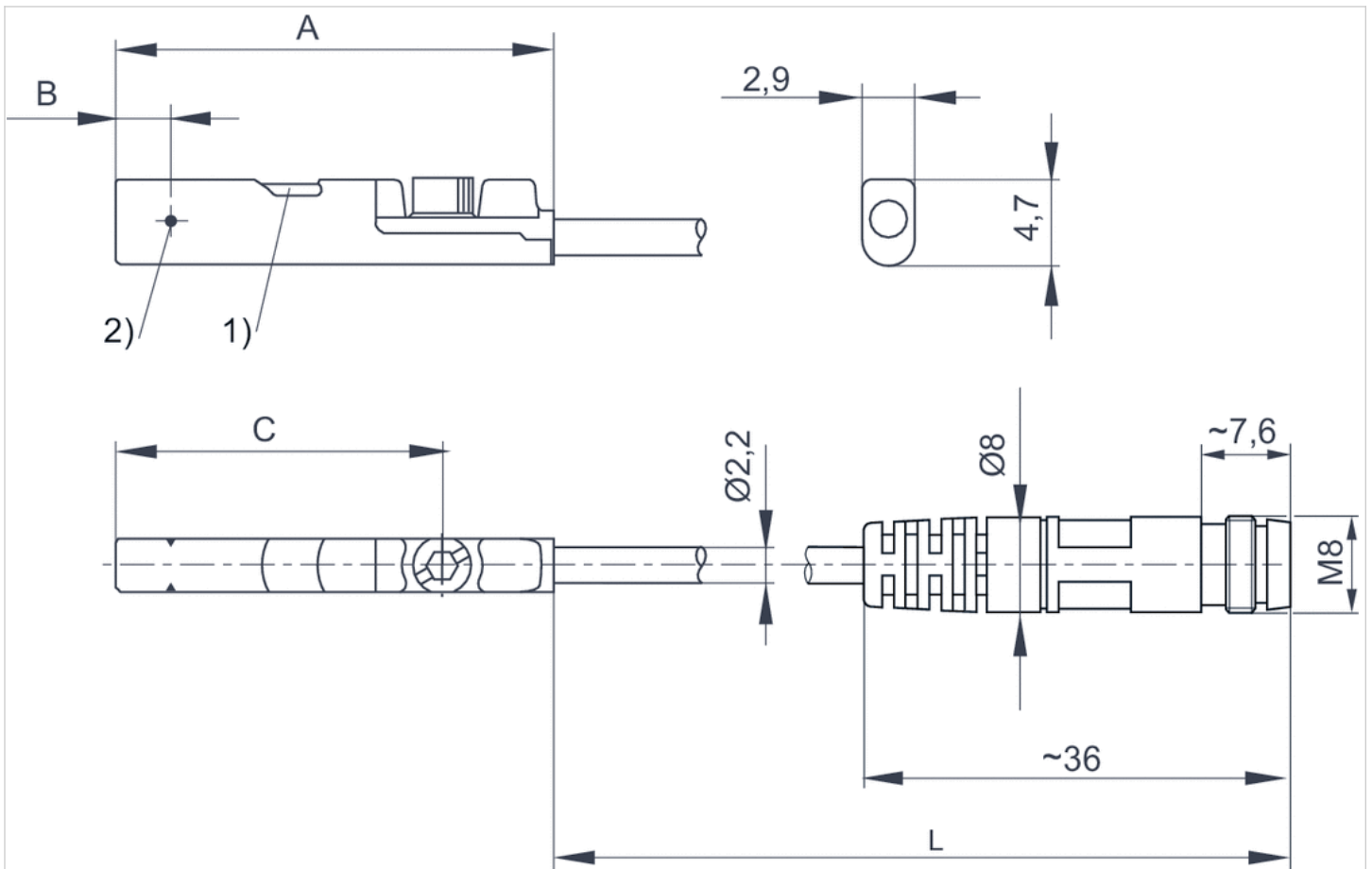

1) LED 2) Switching point
L = cable length

Dimensions

Part No.	A	B	C
R412019682	26.3	6.3	20.3
R412019683	23.7	2.8	17.7

Pin assignments

Pin assignments

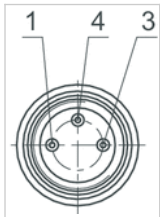

Pin	1	3	4
Allocation	(+)	(-)	(OUT)

Sensor, Series ST4

- 4 mm T-slot
- with cable
- open cable ends, 3-pin
- UL certification
- Reed electronic PNP
- Direct mounting for series PRA, SSI, GSU, RTC, CKP, GPC, MSC, MSN, RCM, CVI
- Indirect mounting for series MNI, CSL-RD, ICM



Certificates	UL (Underwriters Laboratories) cULus RoHS
Ambient temperature min./max.	-30 ... 80 °C
Protection class	IP65 IP67
Switching point precision	±0,1 mT
Min./max. DC operating voltage	See table below
Switching logic	NO (make contact)
Display	LED
LED status display	Yellow
Vibration resistance	10 - 55 Hz, 1 mm
Shock resistance	30 g / 11 ms
Cable length L	3 5 m
Mounting screw	Combination: slotted and hexagon socket

Technical data

Part No.		for
R412019488		PRA, SSI, GSU, RTC, CKP, GPC, MSC, MSN, RCM, CVI
R412019489		PRA, SSI, GSU, RTC, CKP, GPC, MSC, MSN, RCM, CVI
R412019680		PRA, SSI, GSU, RTC, CKP, GPC, MSC, MSN, RCM, CVI
R412019681		PRA, SSI, GSU, RTC, CKP, GPC, MSC, MSN, RCM, CVI

Part No.	Type of contact	Cable length L	Min./max. DC operating voltage
R412019488	Reed	3 m	5 ... 30 V DC
R412019489	Reed	5 m	5 ... 30 V DC
R412019680	electronic PNP	3 m	10 ... 30 V DC
R412019681	electronic PNP	5 m	10 ... 30 V DC

Part No.	Voltage drop U at I _{max}	DC switching current, max.
R412019488	≤ 0,5 V	0.13 A
R412019489	≤ 0,5 V	0.13 A
R412019680	≤ 2,5 V	0.1 A
R412019681	≤ 2,5 V	0.1 A

Part No.	AC switching current, max.	Switching capacity
R412019488	0.13 A	3 W / 3 VA

Part No.	AC switching current, max.	Switching capacity
R412019489	0.13 A	3 W / 3 VA
R412019680	-	-
R412019681	-	-

Part No.	Version
R412019488	Protected against polarity reversal
R412019489	Protected against polarity reversal
R412019680	short circuit resistant Protected against polarity reversal
R412019681	short circuit resistant Protected against polarity reversal

Technical information

The max. switching capacity must not be exceeded.

Technical information

Material	
Housing	Polyamide fiber-glass reinforced
Cable sheath	Polyurethane

Dimensions

Dimensions

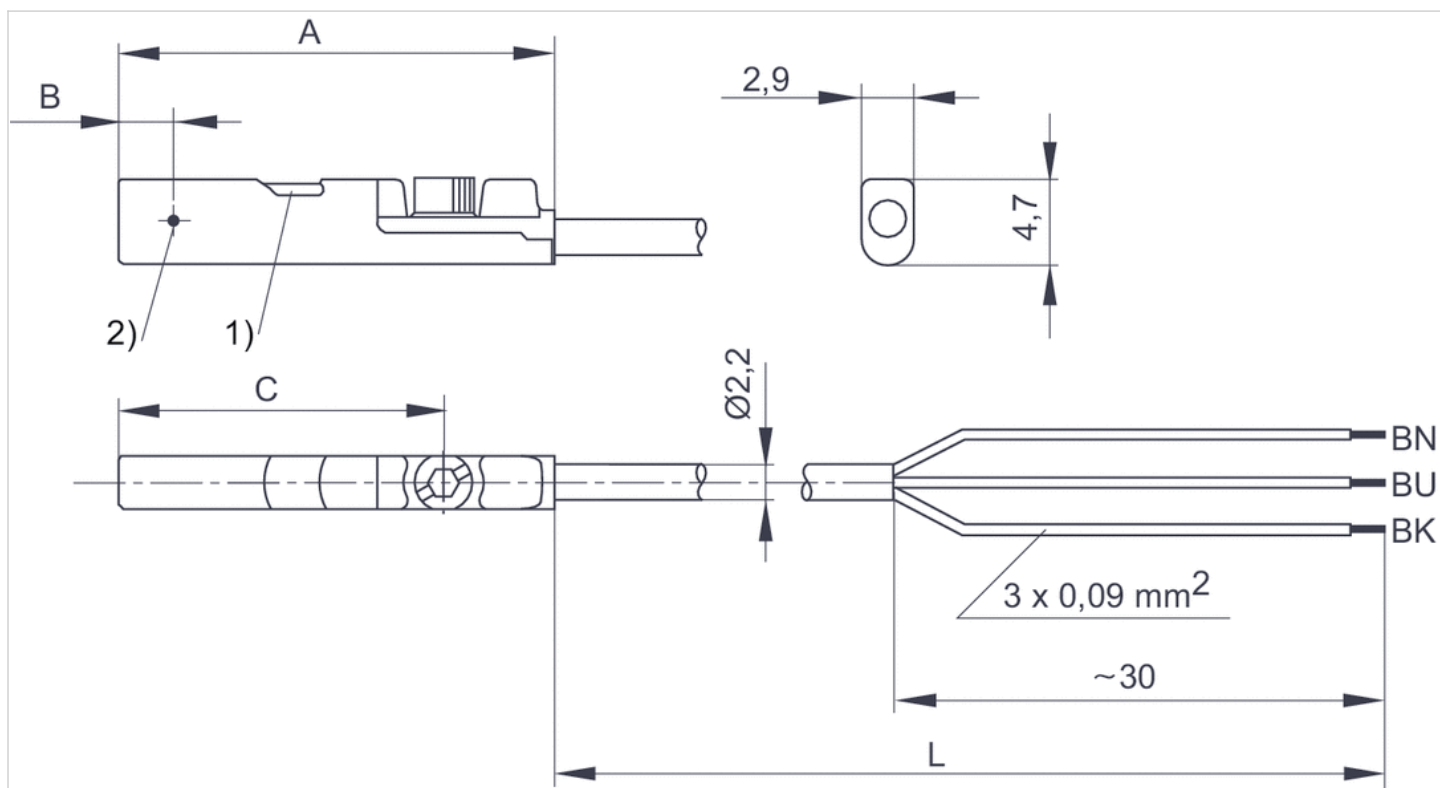

1) LED 2) Switching point

L = cable length

BN = brown, BK = black, BU = blue

Dimensions

Part No.	A	B	C
R412019488	26.3	6.3	20.3
R412019489	26.3	6.3	20.3
R412019680	23.7	2.8	17.7
R412019681	23.7	2.8	17.7

Series QR2-C-RPN, stainless steel

- Straight fitting
- External thread
- M5 G 1/8
- push-in fitting
- Ø 4 Ø 6 Ø 8
- QR2-C-RPN
- suitable for use in food processing



Working pressure min./max.

-0.95 ... 16 bar

Ambient temperature min./max.

-20 ... 150 °C

Weight per piece

See table below

Technical data

Part No.	Port G	Port D	Delivery unit	Weight per piece
2544004050	M5	Ø 4	2 piece	0.005 kg
R412004890	G 1/8	Ø 4	2 piece	0.008 kg
R412004891	G 1/8	Ø 6	2 piece	0.01 kg
R412004892	G 1/8	Ø 8	2 piece	0.013 kg

Technical information

The series QR1 (plastic) and QR2 (metal) can not be combined
Thread seal with captive O-ring

For further information about assembling and tolerances of adaptable tubing can be found in the "Technical information" document (available in the MediaCentre).

Technical information

Material	
Housing	Stainless steel
Seal	Fluorocaoutchouc
Tooth lock washer	Stainless steel
Release ring	Stainless steel
Thread	Stainless steel

Dimensions

Dimensions

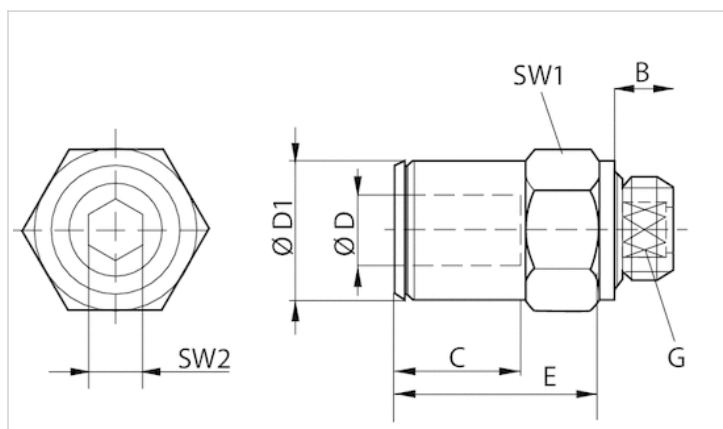

Dimensions

Part No.	Port D	Port G	A	B	C	E*	SW1	SW2	ØD1
2544004050	Ø 4	M5	20.5	4	7	15	9	–	9
R412004890	Ø 4	G 1/8	17	5.5	7	15	13	3	9
R412004891	Ø 6	G 1/8	23.5	5.5	12.5	16	13	4	11
R412004892	Ø 8	G 1/8	23.5	5.5	12.5	18	13	5	13

* Insertion depth

Series QR2-C-RVT , stainless steel

- Elbow fitting
- External thread
- M5 G 1/8
- push-in fitting
- Ø 4 Ø 6 Ø 8
- QR2-C-RVT
- suitable for use in food processing



Working pressure min./max.

-0.95 ... 16 bar

Ambient temperature min./max.

-20 ... 150 °C

Weight per piece

See table below

Technical data

Part No.	Port G	Port D	Delivery unit	Weight per piece
R412005617	M5	Ø 4	2 piece	0.008 kg
R412004898	G 1/8	Ø 4	2 piece	0.012 kg
R412004899	G 1/8	Ø 6	2 piece	0.02 kg
R412004900	G 1/8	Ø 8	2 piece	0.022 kg

Technical information

The series QR1 (plastic) and QR2 (metal) can not be combined
Thread seal with captive O-ring

For further information about assembling and tolerances of adaptable tubing can be found in the "Technical information" document (available in the MediaCentre).

Technical information

Material	
Housing	Stainless steel
Seal	Fluorocaoutchouc
Tooth lock washer	Stainless steel
Release ring	Stainless steel
Thread	Stainless steel

Dimensions

Dimensions

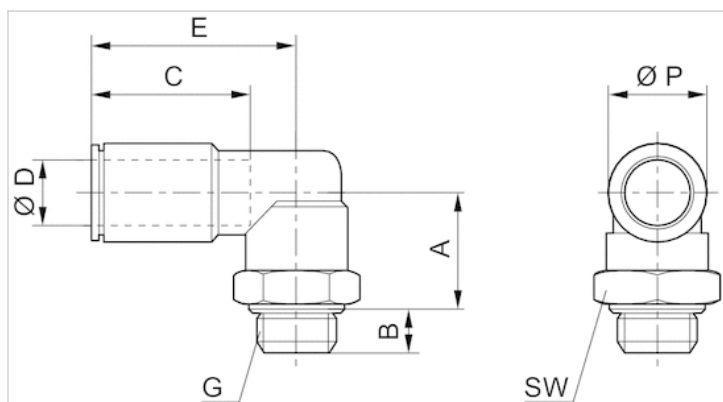

Dimensions

Part No.	Port D	Port G	A	B	C	E	SW	Ø P
R412005617	Ø 4	M5	15	4	15	14.5	9	9
R412004898	Ø 4	G 1/8	14.5	5.5	15	19.5	13	9
R412004899	Ø 6	G 1/8	16.5	5.5	16	19.5	13	11
R412004900	Ø 8	G 1/8	18.5	5.5	18	19.5	13	13

Silencers, series SI1

- M5 G 1/8
- Stainless steel



Working pressure min./max.	0 ... 12 bar
Ambient temperature min./max.	-20 ... 150 °C
Medium	Compressed air
Sound pressure level	See table below
Weight	See table below
Comment	Flow characteristic curves can be found under "Diagrams".

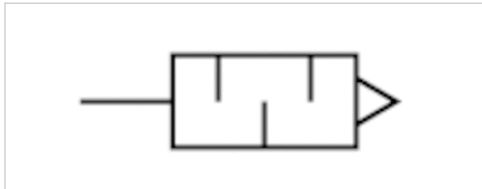

Technical data

Part No.	Compressed air connection	Sound pressure level	Flow	Delivery unit	Weight
			Qn		
R412010090	M5	85 dB	73 l/min	1 piece	0.003 kg
R412010081	G 1/8	90 dB	1312 l/min	1 piece	0.011 kg

Weight per piece

Nominal flow Qn at p1 = 6 bar (absolute) freely discharged. Sound pressure level measured at 6 bar against atmosphere at 1 m distance.

Technical information

Material	
Silencer	Stainless steel
Thread	Stainless steel

Dimensions

Dimensions

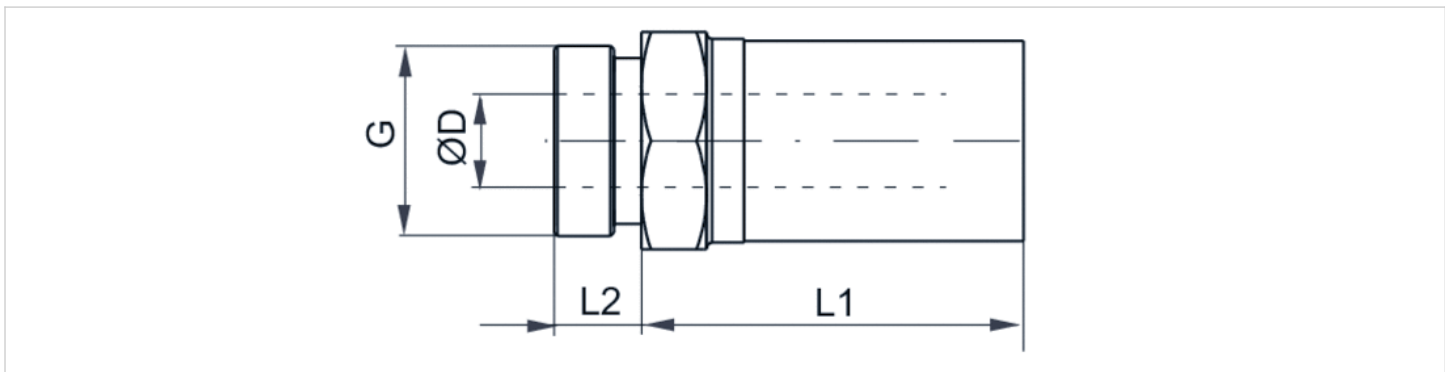

Dimensions

Part No.	Port G	SW	Ø D	L1	L2
R412010090	M5	8	3.1	10.5	3.5
R412010081	G 1/8	13	6.6	20	6

Diagrams

Flow diagram, R412010090

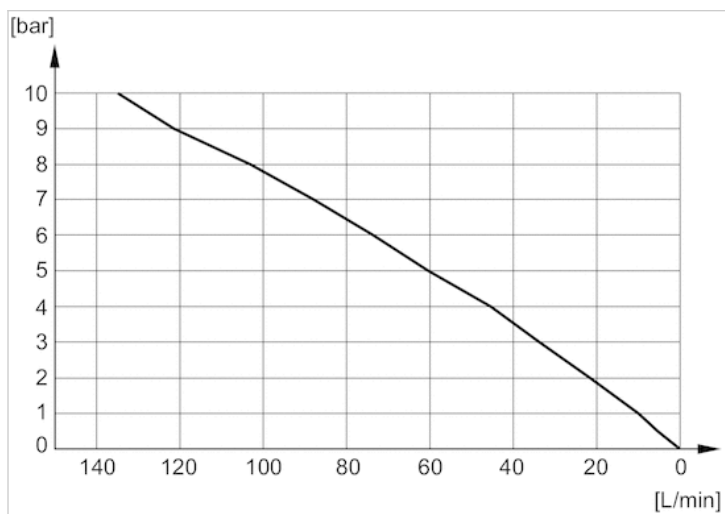

Flow diagram, R412010081

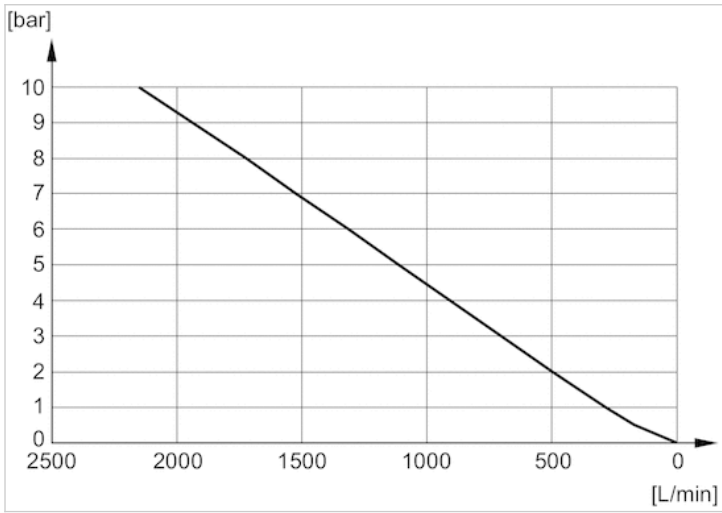

Flow diagram, R412010082

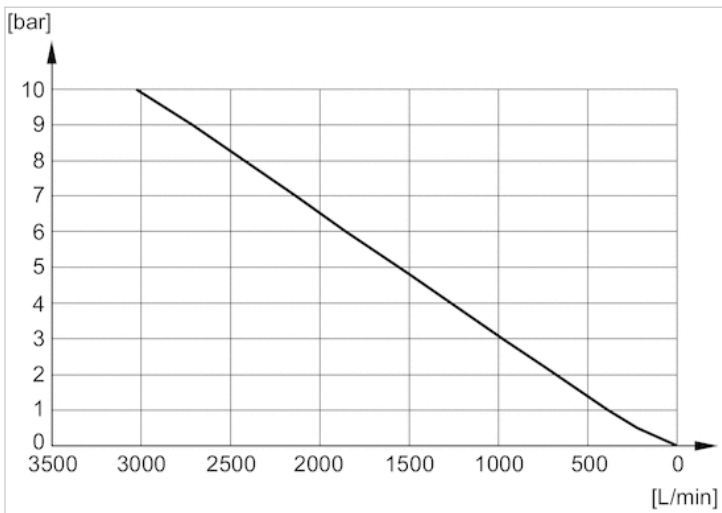

Flow diagram, R412010083

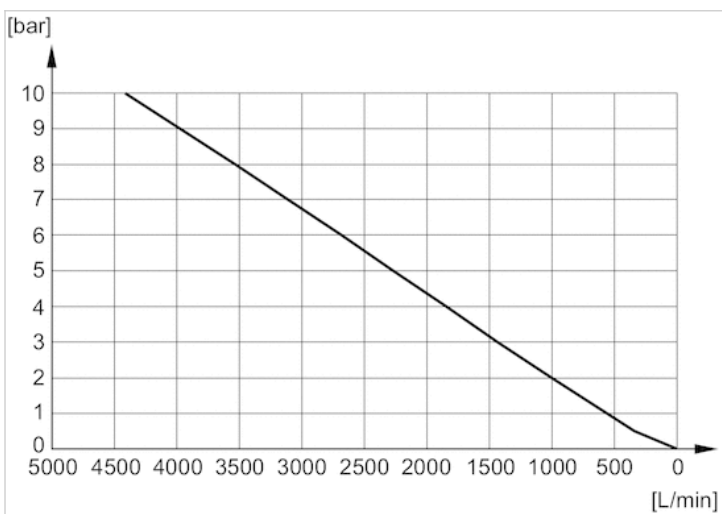

Flow diagram, R412010084

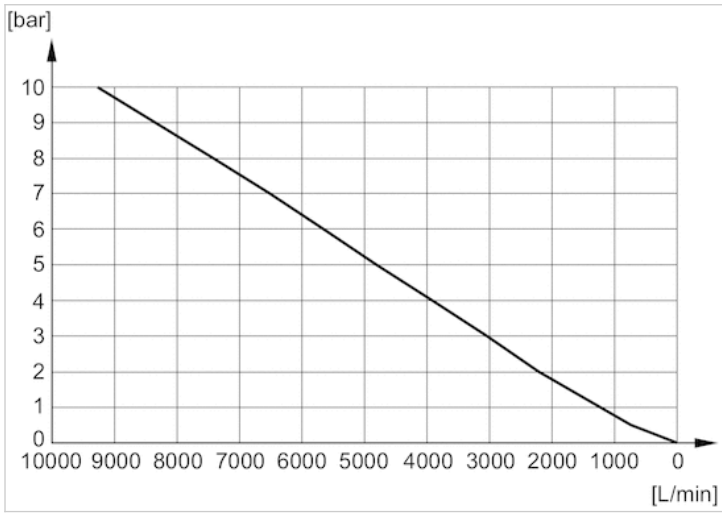

Flow diagram, R412010085

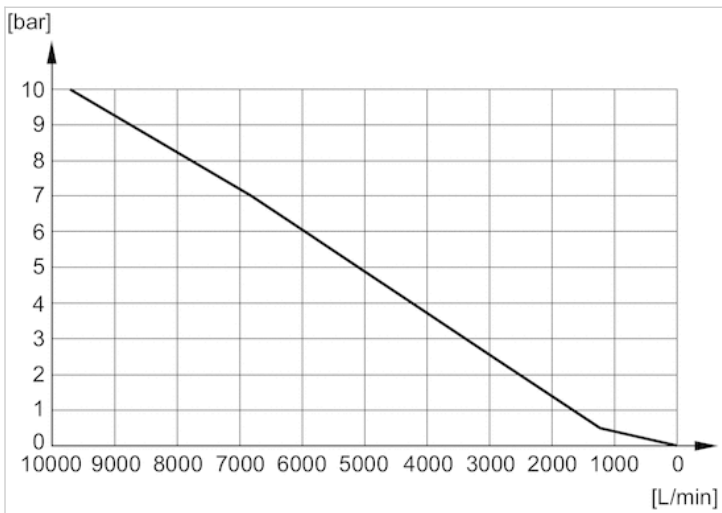

Flow diagram, R412010086

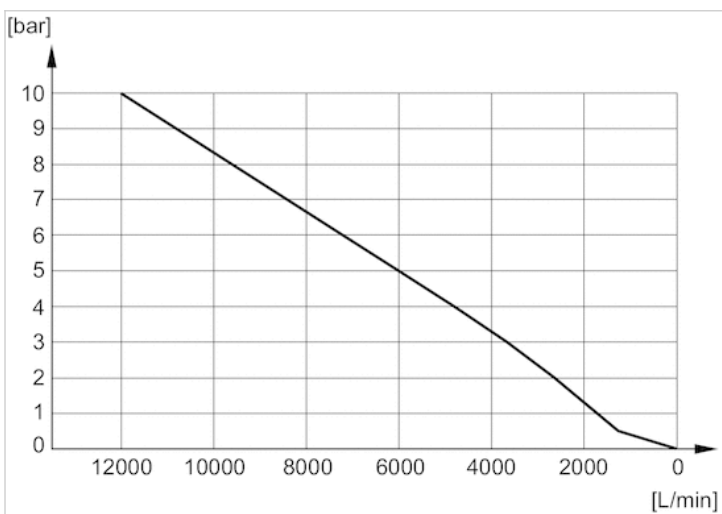

Efficient pneumatic solutions, our program: cylinders and drives, valves and valve systems, air supply management



Visit us: [Emerson.com/Aventics](https://www.emerson.com/Aventics)

Your local contact: [Emerson.com/contactus](https://www.emerson.com/contactus)



[Emerson.com](https://www.emerson.com)



[Facebook.com/EmersonAutomationSolutions](https://www.facebook.com/EmersonAutomationSolutions)



[LinkedIn.com/company/Emerson-Automation-Solutions](https://www.linkedin.com/company/Emerson-Automation-Solutions)



[Twitter.com/EMR_Automation](https://twitter.com/EMR_Automation)

An example configuration is depicted on the title page. The delivered product may thus vary from that in the illustration. Subject to change. This Document, as well as the data, specifications and other information set forth in it, are the exclusive property of AVENTICS GmbH. It may not be reproduced or given to third parties without its consent. Only use the AVENTICS products shown in industrial applications. Read the product documentation completely and carefully before using the product. Observe the applicable regulations and laws of the respective country. When integrating the product into applications, note the system manufacturer's specifications for safe use of the product. The data specified only serve to describe the product. No statements concerning a certain condition or suitability for a certain application can be derived from our information. The information given does not release the user from the obligation of own judgment and verification. It must be remembered that the products are subject to a natural process of wear and aging.

The Emerson logo is a trademark and service mark of Emerson Electric Co. Brand logotype are registered trademarks of one of the Emerson family of companies. All other marks are the property of their respective owners. © 2017 Emerson Electric Co. All rights reserved.
2019-03



CONSIDER IT SOLVED™