



CMFC-9000 Series

Coriolis Mass Flow Controller

For Slurries and Chemicals

Description

The CMFC-9000 Series is a line of high-performance closed-loop flow controllers designed for use in a wide variety of high-purity liquids including DI water, harsh chemicals, and CMP polishing slurries.

A typical flow control module consists of a high-accuracy, advanced Coriolis flow-meter with a Malema control valve. The Coriolis flow-meter has an all PFA construction with no moving parts or seals. It sets a standard for flow measurement in terms of accuracy and repeatability. The Coriolis flow measurement technology with its advanced digital signal processing ensures reliable performance even for process fluids with entrapped gases. The high speed/precision motor actuated pinch valve (for slurries) or diaphragm valve (for chemicals) helps provide a fast and precise response with minimal “overshoot”. Its all PTFE (Polytetrafluoroethylene) construction and minimal dead volume ensure maximum process purity and reliability (chemical control valve).

In operation, the user inputs a set-point via an analog signal. The flow control module’s electronics continuously compares this set point value with the flow rate reported by the flow meter and provides a continuous feedback signal to modulate the control valve to maintain the desired set point. The state of the art control algorithm together with high speed/precision flow meter and valve achieves fast, accurate, and repeatable control.

Applications

- Semiconductor CMP tools - used to precisely control the flow of chemicals and polishing slurries dispensed to the polishing platen; an ideal replacement for peristaltic pump based delivery systems.
- Wet Cleaning tools – for accurate and reliable control of the blending and delivery of cleaning chemistries.
- Copper Plating tools – well suited to chemical mixing and dispensing applications.

Key Features

- **High Accuracy - Controls flow-rate to within $\pm 1.5\%$ of set-point; ideal for fluid blending and/or dispense applications**
- **Fast Response 2 seconds (typically <1 seconds for most applications)**
- **Broad application range with 2 types of control valves**
- **Wide range of flow control capability**
- **All PTFE/PFA wetted part construction – compatible with UHP liquid chemicals, DI water and CMP slurries (slurry module with Pt cured Silicone tubing)**
- **Mass flow measurement accuracy is independent of fluid density and viscosity**

Performance Specifications

Flow Range	20 – 100 g/min *
	25 – 250 g/min
	50 – 500 g/min
	100 – 1000 g/min
	150 – 1500 g/min
	200 – 2000 g/min
	250 – 2500 g/min
	300 – 3000 g/min
	400 – 4000 g/min
Accuracy ** (for room temperature DIW)	±1.5% of set point or ±3 g/min (whichever is larger)
Control Repeatability	± 0.5% of set point or ± 0.5 g/min (whichever is larger)
Flow Control Time	< 2 sec (< 1 sec for most applications)
Fluid Temperature	18 – 50 °C ***
Ambient: Temperature/Humidity	0 – 40 °C / 30 – 80% RH, without Dew
Maximum Expected Operating Pressure	50 psig
Maximum Safe Internal Pressure	70 psig

- * Under development; consult factory
- ** Please consult with Malema for tighter accuracy needs.
- *** Consult the factory for higher temperature application

Material Specifications

Wetted parts	PFA high purity, PTFE, Pt cured Silicone*
Non Wetted Parts, Enclosure	PPS, PEEK, Acrylic, Vinyl, PVC**, PC, PP, PVDF, Aluminum 6061 T6 (anodized), Stainless Steel (passivated)

- * Only used in the Slurry Module
- ** Flame retardant (FMET4325)

Electrical Specifications

Power Supply Input	24 V DC ± 10%
Power Consumption	6W ~ 250 mA @ 24 V DC
Alarm Signals	Max 30 V DC, 200 mA NPN open collector
Control Signal In *	0–5 V DC, 0–10 V DC, or 4–20 mA
Flow Signal Out *	0–5 V DC, 0–10 V DC, or 4–20 mA

- * Consult factory for other options

Physical Specifications

Mounting Orientation	Horizontal or Vertical
Fluid Connections	Inlet/Outlet: 1/4" or 3/8", Flare or Pillar
Flow Restrictions (orifice)	> 2 mm
Ingress Rating	IP64

Power and Signal Connections (Typical)

(Refer to specific product drawing for custom part numbers)

It is always recommended to use a dedicated power supply with 24 Vdc ($\pm 10\%$), 500mA.

The configuration of the 3 connectors and their mating cables is given in the table below. A USB communication cable can be ordered separately to interface with the PC GUI program.

3-cable Connector Configuration				
Cable	Pin No.	Wire Color	Description	Specification
Power Supply (P1)	1	Brown	N.C.	24 V DC $\pm 10\%$
	2	White	Power (+) 24 V DC	
	3	Blue	N.C.	
	4	Black	Power (-) 0 V DC	
Set Point (P2)	1	Brown	N.C.	4–20 mA, 0–10 V DC, or 0–5 V DC
	3	Blue	Set Flow Ground (-)	
	4	Black	Set Flow Input (+)	
Flow Rate (J3)	1	Brown	N.C.	4–20 mA, 0–10 V DC, or 0–5 V DC
	3	Blue	Flow Rate Ground (-)	
	4	Black	Flow Rate Output (+)	

Typical Block Diagram

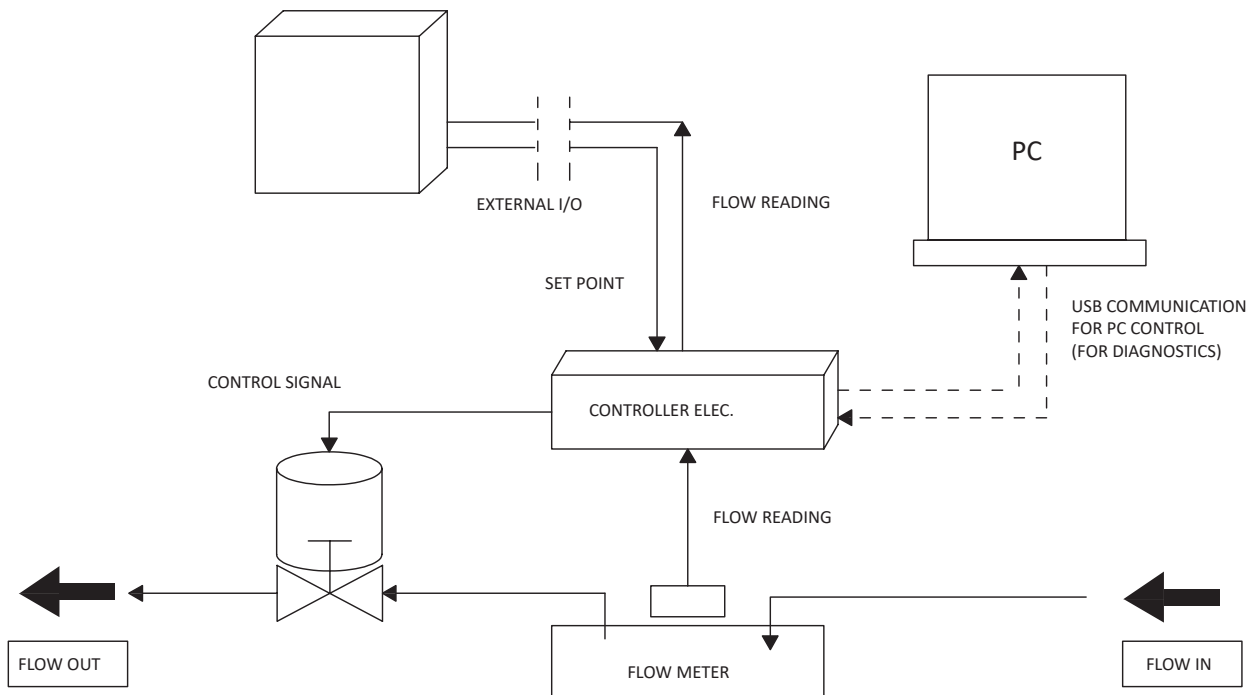

Dimensional Drawing (Typical Horizontal Modules)

1/4" Flare inlet/outlet

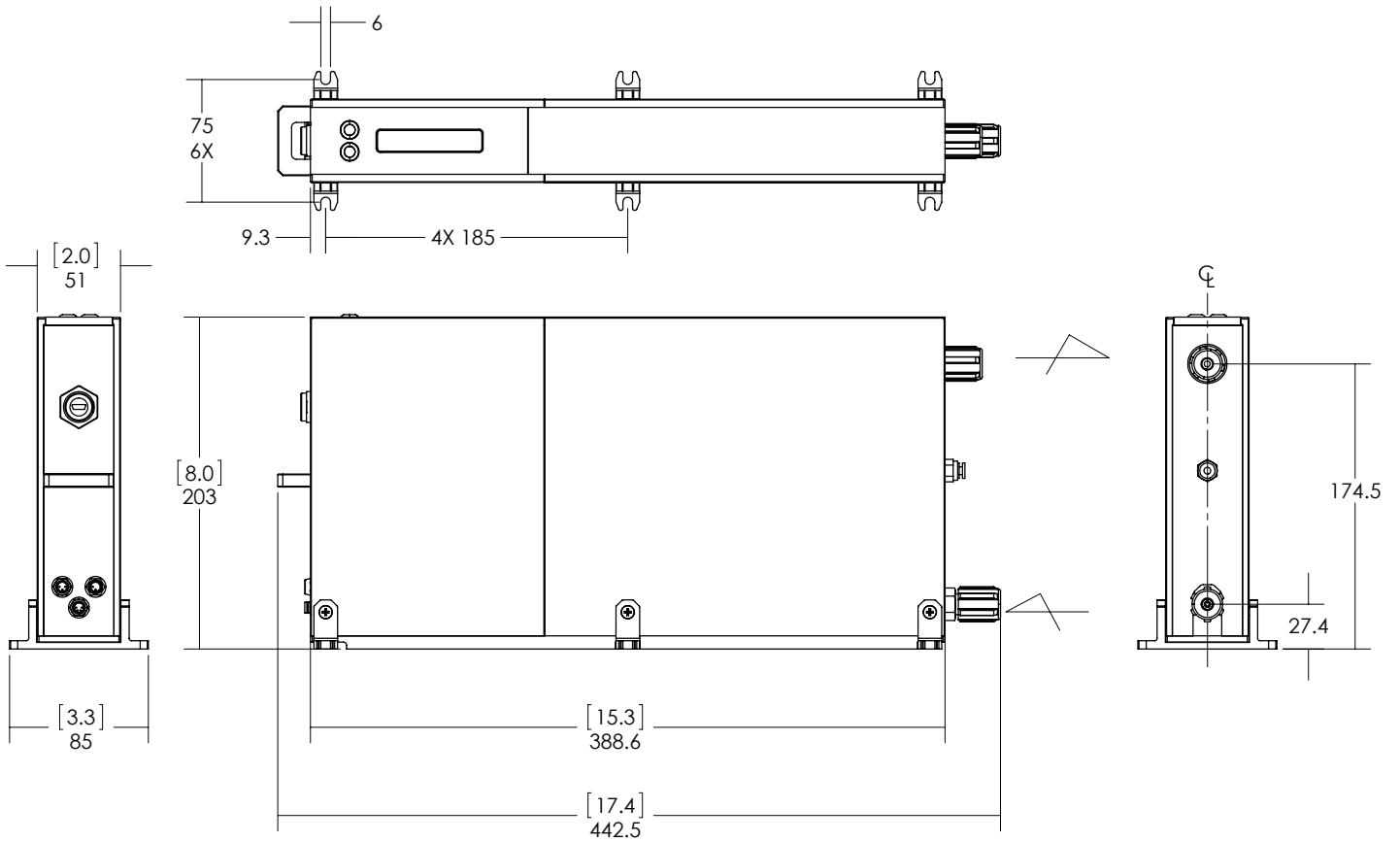

Ordering Information

Model Code														Description
CMFC-9	***	-	*	*	*	**	-	*	*	-	*	*	-	
Sensor	031													3 mm serial
	032													3 mm parallel
	-													
Material	F													PFA
Tube Size	2													1/4"
	3													3/8"
Connection Type	1													Tube ends
	2													Flare
	3													Super Pillar 300
	02													20 – 100 g/min *
	03													25– 250 g/min
	04													50 – 500 g/min
	05													100 – 1000 g/min
	06													150 – 1500 g/min
	07													200 – 2000 g/min
	08													250 – 2500 g/min
	09													300 – 3000 g/min
	10													400 – 4000 g/min
		-												
Input (Set Point)	1													Current (4–20 mA)
	2													Voltage (0–10 V DC)
	3													Voltage (0–5 V DC)
Output (Flow Rate)	1													Current (4–20 mA)
	2													Voltage (0–10 V DC)
	3													Voltage (0–5 V DC)
	-													
Valve Type	N													Diaphragm Valve
	P													Pinch Valve
Mounting Orientation	H													Horizontal
	-	XXX												Unique PN Identifier

* Available on request; consult factory

© 2022 Malema Engineering Corporation. All rights reserved.

Malema Sensors is a registered trademark of Malema Engineering Corporation. Malema Engineering Corporation, Malema, and the Malema logo are trademarks of Malema Engineering Corporation. All other trademarks are property of their respective owners.

Malema supplies this publication for informational purposes only. While every effort has been made to ensure accuracy, this publication is not intended to make performance claims or process recommendations. Malema does not warrant, guarantee, or assume any legal liability for the accuracy, completeness, timeliness, reliability, or usefulness of any information, product, or process described herein. We reserve the right to modify or improve the designs or specifications of our products at any time without notice. For actual product information and recommendations, please contact your local Malema representative.

Corporate Headquarters

1060 S Rogers Circle
 Boca Raton, FL 33487
 P: (561) 995-0595 F: (561) 995-0622

West Coast Headquarters

2329 Zanker Road
 San Jose, CA 95131
 P: (408) 970-3419 F: (408) 970-3426

Asia Pacific Headquarters

35 Marsiling Industrial Estate Road 3 #02-06
 Singapore 739257
 P: (65) 6482-3533 F: (65) 6484-4231