

## ISO 15552, series ITS



AVENTICS™ ISO 15552, series ITS



# Tie rod cylinder ISO 15552, Series ITS

- Ø 160-320 mm
- Ports G 3/4 G 1
- double-acting
- with magnetic piston
- Cushioning pneumatically adjustable
- Piston rod External thread
- ATEX optional



Standards	ISO 15552
Certificates	ATEX optional
Compressed air connection	Internal thread
Working pressure min./max.	2 ... 10 bar
Ambient temperature min./max.	-20 ... 80 °C
Medium temperature min./max.	-20 ... 80 °C
Medium	Compressed air
Max. particle size	50 µm
Oil content of compressed air	0 ... 5 mg/m <sup>3</sup>
Pressure for determining piston forces	6.3 bar

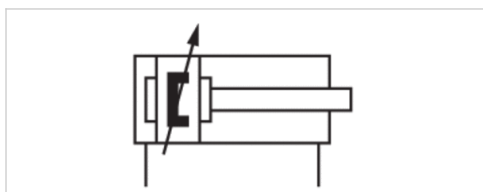

## Technical data

Piston Ø Piston rod thread Ports Piston rod Ø	160 mm M36x2 G 3/4 40 mm	200 mm M36x2 G 3/4 40 mm	250 mm M42x2 G 1 50 mm	320 mm M48x2 G 1 63 mm
Stroke 25	R480627295	R480627367	R480627451	R480627463
50	R480627296	R480627368	R480627452	R480630857
80	R480627297	R480627369	R480627453	R480627465
100	R480627298	R480627370	R480627454	R480627466
125	R480627299	R480627371	R480627455	R480627467
160	R480627300	R480627372	R480627456	R480627468
200	R480627301	R480627373	R480627457	R480627469
250	R480627302	R480627374	R480627458	R480627470
320	R480627303	R480627375	R480627459	R480627471
400	R480627304	R480627376	R480627460	R480627472
500	R480627305	R480627377	R480627461	R480627473

## Technical data

Piston Ø	160 mm	200 mm	250 mm	320 mm
Retracting piston force	11875 N	19000 N	29688 N	48704 N
Extracting piston force	12667 N	19792 N	30925 N	50668 N
Cushioning length	46 mm	46 mm	56 mm	56 mm
Cushioning energy	160 J	170 J	180 J	190 J
Weight 0 mm stroke	12.5 kg	15.67 kg	25.87 kg	46.89 kg
Weight +10 mm stroke	0.21 kg	0.21 kg	0.38 kg	0.61 kg
Stroke max.	2700 mm	2700 mm	2500 mm	2500 mm

## Technical information

The pressure dew point must be at least 15 °C under ambient and medium temperature and may not exceed 3 °C .

The oil content of compressed air must remain constant during the life cycle.

Use only the approved oils from AVENTICS. Further information can be found in the "Technical information" document (available in the MediaCentre).

Clamping piece for magnetic field sensor necessary

ATEX-certified cylinders with identification II 2G Ex h IIB T4 Gb / II 2D Ex h IIIB T135°C Db\_X can be generated in the Internet configurator.

## Technical information

Material	
Cylinder tube	Aluminum, anodized
Piston rod	Stainless steel
Front cover	Die-cast aluminum
End cover	Die-cast aluminum
Seal	Acrylonitrile butadiene rubber
Nut for piston rod	Steel, galvanized
Scraper	Acrylonitrile butadiene rubber
Tie-rods	Stainless steel

## Dimensions

### Dimensions

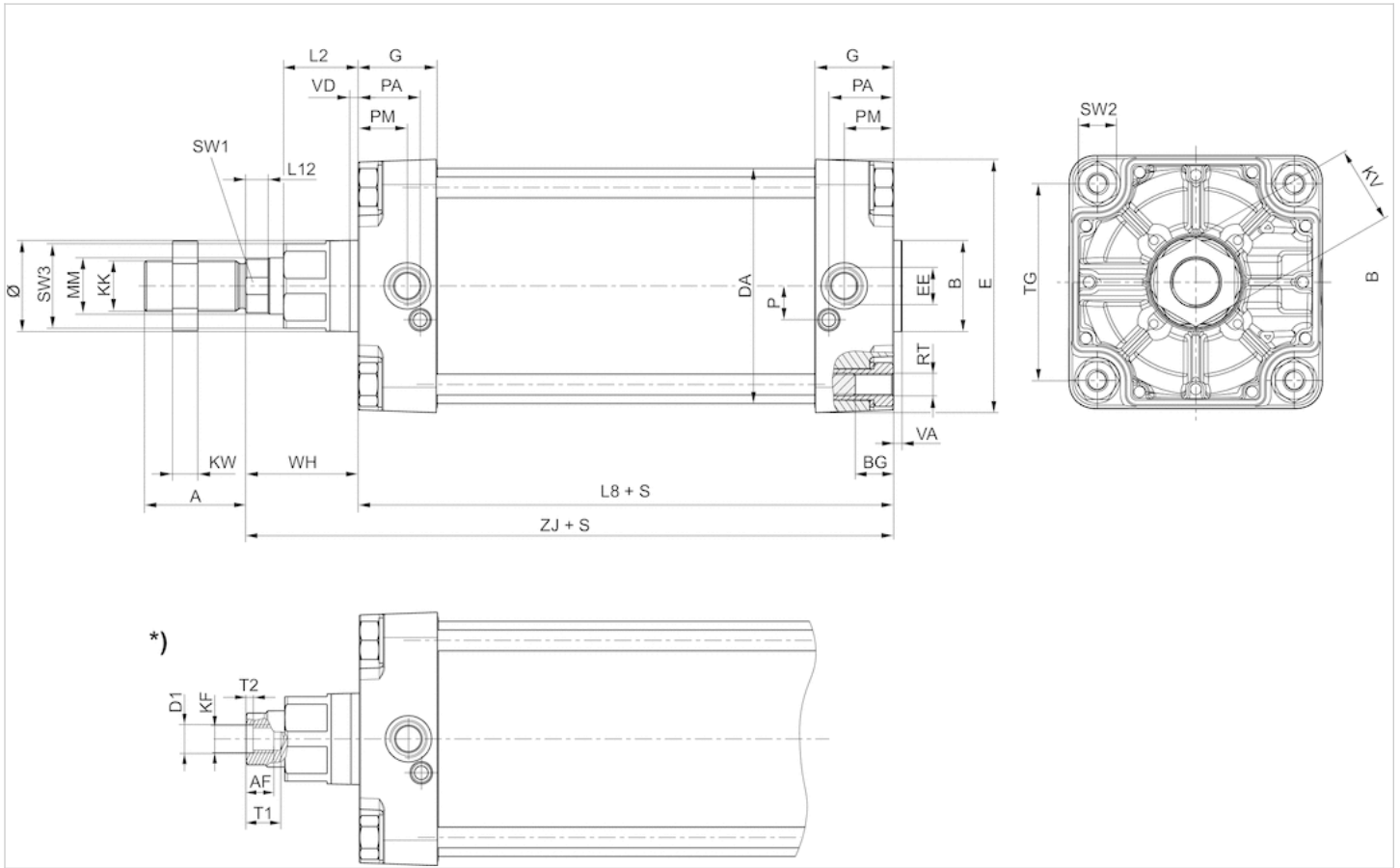

S = stroke

\*) For cylinders with optional piston rod with internal thread

## Dimensions

Piston Ø	A	AF	B	ØB	BG	D1	DA	E	EE	G	KF	KK	KV	KW	L2	L8	L12	MM	P	PA
160 mm	72	36	65	65	24	25	167	180	G 3/4	56	M24	M36x2	55	18	53	180	16	40	24	45
200 mm	72	36	75	75	24	25	210	220	G 3/4	54	M24	M36x2	55	18	56	180	16	40	22.5	42
250 mm	84	50	90	90	25	31	262	280	G 1	59.5	M30	M42x2	65	21	67	200	20	50	29	46
320 mm	96	55	110	110	28	37	336	350	G 1	61.5	M36	M48x2	75	24	76	220	23.25	63	30	48

Piston Ø	PM	RT	SW1	SW2	SW3	T1	T2	TG	VA	VD	WH	ZJ
160 mm	35	M16	36	27	60	40	10	140	6	6	80	260
200 mm	30	M16	36	27	60	40	10	175	6	6	95	275
250 mm	32.8	M20	46	41	80	60	10	220	10	31	105	305.3
320 mm	37	M24	55	50	95	65	13	270	10	34	120	340.5

# Diagrams

## Cushioning diagram

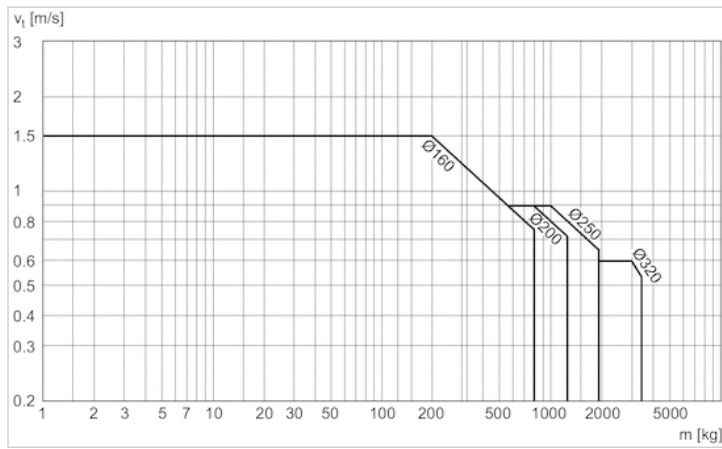

v = Piston velocity [m/s]  
 m = Cushionable mass [kg]

# Accessories overview

## Overview drawing

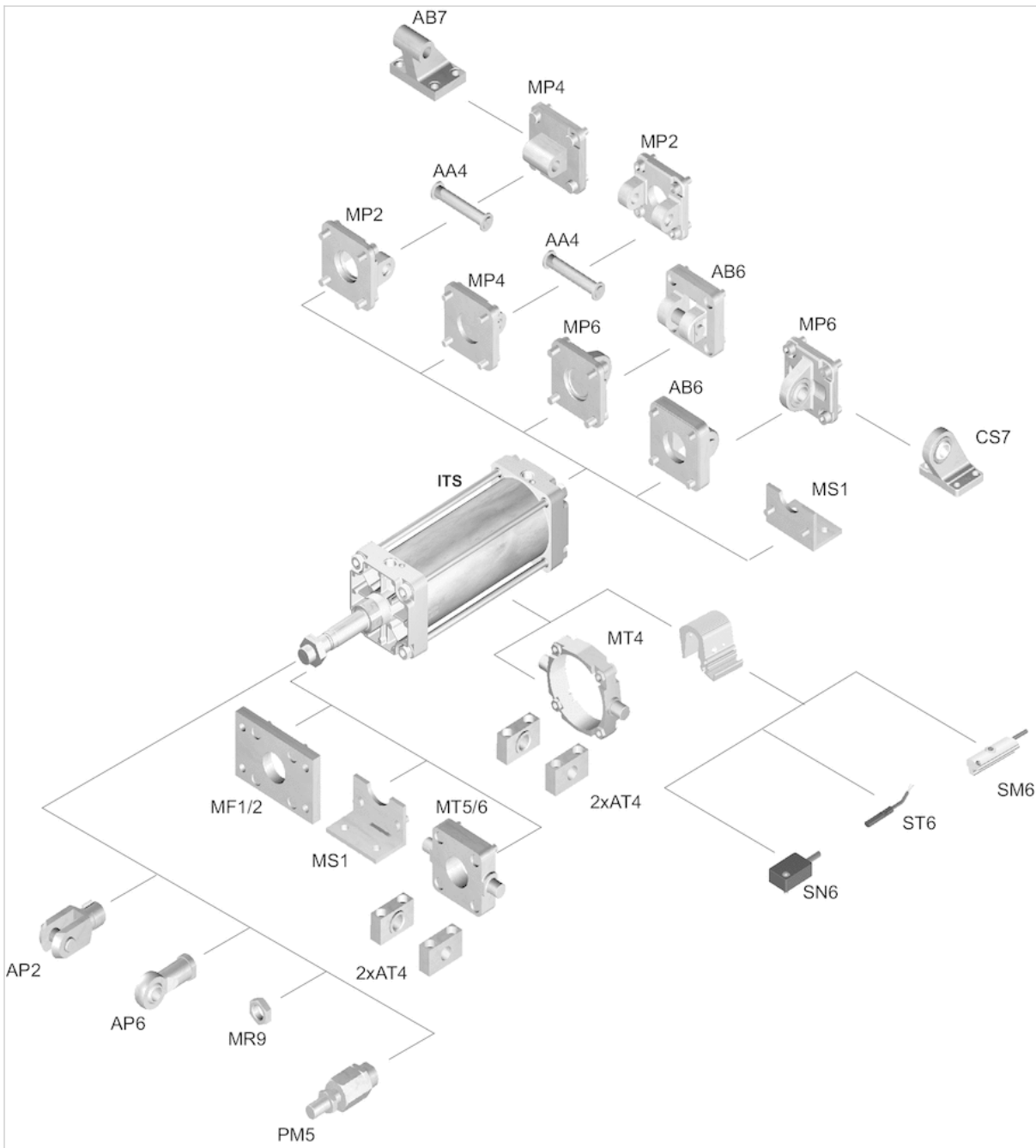

**NOTE:**

This overview drawing is only for orientation to indicate where the various accessory parts can be fastened to the cylinder. The illustration has been simplified for this purpose. It is thus not possible to derive the dimensions from this overview.

# Tie rod cylinder ISO 15552, Series ITS

- Ø 160-320 mm
- Ports G 3/4 G 1
- double-acting
- Cushioning pneumatically adjustable
- Piston rod External thread
- ATEX optional

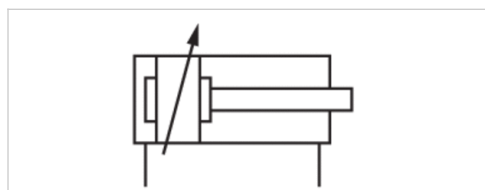

Standards	ISO 15552
Certificates	ATEX optional
Compressed air connection	Internal thread
Working pressure min./max.	2 ... 10 bar
Ambient temperature min./max.	-20 ... 80 °C
Medium temperature min./max.	-20 ... 80 °C
Medium	Compressed air
Max. particle size	50 µm
Oil content of compressed air	0 ... 5 mg/m <sup>3</sup>
Pressure for determining piston forces	6.3 bar

## Technical data

Piston Ø Piston rod thread Ports Piston rod Ø	160 mm M36x2 G 3/4 40 mm	200 mm M36x2 G 3/4 40 mm	250 mm M42x2 G 1 50 mm	320 mm M48x2 G 1 63 mm
Stroke 25	R480627283	R480627355	R480627427	R480627439
50	R480627284	R480627356	R480627428	R480627440
80	R480627285	R480627357	R480627429	R480627441
100	R480627286	R480627358	R480627430	R480627442
125	R480627287	R480627359	R480627431	R480627443
160	R480627288	R480627360	R480627432	R480627444
200	R480627289	R480627361	R480627433	R480627445
250	R480627290	R480627362	R480627434	R480627446
320	R480627291	R480627363	R480627435	R480627447
400	R480627292	R480627364	R480627436	R480627448
500	R480627293	R480627365	R480627437	R480627449

## Technical data

Piston Ø	160 mm	200 mm	250 mm	320 mm
Retracting piston force	11875 N	19000 N	29688 N	48704 N
Extracting piston force	12667 N	19792 N	30925 N	50668 N
Cushioning length	46 mm	46 mm	56 mm	56 mm
Cushioning energy	160 J	170 J	180 J	190 J
Weight 0 mm stroke	12.5 kg	15.67 kg	25.87 kg	46.89 kg
Weight +10 mm stroke	0.21 kg	0.21 kg	0.38 kg	0.61 kg
Stroke max.	2700 mm	2700 mm	2500 mm	2500 mm

## Technical information

The pressure dew point must be at least 15 °C under ambient and medium temperature and may not exceed 3 °C .

The oil content of compressed air must remain constant during the life cycle.

Use only the approved oils from AVENTICS. Further information can be found in the "Technical information" document (available in the MediaCentre).

ATEX-certified cylinders with identification II 2G Ex h IIB T4 Gb / II 2D Ex h IIIB T135°C Db\_X can be generated in the Internet configurator.

## Technical information

Material	
Cylinder tube	Aluminum, anodized
Piston rod	Stainless steel
Front cover	Die-cast aluminum
End cover	Die-cast aluminum
Seal	Acrylonitrile butadiene rubber
Nut for piston rod	Steel, galvanized
Scraper	Acrylonitrile butadiene rubber
Tie-rods	Stainless steel



# Dimensions

## Dimensions

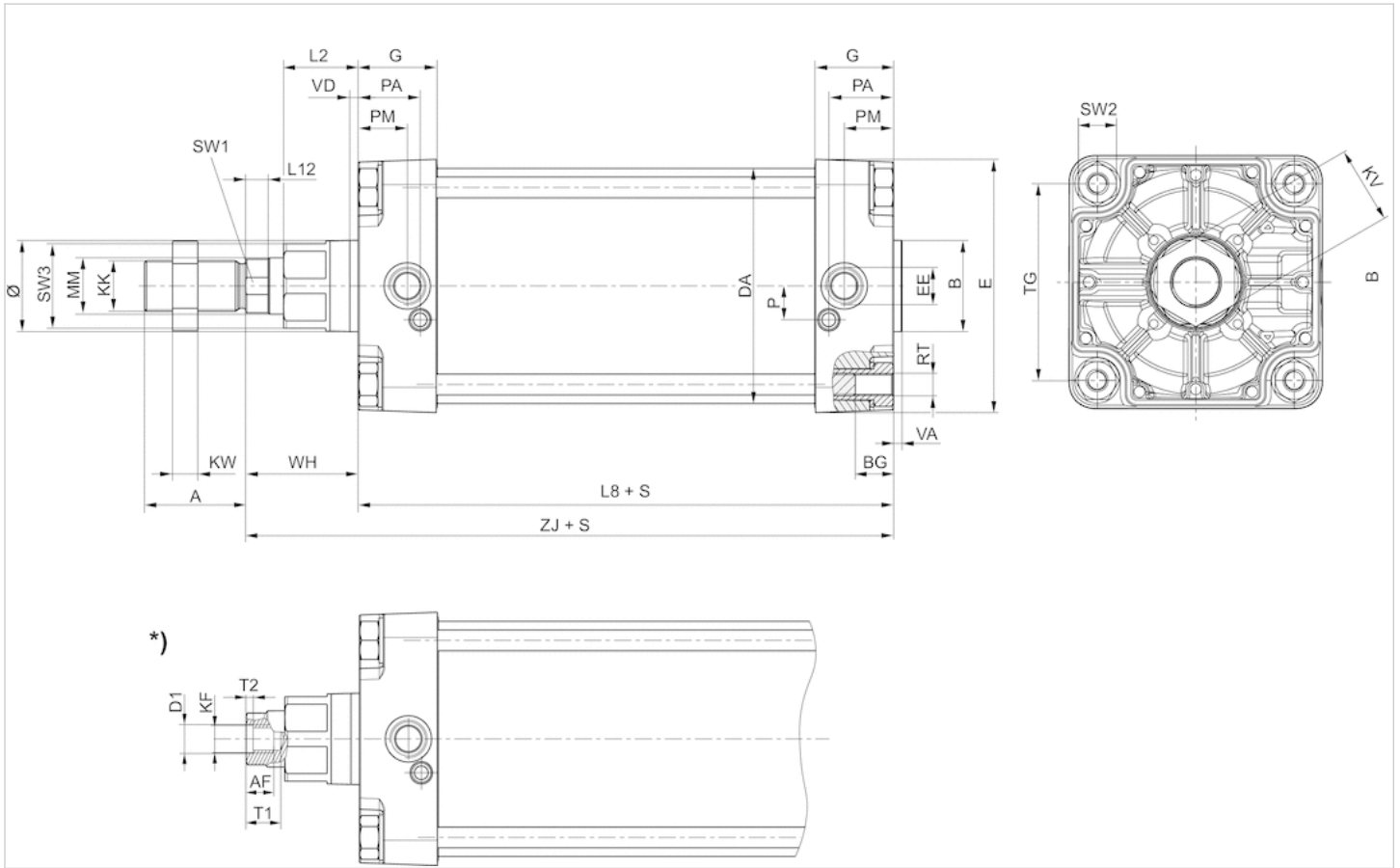

S = stroke

\*) For cylinders with optional piston rod with internal thread

# Dimensions

Piston Ø	A	B	ØB	BG	DA	E	EE	G	KK	KV	KW	L2	L8	L12	MM	P	PA	PM	RT
160 mm	72	65	65	24	167	180	G 3/4	56	M36x2	55	18	53	180	16	40	24	45	35	M16
200 mm	72	75	75	24	210	220	G 3/4	54	M36x2	55	18	56	180	16	40	22.5	42	30	M16
250 mm	84	90	90	25	262	280	G 1	59.5	M42x2	65	21	67	200	20	50	29	46	32.8	M20
320 mm	96	110	110	28	336	350	G 1	61.5	M48x2	75	24	76	220	23.25	63	30	48	37	M24

Piston Ø	SW1	SW2	SW3	TG	VA	VD	WH	ZJ
160 mm	36	27	60	140	6	6	80	260
200 mm	36	27	60	175	6	6	95	275
250 mm	46	41	80	220	10	31	105	305.3
320 mm	55	50	95	270	10	34	120	340.5

# Diagrams

## Cushioning diagram

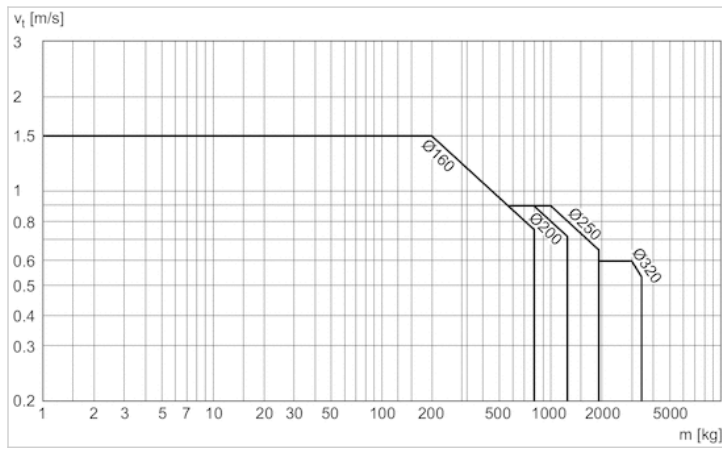

v = Piston velocity [m/s]  
 m = Cushionable mass [kg]

# Accessories overview

## Overview drawing

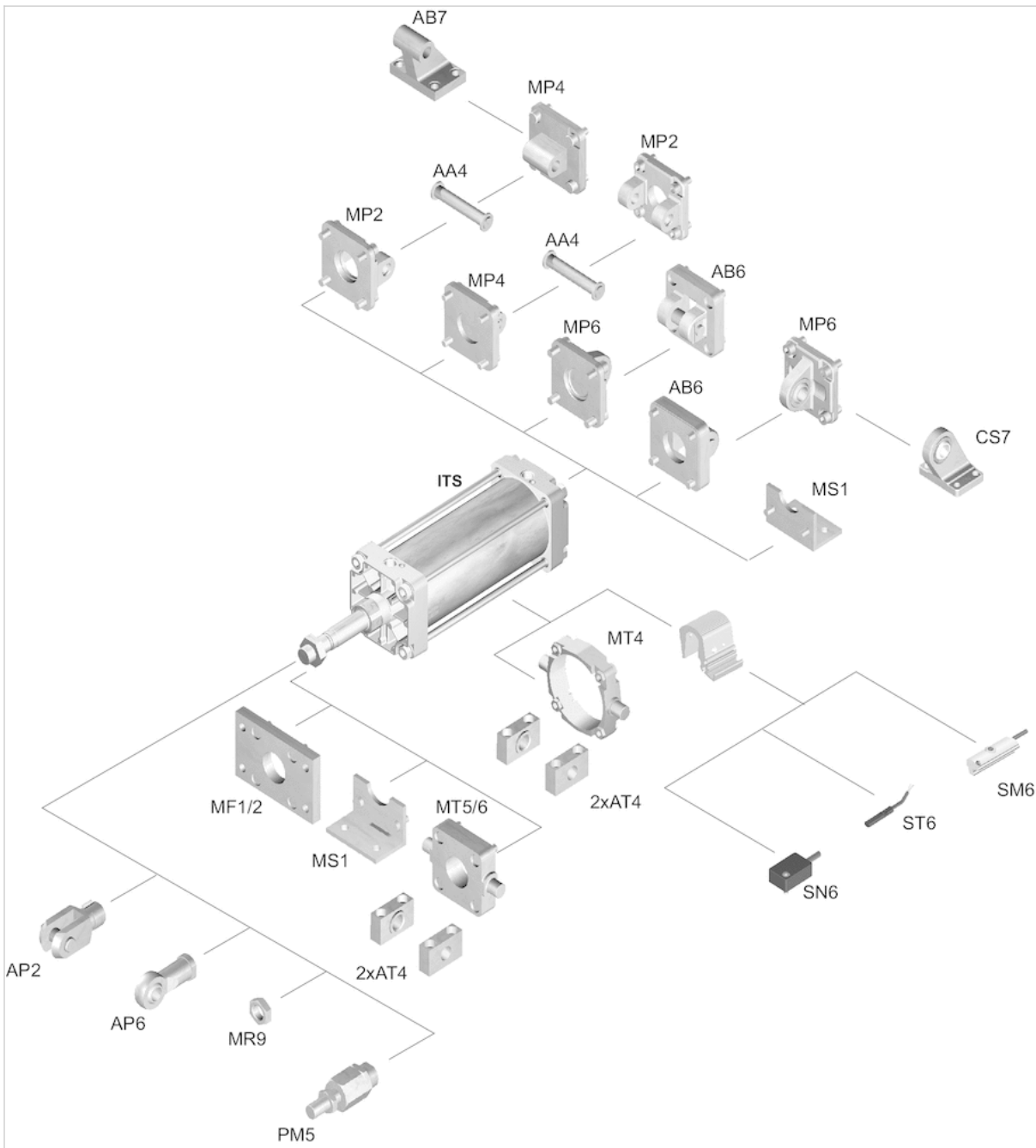

**NOTE:**

This overview drawing is only for orientation to indicate where the various accessory parts can be fastened to the cylinder. The illustration has been simplified for this purpose. It is thus not possible to derive the dimensions from this overview.

# Tie rod cylinder ISO 15552, Series ITS

- Ø 160-320 mm
- Ports G 3/4 G 1
- double-acting
- with magnetic piston
- Cushioning elastic, elastic
- Piston rod External thread
- ATEX optional



Standards	ISO 15552
Certificates	ATEX optional
Compressed air connection	Internal thread
Working pressure min./max.	2 ... 10 bar
Ambient temperature min./max.	-20 ... 80 °C
Medium temperature min./max.	-20 ... 80 °C
Medium	Compressed air
Max. particle size	50 µm
Oil content of compressed air	0 ... 5 mg/m <sup>3</sup>
Pressure for determining piston forces	6.3 bar



## Technical data

Piston Ø Piston rod thread Ports Piston rod Ø	160 mm M36x2 G 3/4 40 mm	200 mm M36x2 G 3/4 40 mm	250 mm M42x2 G 1 50 mm	320 mm M48x2 G 1 63 mm
Stroke 25	R480635034	R480627583	R480627595	R480627607
50	R480627572	R480627584	R480627596	R480627608
80	R480627573	R480627585	R480627597	R480627609
100	R480627574	R480627586	R480627598	R480627610
125	R480627575	R480627587	R480627599	R480627611
160	R480627576	R480627588	R480627600	R480627612
200	R480635134	R480627589	R480627601	R480627613
250	R480627578	R480627590	R480627602	R480627614
320	R480627579	R480627591	R480627603	R480627615
400	R480627580	R480627592	R480627604	R480627616
500	R480627581	R480627593	R480627605	R480627617

## Technical data

Piston Ø	160 mm	200 mm	250 mm	320 mm
Retracting piston force	11875 N	19000 N	29688 N	48704 N
Extracting piston force	12667 N	19792 N	30925 N	50668 N
Impact energy	10 J	15 J	24 J	39 J
Weight 0 mm stroke	12.5 kg	15.67 kg	25.87 kg	46.89 kg
Weight +10 mm stroke	0.21 kg	0.21 kg	0.38 kg	0.61 kg
Stroke max.	2700 mm	2700 mm	2500 mm	2500 mm

The cushioning diagram can be found in the "Technical information" document (available in the MediaCentre).

## Technical information

The pressure dew point must be at least 15 °C under ambient and medium temperature and may not exceed 3 °C .

The oil content of compressed air must remain constant during the life cycle.

Use only the approved oils from AVENTICS. Further information can be found in the "Technical information" document (available in the MediaCentre).

Clamping piece for magnetic field sensor necessary

ATEX-certified cylinders with identification II 2G Ex h IIB T4 Gb / II 2D Ex h IIIB T135°C Db\_X can be generated in the Internet configurator.

## Technical information

Material	
Cylinder tube	Aluminum, anodized
Piston rod	Stainless steel
Front cover	Die-cast aluminum
End cover	Die-cast aluminum
Seal	Acrylonitrile butadiene rubber
Nut for piston rod	Steel, galvanized
Scraper	Acrylonitrile butadiene rubber
Tie-rods	Stainless steel

## Dimensions

### Dimensions

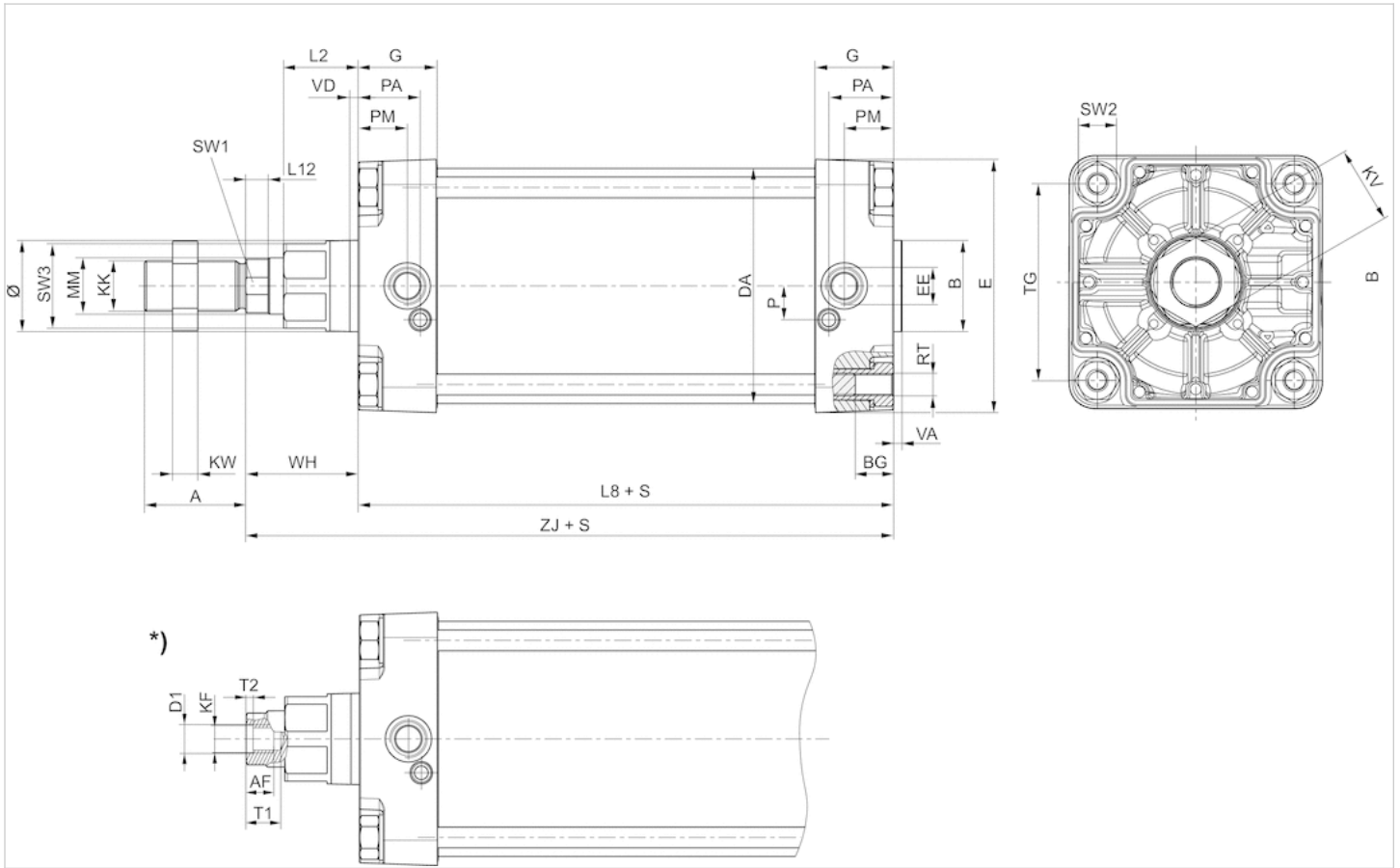

S = stroke

\*) For cylinders with optional piston rod with internal thread

## Dimensions

Piston Ø	A	B	ØB	BG	DA	E	EE	G	KK	KV	KW	L2	L8	L12	MM	P	PA	PM	RT
160 mm	72	65	65	24	167	180	G 3/4	56	M36x2	55	18	53	180	16	40	24	45	35	M16
200 mm	72	75	75	24	210	220	G 3/4	54	M36x2	55	18	56	180	16	40	22.5	42	30	M16
250 mm	84	90	90	25	262	280	G 1	59.5	M42x2	65	21	67	200	20	50	29	46	32.8	M20
320 mm	96	110	110	28	336	350	G 1	61.5	M48x2	75	24	76	220	23.25	63	30	48	37	M24

Piston Ø	SW1	SW2	SW3	TG	VA	VD	WH	ZJ
160 mm	36	27	60	140	6	6	80	260
200 mm	36	27	60	175	6	6	95	275
250 mm	46	41	80	220	10	31	105	305.3
320 mm	55	50	95	270	10	34	120	340.5

# Accessories overview

## Overview drawing

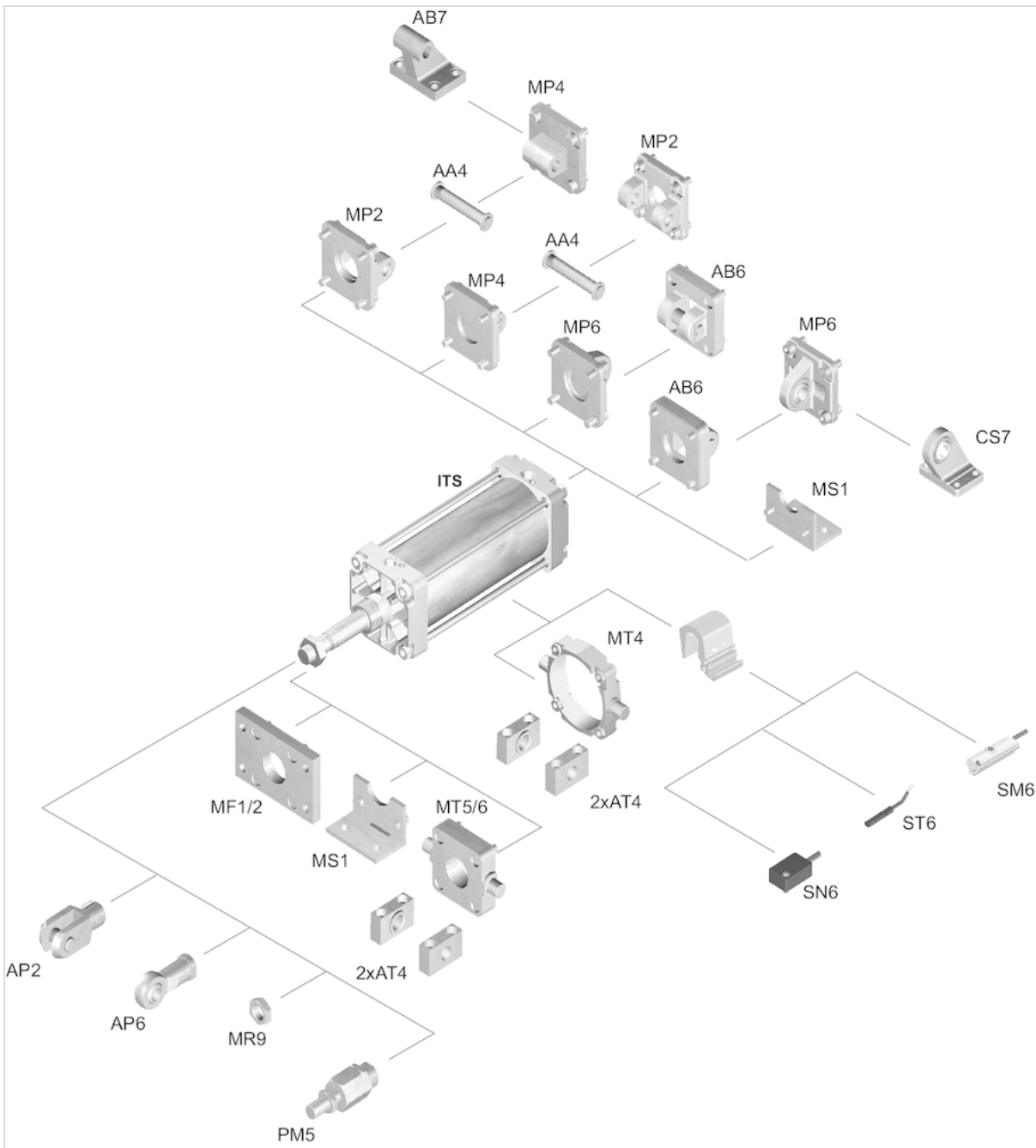

**NOTE:**

This overview drawing is only for orientation to indicate where the various accessory parts can be fastened to the cylinder. The illustration has been simplified for this purpose. It is thus not possible to derive the dimensions from this overview.

# Tie rod cylinder ISO 15552, Series ITS

- Ø 160-320 mm
- Ports G 3/4 G 1
- double-acting
- Cushioning elastic
- Piston rod External thread
- ATEX optional



Standards	ISO 15552
Certificates	ATEX optional
Compressed air connection	Internal thread
Working pressure min./max.	2 ... 10 bar
Ambient temperature min./max.	-20 ... 80 °C
Medium temperature min./max.	-20 ... 80 °C
Medium	Compressed air
Max. particle size	50 µm
Oil content of compressed air	0 ... 5 mg/m <sup>3</sup>
Pressure for determining piston forces	6.3 bar

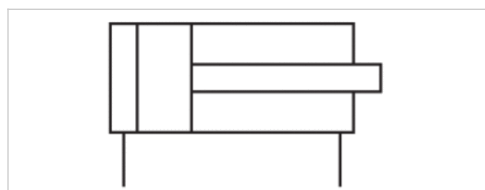

## Technical data

Piston Ø Piston rod thread Ports Piston rod Ø	160 mm M36x2 G 3/4 40 mm	200 mm M36x2 G 3/4 40 mm	250 mm M42x2 G 1 50 mm	320 mm M48x2 G 1 63 mm
Stroke 25	R480635020	R480627679	R480627691	R480627703
50	R480627668	R480627680	R480627692	R480627704
80	R480627669	R480627681	R480627693	R480627705
100	R480627670	R480627682	R480627694	R480627706
125	R480627671	R480627683	R480627695	R480627707
160	R480627672	R480627684	R480627696	R480627708
200	R480627673	R480627685	R480627697	R480627709
250	R480627674	R480627686	R480627698	R480627710
320	R480627675	R480627687	R480627699	R480627711
400	R480627676	R480627688	R480627700	R480627712
500	R480627677	R480627689	R480627701	R480627713



## Technical data

Piston Ø	160 mm	200 mm	250 mm	320 mm
Retracting piston force	11875 N	19000 N	29688 N	48704 N
Extracting piston force	12667 N	19792 N	30925 N	50668 N
Impact energy	10 J	15 J	24 J	39 J
Weight 0 mm stroke	12.5 kg	15.67 kg	25.87 kg	46.89 kg
Weight +10 mm stroke	0.21 kg	0.21 kg	0.38 kg	0.61 kg
Stroke max.	2700 mm	2700 mm	2500 mm	2500 mm

## Technical information

The pressure dew point must be at least 15 °C under ambient and medium temperature and may not exceed 3 °C .

The oil content of compressed air must remain constant during the life cycle.

Use only the approved oils from AVENTICS. Further information can be found in the "Technical information" document (available in the MediaCentre).

ATEX-certified cylinders with identification II 2G Ex h IIB T4 Gb / II 2D Ex h IIIB T135°C Db\_X can be generated in the Internet configurator.

## Technical information

Material	
Cylinder tube	Aluminum, anodized
Piston rod	Stainless steel
Front cover	Die-cast aluminum
End cover	Die-cast aluminum
Seal	Acrylonitrile butadiene rubber
Nut for piston rod	Steel, galvanized
Scraper	Acrylonitrile butadiene rubber
Tie-rods	Stainless steel

## Dimensions

### Dimensions

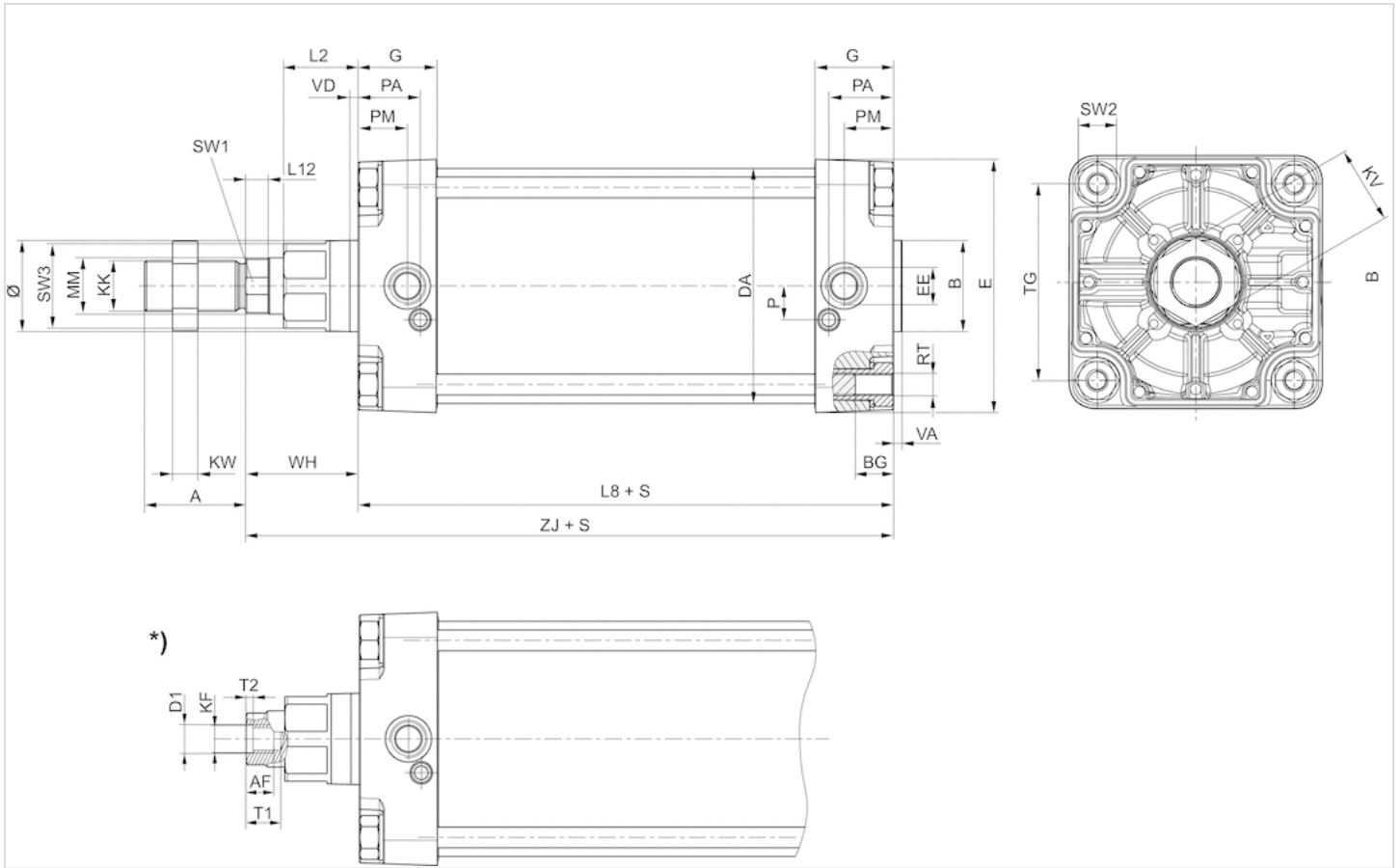

S = stroke

\*) For cylinders with optional piston rod with internal thread

## Dimensions

Piston Ø	A	B	ØB	BG	DA	E	EE	G	KK	KV	KW	L2	L8	L12	MM	P	PA	PM	RT
160 mm	72	65	65	24	167	180	G 3/4	56	M36x2	55	18	53	180	16	40	24	45	35	M16
200 mm	72	75	75	24	210	220	G 3/4	54	M36x2	55	18	56	180	16	40	22.5	42	30	M16
250 mm	84	90	90	25	262	280	G 1	59.5	M42x2	65	21	67	200	20	50	29	46	32.8	M20
320 mm	96	110	110	28	336	350	G 1	61.5	M48x2	75	24	76	220	23.25	63	30	48	37	M24

Piston Ø	SW1	SW2	SW3	TG	VA	VD	WH	ZJ
160 mm	36	27	60	140	6	6	80	260
200 mm	36	27	60	175	6	6	95	275
250 mm	46	41	80	220	10	31	105	305.3
320 mm	55	50	95	270	10	34	120	340.5

# Accessories overview

## Overview drawing

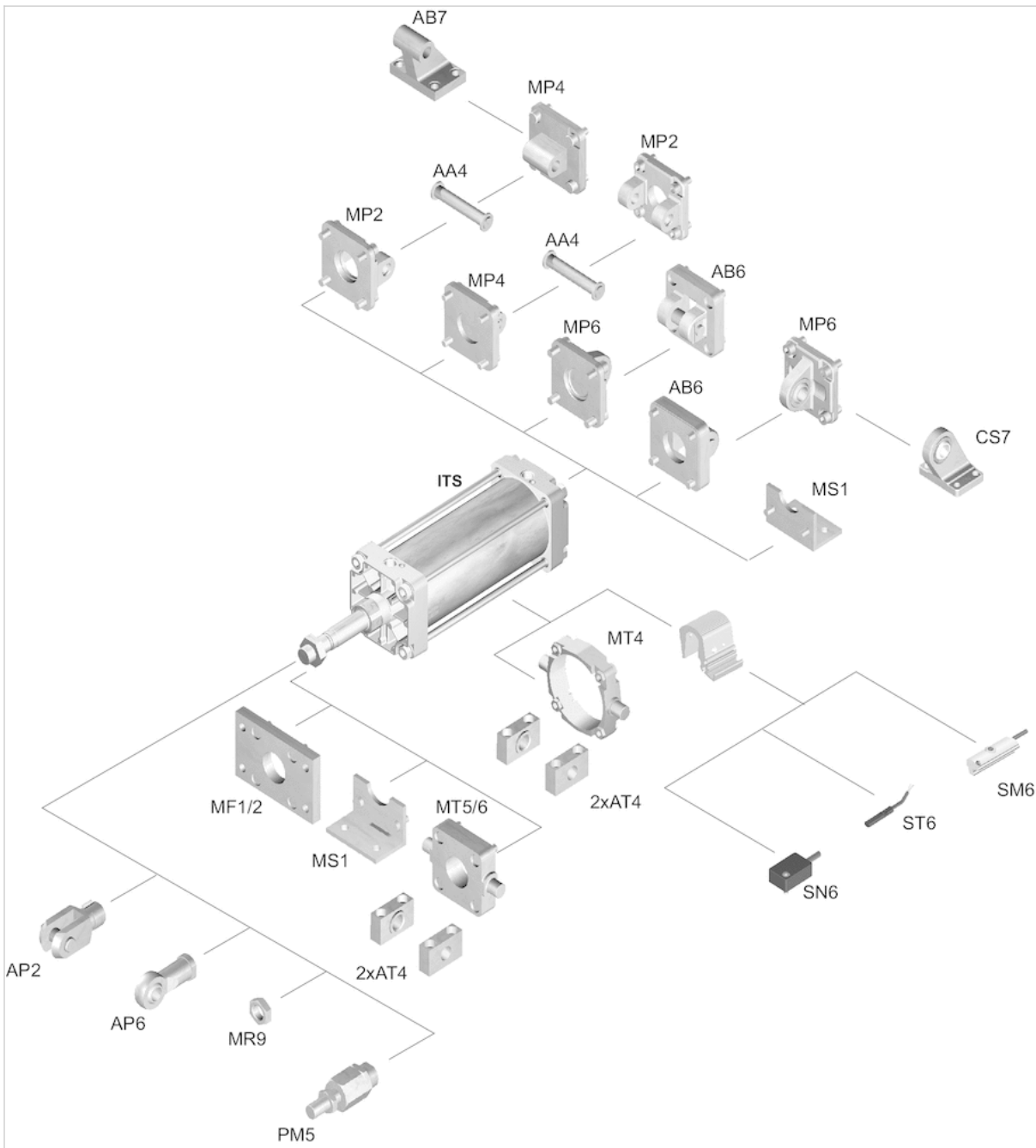

**NOTE:**

This overview drawing is only for orientation to indicate where the various accessory parts can be fastened to the cylinder. The illustration has been simplified for this purpose. It is thus not possible to derive the dimensions from this overview.

# Tie rod cylinder ISO 15552, Series ITS

- Ø 160-320 mm
- Ports G 3/4 G 1
- double-acting
- with magnetic piston
- Cushioning pneumatically adjustable
- Piston rod External thread
- Piston rod through
- ATEX optional



Standards	ISO 15552
Certificates	ATEX optional
Compressed air connection	Internal thread
Ambient temperature min./max.	-20 ... 80 °C
Medium temperature min./max.	-20 ... 80 °C
Medium	Compressed air
Max. particle size	50 µm
Oil content of compressed air	0 ... 5 mg/m <sup>3</sup>
Pressure for determining piston forces	6.3 bar

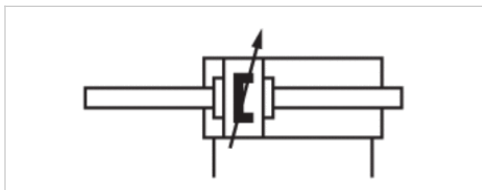

## Technical data

Piston Ø Piston rod thread Ports Piston rod Ø	160 mm M36x2 G 3/4 40 mm	200 mm M36x2 G 3/4 40 mm	250 mm M42x2 G 1 50 mm	320 mm M48x2 G 1 63 mm
Stroke 10	R480627318	R480627390	R480627486	R480632135
25	R480632697	R480627391	R480627487	R480627499
50	R480627320	R480627392	R480627488	R480627500
80	R480627321	R480627393	R480627489	R480627501
100	R480627322	R480627394	R480627490	R480627502
125	R480627323	R480627395	R480627491	R480627503
160	R480635054	R480627396	R480627492	R480627504
200	R480627325	R480627397	R480627493	R480631095
250	R480627326	R480627398	R480627494	R480627506
320	R480627327	R480627399	R480627495	R480627507
400	R480627328	R480627400	R480627496	R480627508
500	R480627329	R480627401	R480627497	R480627509

## Technical data

Piston Ø	160 mm	200 mm	250 mm	320 mm
Retracting piston force	11875 N	19000 N	29688 N	48704 N
Extracting piston force	11875 N	19000 N	29688 N	48704 N
Cushioning length	46 mm	46 mm	56 mm	56 mm
Cushioning energy	160 J	170 J	180 J	190 J
Weight 0 mm stroke	14.44 kg	17.93 kg	28.46 kg	51.23 kg
Weight +10 mm stroke	0.42 kg	0.42 kg	0.76 kg	1.22 kg
Working pressure min./max.	1.5 ... 10 bar	1.5 ... 10 bar	1.5 ... 10 bar	2 ... 10 bar
Stroke max.	1000 mm	1000 mm	1000 mm	1000 mm

## Technical information

The pressure dew point must be at least 15 °C under ambient and medium temperature and may not exceed 3 °C .

The oil content of compressed air must remain constant during the life cycle.

Use only the approved oils from AVENTICS. Further information can be found in the "Technical information" document (available in the MediaCentre).

Clamping piece for magnetic field sensor necessary

ATEX-certified cylinders with identification II 2G Ex h IIB T4 Gb / II 2D Ex h IIIB T135°C Db\_X can be generated in the Internet configurator.

## Technical information

Material	
Cylinder tube	Aluminum, anodized
Piston rod	Stainless steel
Front cover	Die-cast aluminum
End cover	Die-cast aluminum
Seal	Acrylonitrile butadiene rubber
Nut for piston rod	Steel, galvanized
Scraper	Acrylonitrile butadiene rubber
Tie-rods	Stainless steel

## Dimensions

### Dimensions

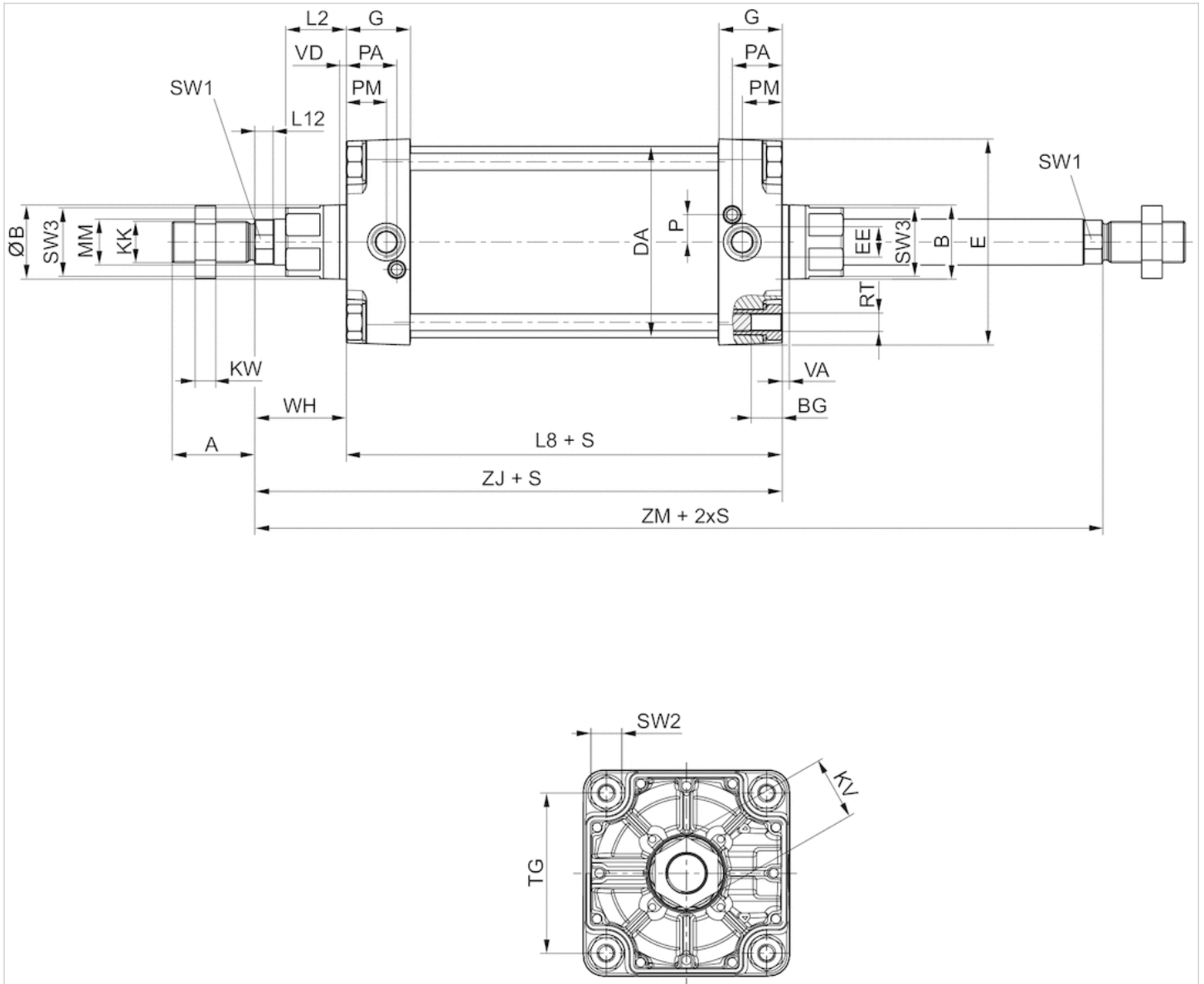

S = stroke

## Dimensions

Piston $\varnothing$	A	B	$\varnothing B$	BG	DA	E	EE	G	KK	KV	KW	L2	L8	L12	MM	P	PA	PM	RT
160 mm	72	65	65	24	167	180	G 3/4	56	M36x2	55	18	53	180	16	40	24	45	35	M16
200 mm	72	75	75	24	210	220	G 3/4	54	M36x2	55	18	56	180	16	40	22.5	42	30	M16
250 mm	84	90	90	25	262	280	G 1	59.5	M42x2	65	21	67	200	20	50	29	46	32.8	M20
320 mm	96	110	110	28	336	350	G 1	61.5	M48x2	75	24	76	220	23.25	63	30	48	37	M24

Piston $\varnothing$	SW1	SW2	SW3	TG	VD	WH	ZJ	ZM
160 mm	36	27	60	140	6	80	260	340
200 mm	36	27	60	175	6	95	275	370
250 mm	46	41	80	220	31	105	305.3	411
320 mm	55	50	95	270	34	120	340.5	462

# Diagrams

## Cushioning diagram

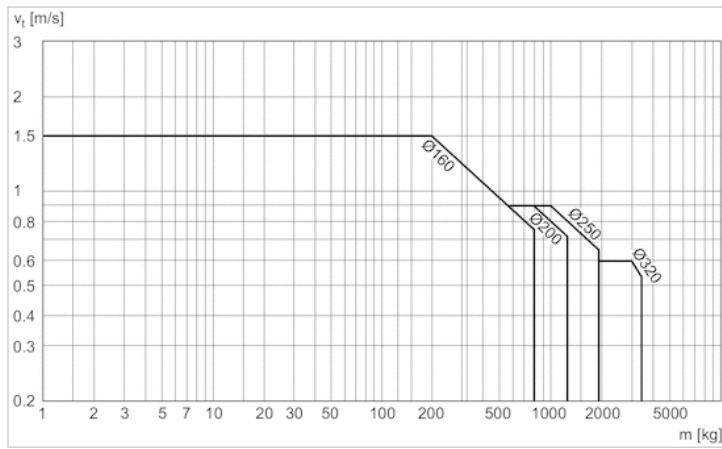

v = Piston velocity [m/s]

m = Cushionable mass [kg]

# Accessories overview

## Overview drawing

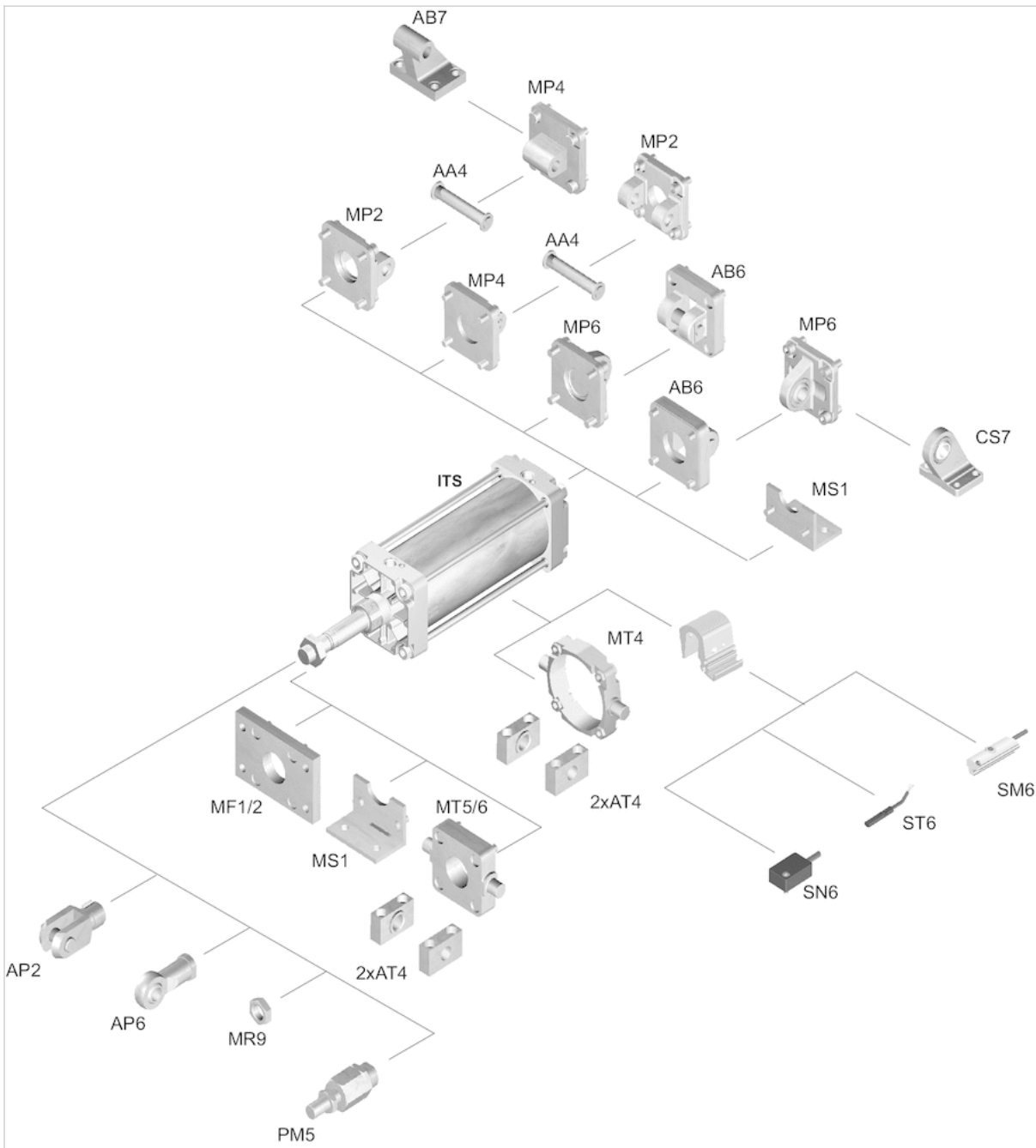

**NOTE:**

This overview drawing is only for orientation to indicate where the various accessory parts can be fastened to the cylinder. The illustration has been simplified for this purpose. It is thus not possible to derive the dimensions from this overview.



# Tie rod cylinder ISO 15552, Series ITS

- Ø 160-320 mm
- Ports G 3/4 G 1
- double-acting
- Cushioning pneumatically adjustable
- Piston rod External thread
- Piston rod through
- ATEX optional



Standards	ISO 15552
Certificates	ATEX optional
Compressed air connection	Internal thread
Working pressure min./max.	2 ... 10 bar
Ambient temperature min./max.	-20 ... 80 °C
Medium temperature min./max.	-20 ... 80 °C
Medium	Compressed air
Max. particle size	50 µm
Oil content of compressed air	0 ... 5 mg/m <sup>3</sup>
Pressure for determining piston forces	6.3 bar

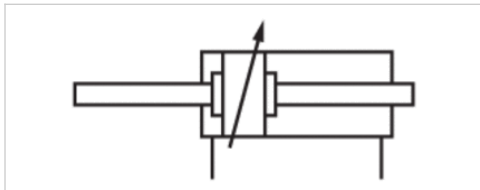

## Technical data

Piston Ø Piston rod thread Ports Piston rod Ø	160 mm M36x2 G 3/4 40 mm	200 mm M36x2 G 3/4 40 mm	250 mm M42x2 G 1 50 mm	320 mm M48x2 G 1 63 mm
Stroke 25	R480627715	R480627727	R480627739	R480627751
50	R480627716	R480627728	R480627740	R480627752
80	R480635557	R480635566	R480627741	R480627753
100	R480627718	R480627730	R480627742	R480627754
125	R480635556	R480627731	R480627743	R480627755
160	R480627720	R480627732	R480627744	R480627756
200	R480627721	R480627733	R480627745	R480627757
250	R480627722	R480627734	R480627746	R480627758
320	R480627723	R480635572	R480627747	R480627759
400	R480627724	R480627736	R480627748	R480627760
500	R480627725	R480627737	R480627749	R480627761

## Technical data

Piston Ø	160 mm	200 mm	250 mm	320 mm
Retracting piston force	11875 N	19000 N	29688 N	48704 N
Extracting piston force	11875 N	19000 N	29688 N	48704 N
Cushioning length	46 mm	46 mm	56 mm	56 mm
Cushioning energy	160 J	170 J	180 J	190 J
Weight 0 mm stroke	14.44 kg	17.93 kg	28.46 kg	51.23 kg
Weight +10 mm stroke	0.42 kg	0.42 kg	0.76 kg	1.22 kg
Stroke max.	1000 mm	1000 mm	1000 mm	1000 mm

## Technical information

The pressure dew point must be at least 15 °C under ambient and medium temperature and may not exceed 3 °C .

The oil content of compressed air must remain constant during the life cycle.

Use only the approved oils from AVENTICS. Further information can be found in the "Technical information" document (available in the MediaCentre).

ATEX-certified cylinders with identification II 2G Ex h IIB T4 Gb / II 2D Ex h IIIB T135°C Db\_X can be generated in the Internet configurator.

## Technical information

Material	
Cylinder tube	Aluminum, anodized
Piston rod	Stainless steel
Front cover	Die-cast aluminum
End cover	Die-cast aluminum
Seal	Acrylonitrile butadiene rubber
Nut for piston rod	Steel, galvanized
Scraper	Acrylonitrile butadiene rubber
Tie-rods	Stainless steel

## Dimensions

### Dimensions

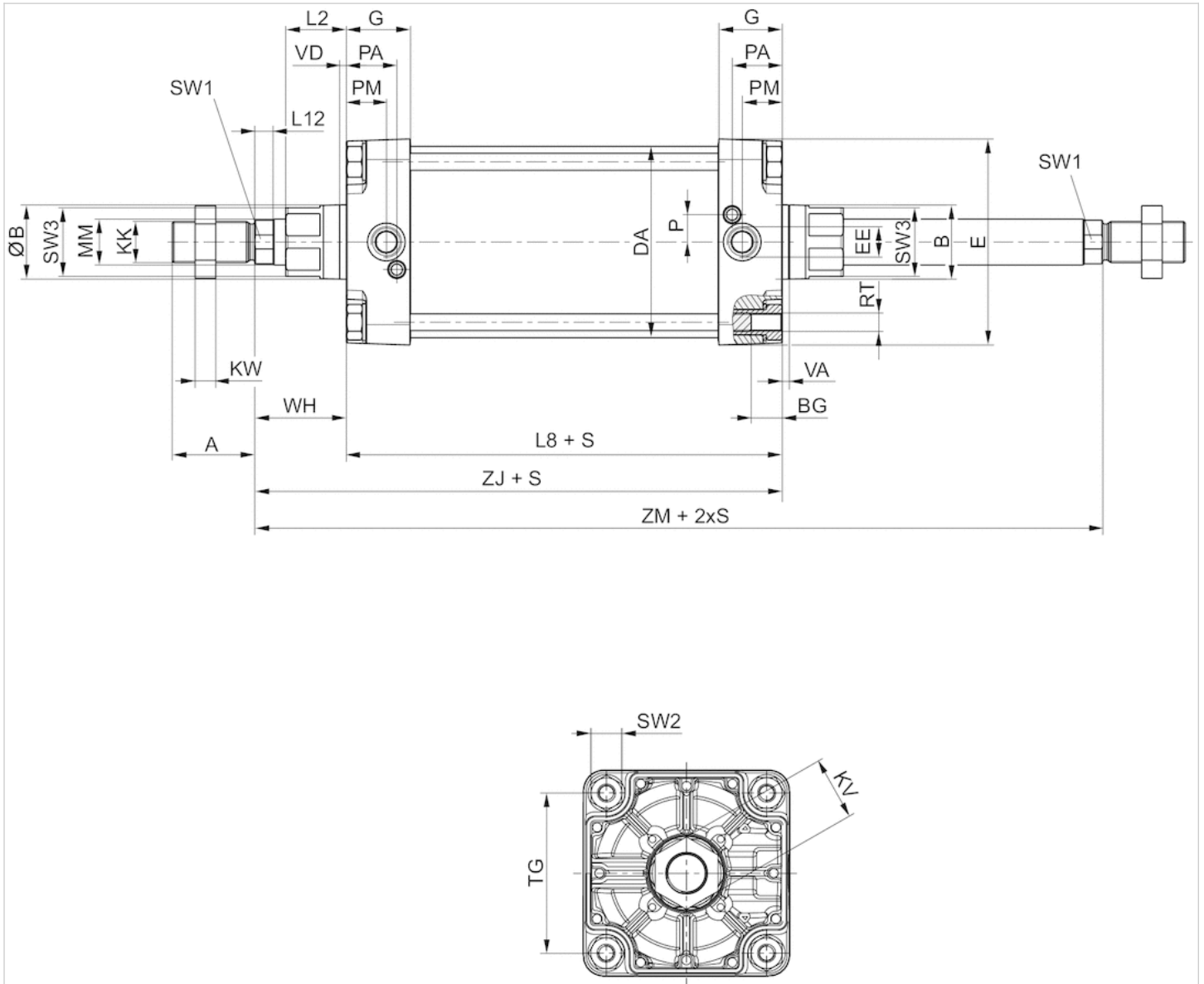

S = stroke

## Dimensions

Piston $\varnothing$	A	B	$\varnothing B$	BG	DA	E	EE	G	KK	KV	KW	L2	L8	L12	MM	P	PA	PM	RT
160 mm	72	65	65	24	167	180	G 3/4	56	M36x2	55	18	53	180	16	40	24	45	35	M16
200 mm	72	75	75	24	210	220	G 3/4	54	M36x2	55	18	56	180	16	40	22.5	42	30	M16
250 mm	84	90	90	25	262	280	G 1	59.5	M42x2	65	21	67	200	20	50	29	46	32.8	M20
320 mm	96	110	110	28	336	350	G 1	61.5	M48x2	75	24	76	220	23.25	63	30	48	37	M24

Piston $\varnothing$	SW1	SW2	SW3	TG	VD	WH	ZJ	ZM
160 mm	36	27	60	140	6	80	260	340
200 mm	36	27	60	175	6	95	275	370
250 mm	46	41	80	220	31	105	305.3	411
320 mm	55	50	95	270	34	120	340.5	462

## Diagrams

### Cushioning diagram

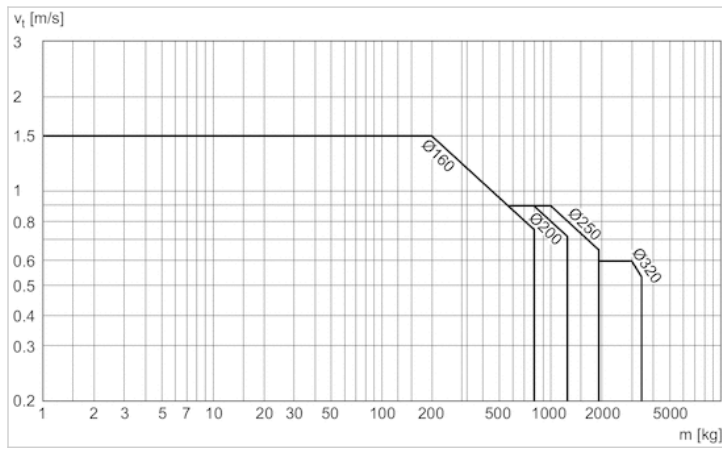

$v$  = Piston velocity [m/s]

$m$  = Cushionable mass [kg]

# Accessories overview

## Overview drawing

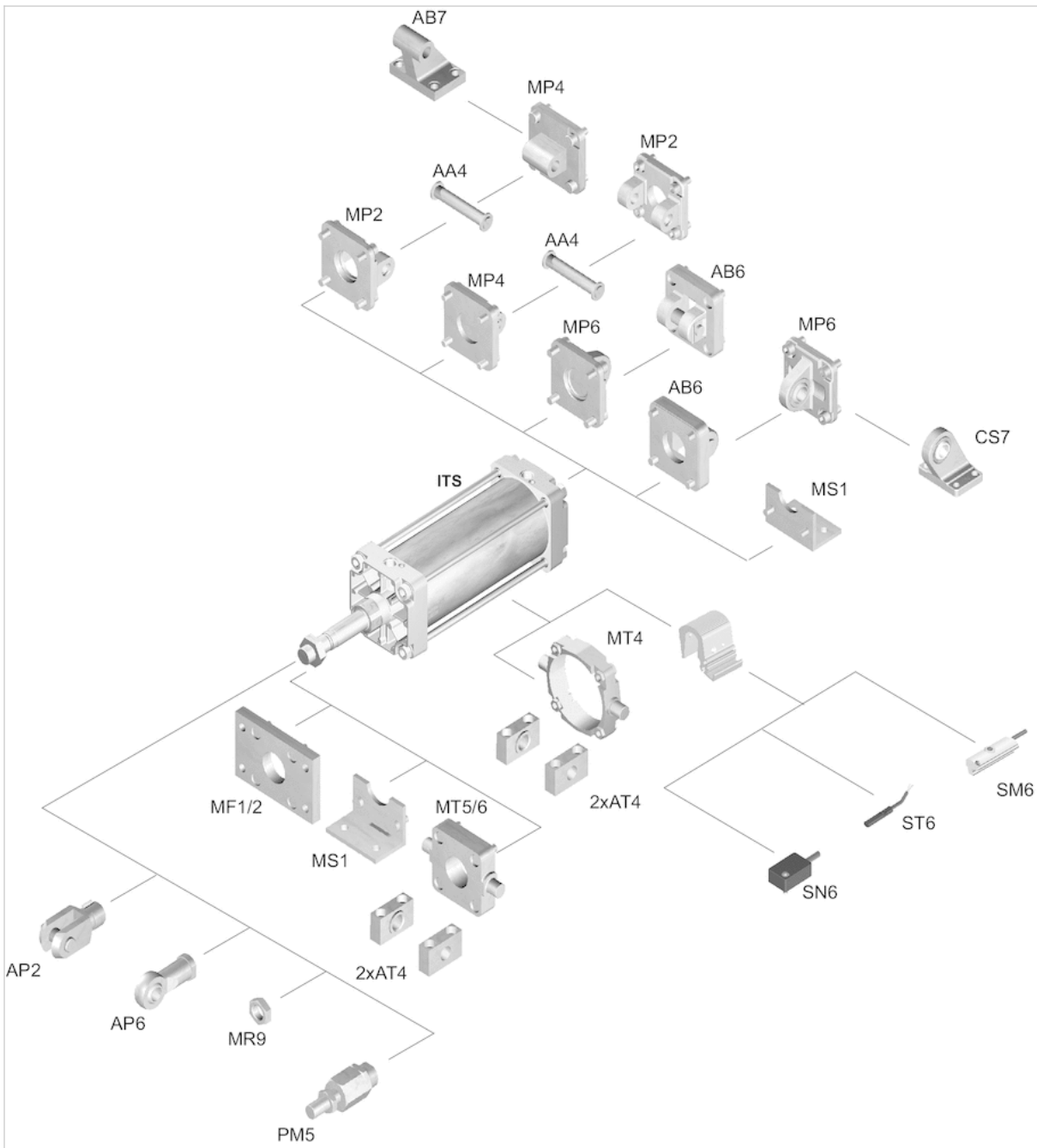

**NOTE:**

This overview drawing is only for orientation to indicate where the various accessory parts can be fastened to the cylinder. The illustration has been simplified for this purpose. It is thus not possible to derive the dimensions from this overview.

# Tie rod cylinder ISO 15552, Series ITS

- Ø 160-320 mm
- Ports G 3/4 G 1
- double-acting
- with magnetic piston
- Cushioning pneumatically adjustable
- with trunnion mounting
- Piston rod External thread
- ATEX optional



Standards	ISO 15552
Certificates	ATEX optional
Compressed air connection	Internal thread
Working pressure min./max.	2 ... 10 bar
Ambient temperature min./max.	-20 ... 80 °C
Medium temperature min./max.	-20 ... 80 °C
Medium	Compressed air
Max. particle size	50 µm
Oil content of compressed air	0 ... 5 mg/m <sup>3</sup>
Pressure for determining piston forces	6.3 bar

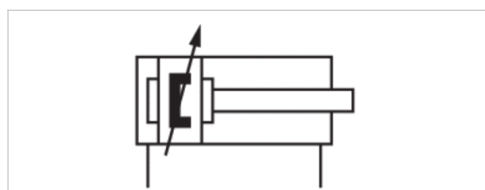

## Technical data

Piston Ø Piston rod thread Ports Piston rod Ø	160 mm M36x2 G 3/4 40 mm	200 mm M36x2 G 3/4 40 mm	250 mm M42x2 G 1 50 mm	320 mm M48x2 G 1 63 mm
Stroke 25	R480627343	R480627415	R480627535	R480627547
50	R480627344	R480627416	R480627536	R480627548
80	R480627345	R480627417	R480627537	R480627549
100	R480627346	R480627418	R480627538	R480627550
125	R480627347	R480627419	R480627539	R480627551
160	R480627348	R480627420	R480627540	R480627552
200	R480627349	R480627421	R480627541	R480627553
250	R480627350	R480627422	R480627542	R480627554
320	R480627351	R480627423	R480627543	R480627555
400	R480627352	R480627424	R480627544	R480627556
500	R480627353	R480627425	R480627545	R480627557

## Technical data

Piston Ø	160 mm	200 mm	250 mm	320 mm
Retracting piston force	11875 N	19000 N	29688 N	48704 N
Extracting piston force	12667 N	19792 N	30925 N	50668 N
Cushioning length	46 mm	46 mm	56 mm	56 mm
Cushioning energy	160 J	170 J	180 J	190 J
Weight 0 mm stroke	15.67 kg	20.25 kg	34.98 kg	82.49 kg
Weight +10 mm stroke	0.21 kg	0.21 kg	0.38 kg	0.61 kg
Stroke max.	2700 mm	2700 mm	2500 mm	2500 mm

## Technical information

The pressure dew point must be at least 15 °C under ambient and medium temperature and may not exceed 3 °C .

The oil content of compressed air must remain constant during the life cycle.

Use only the approved oils from AVENTICS. Further information can be found in the "Technical information" document (available in the MediaCentre).

Clamping piece for magnetic field sensor necessary

The trunnion mounting is positioned in the center at the factory and can be adjusted later.

ATEX-certified cylinders with identification II 2G Ex h IIB T4 Gb / II 2D Ex h IIIB T135°C Db\_X can be generated in the Internet configurator.

## Technical information

Material	
Cylinder tube	Aluminum, anodized
Piston rod	Stainless steel
Front cover	Die-cast aluminum
End cover	Die-cast aluminum
Seal	Acrylonitrile butadiene rubber
Nut for piston rod	Steel, galvanized
Scraper	Acrylonitrile butadiene rubber
Trunnion mounting	Nodular graphite iron
Tie-rods	Stainless steel

# Dimensions

## Dimensions

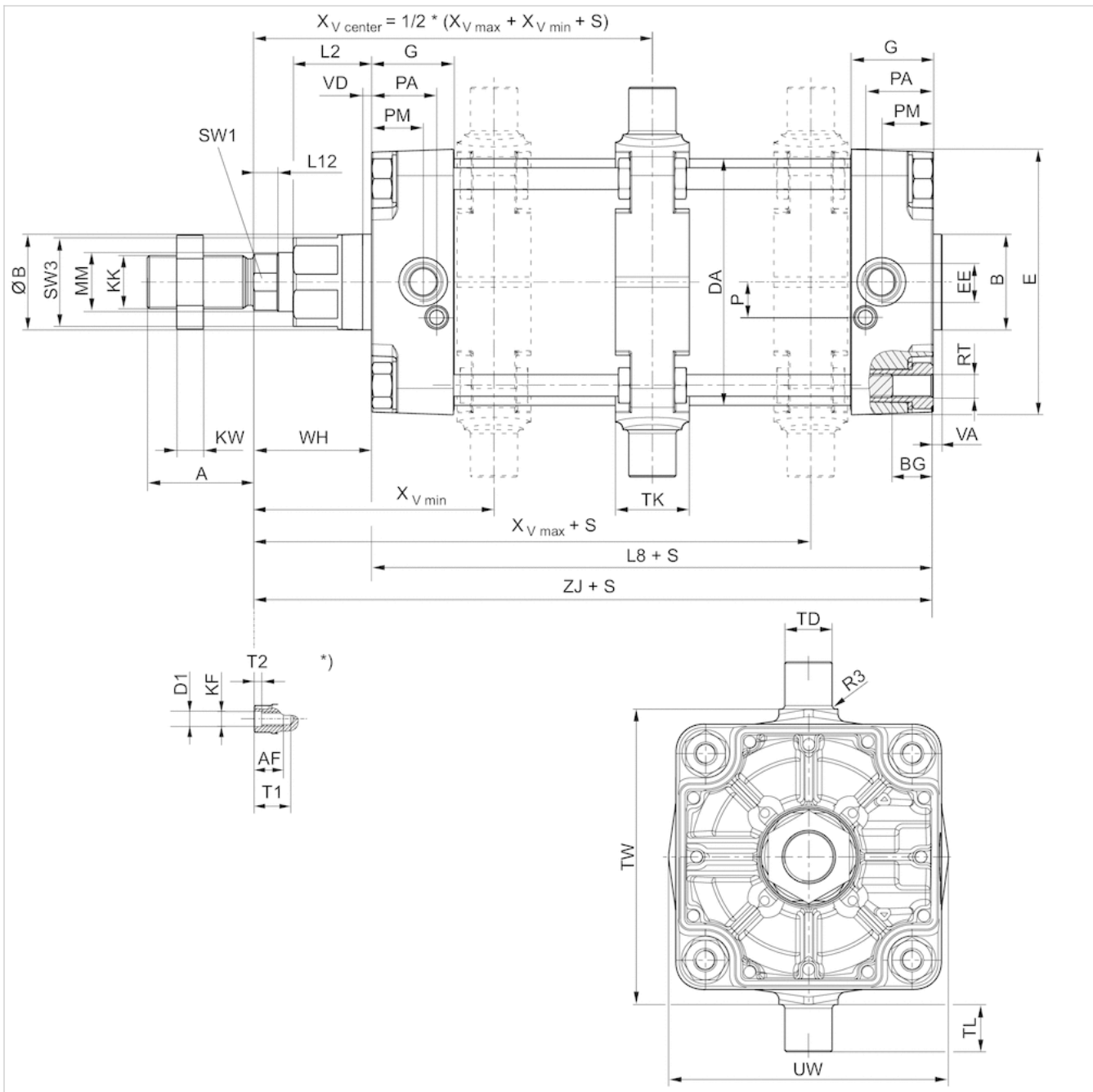

S = stroke

\*) For cylinders with optional piston rod with internal thread



## Dimensions

Piston Ø	A	B	ØB	BG	DA	E	EE	G	KK	KV	KW	L2	L8	L12	MM	P	PA	PM	R3
160 mm	72	65	65	24	167	180	G 3/4	56	M36x2	55	18	53	180	16	40	24	45	35	2.5
200 mm	72	75	75	24	210	220	G 3/4	54	M36x2	55	18	56	180	16	40	22.5	42	30	2.5
250 mm	84	90	90	25	262	280	G 1	59.5	M42x2	65	21	67	200	20	50	29	46	32.8	3
320 mm	96	110	110	28	336	350	G 1	61.5	M48x2	75	24	76	220	23.25	63	30	48	37	3.2

Piston Ø	RT	SW1	SW2	SW3	TD e9	TG	TK	TL h14	TW h14	UW	VD	WH	XV min	XV max
160 mm	M16	36	27	60	32	140	50	32	200	190	6	80	163	177
200 mm	M16	36	27	60	32	175	50	32	250	240	6	95	177	193
250 mm	M20	46	41	80	40	220	60	40	320	310	31	105	195	215
320 mm	M24	55	50	95	50	270	70	50	400	400	34	120	228	233

Piston Ø	ZJ
160 mm	260
200 mm	275
250 mm	305.3
320 mm	340.5

## Diagrams

### Cushioning diagram

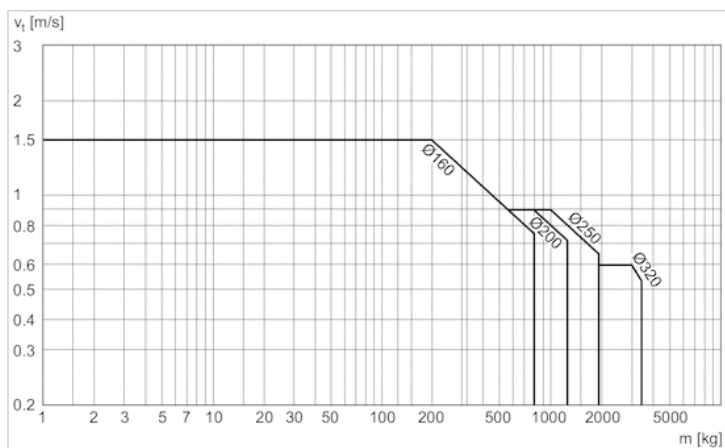

v = Piston velocity [m/s]

m = Cushionable mass [kg]

# Accessories overview

## Overview drawing

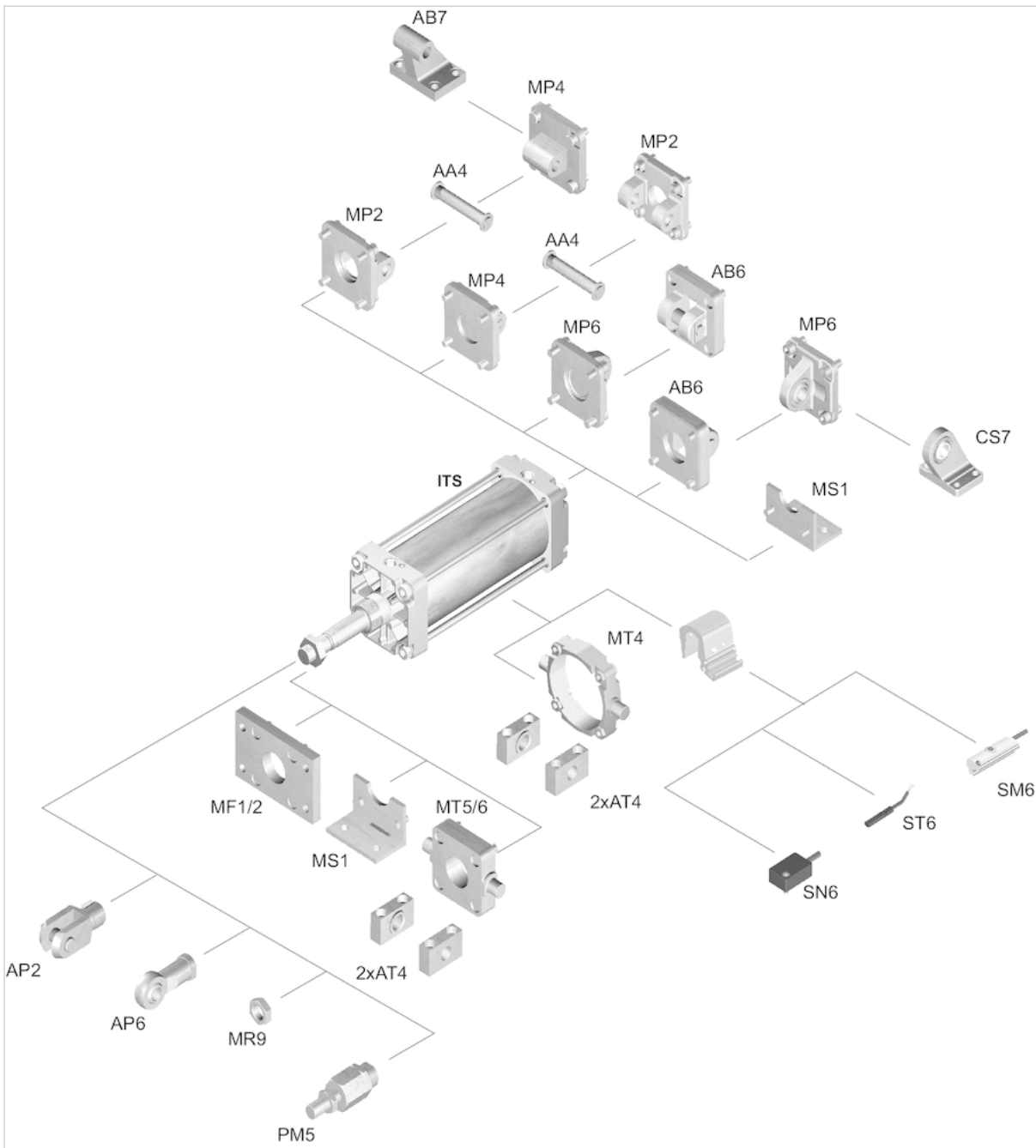

**NOTE:**

This overview drawing is only for orientation to indicate where the various accessory parts can be fastened to the cylinder. The illustration has been simplified for this purpose. It is thus not possible to derive the dimensions from this overview.

# Tie rod cylinder ISO 15552, Series ITS

- Ø 160-320 mm
- Ports G 3/4 G 1
- double-acting
- Cushioning pneumatically adjustable
- with trunnion mounting
- Piston rod External thread
- ATEX optional



Standards	ISO 15552
Certificates	ATEX optional
Compressed air connection	Internal thread
Working pressure min./max.	2 ... 10 bar
Ambient temperature min./max.	-20 ... 80 °C
Medium temperature min./max.	-20 ... 80 °C
Medium	Compressed air
Max. particle size	50 µm
Oil content of compressed air	0 ... 5 mg/m <sup>3</sup>
Pressure for determining piston forces	6.3 bar

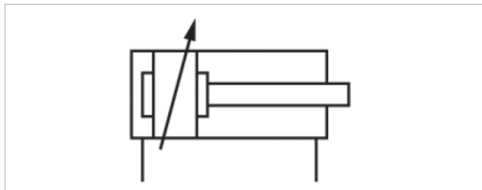

## Technical data

Piston Ø Piston rod thread Ports Piston rod Ø	160 mm M36x2 G 3/4 40 mm	200 mm M36x2 G 3/4 40 mm	250 mm M42x2 G 1 50 mm	320 mm M48x2 G 1 63 mm
Stroke 25	R480627331	R480633348	R480627511	R480627523
50	R480627332	R480633346	R480627512	R480627524
80	R480627333	R480627405	R480627513	R480627525
100	R480627334	R480631340	R480627514	R480627526
125	R480627335	R480631542	R480627515	R480627527
160	R480627336	R480627408	R480627516	R480627528
200	R480627337	R480627409	R480627517	R480627529
250	R480627338	R480627410	R480627518	R480627530
320	R480627339	R480627411	R480627519	R480627531
400	R480627340	R480627412	R480627520	R480627532
500	R480627341	R480627413	R480627521	R480627533

## Technical data

Piston Ø	160 mm	200 mm	250 mm	320 mm
Retracting piston force	11875 N	19000 N	19000 N	48704 N
Extracting piston force	12667 N	19792 N	19792 N	50668 N
Cushioning length	46 mm	46 mm	56 mm	56 mm
Cushioning energy	160 J	170 J	180 J	190 J
Weight 0 mm stroke	15.67 kg	20.25 kg	34.98 kg	82.49 kg
Weight +10 mm stroke	0.21 kg	0.21 kg	0.38 kg	0.61 kg
Stroke max.	2700 mm	2700 mm	2500 mm	2500 mm

## Technical information

The pressure dew point must be at least 15 °C under ambient and medium temperature and may not exceed 3 °C .

The oil content of compressed air must remain constant during the life cycle.

Use only the approved oils from AVENTICS. Further information can be found in the "Technical information" document (available in the MediaCentre).

The trunnion mounting is positioned in the center at the factory and can be adjusted later.

ATEX-certified cylinders with identification II 2G Ex h IIB T4 Gb / II 2D Ex h IIIB T135°C Db\_X can be generated in the Internet configurator.

## Technical information

Material	
Cylinder tube	Aluminum, anodized
Piston rod	Stainless steel
Front cover	Die-cast aluminum
End cover	Die-cast aluminum
Seal	Acrylonitrile butadiene rubber
Nut for piston rod	Steel, galvanized
Scraper	Acrylonitrile butadiene rubber
Trunnion mounting	Nodular graphite iron
Tie-rods	Stainless steel

# Dimensions

## Dimensions

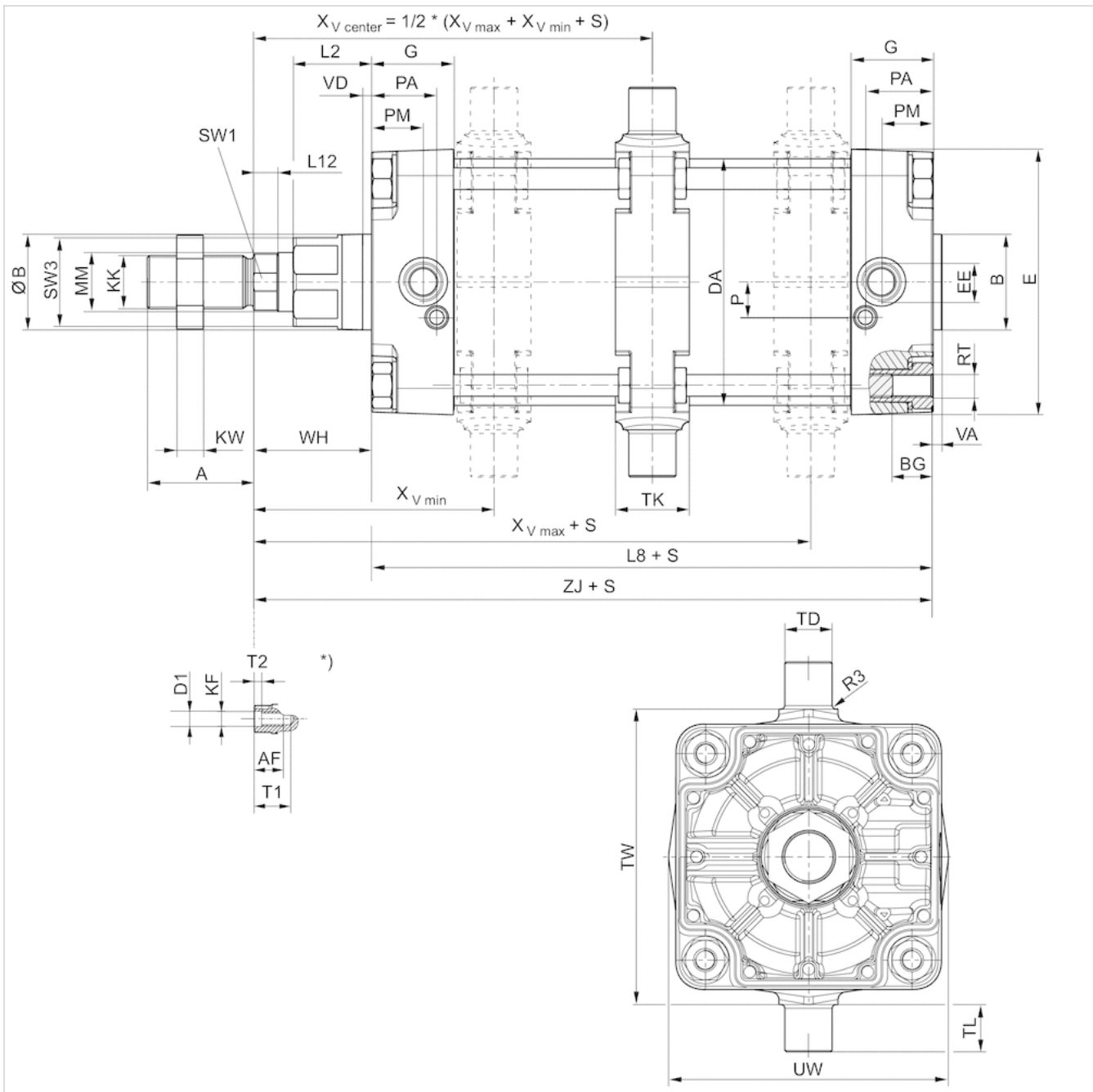

S = stroke

\*) For cylinders with optional piston rod with internal thread

## Dimensions

Piston Ø	A	B	ØB	BG	DA	E	EE	G	KK	KV	KW	L2	L8	L12	MM	P	PA	PM	R3
160 mm	72	65	65	24	167	180	G 3/4	56	M36x2	55	18	53	180	16	40	24	45	35	2.5
200 mm	72	75	75	24	210	220	G 3/4	54	M36x2	55	18	56	180	16	40	22.5	42	30	2.5
250 mm	84	90	90	25	262	280	G 1	59.5	M42x2	65	21	67	200	20	50	29	46	32.8	3
320 mm	96	110	110	28	336	350	G 1	61.5	M48x2	75	24	76	220	23.25	63	30	48	37	3.2

Piston Ø	RT	SW1	SW2	SW3	TD e9	TG	TK	TL h14	TW h14	UW	VD	WH	XV min	XV max
160 mm	M16	36	27	60	32	140	50	32	200	190	6	80	163	177
200 mm	M16	36	27	60	32	175	50	32	250	240	6	95	177	193
250 mm	M20	46	41	80	40	220	60	40	320	310	31	105	195	215
320 mm	M24	55	50	95	50	270	70	50	400	400	34	120	228	233

Piston Ø	ZJ
160 mm	260
200 mm	275
250 mm	305.3
320 mm	340.5

## Diagrams

### Cushioning diagram

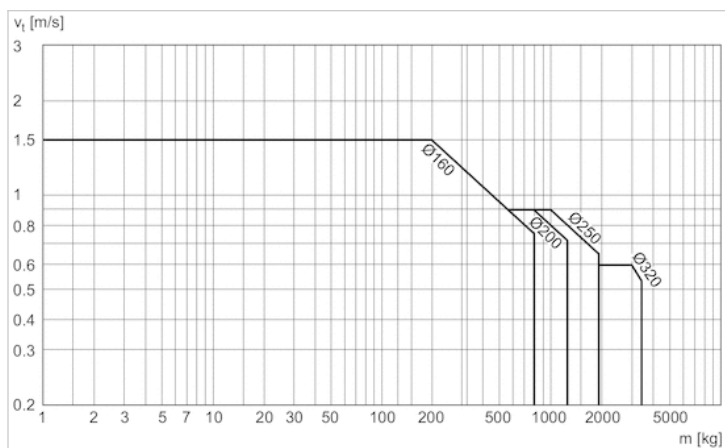

v = Piston velocity [m/s]

m = Cushionable mass [kg]

# Accessories overview

## Overview drawing

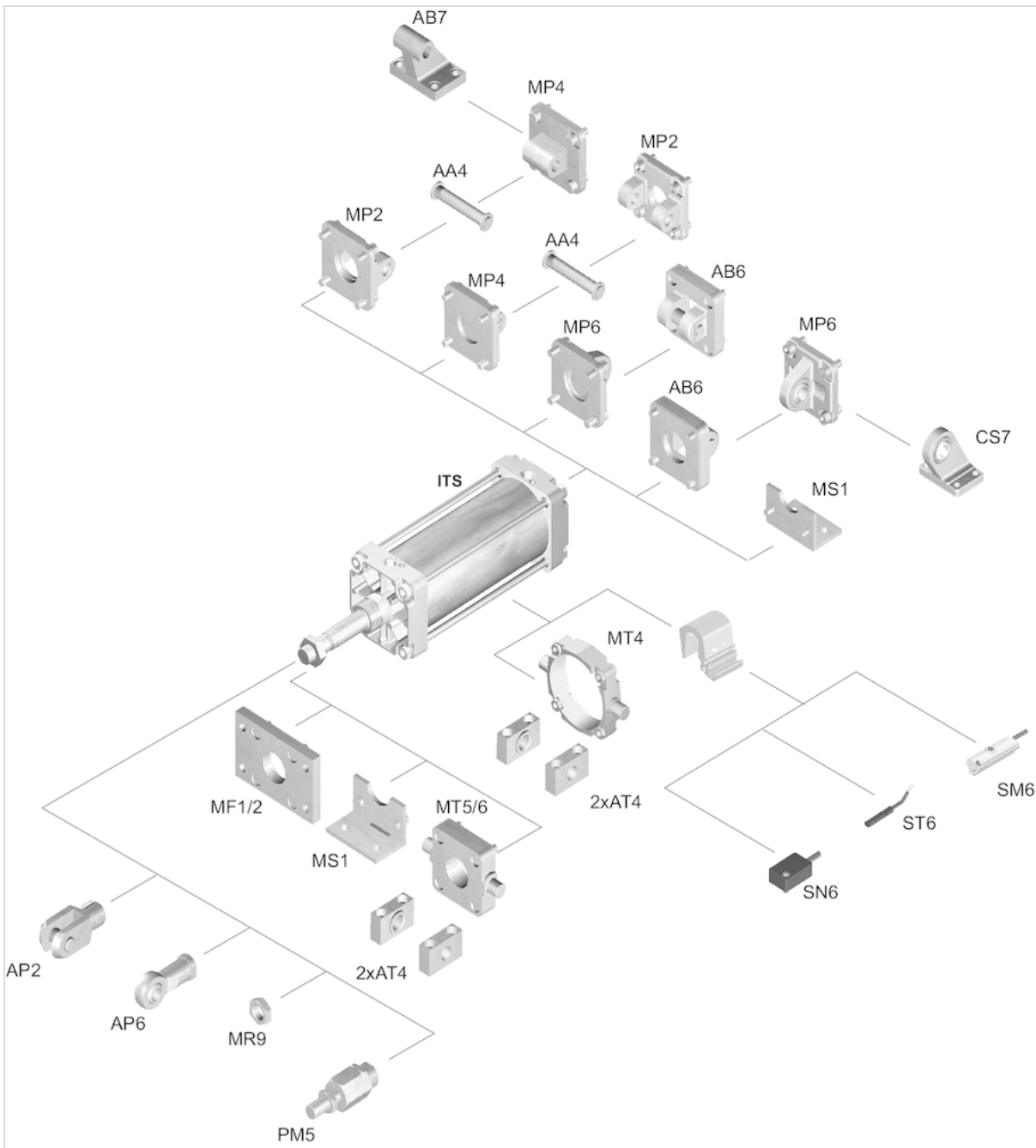

**NOTE:**

This overview drawing is only for orientation to indicate where the various accessory parts can be fastened to the cylinder. The illustration has been simplified for this purpose. It is thus not possible to derive the dimensions from this overview.

# Tie rod cylinder ISO 15552, Series ITS

- Ø 160-320 mm
- Ports G 3/4 G 1
- double-acting
- with magnetic piston
- Cushioning pneumatically adjustable
- Piston rod External thread
- Heat resistant

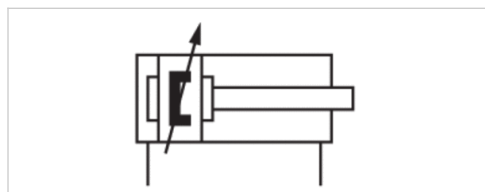

Standards	ISO 15552
Compressed air connection	Internal thread
Working pressure min./max.	2 ... 10 bar
Ambient temperature min./max.	-10 ... 120 °C
Medium temperature min./max.	-10 ... 120 °C
Medium	Compressed air
Max. particle size	50 µm
Oil content of compressed air	0 ... 5 mg/m <sup>3</sup>
Pressure for determining piston forces	6.3 bar

## Technical data

Piston Ø Piston rod thread Ports Piston rod Ø	160 mm M36x2 G 3/4 40 mm	200 mm M36x2 G 3/4 40 mm	250 mm M42x2 G 1 50 mm	320 mm M48x2 G 1 63 mm
Stroke 25	R480627619	R480627631	R480627643	R480627655
50	R480627620	R480627632	R480627644	R480627656
80	R480627621	R480627633	R480627645	R480627657
100	R480627622	R480627634	R480627646	R480627658
125	R480627623	R480627635	R480627647	R480627659
160	R480627624	R480627636	R480627648	R480627660
200	R480627625	R480627637	R480627649	R480627661
250	R480627626	R480627638	R480627650	R480627662
320	R480627627	R480627639	R480627651	R480627663
400	R480627628	R480627640	R480627652	R480627664
500	R480627629	R480627641	R480627653	R480627665



## Technical data

Piston Ø	160 mm	200 mm	250 mm	320 mm
Retracting piston force	11875 N	19000 N	29688 N	48704 N
Extracting piston force	12667 N	19792 N	30925 N	50668 N
Cushioning length	46 mm	46 mm	56 mm	56 mm
Cushioning energy	160 J	170 J	180 J	190 J
Weight 0 mm stroke	12.5 kg	15.67 kg	25.87 kg	46.89 kg
Weight +10 mm stroke	0.21 kg	0.21 kg	0.38 kg	0.61 kg
Stroke max.	2700 mm	2700 mm	2500 mm	2500 mm

## Technical information

The pressure dew point must be at least 15 °C under ambient and medium temperature and may not exceed 3 °C .

The oil content of compressed air must remain constant during the life cycle.

Use only the approved oils from AVENTICS. Further information can be found in the "Technical information" document (available in the MediaCentre).

## Technical information

Material	
Cylinder tube	Aluminum, anodized
Piston rod	Stainless steel
Front cover	Die-cast aluminum
End cover	Die-cast aluminum
Seal	Fluorocaoutchouc
Nut for piston rod	Steel, galvanized
Scraper	Fluorocaoutchouc
Tie-rods	Stainless steel

## Dimensions

### Dimensions

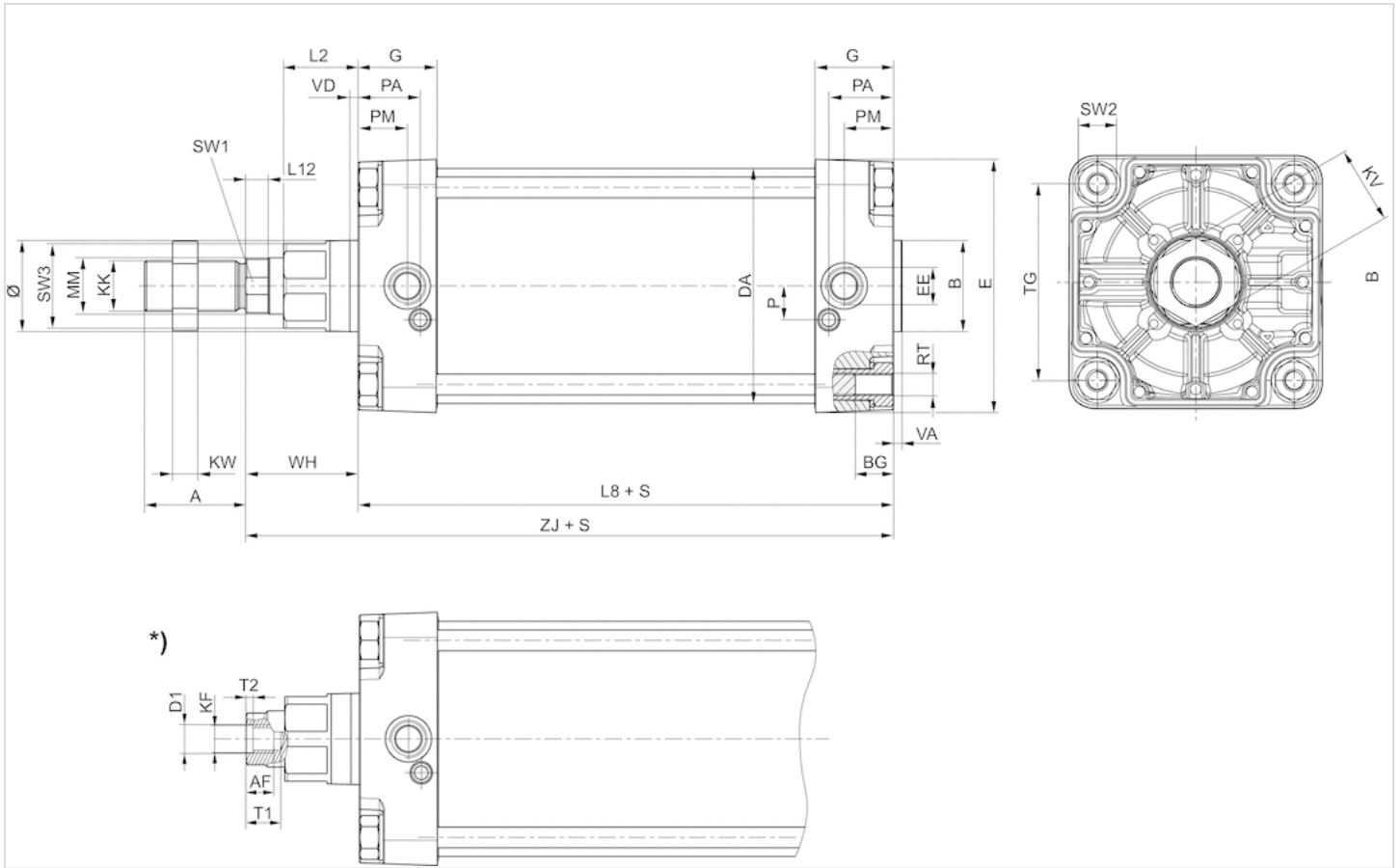

S = stroke

\*) For cylinders with optional piston rod with internal thread

## Dimensions

Piston Ø	A	B	ØB	BG	DA	E	EE	G	KK	KV	KW	L2	L8	L12	MM	P	PA	PM	RT
160 mm	72	65	65	24	167	180	G 3/4	56	M36x2	55	18	53	180	16	40	24	45	35	M16
200 mm	72	75	75	24	210	220	G 3/4	54	M36x2	55	18	56	180	16	40	22.5	42	30	M16
250 mm	84	90	90	25	262	280	G 1	59.5	M42x2	65	21	67	200	20	50	29	46	32.8	M20
320 mm	96	110	110	28	336	350	G 1	61.5	M48x2	75	24	76	220	23.25	63	30	48	37	M24

Piston Ø	SW1	SW2	SW3	TG	VA	VD	WH	ZJ
160 mm	36	27	60	140	6	6	80	260
200 mm	36	27	60	175	6	6	95	275
250 mm	46	41	80	220	10	31	105	305.3
320 mm	55	50	95	270	10	34	120	340.5

## Diagrams

### Cushioning diagram

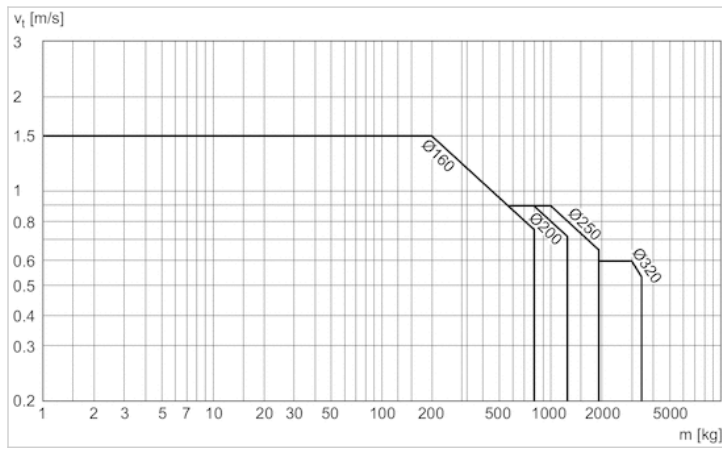

v = Piston velocity [m/s]

m = Cushionable mass [kg]

# Accessories overview

## Overview drawing

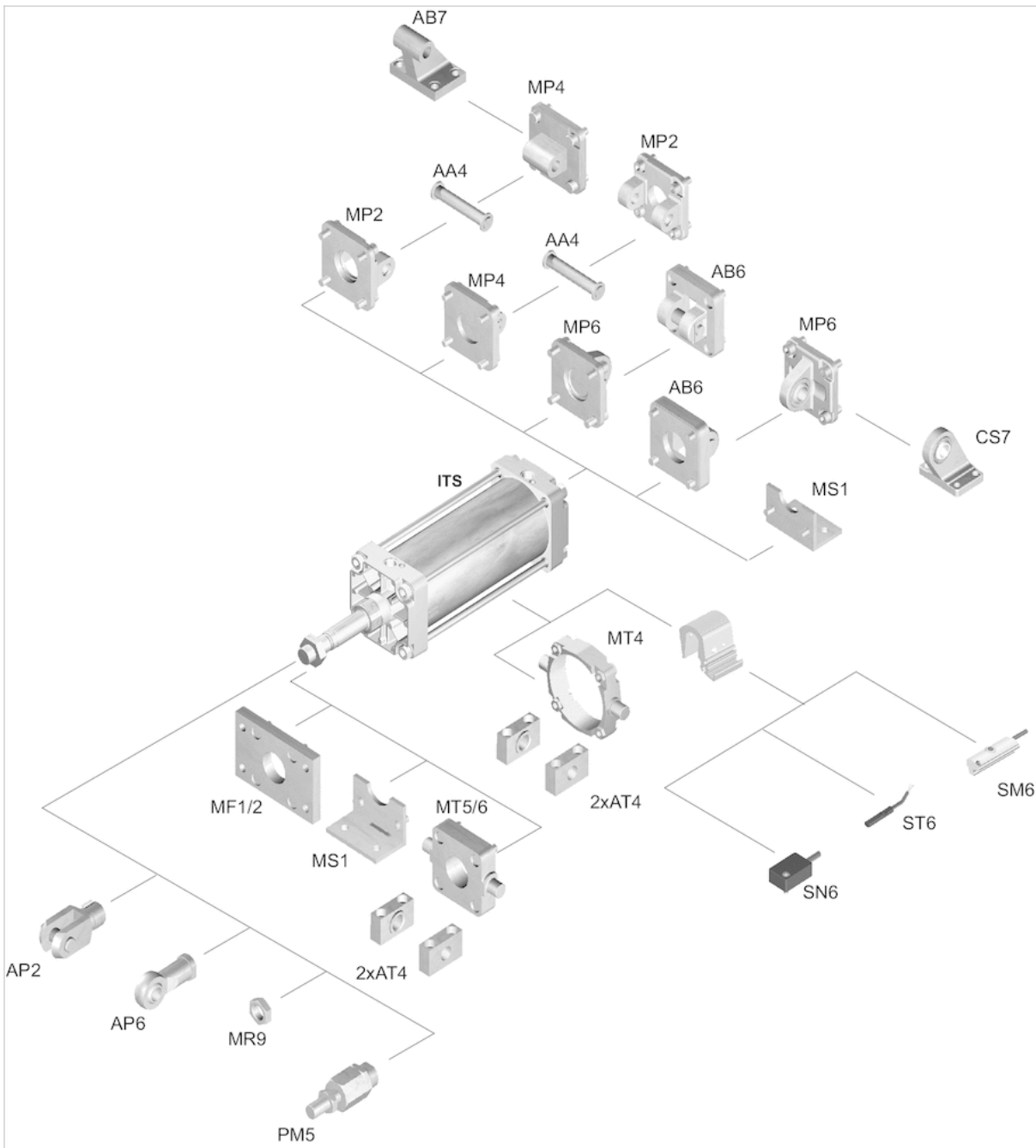

**NOTE:**

This overview drawing is only for orientation to indicate where the various accessory parts can be fastened to the cylinder. The illustration has been simplified for this purpose. It is thus not possible to derive the dimensions from this overview.

# Tie rod cylinder ISO 15552, Series ITS

- Ø 160-320 mm
- Ports G 3/4 G 1
- double-acting
- Cushioning pneumatically adjustable
- Piston rod External thread
- Heat resistant



Standards	ISO 15552
Compressed air connection	Internal thread
Working pressure min./max.	2 ... 10 bar
Ambient temperature min./max.	-10 ... 150 °C
Medium temperature min./max.	-10 ... 150 °C
Medium	Compressed air
Max. particle size	50 µm
Oil content of compressed air	0 ... 5 mg/m <sup>3</sup>
Pressure for determining piston forces	6.3 bar

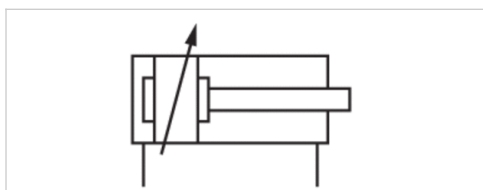

## Technical data

Piston Ø Piston rod thread Ports Piston rod Ø	160 mm M36x2 G 3/4 40 mm	200 mm M36x2 G 3/4 40 mm	250 mm M42x2 G 1 50 mm	320 mm M48x2 G 1 63 mm
Stroke 25	R480634923	R480627379	R480627475	R480627559
50	R480627308	R480627380	R480627476	R480627560
80	R480627309	R480627381	R480627477	R480627561
100	R480627310	R480627382	R480627478	R480627562
125	R480627311	R480627383	R480627479	R480627563
160	R480627312	R480627384	R480627480	R480627564
200	R480627313	R480627385	R480627481	R480627565
250	R480627314	R480627386	R480627482	R480627566
320	R480627315	R480627387	R480627483	R480627567
400	R480627316	R480627388	R480627484	R480627568
500	R480627317	R480627389	R480627485	R480627569

## Technical data

Piston Ø	160 mm	200 mm	250 mm	320 mm
Retracting piston force	11875 N	19000 N	29688 N	48704 N
Extracting piston force	12667 N	19792 N	30925 N	50668 N
Cushioning length	46 mm	46 mm	56 mm	56 mm
Cushioning energy	160 J	170 J	180 J	190 J
Weight 0 mm stroke	12.5 kg	15.67 kg	25.87 kg	46.89 kg
Weight +10 mm stroke	0.21 kg	0.21 kg	0.38 kg	0.61 kg
Stroke max.	2700 mm	2700 mm	2500 mm	2500 mm

## Technical information

The pressure dew point must be at least 15 °C under ambient and medium temperature and may not exceed 3 °C .

The oil content of compressed air must remain constant during the life cycle.

Use only the approved oils from AVENTICS. Further information can be found in the "Technical information" document (available in the MediaCentre).

## Technical information

Material	
Cylinder tube	Aluminum, anodized
Piston rod	Stainless steel
Front cover	Die-cast aluminum
End cover	Die-cast aluminum
Seal	Fluorocaoutchouc
Nut for piston rod	Steel, galvanized
Scraper	Fluorocaoutchouc
Tie-rods	Stainless steel

## Dimensions

### Dimensions

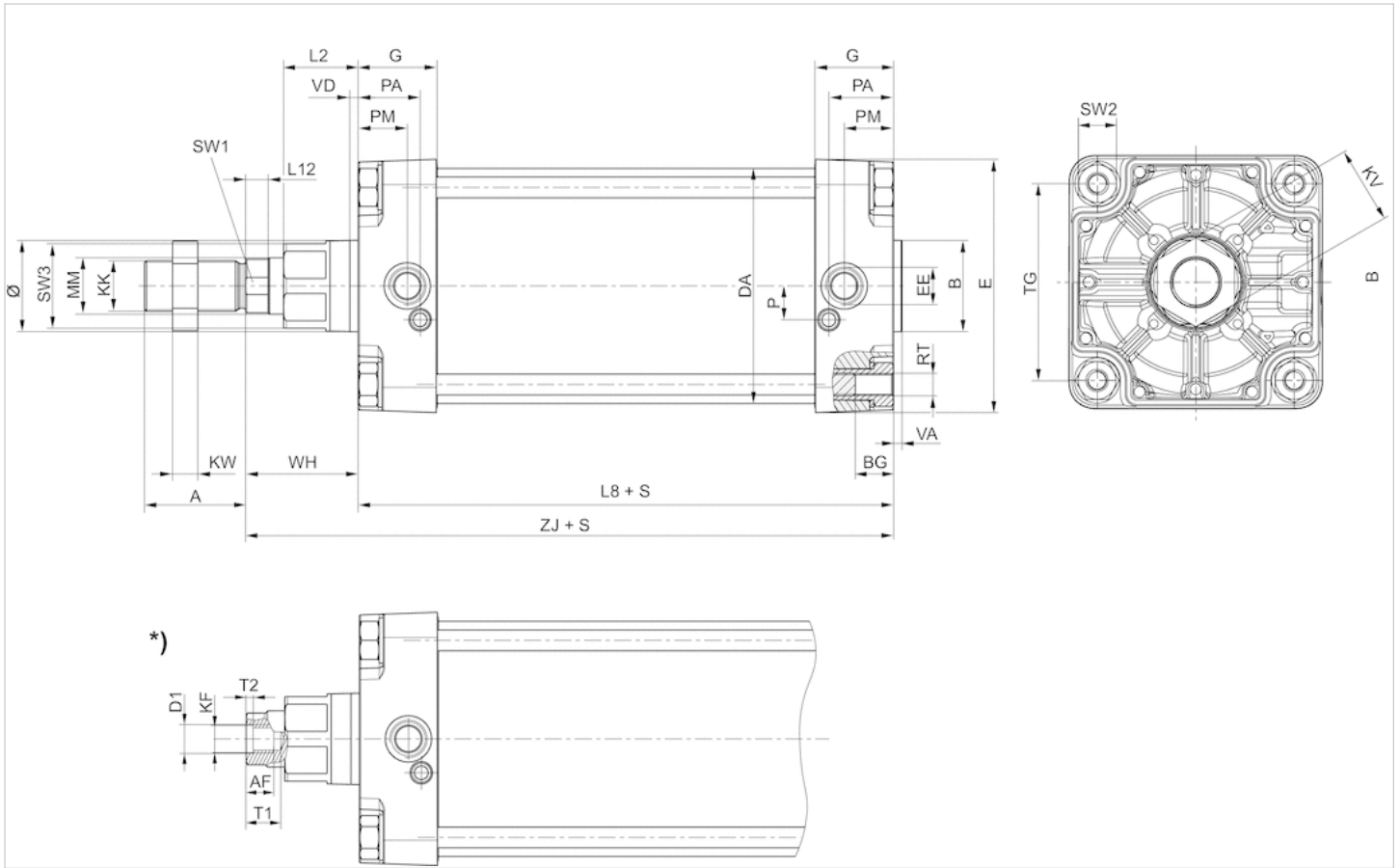

S = stroke

\*) For cylinders with optional piston rod with internal thread

## Dimensions

Piston Ø	A	B	ØB	BG	DA	E	EE	G	KK	KV	KW	L2	L8	L12	MM	P	PA	PM	RT
160 mm	72	65	65	24	167	180	G 3/4	56	M36x2	55	18	53	180	16	40	24	45	35	M16
200 mm	72	75	75	24	210	220	G 3/4	54	M36x2	55	18	56	180	16	40	22.5	42	30	M16
250 mm	84	90	90	25	262	280	G 1	59.5	M42x2	65	21	67	200	20	50	29	46	32.8	M20
320 mm	96	110	110	28	336	350	G 1	61.5	M48x2	75	24	76	220	23.25	63	30	48	37	M24

Piston Ø	SW1	SW2	SW3	TG	VA	VD	WH	ZJ
160 mm	36	27	60	140	6	6	80	260
200 mm	36	27	60	175	6	6	95	275
250 mm	46	41	80	220	10	31	105	305.3
320 mm	55	50	95	270	10	34	120	340.5

## Diagrams

### Cushioning diagram

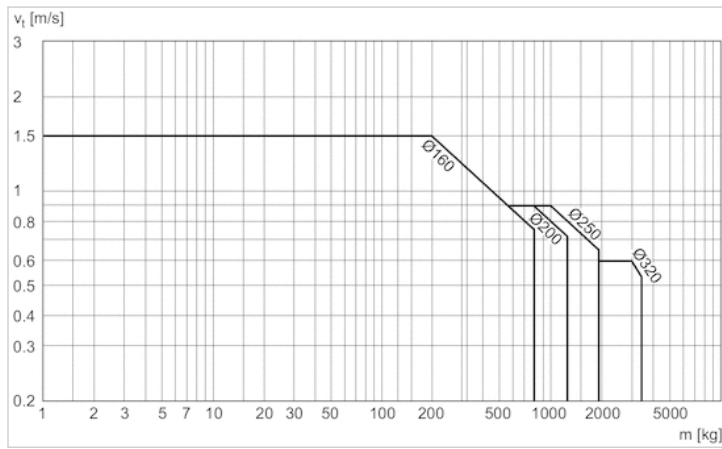

$v$  = Piston velocity [m/s]

$m$  = Cushionable mass [kg]



# Accessories overview

## Overview drawing

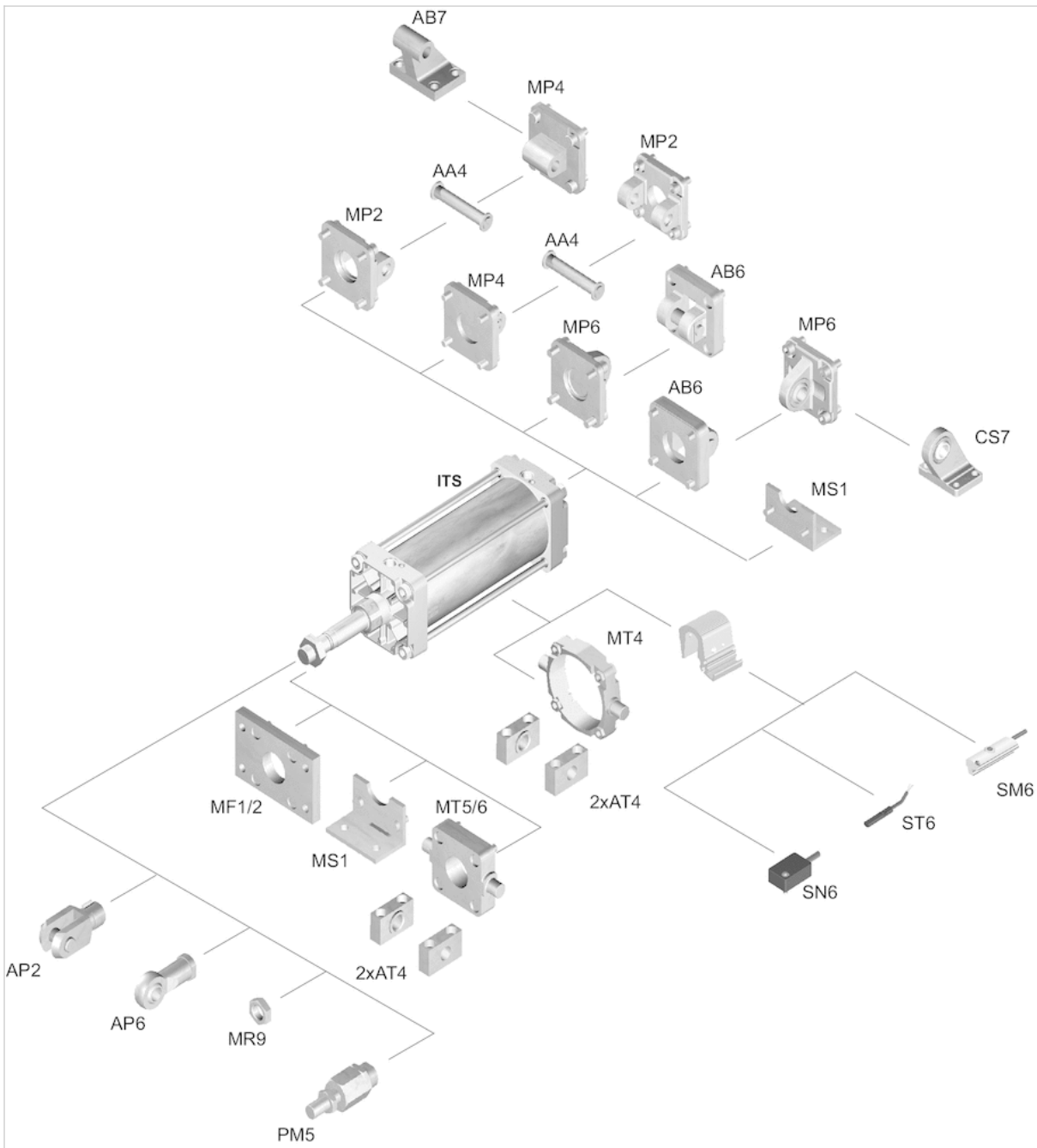

**NOTE:**

This overview drawing is only for orientation to indicate where the various accessory parts can be fastened to the cylinder. The illustration has been simplified for this purpose. It is thus not possible to derive the dimensions from this overview.

# Tie rod cylinder ISO 15552, Series ITS

- Ø 160-200 mm
- Ports G 3/4
- double-acting
- with magnetic piston
- Cushioning pneumatically adjustable
- Piston rod External thread
- Piston rod protection Bellows

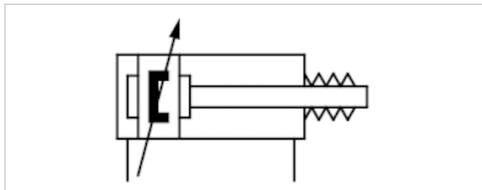

Standards	ISO 15552
Compressed air connection	Internal thread
Working pressure min./max.	2 ... 10 bar
Ambient temperature min./max.	-20 ... 80 °C
Medium temperature min./max.	-20 ... 80 °C
Medium	Compressed air
Max. particle size	50 µm
Oil content of compressed air	0 ... 5 mg/m <sup>3</sup>
Pressure for determining piston forces	6.3 bar

## Technical data

Piston Ø Piston rod thread Ports Piston rod Ø	160 mm M36x2 G 3/4 40 mm	200 mm M36x2 G 3/4 40 mm
Stroke 25	R481604436	R481604447
50	R481604437	R481604448
80	R481604438	R481604449
100	R481604439	R481604450
125	R481604440	R481604451
160	R481604441	R481604452
200	R481604442	R481604453
250	R481604443	R481604454
320	R481604444	R481604455
400	R481604445	R481604456
500	R481604446	R481604457

## Technical data

Piston Ø	160 mm	200 mm
Retracting piston force	11875 N	19000 N
Extracting piston force	12667 N	19792 N
Cushioning length	46 mm	46 mm
Cushioning energy	160 J	170 J
Speed max.	0.6 m/s	0.6 m/s
Stroke max.	1000 mm	1000 mm

## Technical information

The pressure dew point must be at least 15 °C under ambient and medium temperature and may not exceed 3 °C .

The oil content of compressed air must remain constant during the life cycle.

Use only the approved oils from AVENTICS. Further information can be found in the "Technical information" document (available in the MediaCentre).

Clamping piece for magnetic field sensor necessary

## Technical information

Material	
Cylinder tube	Aluminum, anodized
Piston rod	Stainless steel
Front cover	Die-cast aluminum
End cover	Die-cast aluminum
Seal	Acrylonitrile butadiene rubber
Nut for piston rod	Steel, galvanized
Scraper	Acrylonitrile butadiene rubber
Tie-rods	Stainless steel
Bellow	Carboxylated nitrile rubber

## Dimensions

### Dimensions

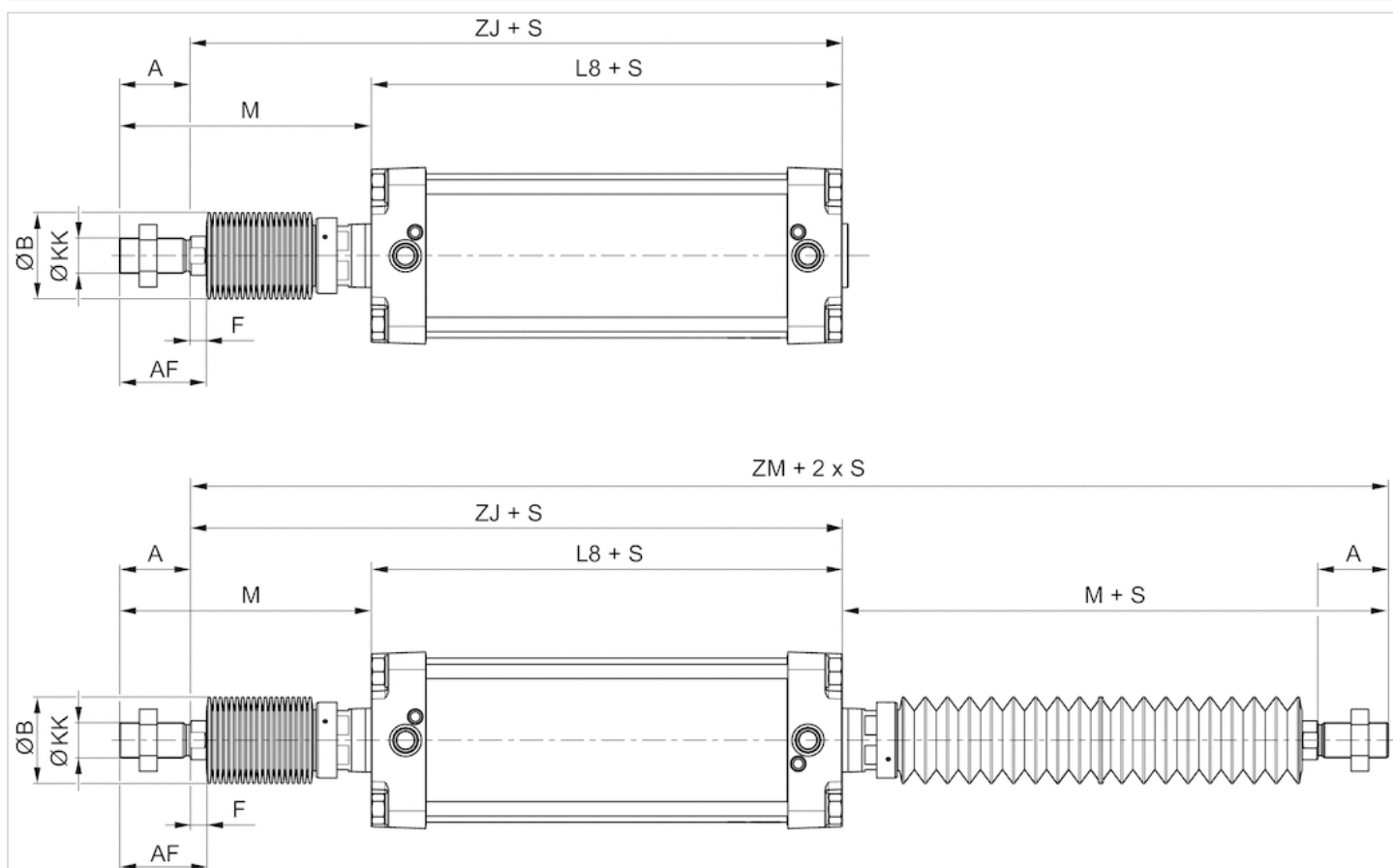

S = stroke

### Weight [kg]

Piston $\varnothing$	Stroke	Weight 0 mm stroke	Weight +10 mm stroke
160	0-150	13,39	0.21
160	151-300	14,03	0.21
160	301-450	14,67	0.21
160	451-600	15,31	0.21
160	601-750	15,96	0.21
160	751-1000	16,6	0.21
200	0-150	16,56	0.21
200	151-300	17,2	0.21
200	301-450	17,84	0.21
200	451-600	18,48	0.21
200	601-750	19,13	0.21
200	751-1000	19,77	0.21

## Dimensions

Piston Ø	A	Ø B	KK	L8	AF	F
160 mm	72	95	M36x2	180	88.7	16.7
200 mm	72	95	M36x2	180	88.7	16.7

## Stroke-dependent dimensions

Piston Ø	S=0-150 M	S=0-150 ZJ	S=0-150 ZM	S=151-300 M	S=151-300 ZJ
160 mm	206.5	314.5	449	256.5	364.5
200 mm	221.5	330	479	271.5	380

Piston Ø	S=151-300 ZM	S=301-450 M	S=301-450 ZJ	S=301-450 ZM
160 mm	499	306.5	414.5	549
200 mm	529	321.5	430	579

Piston Ø	S=451-600 M	S=451-600 ZJ	S=451-600 ZM	S=601-750 M
160 mm	356.5	464.5	599	406.5
200 mm	371.5	480	629	421.5

Piston Ø	S=601-750 ZJ	S=601-750 ZM	S=751-1000 M	S=751-1000 ZJ
160 mm	514.5	649	456.5	564.5
200 mm	530	679	471.5	580

Piston Ø	S=751-1000 ZM
160 mm	699
200 mm	729

S = stroke

## Diagrams

### Cushioning diagram

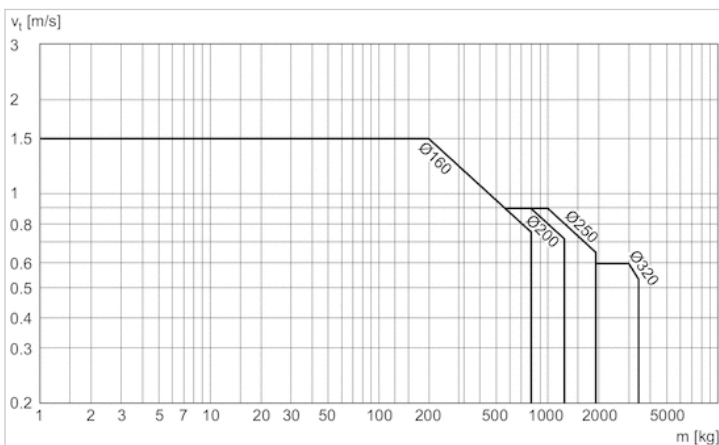

v = Piston velocity [m/s]

m = Cushionable mass [kg]

# Accessories overview

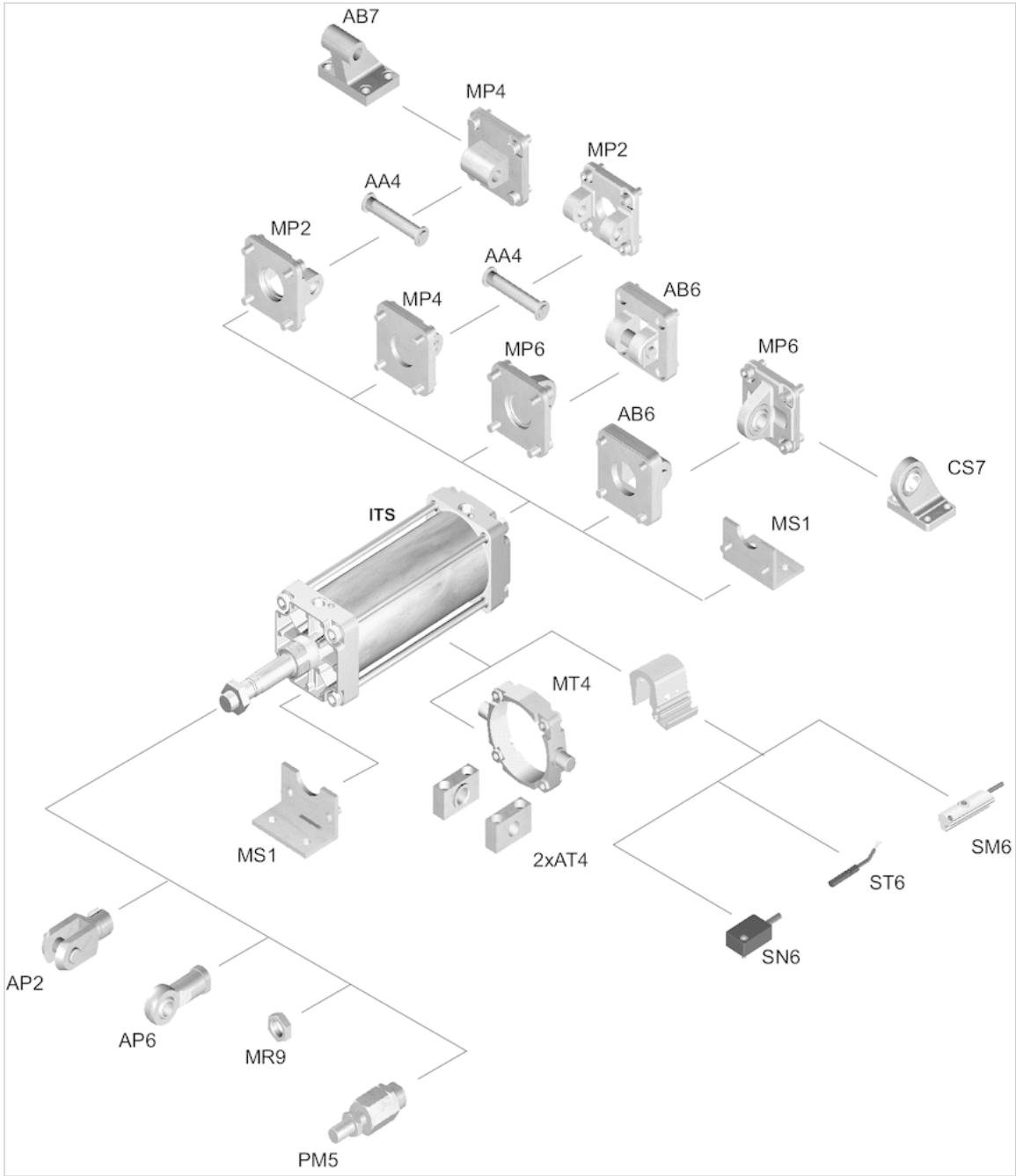

# Tie rod cylinder ISO 15552, Series ITS

- Ø 160-320 mm
- Ports G 3/4 G 1
- double-acting
- with magnetic piston
- Cushioning pneumatically adjustable
- Piston rod External thread
- -40 °C cold-resistant

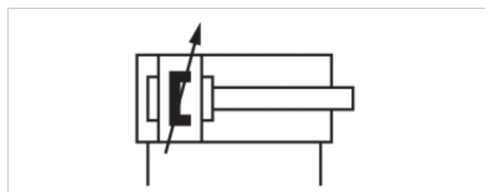

Standards	ISO 15552
Compressed air connection	Internal thread
Working pressure min./max.	2 ... 10 bar
Ambient temperature min./max.	-40 ... 70 °C
Medium temperature min./max.	-40 ... 70 °C
Medium	Compressed air
Max. particle size	50 µm
Oil content of compressed air	0 ... 5 mg/m <sup>3</sup>
Pressure for determining piston forces	6.3 bar

## Technical data

Piston Ø Piston rod thread Ports Piston rod Ø	160 mm M36x2 G 3/4 40 mm	200 mm M36x2 G 3/4 40 mm	250 mm M42x2 G 1 50 mm	320 mm M48x2 G 1 63 mm
Stroke 25	R481604639	R481604650	R481604661	R481604672
50	R481604640	R481604651	R481604662	R481604673
80	R481604641	R481604652	R481604663	R481604674
100	R481604642	R481604653	R481604664	R481604675
125	R481604643	R481604654	R481604665	R481604676
160	R481604644	R481604655	R481604666	R481604677
200	R481604645	R481604656	R481604667	R481604678
250	R481604646	R481604657	R481604668	R481604679
320	R481604647	R481604658	R481604669	R481604680
400	R481604648	R481604659	R481604670	R481604681
500	R481604649	R481604660	R481604671	R481604682

## Technical data

Piston Ø	160 mm	200 mm	250 mm	320 mm
Retracting piston force	11875 N	19000 N	29688 N	48704 N
Extracting piston force	12667 N	19792 N	30925 N	50668 N
Cushioning length	46 mm	46 mm	56 mm	56 mm
Cushioning energy	160 J	170 J	180 J	190 J
Weight 0 mm stroke	12.5 kg	15.67 kg	25.87 kg	46.89 kg
Weight +10 mm stroke	0.21 kg	0.21 kg	0.38 kg	0.61 kg
Stroke max.	2700 mm	2700 mm	2500 mm	2500 mm

## Technical information

The pressure dew point must be at least 15 °C under ambient and medium temperature and may not exceed 3 °C .

The oil content of compressed air must remain constant during the life cycle.

Use only the approved oils from AVENTICS. Further information can be found in the "Technical information" document (available in the MediaCentre).

Clamping piece for magnetic field sensor necessary

## Technical information

Material	
Cylinder tube	Aluminum, anodized
Piston rod	Stainless steel
Front cover	Die-cast aluminum
End cover	Die-cast aluminum
Seal	Acrylonitrile butadiene rubber
Nut for piston rod	Steel, galvanized
Scraper	Polyurethane metal
Tie-rods	Stainless steel



## Dimensions

### Dimensions

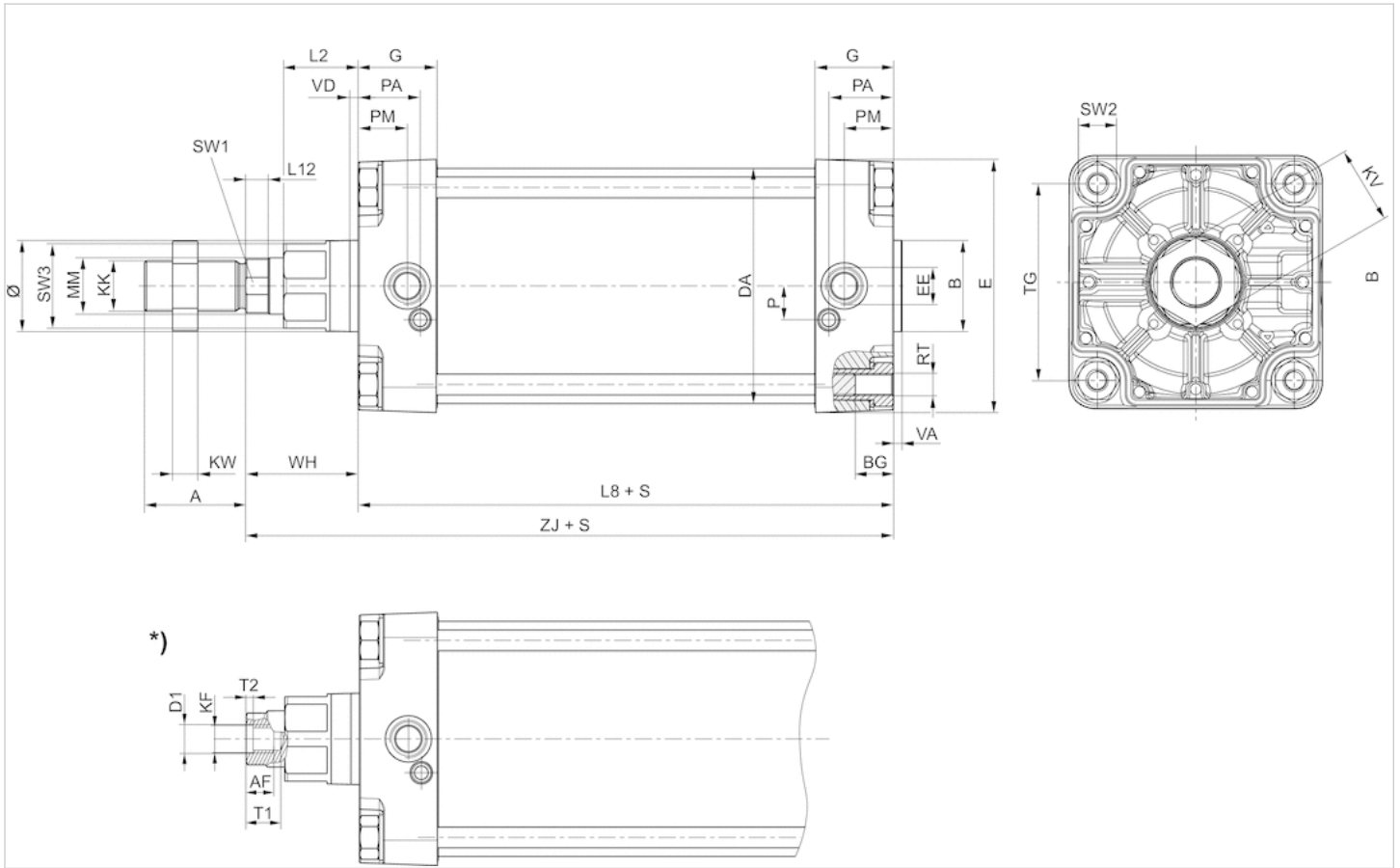

S = stroke

\*) For cylinders with optional piston rod with internal thread

## Dimensions

Piston Ø	A	AF	B	ØB	BG	D1	DA	E	EE	G	KF	KK	KV	KW	L2	L8	L12	MM	P	PA
160 mm	72	36	65	65	24	25	167	180	G 3/4	56	M24	M36x2	55	18	53	180	16	40	24	45
200 mm	72	36	75	75	24	25	210	220	G 3/4	54	M24	M36x2	55	18	56	180	16	40	22.5	42
250 mm	84	50	90	90	25	31	262	280	G 1	59.5	M30	M42x2	65	21	67	200	20	50	29	46
320 mm	96	55	110	110	28	37	336	350	G 1	61.5	M36	M48x2	75	24	76	220	23.25	63	30	48

Piston Ø	PM	RT	SW1	SW2	SW3	T1	T2	TG	VA	VD	WH	ZJ
160 mm	35	M16	36	27	60	40	10	140	6	6	80	260
200 mm	30	M16	36	27	60	40	10	175	6	6	95	275
250 mm	32.8	M20	46	41	80	60	10	220	10	31	105	305.3
320 mm	37	M24	55	50	95	65	13	270	10	34	120	340.5

## Diagrams

### Cushioning diagram

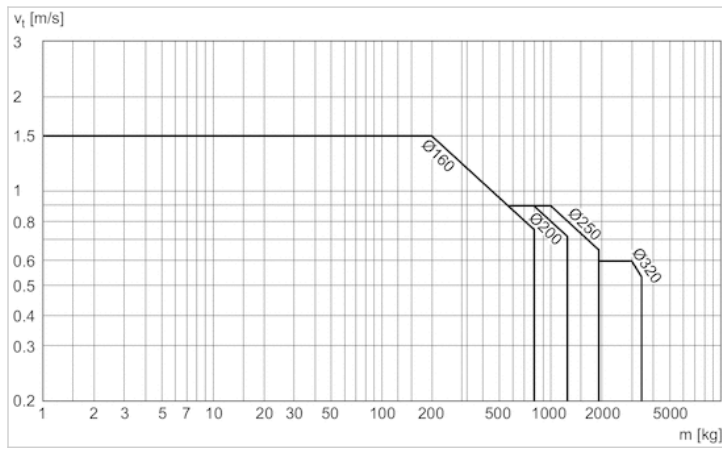

$v$  = Piston velocity [m/s]

$m$  = Cushionable mass [kg]

# Accessories overview

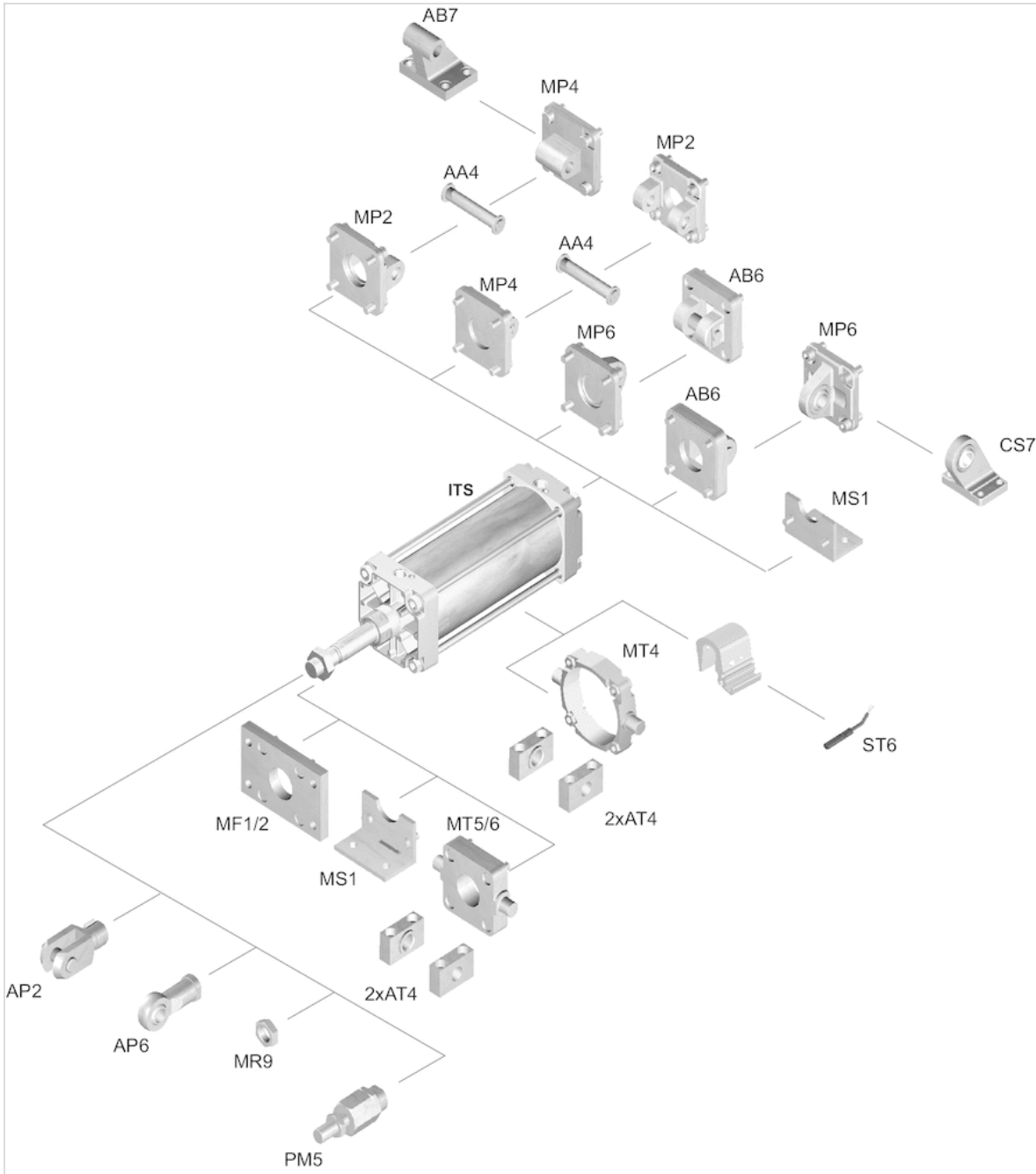

# Bearing block AB7-HD, Series CM1

- Suitable for robust mechanical engineering applications with fixed bearing
- Cylinder mounting in accordance with ISO 15552
- Suitable piston Ø 160 200 250 320 mm



Standards

ISO 15552

## Technical data

Part No.	Piston Ø	Swivel bearing Ø
1825805282	160 mm	30 mm
1825805283	200 mm	30 mm
1825805284	250 mm	40 mm
5239013422	320 mm	45 mm

## Technical information

Material	
Material	Nodular graphite iron galvanized
Screws	galvanized steel

## Dimensions

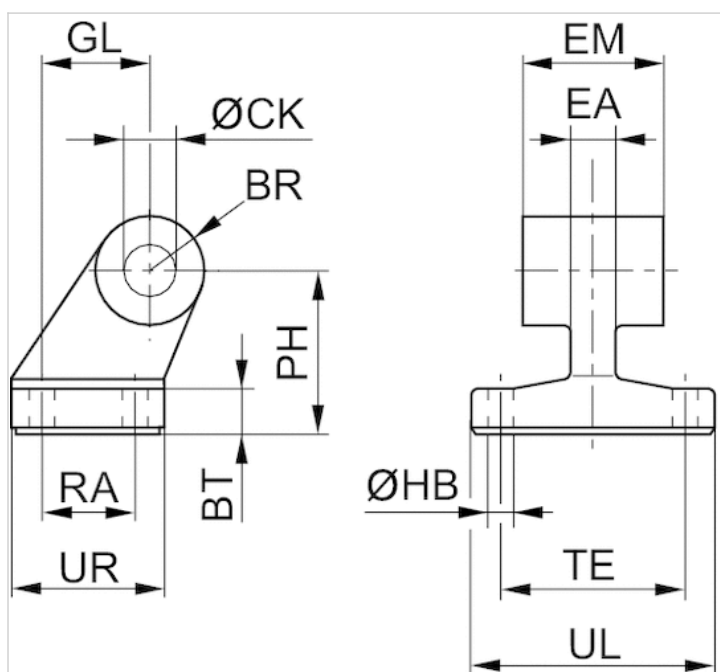

## Dimensions

Part No.	Piston Ø	BR	BT	Ø CK H9	Ø HB H13	EM	GL JS14	EA max.	PH JS15
1825805282	160 mm	31.5	25	30	14	90 -0,5/-1,5	97	36	115
1825805283	200 mm	31.5	30	30	18	90 -0,5/-1,5	105	40	135
1825805284	250 mm	40	35	40	22	110 -0,5/-1,5	128	45	165
5239013422	320 mm	45	40	45	26	120 -0,5/-1,5	150	55	200

RA JS14	TE JS14	UL max.	UR max.
88	118	156	126
90	122	162	130
110	150	200	160
122	170	234	186

# Bearing block CS7, Series CM1

- With ball joint and foot
- Cylinder mounting in accordance with VDMA 24562 part 2
- Suitable piston Ø 160 200 250 320 mm



Standards

VDMA 24562 part 2

## Technical data

Part No.	Piston Ø	Swivel bearing Ø
1827001791	160 mm	35 mm
1827001792	200 mm	35 mm
1827001793	250 mm	40 mm
5239013442	320 mm	40 mm

## Technical information

Material	
Material	Nodular graphite iron galvanized

## Dimensions

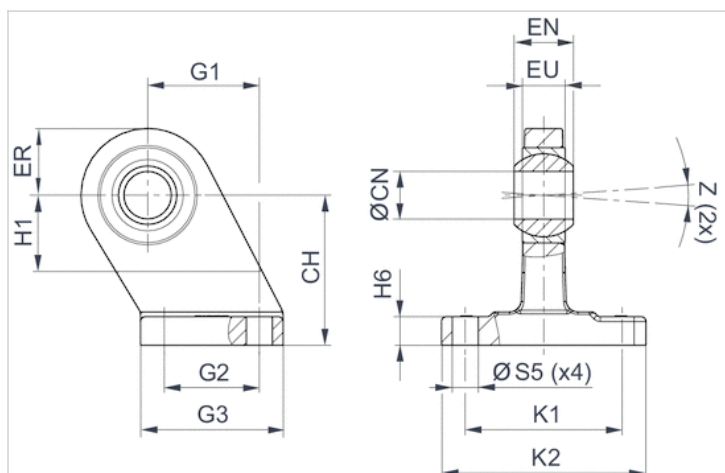

## Dimensions

Part No.	Piston Ø	CH JS15	ØCN H7	EU max.	EN -1,0	ER max.	G1 JS14	G2 JS14	G3 max.
1827001791	160 mm	115	35	28	43	44	97	88	126
1827001792	200 mm	135	35	28	43	47	105	90	130
1827001793	250 mm	165	40	33	49	53	128	110	160
5239013442	320 mm	200	50	45	60	63	150	122	186

H1 min.	H6	K1 JS14	K2 max.	ØS5 H13	Z min.
45	22 ±1,5	118	156	14	4°
45	27 ±2	122	162	18	4°
50	31 ±2	150	200	22	4°
60	36 ±2	170	234	26	4°

# Clevis mounting AB6, Series CM1

- Cylinder mounting in accordance with ISO 15552

- Suitable piston Ø 160 200 250 320 mm



Standards

ISO 15552

## Technical data

Part No.	Piston Ø	Swivel bearing Ø
1827001600	160 mm	35 mm
1827001601	200 mm	35 mm
1827001602	250 mm	40 mm
5239013432	320 mm	50 mm

Scope of delivery: clevis mounting incl. pivot pins and mounting screws

## Technical information

Material	
Material	Nodular graphite iron
	galvanized
Screws	Steel
	galvanized



## Dimensions

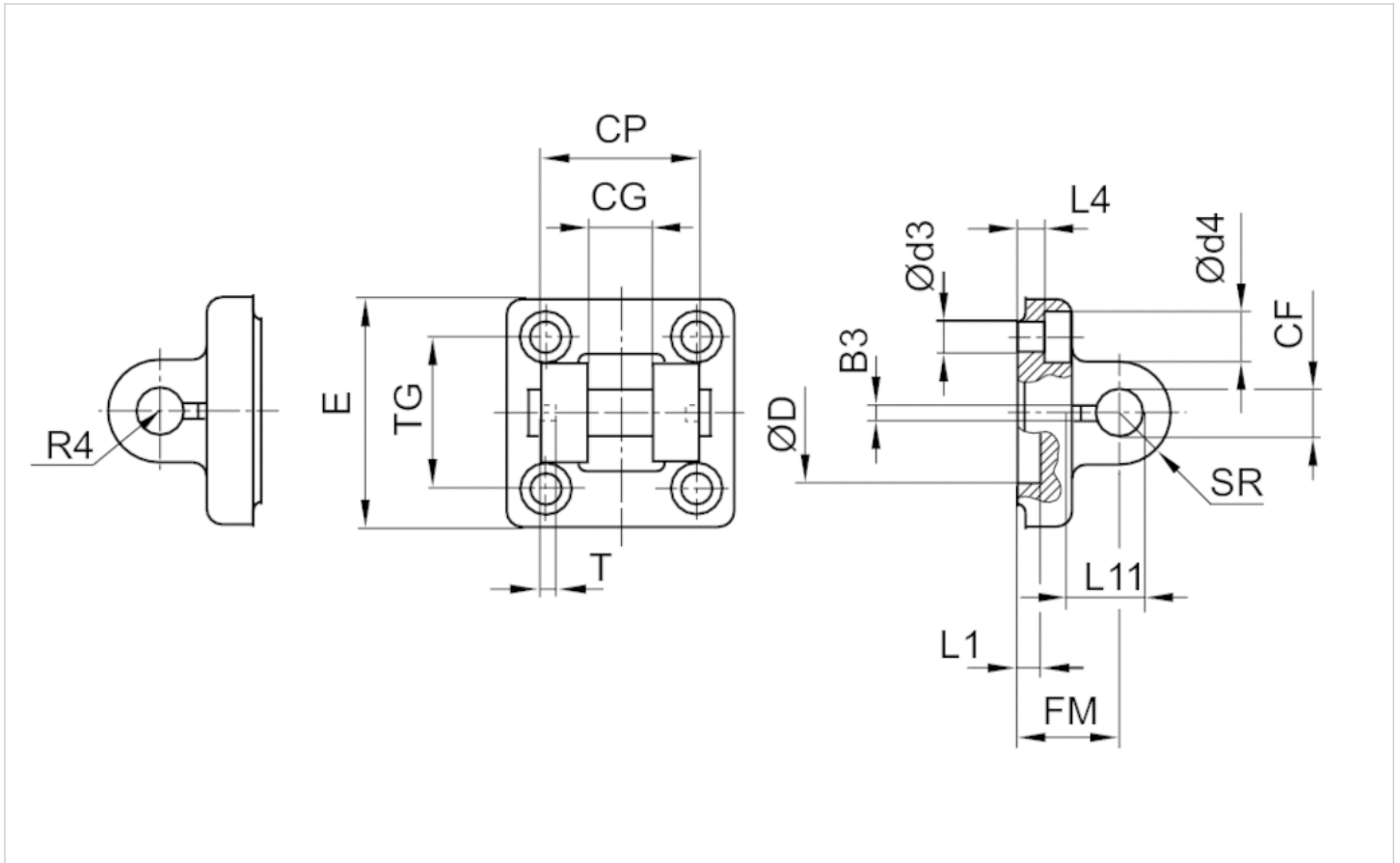

## Dimensions

Part No.	Piston Ø	B3 ±0,2	Ø CF F7	CG D10	CP d12	Ø d3	Ø d4	Ø D	E	FM ±0,2
1827001600	160 mm	6.3	35	43	122	18	26	65	180	55
1827001601	200 mm	6.3	35	43	122	18	26	75	220	60
1827001602	250 mm	8.3	40	49	125	22	33	90	280	70
5239013432	320 mm	8.3	50	60	150	26	36	110	340	80

L1 min.	L4 ±0,5	L11 -0,5	R4	SR	T ±0,2	TG
10	10	45	46	32.5	6	140 ±0,3
10	11	45	49	32.5	6	175 ±0,3
12	11	53	55	40	8	220 ±0,3
11	15	69	65	50	8	270 ±0,3

# Clevis mounting MP2-HD, Series CM1

- Suitable for robust mechanical engineering applications
- Cylinder mounting in accordance with ISO 15552
- Suitable piston  $\varnothing$  160 200 250 320 mm



Standards

ISO 15552

## Technical data

Part No.	Piston $\varnothing$	Swivel bearing $\varnothing$
1827004863	160 mm	30 mm
1827004864	200 mm	30 mm
1827004865	250 mm	40 mm
5239813402	320 mm	45 mm

Scope of delivery: clevis mounting incl. mounting screws

## Technical information

Material	
Material	Nodular graphite iron
	galvanized
Screws	Steel
	galvanized

## Dimensions

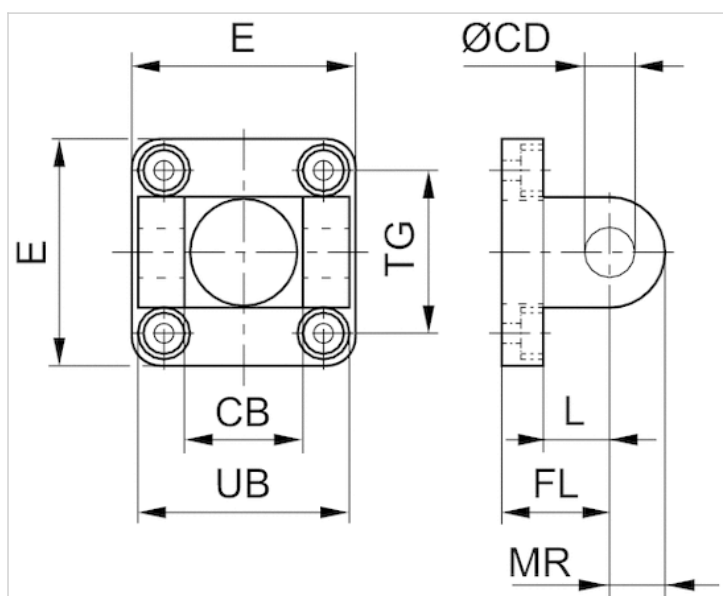

## Dimensions

Part No.	Piston $\varnothing$	CB H14	$\varnothing CD$ H9	E	FL $\pm 0.2$	L min.	MR max.	UB h13	TG
1827004863	160 mm	90	30	180	55	35	31	170	140 $\pm 0.3$
1827004864	200 mm	90	30	220	60	35	31	170	175 $\pm 0.3$
1827004865	250 mm	110	40	280	70	45	41	200	220 $\pm 0.3$
5239813402	320 mm	120	45	350	80	50	45	220	270 $\pm 0.3$

# Rear eye MP4-HD, Series CM1

- Suitable for robust mechanical engineering applications ■ for clevis mounting MP2 and AB3
- Cylinder mounting in accordance with ISO 15552
- Suitable piston Ø 160 200 250 320 mm



Standards

ISO 15552

## Technical data

Part No.	Piston Ø	Swivel bearing Ø
1827004867	160 mm	30 mm
1827004868	200 mm	30 mm
1827004869	250 mm	40 mm
5239813412	320 mm	45 mm

Scope of delivery: clevis incl. mounting screws

## Technical information

Material	
Material	Nodular graphite iron
	galvanized
Screws	Steel
	galvanized

## Dimensions

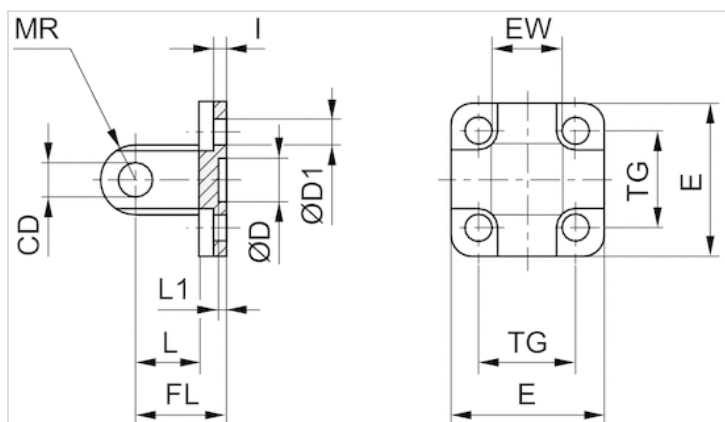

## Dimensions

Part No.	Piston Ø	CD H9	Ø D	Ø D1	E	EW	FL ±0,2	I ±0,5	L min.	L1 min.
1827004867	160 mm	30	65 H11	18	180	90 -0,5/-1,2	55	10	35	7
1827004868	200 mm	30	75 H11	18	220	90 -0,5/-1,2	60	11	35	7
1827004869	250 mm	40	90 H11	22	280	110 -0,5/-1,2	70	11	45	11
5239813412	320 mm	45	110 H11	26	350	120 -0,5/-1,2	80	15	50	11

MR max.	TG
31	140 ±0,3
31	175 ±0,3
41	220 ±0,3
45	270 ±0,3

# Rear eye MP6, Series CM1

- With ball joint and foot
- Cylinder mounting in accordance with ISO 15552
- Suitable piston Ø 160 200 250 320 mm



Standards  
Weight

ISO 15552  
See table below

## Technical data

Part No.	Piston Ø	Swivel bearing Ø	Bearing material, inner ring	Bearing material, outer ring	Weight
1827001626	160 mm	35 mm	Stainless steel	Brass with PTFE coating	5.6 kg
1827001627	200 mm	35 mm	Stainless steel	Brass with PTFE coating	8.5 kg
1827001628	250 mm	40 mm	Stainless steel	Brass with PTFE coating	14.5 kg
5239013452	320 mm	50 mm	Stainless steel	Brass with PTFE coating	24.6 kg

Scope of delivery: clevis incl. mounting screws

## Technical information

Material	
Material	Nodular graphite iron (galvanized)
Screws	galvanized steel

## Dimensions

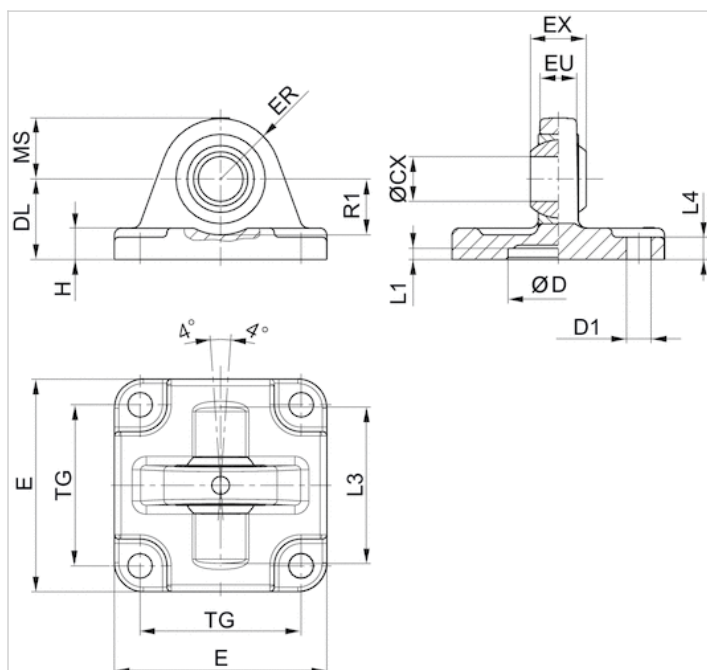

## Dimensions

Part No.	Piston Ø	ØCX H7	ØD H11	ØD1 H13	DL ±0,2	E	EX -0,1	ER	EU	H	L1 min.	L3
1827001626	160 mm	35	65	18	55	176	43	44	30	17	7	130
1827001627	200 mm	35	75	18	60	216	43	47	30	19.5	7	130
1827001628	250 mm	40	90	22	70	275	49	53	35	22	11	-
5239013452	320 mm	50	110	26	80	340	60	63	45	27	11	180

L4	MS -0,5	R1 min.	TG
10	44	39	140 ±0,3
11	47	41	175 ±0,3
11	53	45	220 ±0,3
15	63	55	270 ±0,3

# Trunnion mounting MT5, MT6, Series CM1

- for mounting to the cylinder cover or base
- Suitable piston Ø 160 200 250 mm
- for series ITS, TRB



Weight

See table below

The delivered product may vary from that in the illustration.

## Technical data

Part No.	Piston Ø	Weight
1827001616	160 mm	5.5 kg
1827001617	200 mm	9.7 kg
1827001618	250 mm	15.7 kg

Scope of delivery: trunnion mounting incl. mounting screws

## Technical information

Material	
Material	Nodular graphite iron
	galvanized
Screws	Steel
	galvanized



## Dimensions

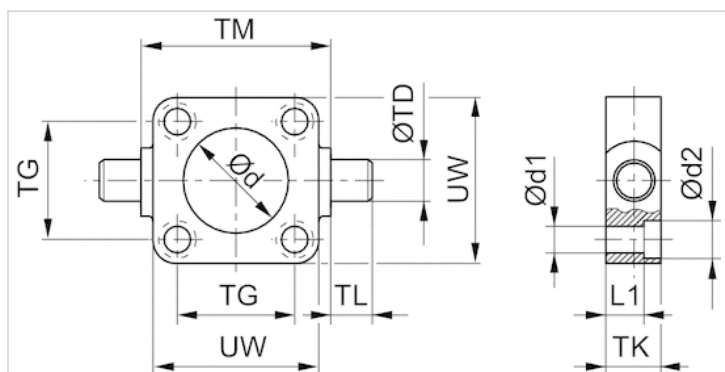

## Dimensions

Part No.	Piston $\varnothing$	$\varnothing d$ H11	$\varnothing d1$	$\varnothing d2$	L1	TD e9	TG $\pm 0,2$	TK	TL h14	TM h14	UW
1827001616	160 mm	65	18	26	38	32	140	50	32	200	184
1827001617	200 mm	75	18	26	40	32	175	60	32	250	224
1827001618	250 mm	90	22	33	57	40	220	70	40	320	286



## Dimensions

Part No.	Ø CR H8	EA	FA	FK ±0,1	FN	HB	NH	TH	UL
3671216000	32	66	32	70	103	17	32	140	172
3671220000	35	66	32	70	103	17	32	140	172

# Bearing AT4, Series CM1

- for trunnion mounting MT4, MT5, MT6
- Cylinder mounting in accordance with ISO 15552
- Suitable piston Ø 160, 200 250 320 mm
- for series ITS



Standards

ISO 15552

## Technical data

Part No.	Piston Ø	Swivel bearing Ø	Scope of delivery
1827001607	160, 200 mm	32 mm	2 piece
R412018908	250 mm	40 mm	2 piece
R412018903	320 mm	40 mm	2 piece

## Technical information

Material	
Material	Steel
	galvanized
Guide bushing	Sintered bronze

## Dimensions

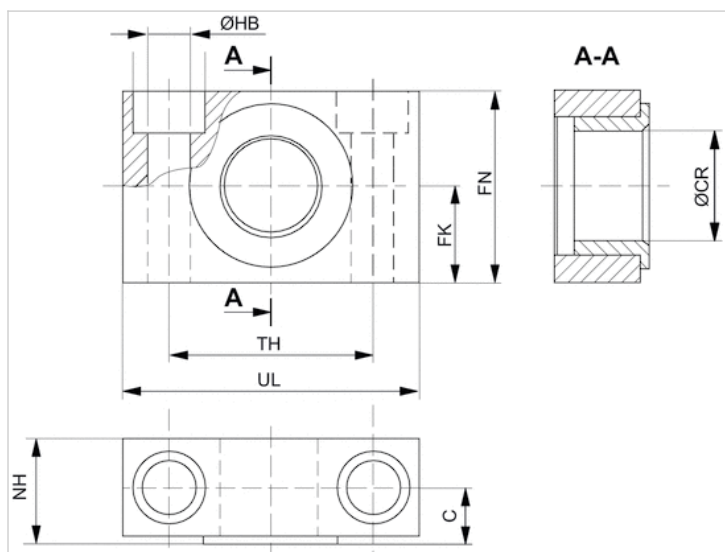

## Dimensions

Part No.	Piston Ø	UL	NH	TH	C	CR H9	HB H13	FN	FK	Plain bearing
1827001607	160, 200 mm	92	40	60 ±0,3	22.5	32	18	60	30 ±0,2	Sintered bronze
R412018908	250 mm	140	50	90	27.5	40	22	70	35	Sintered bronze
R412018903	320 mm	150	60	100	32.5	50	26	80	40	Sintered bronze

# Flange mounting MF1, MF2, Series CM1

- Cylinder mounting in accordance with ISO 15552

- Suitable piston Ø 160 200 250 320 mm



Standards

ISO 15552

## Technical data

Part No.	Piston Ø	Swivel bearing Ø
1827001460	160 mm	65 mm
1827001461	200 mm	75 mm
1827001462	250 mm	90 mm
5239016012	320 mm	110 mm

Scope of delivery: flange mounting incl. mounting screws

## Technical information

Material	
Material	Steel
	galvanized
Screws	Steel
	galvanized

## Dimensions

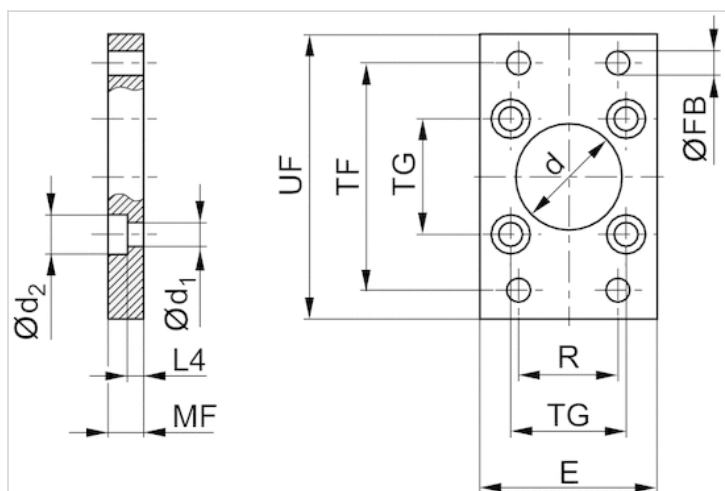

## Dimensions

Part No.	Piston Ø	Ød H11	Ød1	Ød2	E max.	ØFB	L4	MF	R	TF	TG	UF
1827001460	160 mm	65	18	26	180	18	9.5	20	115	230	140 ±0,3	275
1827001461	200 mm	75	18	26	220	22	12.5	25	135	270	175 ±0,3	312
1827001462	250 mm	90	22	33	280	26	10.5	25	165	330	220 ±0,3	380
5239016012	320 mm	110	26	40	350	33	15	30	200	270	270 ±0,3	400

# Foot mounting MS1, Series CM1

- to mount on cylinder PRA, TRB, CCL-IS/-IC, CCI, KPZ, 167, CVI, ITS
- Cylinder mounting in accordance with ISO 15552
- Suitable piston Ø 160 200 250 320 mm



Standards

ISO 15552

## Technical data

Part No.	Piston Ø	For series
1827001457	160 mm	ITS
1827001458	200 mm	ITS
1827001459	250 mm	ITS
5239010502	320 mm	ITS

Scope of delivery: 2 foot mountings incl. mounting screws

## Technical information

Material	
Material	Steel
	galvanized
Screws	Steel
	galvanized



## Dimensions

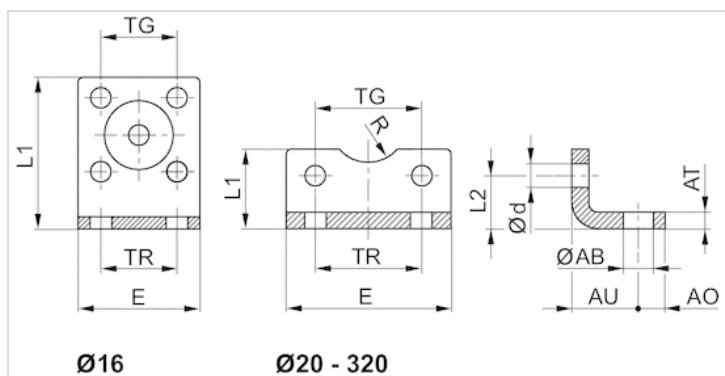

## Dimensions

Part No.	Piston Ø	ØAB	AO	AT	AU ±0,2	Ød	E	L1	L2	R	TG	TR
1827001457	160 mm	18.5	23	10 ±1,0	60	17.5	185	100	45	32.5	140 ±0,3	115
1827001458	200 mm	24	26	12 ±1,0	70	17.5	220	120	47.5	37.5	175 ±0,3	135
1827001459	250 mm	28	33	20 ±1,0	75	22	280	135	55	45	220 ±0,3	165
5239010502	320 mm	35	45	23 ±1,0	85	26	350	200	65	55	270 ±0,3	200

# Bolts AA4, Series CM1

- Cylinder mounting in accordance with ISO 15552

- Suitable piston Ø 160, 200 250 320 mm



Standards

ISO 15552

Weight

See table below

## Technical data

Part No.	Piston Ø	Weight	Fig.
5237000092	160, 200 mm	0.99 kg	Fig. 2
5239000092	250 mm	2.12 kg	Fig. 2
5239010092	320 mm	3.01 kg	Fig. 2

Scope of delivery: pivot pins incl. circlips

## Technical information

Material	
Material	Steel
	galvanized

## Dimensions

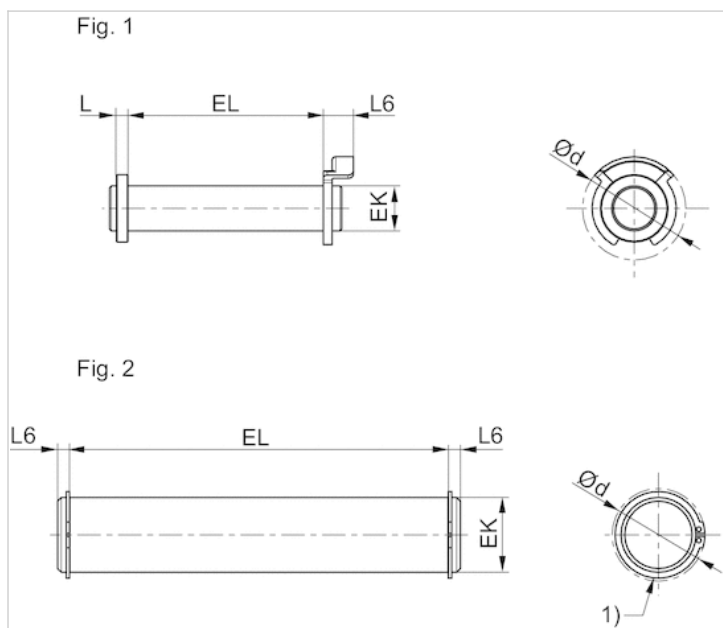

## Dimensions

Part No.	Piston Ø	Fig.	Ø d max.	EK e8	EL	L max.	L6 max.
5237000092	160, 200 mm	Fig. 2	40.5	30	172 +0,5	-	4.25
5239000092	250 mm	Fig. 2	52.6	40	202 +0,5	-	6.75
5239010092	320 mm	Fig. 2	59.1	45	222 +0,5	-	7.25

# Piston rod nut MR9



Weight

See table below

## Technical data

Part No.	Suitable piston rod thread	Weight
8103190414	M36x2	0.175 kg
8103190424	M42x2	0.37 kg
8103190434	M48x2	0.4 kg

## Technical information

Material	
	Steel
	galvanized

## Dimensions

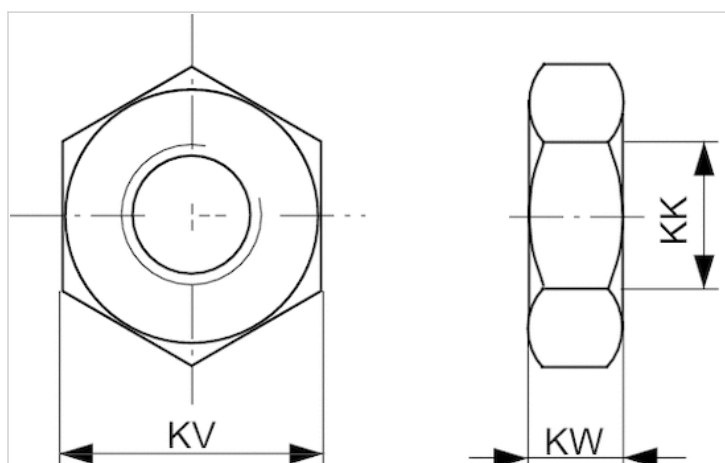

## Dimensions

Part No.	KK	KV	KW
8103190414	M36x2	50	16
8103190424	M42x2	60	21
8103190434	M48x2	65	25

# Rod clevis AP2, Series CM2

- to mount on cylinder PRA, TRB, CCI, MNI, ICM, KPZ, KHZ, 167, CVI, RPC, RDC, ITS



Weight

See table below

## Technical data

Part No.	Suitable piston rod thread	for	Weight	Fig.
1827001471	M36x2	ITS	3.5 kg	Fig. 2
1827001472	M42x2	ITS	6.6 kg	Fig. 2
8958019332	M48x2	ITS	9.7 kg	Fig. 1

## Technical information

### Material

Steel  
galvanized

## Dimensions

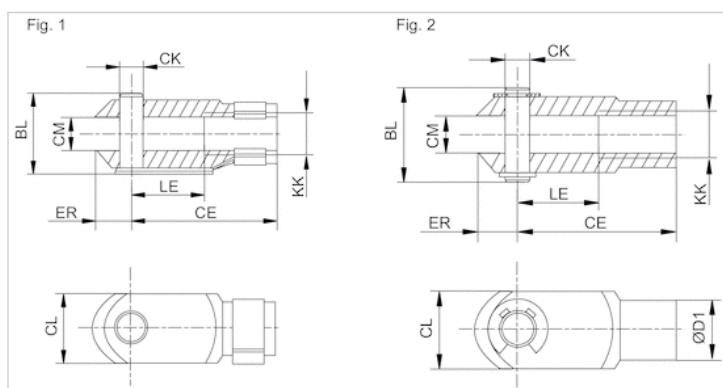

## Dimensions

Part No.	KK	BL	CE	ØCK e11	CL	CM	ØD1	ER	LE	Fig.
1827001471	M36x2	80	144	35	70	35	60	57	72	Fig. 2
1827001472	M42x2	98	168	40	85	40	70	64	84	Fig. 2
8958019332	M48x2	122	192	50	96	50	82	73	96	Fig. 1

# Ball eye rod end AP6, series CM2

- with flange to mount on cylinder PRA, TRB, CCI, SSI, MNI, RPC, KPZ, 167, CVI, RDC, 102, ITS



Weight

See table below

## Technical data

Part No.	Suitable piston rod thread	for	Swivel bearing Ø	Weight
1822124008	M36x2	ITS	889 mm	2 kg
1822124009	M42x2	ITS	1016 mm	3.4 kg
8958208842	M48x2	ITS	1270 mm	5.2 kg

## Technical information

Material	
	Steel
	galvanized



## Dimensions

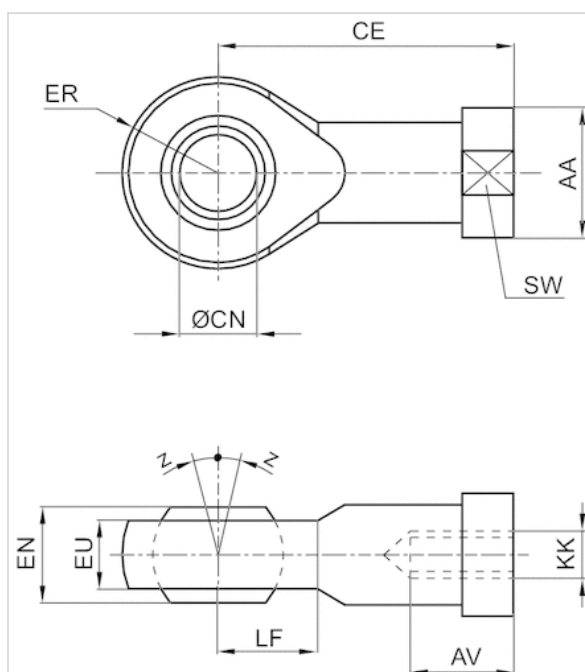

## Dimensions

Part No.	KK	AA	AV min.	CE	$\varnothing CN H7$	EN -0,1	ER	EU max.	LF	SW	Z [°] max.
1822124008	M36x2	60	56	125	35	43	40	32	40	50	4
1822124009	M42x2	69	60	142	40	49	45.5	37	45	55	4
8958208842	M48x2	75	65	160	50	60	58	45	60	65	6

# Compensating coupling PM5, series CM2

- to mount on cylinder PRA, TRB, CCL-IS/-IC, CCI, SSI, MNI, KPZ, KHZ, 167, CVI, RPC, RDC, ITS■spherical



Weight

See table below

## Technical data

Part No.	Suitable piston rod thread	for	Weight
1826409007	M36x2	ITS	5.4 kg
R412007729	M42x2	ITS	8.76 kg

## Technical information

Material	
	Steel
	galvanized

## Dimensions

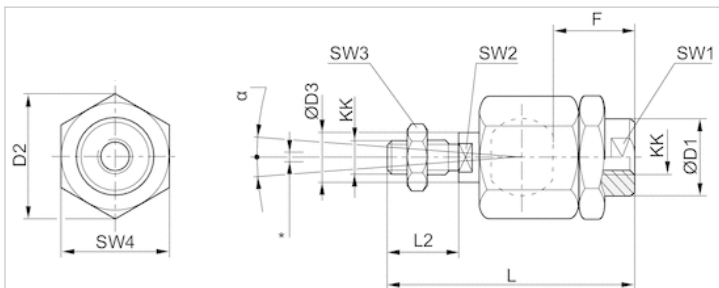

\* Radial joint

## Dimensions

Part No.	KK	Ø D1	D2	Ø D3	F	L ±2	L2	SW1	SW2	SW3	SW4	α [°]	1)	2)
1826409007	M36x2	80	80	38	86	241	72	50	36	55	75	8	0.05-0.2	0-2
R412007729	M42x2	64	98	42	96	271	82	60	36	65	85	8	0.05-0.2	0-2

1) Axial play

2) Radial play

# Compensating coupling PM7, series CM2

- to mount on cylinder PRA, TRB, CCL-IS/-IC, CCI, SSI, KPZ, 167, CVI, RPC, ITS with plate



Weight

3.4 kg

## Technical data

Part No.	Suitable piston rod thread	for
1827001634	M36x2	ITS

## Technical information

Material	
	Steel
	galvanized

## Dimensions

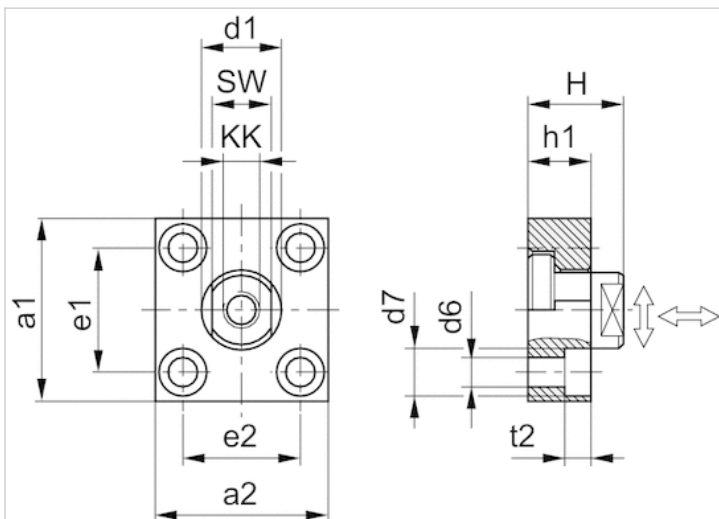

## Dimensions

Part No.	a1	a2	d1 h11	d6 H13	d7 H13	e1 H13	e2	h1	t2	H	SW
1827001634	125	125	60	18	26	90 ±0,3	90 ±0,3	30	17	55	50
Tightening torque for the coupling pin $M_a \pm 5\%$				Axial play min./max.			Radial play min./max.				
1080 Nm				0.4 0.95 mm			2.8 3.4 mm				

# Modular sealing system

- Ø 160 mm ... 320 mm

- For series ITS

- Piston Ø 160, 200 250 320 mm



Working pressure min./max.

1.5 ... 10 bar

Ambient temperature min./max.

See table below

Medium

Compressed air

Oil content of compressed air

0 ... 5 mg/m<sup>3</sup>

## Technical data

Part No.	Piston Ø	Piston rod seal	Scraper
R412018749	160, 200 mm	Acrylonitrile butadiene rubber	Acrylonitrile butadiene rubber
R412018750	160, 200 mm	Polyurethane	Brass
R412018751	160, 200 mm	Fluorocaoutchouc	Fluorocaoutchouc
R412018752	160, 200 mm	Fluorocaoutchouc	Brass
R412022884	160, 200 mm	Polytetrafluorethylene	Polytetrafluorethylene
R412018753	250 mm	Acrylonitrile butadiene rubber	Acrylonitrile butadiene rubber
R412018754	250 mm	Polyurethane	Brass
R412018755	250 mm	Fluorocaoutchouc	Fluorocaoutchouc
R412018756	250 mm	Fluorocaoutchouc	Brass
R412022885	250 mm	Polytetrafluorethylene	Polytetrafluorethylene
R412018757	320 mm	Acrylonitrile butadiene rubber	Acrylonitrile butadiene rubber
R412018758	320 mm	Polyurethane	Brass
R412018759	320 mm	Fluorocaoutchouc	Fluorocaoutchouc
R412018760	320 mm	Fluorocaoutchouc	Brass
R412022886	320 mm	Polytetrafluorethylene	Polytetrafluorethylene

Part No.	Ambient temperature min./max.
R412018749	-20 ... 80 °C
R412018750	-40 ... 80 °C
R412018751	-10 ... 150 °C
R412018752	-10 ... 150 °C
R412022884	-20 ... 150 °C
R412018753	-20 ... 80 °C
R412018754	-40 ... 80 °C
R412018755	-10 ... 150 °C
R412018756	-10 ... 150 °C
R412022885	-20 ... 150 °C

Part No.	Ambient temperature min./max.
R412018757	-20 ... 80 °C
R412018758	-40 ... 80 °C
R412018759	-10 ... 150 °C
R412018760	-10 ... 150 °C
R412022886	-20 ... 150 °C

Application area Chemical industry Sugar production Steel construction Automotive industry Woodworking industry

## Technical information

Material	
Housing	Aluminum, anodized
Scraper	Acrylonitrile butadiene rubber Brass Fluorocaoutchouc Polytetrafluorethylene
Piston rod seal	Acrylonitrile butadiene rubber Polyurethane Fluorocaoutchouc Polytetrafluorethylene

## Dimensions

### Dimensions

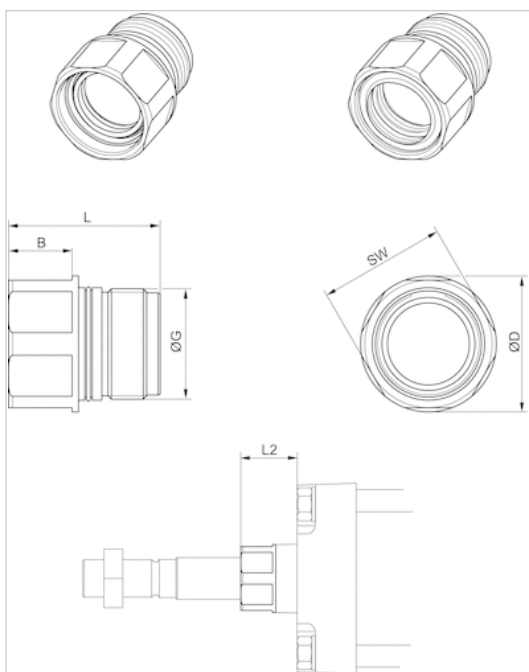

### Dimensions

Ø	B	ØD	G	L	L2	SW
160, 200	30	64	M52x3	71.5	56	60
250	31.5	88	M70x4	85.5	67	80
320	37	108	M85x4	97	76	95

# Sensor, Series ST6

- 6 mm T-slot
- with cable
- open cable ends, 3-pin
- ATEX
- UL certification, ATEX
- electronic PNP
- Direct mounting for series PRA, PRE, CCI, KPZ, SSI, GPC, CVI
- Indirect mounting for series TRB, ITS, CCL-IS, MNI, CSL-RD, RPC, ICS-D2, ICM, KHZ, TRR

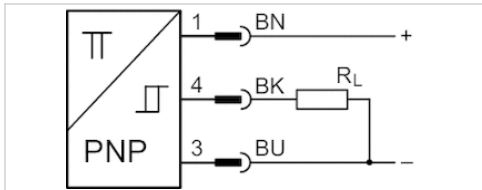

### Certificates

ATEX class G	ATEX CE declaration of conformity cULus
ATEX class D	RoHS
Ambient temperature min./max.	II 3G Ex nA IIC T4 Gc X
Protection class	II 3D Ex tc IIIC T135°C Dc X
Switching point precision	-20 ... 50 °C
Quiescent current (without load)	IP67
Min./max. DC operating voltage	±0,1 mT
Switching logic	10 mA
LED status display	10 ... 30 V DC
Vibration resistance	NO (make contact)
Shock resistance	Yellow
Cable length L	10 - 55 Hz, 1 mm
	30 g / 11 ms
	3 5 m

## Technical data

Part No.	for	Type of contact	Cable length L
R412022854	PRA, PRE, CCI, KPZ, SSI, GPC, CVI	electronic PNP	3 m
R412022856	PRA, PRE, CCI, KPZ, SSI, GPC, CVI	electronic PNP	5 m

Part No.	Voltage drop U at I <sub>max</sub>	DC switching current, max.
R412022854	≤ 2,5 V	0.1 A
R412022856	≤ 2,5 V	0.1 A

Part No.	Max. switching frequency
R412022854	1000 Hz
R412022856	1000 Hz

Part No.	Version
R412022854	short circuit resistant Protected against polarity reversal



Part No.	Version
R412022856	short circuit resistant Protected against polarity reversal

## Technical information

Material	
Housing	Polyamide
Cable sheath	Polyurethane
Locking screw	Stainless steel

## Dimensions

Fig. 2

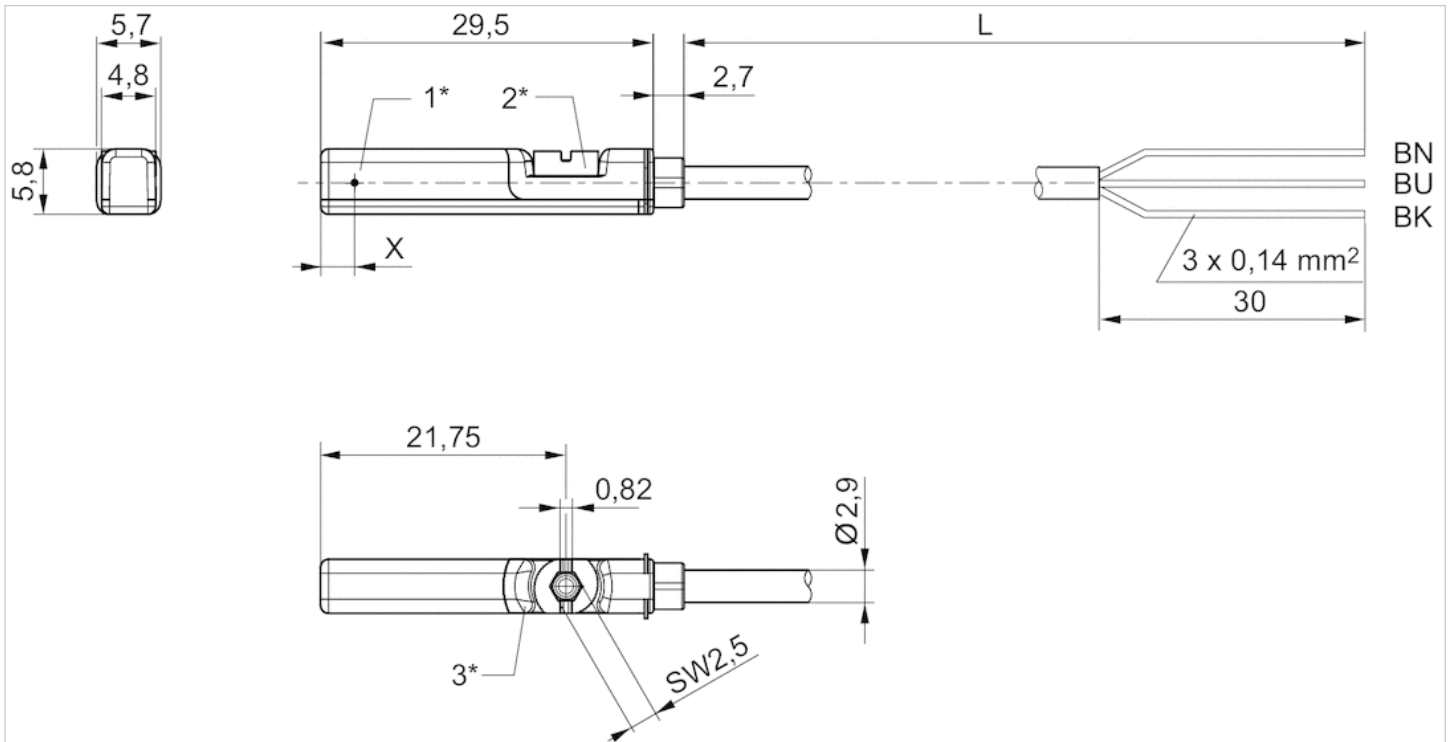

1\* = switching point 2\* = locking screw 3\* = LED window, transparent  
 L = cable length  
 BN = brown, BK = black, BU = blue  
 X = electronic: 11.6 mm











## Sensor, Series ST6

- 6 mm T-slot
- with cable
- open cable ends, 2-pin open cable ends, 3-pin
- UL certification
- Reed electronic PNP electronic NPN
- Direct mounting for series PRA, PRE, CCI, KPZ, SSI, GPC, CVI
- Indirect mounting for series TRB, ITS, CCL-IS, MNI, CSL-RD, RPC, ICS-D2, ICM, KHZ, TRR



Ambient temperature min./max.	-30 ... 80 °C
Protection class	IP65, IP67, IP69K
Switching point precision	±0,1 mT
Nominal current, actuated state	30 mA
Quiescent current (without load)	8 mA
Min./max. DC operating voltage	See table below
Min./max. AC operating voltage	See table below
Hysteresis	≥ 0,2 mT
Switching logic	NO (make contact)
LED status display	Yellow
Vibration resistance	10 - 55 Hz, 1 mm
Shock resistance	30 g / 11 ms
Cable length L	3 5 10 m

## Technical data

Part No.		for	Type of contact
R412022866		PRA, PRE, CCI, KPZ, SSI, GPC, CVI	Reed
R412027170		PRA, PRE, CCI, KPZ, SSI, GPC, CVI	Reed
R412022869		PRA, PRE, CCI, KPZ, SSI, GPC, CVI	Reed
R412022870		PRA, PRE, CCI, KPZ, SSI, GPC, CVI	Reed
R412022871		PRA, PRE, CCI, KPZ, SSI, GPC, CVI	Reed
R412022853		PRA, PRE, CCI, KPZ, SSI, GPC, CVI	electronic PNP
R412022855		PRA, PRE, CCI, KPZ, SSI, GPC, CVI	electronic PNP
R412022857		PRA, PRE, CCI, KPZ, SSI, GPC, CVI	electronic PNP
R412022849		PRA, PRE, CCI, KPZ, SSI, GPC, CVI	electronic NPN
R412022850		PRA, PRE, CCI, KPZ, SSI, GPC, CVI	electronic NPN

Part No.	Cable length L	Min./max. DC operating voltage	Min./max. AC operating voltage
R412022866	3 m	10 ... 230 V DC	10 ... 230 V AC
R412027170	5 m	10 ... 230 V DC	10 ... 230 V AC
R412022869	3 m	10 ... 30 V DC	10 ... 30 V AC
R412022870	5 m	10 ... 30 V DC	10 ... 30 V AC
R412022871	10 m	10 ... 30 V DC	10 ... 30 V AC
R412022853	3 m	10 ... 30 V DC	-
R412022855	5 m	10 ... 30 V DC	-
R412022857	10 m	10 ... 30 V DC	-
R412022849	3 m	10 ... 30 V DC	-
R412022850	5 m	10 ... 30 V DC	-

Part No.	Voltage drop U at I <sub>max</sub>	DC switching current, max.
R412022866	≤ 3,5 V	0.13 A
R412027170	≤ 3,5 V	0.13 A
R412022869	I*Rs	0.3 A
R412022870	≤ 0,1 V	0.3 A
R412022871	I*Rs	0.3 A
R412022853	≤ 2,5 V	0.13 A
R412022855	≤ 2,5 V	0.13 A
R412022857	≤ 2,5 V	0.13 A
R412022849	≤ 2,5 V	0.13 A
R412022850	≤ 2,5 V	0.13 A

Part No.	AC switching current, max.	Switching capacity
R412022866	0.13 A	Reed, 2-pin: max. 10 W
R412027170	0.13 A	Reed, 2-pin: max. 10 W
R412022869	0.5 A	Reed, 3-pin: max. 6 W
R412022870	0.5 A	Reed, 3-pin: max. 6 W
R412022871	0.5 A	Reed, 3-pin: max. 6 W

Part No.	AC switching current, max.	Switching capacity
R412022853	-	-
R412022855	-	-
R412022857	-	-
R412022849	-	-
R412022850	-	-

Part No.	Max. switching frequency	Operating current, not switched
R412022866	400 Hz	-
R412027170	400 Hz	-
R412022869	400 Hz	-
R412022870	400 Hz	-
R412022871	400 Hz	-
R412022853	1000 Hz	8 mA
R412022855	1000 Hz	8 mA
R412022857	1000 Hz	8 mA
R412022849	1000 Hz	8 mA
R412022850	1000 Hz	8 mA

Part No.	Operating current, switched
R412022866	-
R412027170	-
R412022869	-
R412022870	-
R412022871	-
R412022853	30 mA
R412022855	30 mA
R412022857	30 mA
R412022849	30 mA
R412022850	30 mA

Part No.	Version	Fig.	
R412022866	Protected against polarity reversal	Fig. 1	1)
R412027170	Protected against polarity reversal	Fig. 1	1)
R412022869	Protected against polarity reversal	Fig. 2	2)
R412022870	Protected against polarity reversal	Fig. 2	2)
R412022871	Protected against polarity reversal	Fig. 2	2)
R412022853	short circuit resistant Protected against polarity reversal	Fig. 2	3)
R412022855	short circuit resistant Protected against polarity reversal	Fig. 2	3)
R412022857	short circuit resistant Protected against polarity reversal	Fig. 2	3)
R412022849	short circuit resistant Protected against polarity reversal	Fig. 2	3)
R412022850	short circuit resistant Protected against polarity reversal	Fig. 2	3)

1) open cable ends, 2-pin, The product of operating voltage and continuous current must not exceed the maximum switching capacity.

2) open cable ends, 3-pin, The product of operating voltage and continuous current must not exceed the maximum switching capacity.

3) open cable ends, 3-pin

## Technical information

No cULus certification for 230 V variant.

## Technical information

### Material

Housing	Polyamide
Cable sheath	Polyurethane
Locking screw	Stainless steel

## Dimensions

Fig. 1

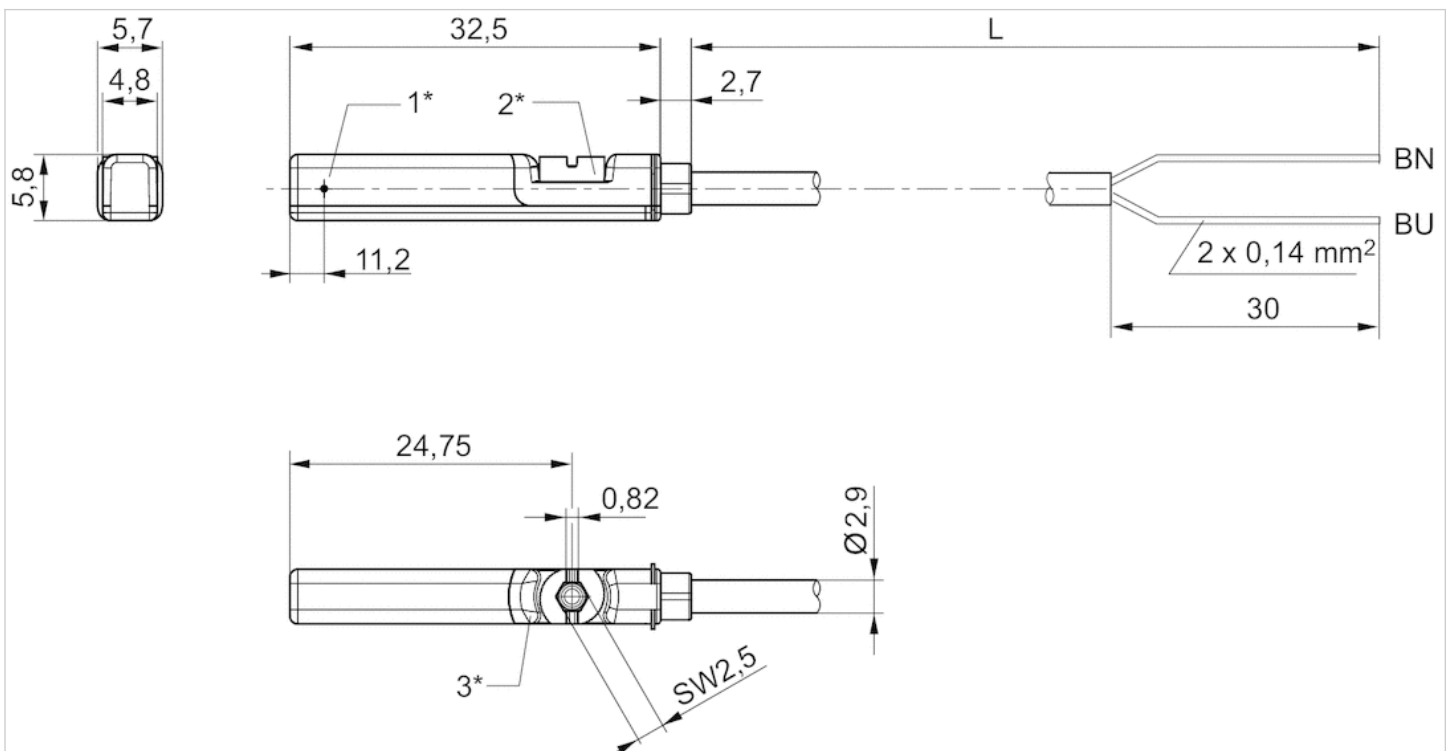

1\* = switching point 2\* = locking screw 3\* = LED window, transparent

L = cable length

BN=brown, BU=blue

Fig. 2

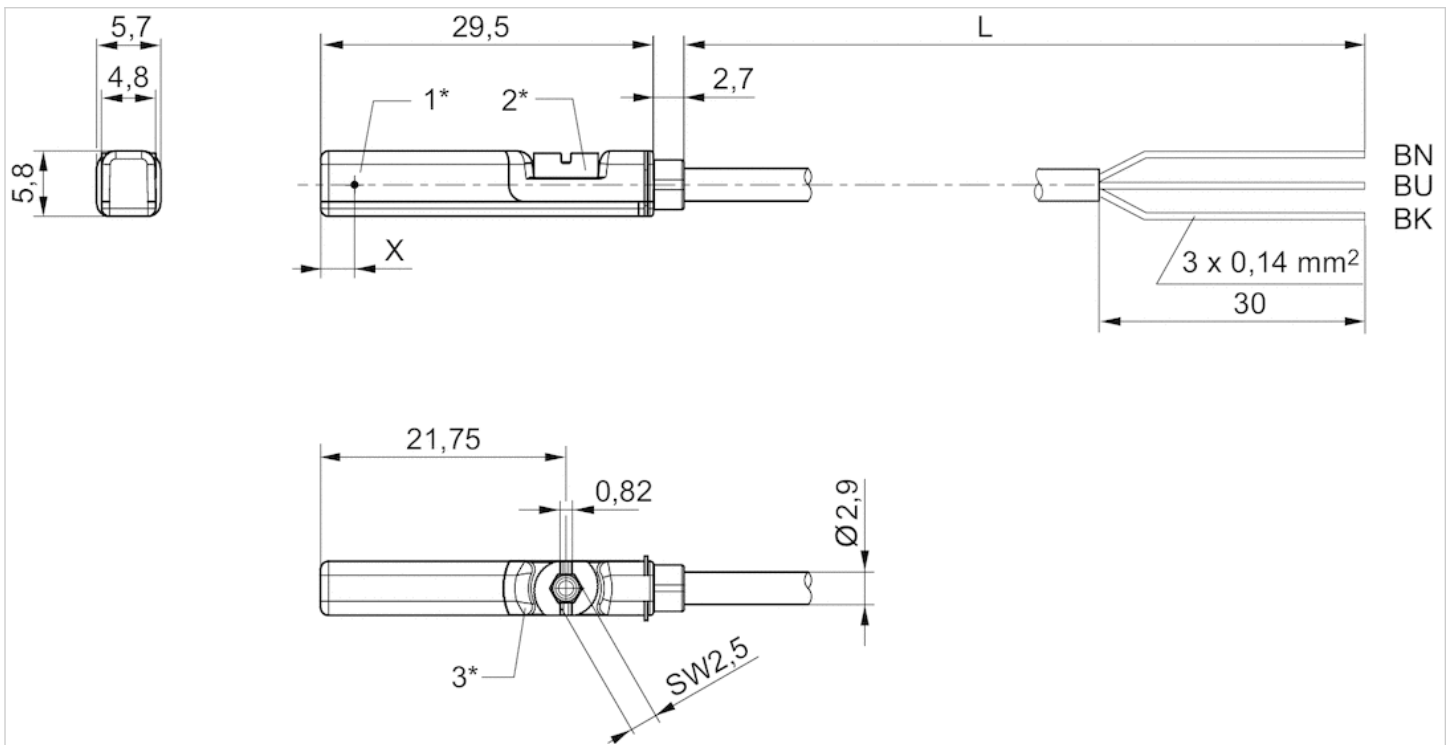

1\* = switching point 2\* = locking screw 3\* = LED window, transparent  
 L = cable length  
 BN = brown, BK = black, BU = blue  
 X = electronic: 11.6 mm





# Sensor, Series ST6

- 6 mm T-slot
- with cable
- Plug, M8, 3-pin Plug, M8, 2-pin
- UL certification
- Reed electronic PNP electronic NPN
- Direct mounting for series PRA, PRE, CCI, KPZ, SSI, GPC, CVI
- Indirect mounting for series TRB, ITS, CCL-IS, MNI, CSL-RD, RPC, ICS-D2, ICM, KHZ, TRR



Certificates	CE declaration of conformity cULus RoHS
Ambient temperature min./max.	-30 ... 80 °C
Protection class	IP65, IP67
Switching point precision	±0,1 mT
Nominal current, actuated state	30 mA
Quiescent current (without load)	8 mA
Min./max. DC operating voltage	10 ... 30 V DC
Min./max. AC operating voltage	See table below
Hysteresis	≥ 0,2 mT
Switching logic	NO (make contact)
LED status display	Yellow
Vibration resistance	10 - 55 Hz, 1 mm
Shock resistance	30 g / 11 ms
Cable length L	0.3 m

## Technical data

Part No.		for	Type of contact
R412022868		PRA, PRE, CCI, KPZ, SSI, GPC, CVI	Reed
R412027172		PRA, PRE, CCI, KPZ, SSI, GPC, CVI	Reed
R412022872		PRA, PRE, CCI, KPZ, SSI, GPC, CVI	Reed
R412022858		PRA, PRE, CCI, KPZ, SSI, GPC, CVI	electronic PNP
R412022851		PRA, PRE, CCI, KPZ, SSI, GPC, CVI	electronic NPN

Part No.	Cable length L	Min./max. AC operating voltage	Voltage drop U at I <sub>max</sub>
R412022868	0.3 m	10 ... 30 V AC	≤ 3,5 V
R412027172	0.3 m	10 ... 30 V AC	≤ 3,5 V
R412022872	0.3 m	10 ... 30 V AC	≤ 0,1 V
R412022858	0.3 m	-	≤ 2,5 V
R412022851	0.3 m	-	≤ 2,5 V

Part No.	DC switching current, max.	AC switching current, max.
R412022868	0.13 A	0.13 A
R412027172	0.13 A	0.13 A
R412022872	0.3 A	0.5 A
R412022858	0.13 A	-

Part No.	DC switching current, max.	AC switching current, max.
R412022851	0.13 A	-

Part No.	Switching capacity	Max. switching frequency
R412022868	Reed, 2-pin: max. 10 W	400 Hz
R412027172	Reed, 2-pin: max. 10 W	400 Hz
R412022872	Reed, 3-pin: max. 6 W	400 Hz
R412022858	-	1000 Hz
R412022851	-	1000 Hz

Part No.	Operating current, not switched	Operating current, switched
R412022868	-	-
R412027172	-	-
R412022872	-	-
R412022858	8 mA	30 mA
R412022851	8 mA	30 mA

Part No.	Version	
R412022868	Protected against polarity reversal	1)
R412027172	Protected against polarity reversal	1)
R412022872	Protected against polarity reversal	1)
R412022858	short circuit resistant Protected against polarity reversal	-
R412022851	short circuit resistant Protected against polarity reversal	-

1) The product of operating voltage and continuous current must not exceed the maximum switching capacity.

## Technical information

Material	
Housing	Polyamide
Cable sheath	Polyurethane
Locking screw	Stainless steel





# Sensor, Series ST6

- 6 mm T-slot
- with cable
- Plug, M12, 3-pin, with knurled screw
- ATEX
- UL certification, ATEX
- electronic PNP
- Direct mounting for series PRA, PRE, CCI, KPZ, SSI, GPC, CVI
- Indirect mounting for series TRB, ITS, CCL-IS, MNI, CSL-RD, RPC, ICS-D2, ICM, KHZ, TRR

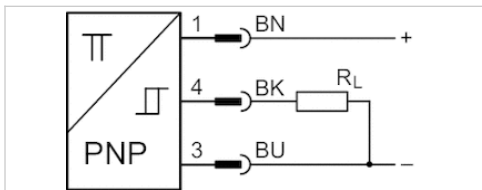

Certificates	ATEX CE declaration of conformity cULus RoHS
ATEX class G	II 3G Ex nA IIC T4 Gc X
ATEX class D	II 3D Ex tc IIIC T135°C Dc X
Ambient temperature min./max.	-20 ... 50 °C
Protection class	IP67
Switching point precision	±0,1 mT
Quiescent current (without load)	10 mA
Min./max. DC operating voltage	10 ... 30 V DC
Switching logic	NO (make contact)
LED status display	Yellow Yellow
Vibration resistance	10 - 55 Hz, 1 mm
Shock resistance	30 g / 11 ms
Cable length L	0.3 m

## Technical data

Part No.	for	Type of contact	Cable length L
R412022864	PRA, PRE, CCI, KPZ, SSI, GPC, CVI	electronic PNP	0.3 m

Part No.	Voltage drop U at I <sub>max</sub>	DC switching current, max.
R412022864	≤ 2,5 V	0.1 A

Part No.	Max. switching frequency
R412022864	1000 Hz

Part No.	Version
R412022864	short circuit resistant Protected against polarity reversal

## Technical information

### Material

Housing	Polyamide
Cable sheath	Polyurethane
Locking screw	Stainless steel

## Dimensions

### Dimensions

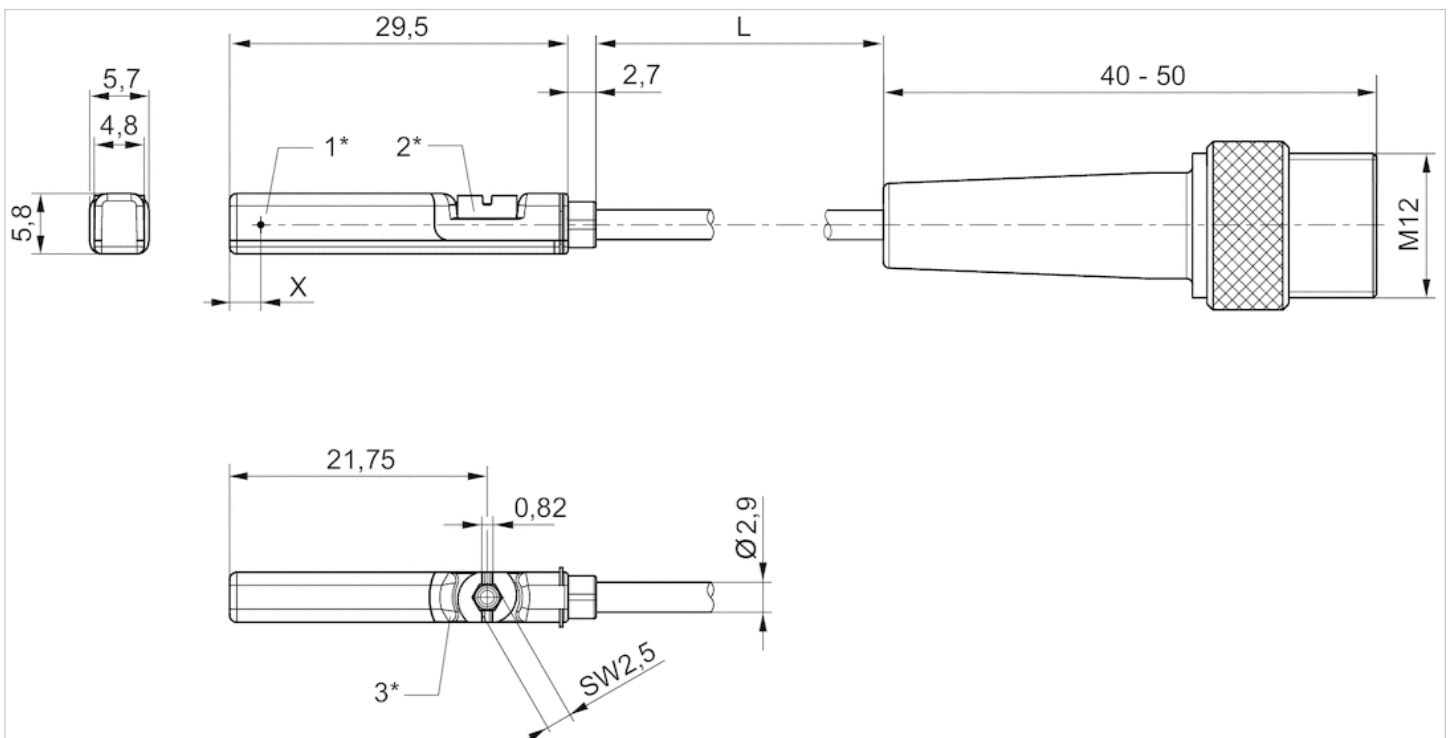

1\* = switching point 2\* = locking screw 3\* = LED window, transparent

L = cable length

X = PNP: 11,6 mm, reed: 8,3 mm

## Pin assignments

### Pin assignments

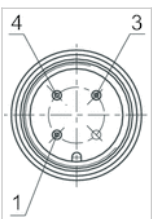

Pin	1	3	4
Allocation	(+)	(-)	(OUT)







# Sensor, Series ST6

- 6 mm T-slot
- with cable
- Plug, M12, 2-pin, with knurled screw Plug, M12, 4-pin, with knurled screw
- UL certification
- Reed electronic PNP
- Direct mounting for series PRA, PRE, CCI, KPZ, SSI, GPC, CVI
- Indirect mounting for series TRB, ITS, CCL-IS, MNI, CSL-RD, RPC, ICS-D2, ICM, KHZ, TRR



Certificates	CE declaration of conformity cULus RoHS
Ambient temperature min./max.	-30 ... 80 °C
Protection class	See table below
Switching point precision	±0,1 mT
Nominal current, actuated state	30 mA
Quiescent current (without load)	8 mA
Min./max. DC operating voltage	10 ... 30 V DC
Min./max. AC operating voltage	See table below
Hysteresis	≥ 0,2 mT
Switching logic	NO (make contact)
LED status display	Yellow
Vibration resistance	10 - 55 Hz, 1 mm
Shock resistance	30 g / 11 ms
Cable length L	0.3 0.1 3 5 m

## Technical data

Part No.		for	Type of contact
R412027171		PRA, PRE, CCI, KPZ, SSI, GPC, CVI	Reed
R412022876		PRA, PRE, CCI, KPZ, SSI, GPC, CVI	Reed
R412022879		PRA, PRE, CCI, KPZ, SSI, GPC, CVI	electronic PNP
R412022863		PRA, PRE, CCI, KPZ, SSI, GPC, CVI	electronic PNP
R412022877		PRA, PRE, CCI, KPZ, SSI, GPC, CVI	electronic PNP
R412022878		PRA, PRE, CCI, KPZ, SSI, GPC, CVI	electronic PNP

Part No.	Cable length L	Min./max. AC operating voltage	Voltage drop U at I <sub>max</sub>
R412027171	0.3 m	10 ... 30 V AC	≤ 3,5 V
R412022876	0.3 m	10 ... 30 V AC	≤ 0,1 V
R412022879	0.1 m	-	≤ 2,5 V
R412022863	0.3 m	-	≤ 2,5 V
R412022877	3 m	-	≤ 2,5 V
R412022878	5 m	-	≤ 2,5 V

Part No.	DC switching current, max.	AC switching current, max.
R412027171	0.13 A	0.13 A
R412022876	0.3 A	0.5 A

Part No.	DC switching current, max.	AC switching current, max.
R412022879	0.13 A	-
R412022863	0.13 A	-
R412022877	0.13 A	-
R412022878	0.13 A	-

Part No.	Switching capacity	Max. switching frequency
R412027171	Reed, 2-pin: max. 10 W	400 Hz
R412022876	Reed, 3-pin: max. 6 W	400 Hz
R412022879	-	1000 Hz
R412022863	-	1000 Hz
R412022877	-	1000 Hz
R412022878	-	1000 Hz

Part No.	Operating current, not switched	Operating current, switched	Protection class
R412027171	-	-	IP65, IP67
R412022876	-	-	IP65, IP67
R412022879	8 mA	30 mA	IP65, IP67
R412022863	8 mA	30 mA	IP65, IP67, IP69K
R412022877	8 mA	30 mA	IP65, IP67
R412022878	8 mA	30 mA	IP65, IP67

Part No.	Version	
R412027171	Protected against polarity reversal	1)
R412022876	Protected against polarity reversal	1)
R412022879	short circuit resistant Protected against polarity reversal	-
R412022863	short circuit resistant Protected against polarity reversal	-
R412022877	short circuit resistant Protected against polarity reversal	-
R412022878	short circuit resistant Protected against polarity reversal	-

1) The product of operating voltage and continuous current must not exceed the maximum switching capacity.

## Technical information

Material	
Housing	Polyamide
Cable sheath	Polyurethane
Locking screw	Stainless steel

## Dimensions

### Dimensions

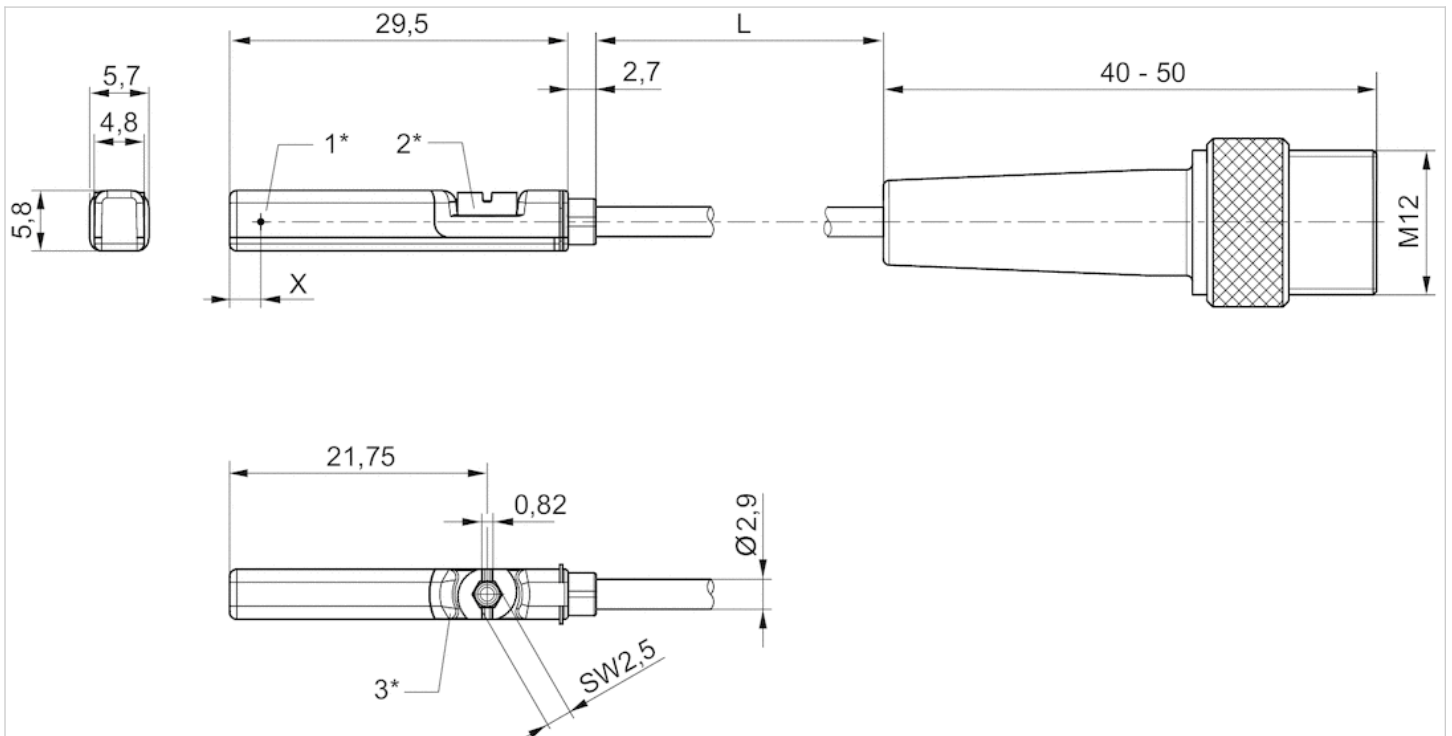

1\* = switching point 2\* = locking screw 3\* = LED window, transparent  
 L = cable length  
 X = PNP: 11,6 mm, reed: 8,3 mm

# Sensor, Series ST6

- 6 mm T-slot
- with cable
- Plug, M8, 3-pin, with knurled screw
- ATEX
- UL certification, ATEX
- electronic PNP
- Direct mounting for series PRA, PRE, CCI, KPZ, SSI, GPC, CVI
- Indirect mounting for series TRB, ITS, CCL-IS, MNI, CSL-RD, RPC, ICS-D2, ICM, KHZ, TRR

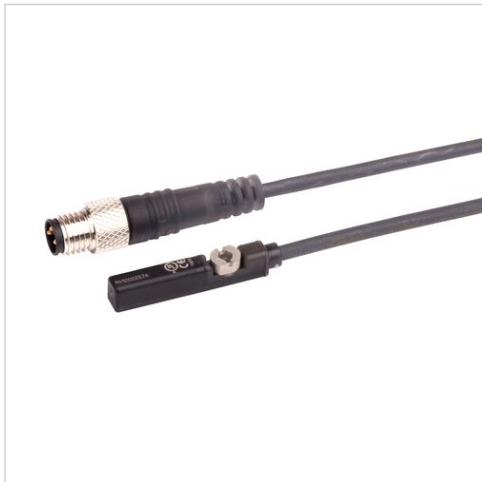

Certificates	ATEX CE declaration of conformity cULus RoHS
ATEX class G	II 3G Ex nA IIC T4 Gc X
ATEX class D	II 3D Ex tc IIIC T135°C Dc X
Ambient temperature min./max.	-20 ... 50 °C
Protection class	IP65, IP67
Switching point precision	±0,1 mT
Quiescent current (without load)	10 mA
Min./max. DC operating voltage	10 ... 30 V DC
Switching logic	NO (make contact)
LED status display	Yellow Yellow
Vibration resistance	10 - 55 Hz, 1 mm
Shock resistance	30 g / 11 ms
Cable length L	0.3 m

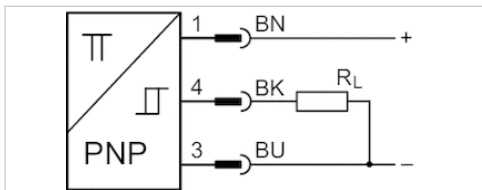

## Technical data

Part No.	for	Type of contact	Cable length L
R412022860	PRA, PRE, CCI, KPZ, SSI, GPC, CVI	electronic PNP	0.3 m

Part No.	Voltage drop U at I <sub>max</sub>	DC switching current, max.
R412022860	≤ 2,5 V	0.1 A

Part No.	Max. switching frequency
R412022860	1000 Hz

Part No.	Version
R412022860	short circuit resistant Protected against polarity reversal

## Technical information

### Material

Housing	Polyamide
Cable sheath	Polyurethane
Locking screw	Stainless steel

## Dimensions

### Dimensions

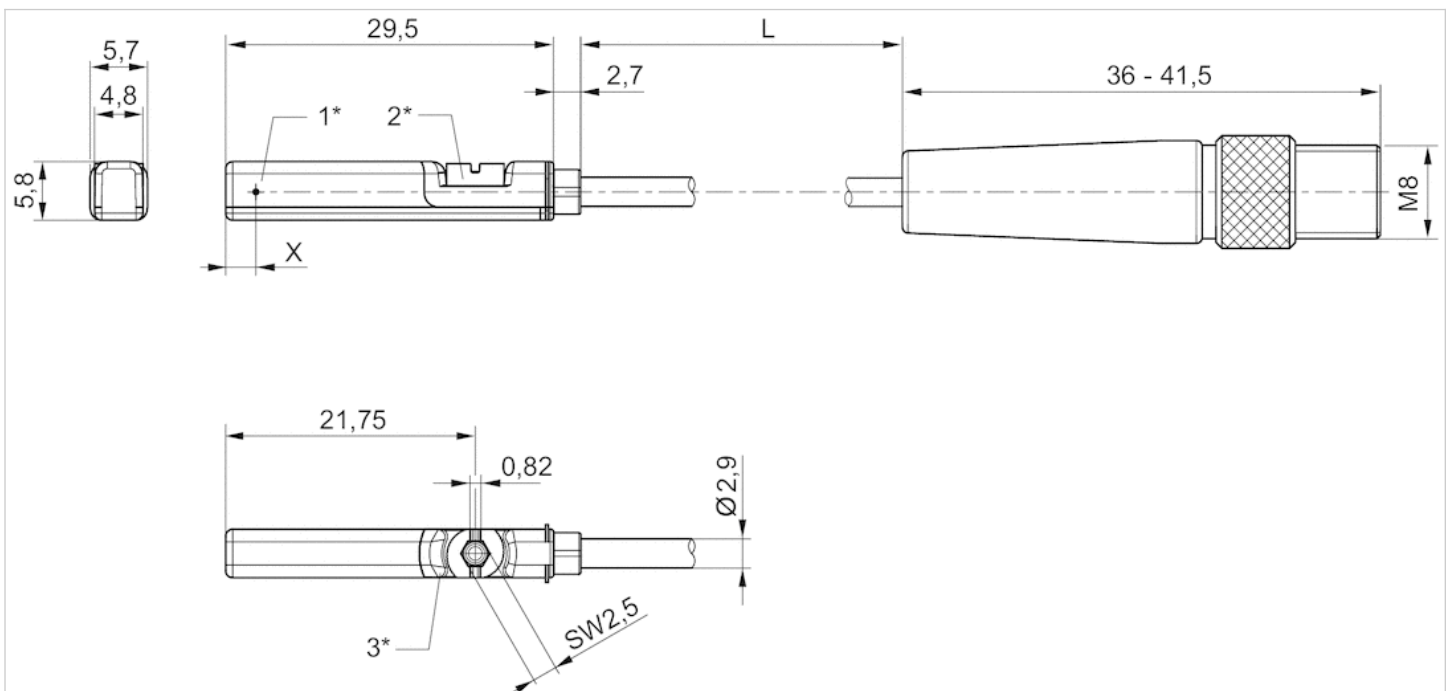

1\* = switching point 2\* = locking screw 3\* = LED window, transparent  
 L = cable length  
 X = electronic: 11,6 mm, Reed: 8,3 mm

## Pin assignments

### Pin assignments

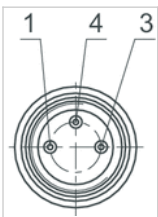

Pin	1	3	4
Allocation	(+)	(-)	(OUT)









# Sensor, Series ST6

- 6 mm T-slot
- with cable
- Plug, M8, 3-pin, with knurled screw
- UL certification
- Reed electronic PNP electronic NPN
- Direct mounting for series PRA, PRE, CCI, KPZ, SSI, GPC, CVI
- Indirect mounting for series TRB, ITS, CCL-IS, MNI, CSL-RD, RPC, ICS-D2, ICM, KHZ, TRR



Certificates	CE declaration of conformity cULus RoHS
Ambient temperature min./max.	-30 ... 80 °C
Protection class	IP65, IP67
Switching point precision	±0,1 mT
Nominal current, actuated state	30 mA
Quiescent current (without load)	8 mA
Min./max. DC operating voltage	10 ... 30 V DC
Min./max. AC operating voltage	See table below
Hysteresis	≥ 0,2 mT
Switching logic	NO (make contact)
Switching capacity	Reed, 3-pin: max. 6 W
LED status display	Yellow
Vibration resistance	10 - 55 Hz, 1 mm
Shock resistance	30 g / 11 ms
Cable length L	0.3 0.5 m

## Technical data

Part No.		for	Type of contact
R412022873		PRA, PRE, CCI, KPZ, SSI, GPC, CVI	Reed
R412022875		PRA, PRE, CCI, KPZ, SSI, GPC, CVI	Reed
R412022874		PRA, PRE, CCI, KPZ, SSI, GPC, CVI	Reed
R412022859		PRA, PRE, CCI, KPZ, SSI, GPC, CVI	electronic PNP
R412022862		PRA, PRE, CCI, KPZ, SSI, GPC, CVI	electronic PNP
R412022861		PRA, PRE, CCI, KPZ, SSI, GPC, CVI	electronic PNP
R412022852		PRA, PRE, CCI, KPZ, SSI, GPC, CVI	electronic NPN

Part No.	Cable sheath	Cable length L	Min./max. AC operating voltage
R412022873	Polyurethane	0.3 m	10 ... 30 V AC
R412022875	Polyvinyl chloride	0.3 m	10 ... 30 V AC
R412022874	Polyurethane	0.5 m	10 ... 30 V AC
R412022859	Polyurethane	0.3 m	-
R412022862	Polyvinyl chloride	0.3 m	-
R412022861	Polyurethane	0.5 m	-
R412022852	Polyurethane	0.3 m	-

Part No.	Voltage drop U at I <sub>max</sub>	DC switching current, max.
R412022873	I*Rs	0.3 A
R412022875	I*Rs	0.3 A
R412022874	I*Rs	0.3 A
R412022859	≤ 2,5 V	0.13 A
R412022862	≤ 2,5 V	0.13 A
R412022861	≤ 2,5 V	0.13 A
R412022852	≤ 2,5 V	0.13 A

Part No.	AC switching current, max.	Max. switching frequency
R412022873	0.5 A	400 Hz
R412022875	0.5 A	400 Hz
R412022874	0.5 A	400 Hz
R412022859	-	1000 Hz
R412022862	-	1000 Hz
R412022861	-	1000 Hz
R412022852	-	1000 Hz

Part No.	Operating current, not switched	Operating current, switched
R412022873	-	-
R412022875	-	-
R412022874	-	-
R412022859	8 mA	30 mA
R412022862	8 mA	30 mA
R412022861	8 mA	30 mA
R412022852	8 mA	30 mA

Part No.	Version
R412022873	Protected against polarity reversal
R412022875	Protected against polarity reversal
R412022874	Protected against polarity reversal
R412022859	short circuit resistant Protected against polarity reversal
R412022862	short circuit resistant Protected against polarity reversal
R412022861	short circuit resistant Protected against polarity reversal
R412022852	short circuit resistant Protected against polarity reversal

## Technical information

Material	
Housing	Polyamide
Cable sheath	Polyurethane Polyvinyl chloride
Locking screw	Stainless steel

## Dimensions

### Dimensions

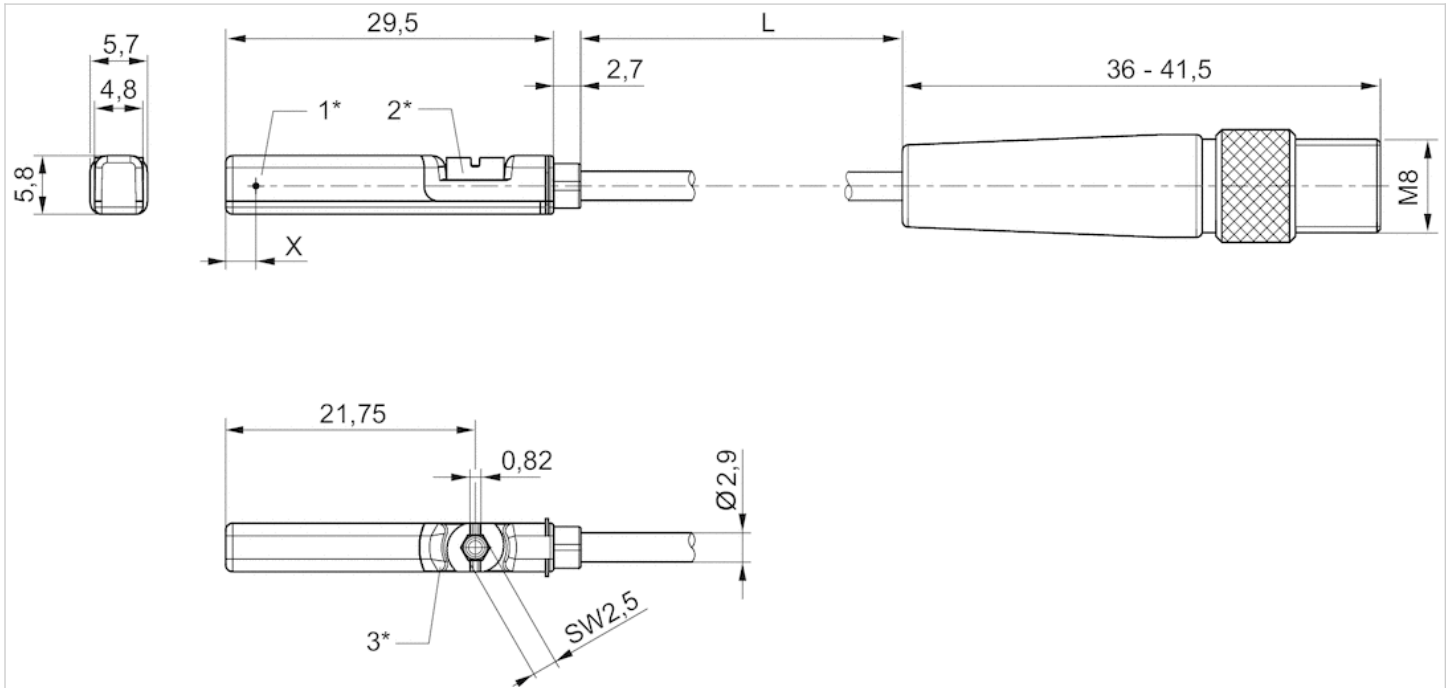

1\* = switching point 2\* = locking screw 3\* = LED window, transparent  
 L = cable length  
 X = electronic: 11,6 mm, Reed: 8,3 mm

## Pin assignments

### Pin assignments

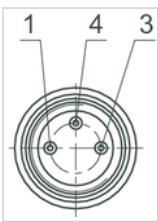

Pin	1	3	4
Allocation	(+)	(-)	(OUT)

# Sensor, Series ST6-HT

- 6 mm T-slot
- with cable
- open cable ends, 2-pin
- Heat resistant
- UL certification
- Reed
- Direct mounting for series PRA, PRE, CCI, KPZ
- Indirect mounting for series TRB, ITS, CCL-IS, MNI, CSL-RD, RPC



Certificates	CE declaration of conformity RoHS
Ambient temperature min./max.	-20 ... 120 °C
Protection class	IP65, IP67
Switching point precision	±0,1 mT
Min./max. DC operating voltage	0 ... 30 V DC
Min./max. AC operating voltage	0 ... 30 V AC
Switching logic	NO (make contact)
Switching capacity	Reed, 2-pin: max. 10 W
Vibration resistance	10 - 55 Hz, 1 mm
Shock resistance	30 g / 11 ms
Cable length L	3 10 m

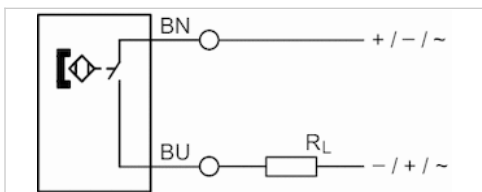

## Technical data

Part No.	for	Type of contact	Cable length L	Voltage drop U at I <sub>max</sub>
R412022865	PRA, PRE, CCI, KPZ	Reed	3 m	≤ 3,5 V
R412022867	PRA, PRE, CCI, KPZ	Reed	10 m	≤ 3,5 V

Part No.	DC switching current, max.	AC switching current, max.
R412022865	0.13 A	0.13 A
R412022867	0.13 A	0.13 A

Part No.	Max. switching frequency	Version
R412022865	400 Hz	Protected against polarity reversal
R412022867	400 Hz	Protected against polarity reversal

Part No.	Temperature resistance
R412022865	Heat resistant

Part No.	Temperature resistance
R412022867	Heat resistant

## Technical information

Material	
Housing	Polyamide
Cable sheath	Polyurethane
Locking screw	Stainless steel

## Dimensions

### Dimensions

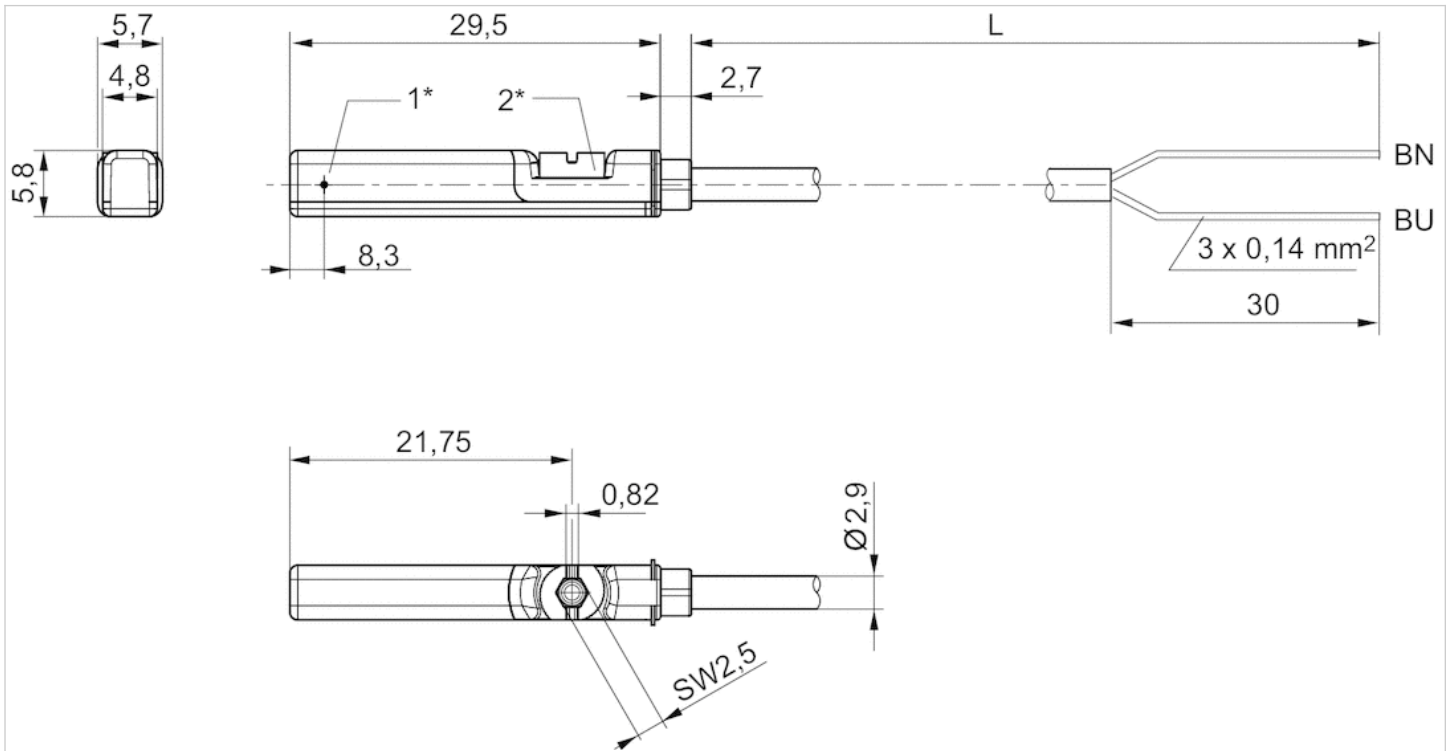

1\* = switching point 2\* = locking screw

L = cable length

BN=brown, BU=blue

# Sensor, Series ST6-LT

- 6 mm T-slot
- with cable
- open cable ends, 3-pin Plug, M8x1, 3-pin, with knurled screw Plug, M12x1, 3-pin, with knurled screw
- -40 °C cold-resistant
- UL certification
- electronic PNP
- Direct mounting for series PRA
- Indirect mounting for series TRB, ITS



Certificates	CE declaration of conformity cULus RoHS
Ambient temperature min./max.	-40 ... 80 °C
Protection class	IP65, IP67, IP68
Switching point precision	±0,1 mT
Quiescent current (without load)	10 mA
Min./max. DC operating voltage	10 ... 30 V DC
Hysteresis	≥ 0,2 mT
Switching logic	NO (make contact)
LED status display	Yellow
Vibration resistance	10 - 55 Hz, 1 mm
Shock resistance	30 g / 11 ms
Cable length L	5 0.3 m

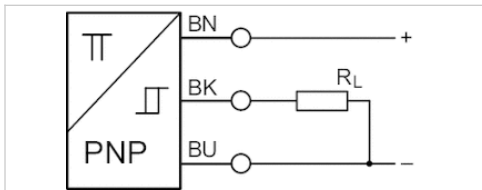

## Technical data

Part No.	for	Type of contact	Cable length L	Voltage drop U at I <sub>max</sub>
R412024011	PRA	electronic PNP	5 m	≤ 2,5 V
R412024669	PRA	electronic PNP	0.3 m	≤ 2,5 V
R412024670	PRA	electronic PNP	0.3 m	≤ 2,5 V

Part No.	DC switching current, max.	Max. switching frequency	Material Housing
R412024011	0.2 A	1000 Hz	Polyurethane
R412024669	0.2 A	1000 Hz	Polyamide
R412024670	0.2 A	1000 Hz	Polyamide

Part No.	Version	Temperature resistance	Fig.	
R412024011	short circuit resistant	-40 °C cold-resistant	Fig. 1	1)
R412024669	short circuit resistant	-40 °C cold-resistant	Fig. 2	2)
R412024670	short circuit resistant	-40 °C cold-resistant	Fig. 3	3)

- 1) open cable ends, 3-pin
- 2) Plug M8x1, 3-pin, with knurled screw
- 3) plug M12, 3-pin, with knurled screw

## Technical information

Cables must be firmly installed at temperatures of -40 °C ... -20 °C.

## Technical information

Material	
Housing	Polyurethane Polyamide
Cable sheath	Polyurethane
Locking screw	Stainless steel

## Dimensions

Fig. 1

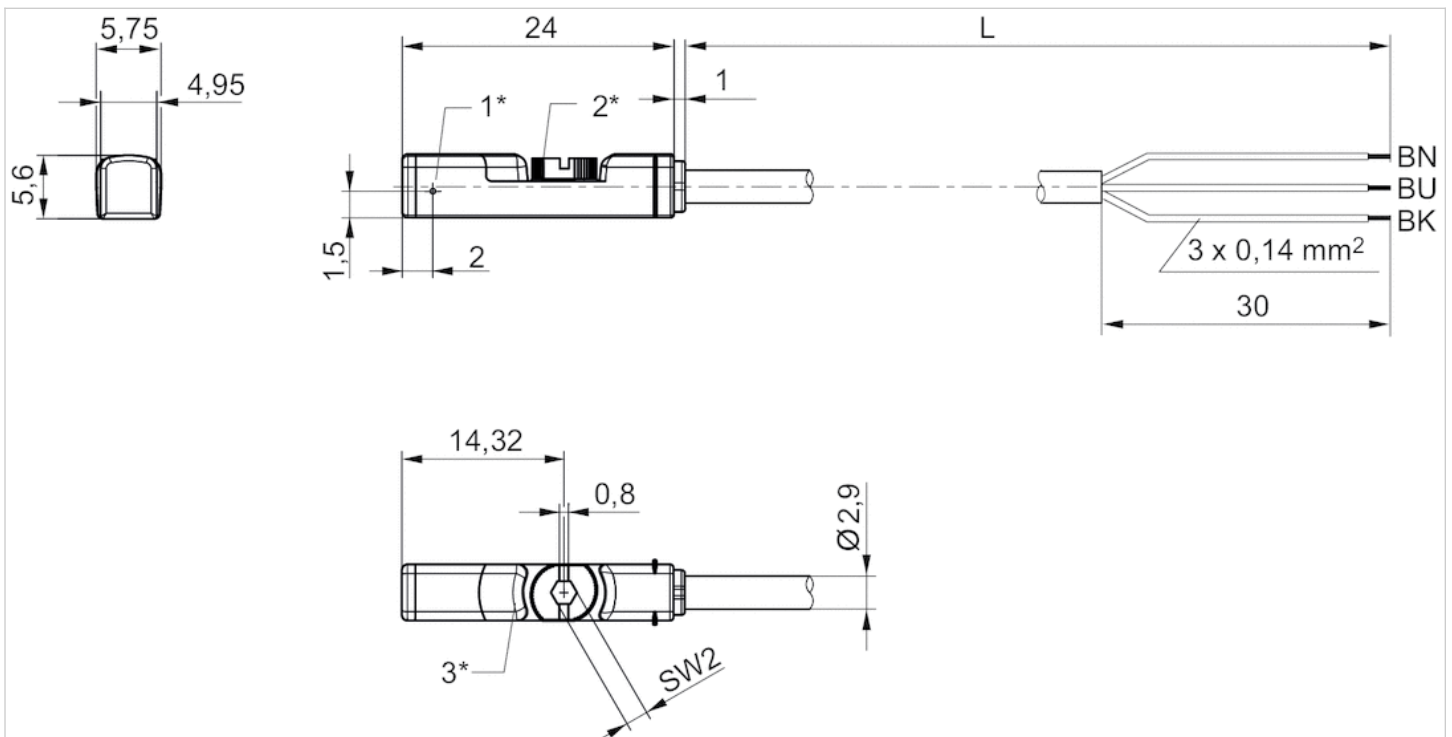

1\* = switching point 2\* = locking screw 3\* = LED window, transparent  
 L = cable length  
 BN = brown, BK = black, BU = blue

Fig. 2

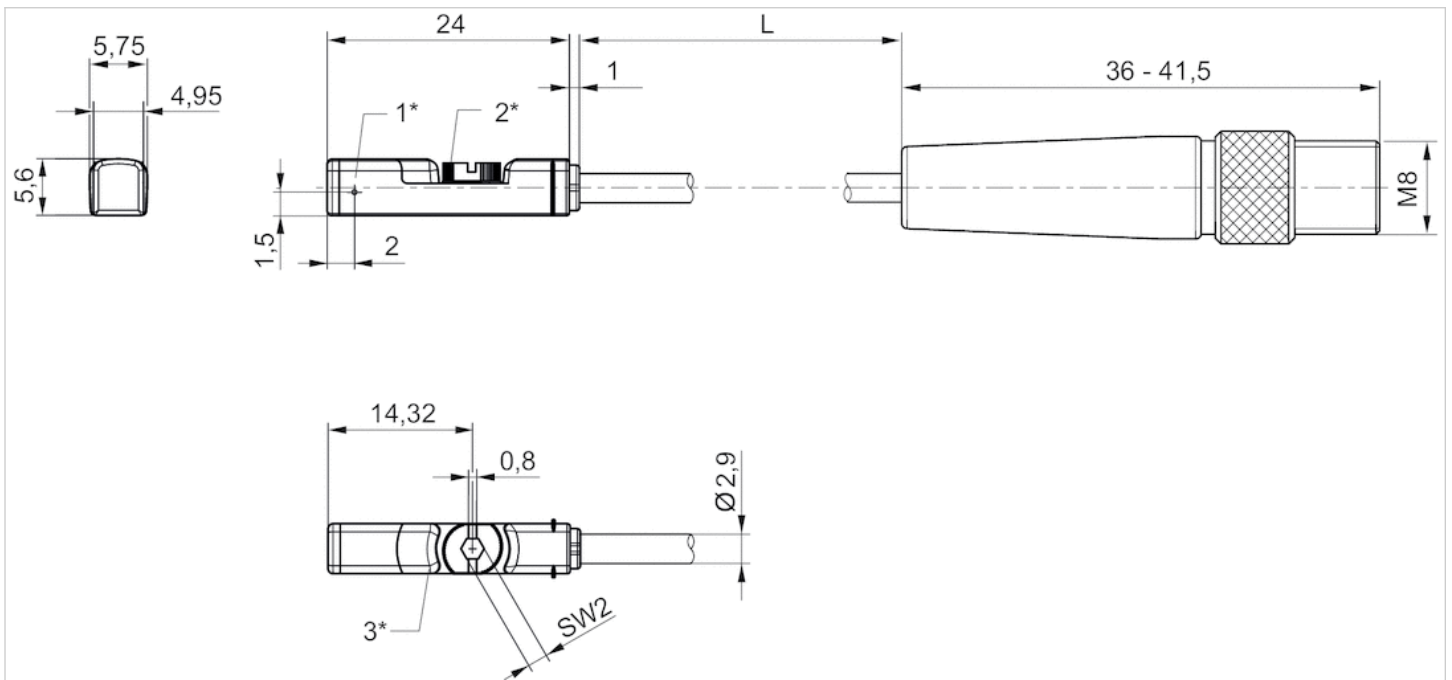

1\* = switching point 2\* = locking screw 3\* = LED window, transparent  
L = cable length

Fig. 3

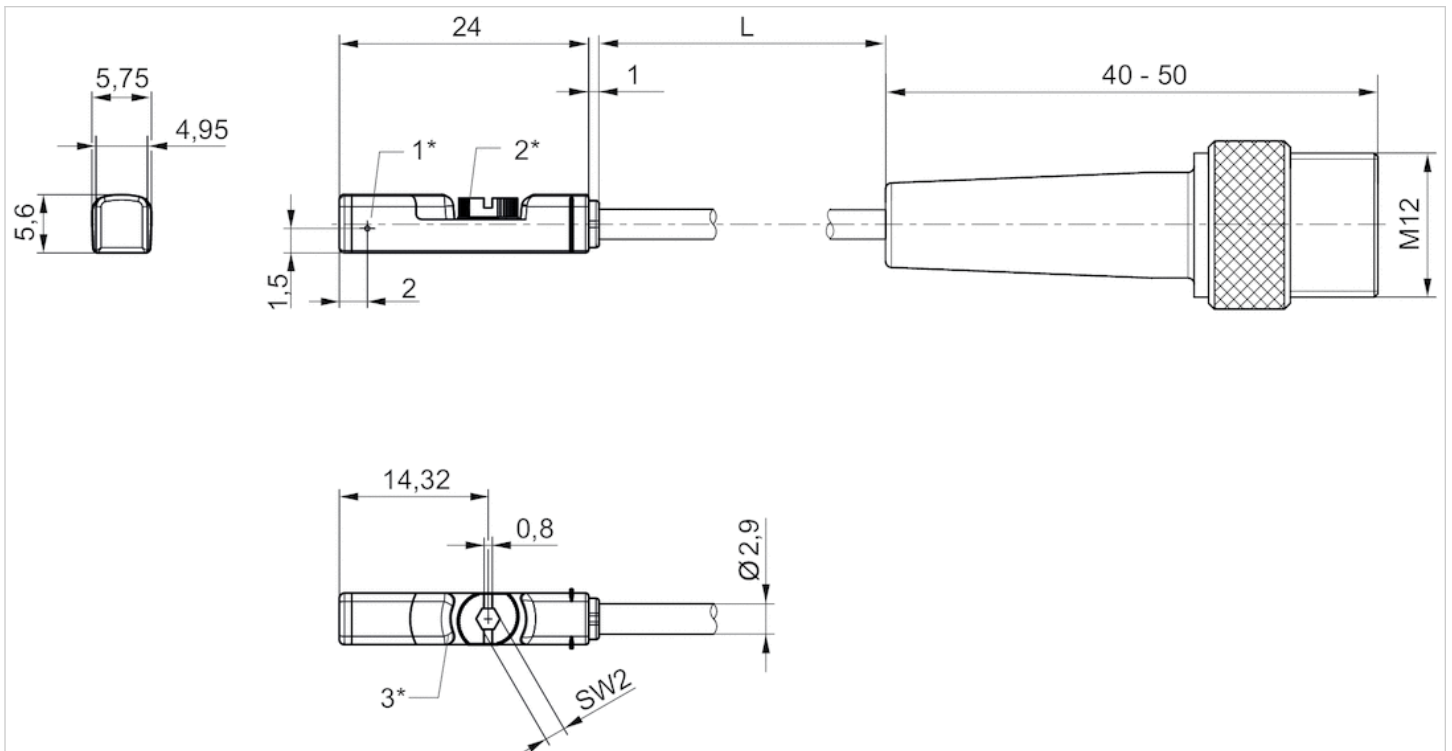

1\* = switching point 2\* = locking screw 3\* = LED window, transparent  
L = cable length



## Sensors, Series SM6-AL

- with cable
- Plug, M8x1, 4-pin
- with distance measuring sensor, measurement range 107 - 1007 mm
- IO-Link
- Analog
- Indirect mounting for series PRA, ITS, RTC, CVI

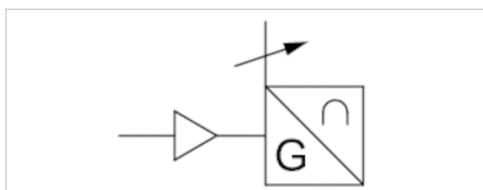

Certificates	cULus
Ambient temperature min./max.	-20 ... 70 °C
Protection class	IP65, IP67
Output signal	0 - 10 V DC, 4 - 20 mA
Quiescent current (without load)	35 mA
Current signal	4 ... 20 mA
Maximum load (analog current output)	500 Ω
Residual ripple	≤ 10 %
sampling interval	1,15 ms
Resolution max. measuring range	typ. 0,03 % FSR
Repetitive precision max. measuring range	typ. 0,06 % FSR
Linearity deviation	0,5 mm
Sampling speed Partial stroke	1,5 m/s
Sampling speed Full stroke	3 m/s
Display	2 LED
Vibration resistance	10 - 55 Hz, 1 mm
Shock resistance	30 g / 11 ms
Cable length L	0.3 m

### Technical data

Part No.	Type of contact	Cable length L	max. measuring range	Overall length Sensor A
R412010880	Analog	0.3 m	107 mm	109 mm
R412010881	Analog	0.3 m	143 mm	145 mm
R412010882	Analog	0.3 m	179 mm	181 mm
R412010883	Analog	0.3 m	215 mm	217 mm
R412010884	Analog	0.3 m	251 mm	253 mm
R412010885	Analog	0.3 m	287 mm	289 mm
R412010886	Analog	0.3 m	323 mm	325 mm
R412010887	Analog	0.3 m	359 mm	361 mm
R412010888	Analog	0.3 m	395 mm	397 mm
R412010889	Analog	0.3 m	431 mm	433 mm
R412010890	Analog	0.3 m	467 mm	469 mm
R412010891	Analog	0.3 m	503 mm	505 mm
R412010892	Analog	0.3 m	539 mm	541 mm
R412010893	Analog	0.3 m	575 mm	577 mm
R412010894	Analog	0.3 m	611 mm	613 mm
R412010895	Analog	0.3 m	647 mm	649 mm
R412010896	Analog	0.3 m	683 mm	685 mm

Part No.	Type of contact	Cable length L	max. measuring range	Overall length Sensor A
R412010897	Analog	0.3 m	719 mm	721 mm
R412010898	Analog	0.3 m	755 mm	757 mm
R412010899	Analog	0.3 m	791 mm	793 mm
R412010900	Analog	0.3 m	827 mm	829 mm
R412010901	Analog	0.3 m	863 mm	865 mm
R412010902	Analog	0.3 m	899 mm	901 mm
R412010903	Analog	0.3 m	935 mm	937 mm
R412010904	Analog	0.3 m	971 mm	973 mm
R412010905	Analog	0.3 m	1007 mm	1009 mm

Part No.	Incl. number of sensor clamp pairs	Current signal
R412010880	2 piece	4 ... 20 mA
R412010881	2 piece	4 ... 20 mA
R412010882	2 piece	4 ... 20 mA
R412010883	2 piece	4 ... 20 mA
R412010884	2 piece	4 ... 20 mA
R412010885	3 piece	4 ... 20 mA
R412010886	3 piece	4 ... 20 mA
R412010887	3 piece	4 ... 20 mA
R412010888	3 piece	4 ... 20 mA
R412010889	3 piece	4 ... 20 mA
R412010890	4 piece	4 ... 20 mA
R412010891	4 piece	4 ... 20 mA
R412010892	4 piece	4 ... 20 mA
R412010893	4 piece	4 ... 20 mA
R412010894	4 piece	4 ... 20 mA
R412010895	4 piece	4 ... 20 mA
R412010896	5 piece	4 ... 20 mA
R412010897	5 piece	4 ... 20 mA
R412010898	5 piece	4 ... 20 mA
R412010899	5 piece	4 ... 20 mA
R412010900	6 piece	4 ... 20 mA
R412010901	6 piece	4 ... 20 mA
R412010902	6 piece	4 ... 20 mA
R412010903	6 piece	4 ... 20 mA
R412010904	6 piece	4 ... 20 mA
R412010905	6 piece	4 ... 20 mA

Part No.	Version
R412010880	short circuit resistant Protected against polarity reversal Overload protection
R412010881	short circuit resistant Protected against polarity reversal Overload protection
R412010882	short circuit resistant Protected against polarity reversal Overload protection
R412010883	short circuit resistant Protected against polarity reversal Overload protection
R412010884	short circuit resistant Protected against polarity reversal Overload protection
R412010885	short circuit resistant Protected against polarity reversal Overload protection

Part No.	Version
R412010886	short circuit resistant Protected against polarity reversal Overload protection
R412010887	short circuit resistant Protected against polarity reversal Overload protection
R412010888	short circuit resistant Protected against polarity reversal Overload protection
R412010889	short circuit resistant Protected against polarity reversal Overload protection
R412010890	short circuit resistant Protected against polarity reversal Overload protection
R412010891	short circuit resistant Protected against polarity reversal Overload protection
R412010892	short circuit resistant Protected against polarity reversal Overload protection
R412010893	short circuit resistant Protected against polarity reversal Overload protection
R412010894	short circuit resistant Protected against polarity reversal Overload protection
R412010895	short circuit resistant Protected against polarity reversal Overload protection
R412010896	short circuit resistant Protected against polarity reversal Overload protection
R412010897	short circuit resistant Protected against polarity reversal Overload protection
R412010898	short circuit resistant Protected against polarity reversal Overload protection
R412010899	short circuit resistant Protected against polarity reversal Overload protection
R412010900	short circuit resistant Protected against polarity reversal Overload protection
R412010901	short circuit resistant Protected against polarity reversal Overload protection
R412010902	short circuit resistant Protected against polarity reversal Overload protection
R412010903	short circuit resistant Protected against polarity reversal Overload protection
R412010904	short circuit resistant Protected against polarity reversal Overload protection
R412010905	short circuit resistant Protected against polarity reversal Overload protection

## Technical information

Holders for cylinder series PRA are included in the scope of delivery. For cylinder series ITS, please order the appropriate holders separately.

FSR: Full Scale Range, max. measurement range

The IO-Link device description (IODD) for the SM6-AL distance measuring sensor is available for download in the Media Centre.

## Technical information

Material	
Housing	Aluminum
Cable sheath	Polyurethane
End caps	Polyamide

## Dimensions

### Dimensions

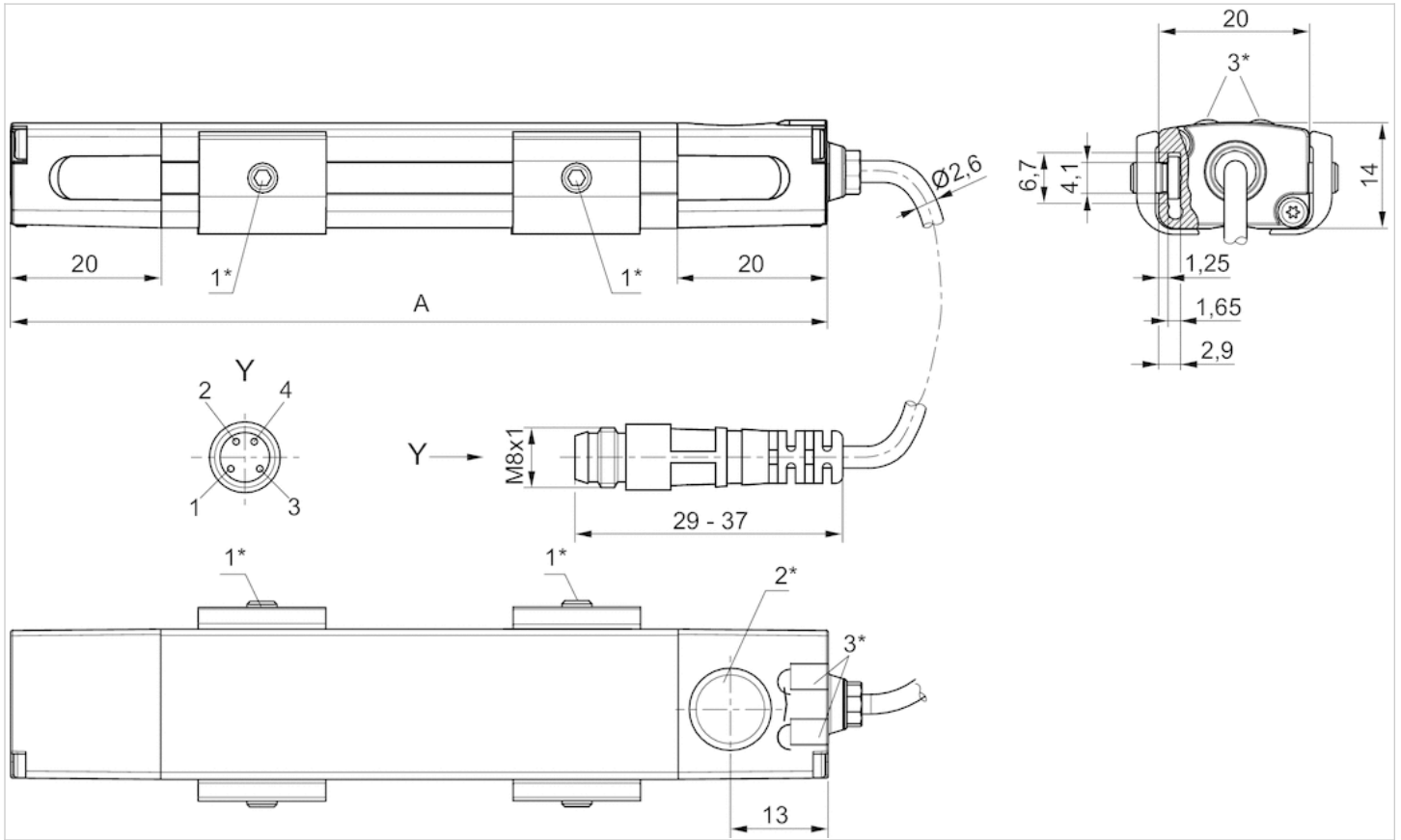

1\* = threaded pin M3x11 2\* = teach area 3\* = LED

A = sensor length

Pin assignment: 1 = (+), 2 = (OUT 1) 3 = (GND), 4 = (OUT 2/IO-Link), EN 60947-5-7

LED 1: yellow = measuring operation, red = error

LED 2: green = voltage signal, blue = current signal





















## Sensor, Series SN2

- with cable
- without wire end ferrule, tin-plated, 2-pin without wire end ferrule, tin-plated, 3-pin
- Heat resistant
- Reed electronic PNP
- Indirect mounting for series TRB, PRA, ITS, MNI, CSL-RD, ICM, RPC, TRR, FLT, CVI



Ambient temperature min./max.	See table below
Protection class	IP67
Switching point precision	±0,1 mT
Nominal current, actuated state	15 mA
Quiescent current (without load)	10 mA
Min./max. DC operating voltage	See table below
Min./max. AC operating voltage	See table below
LED status display	See table below
Cable length L	3 5 7 10 11 20 m

## Technical data

Part No.		Type of contact	Cable sheath	Cable length L
0830100315		Reed	Polyvinyl chloride	3 m
0830100365		Reed	Polyvinyl chloride	3 m
0830100368		Reed	Polyvinyl chloride	3 m
0830100370		Reed	Polyurethane	3 m
0830100316		Reed	-	3 m
0830100373		Reed	-	3 m
0830100367		Reed	Polyurethane	3 m
0830100317		Reed	Thermoplastic elastomer	3 m
0830100366		Reed	Polyvinyl chloride	5 m
0830100369		Reed	Polyvinyl chloride	5 m
0830100327		Reed	Polyvinyl chloride	7 m
0830100325		Reed	Polyvinyl chloride	10 m
0830100326		Reed	Thermoplastic elastomer	11 m
R412004848		Reed	Polyvinyl chloride	20 m
0830100371		Reed	Polyvinyl chloride	3 m
0830100372		Reed	Polyvinyl chloride	5 m
0830100375		electronic PNP	Polyvinyl chloride	3 m
0830100378		electronic PNP	Thermoplastic elastomer	3 m
0830100377		electronic PNP	Polyurethane	3 m
0830100376		electronic PNP	Polyvinyl chloride	5 m

Part No.	Min./max. DC operating voltage	Min./max. AC operating voltage
0830100315	0 ... 60 V DC	0 ... 240 V AC
0830100365	12 ... 60 V DC	12 ... 240 V AC
0830100368	12 ... 60 V DC	12 ... 240 V AC
0830100370	12 ... 60 V DC	12 ... 240 V AC
0830100316	0 ... 60 V DC	0 ... 240 V AC
0830100373	0 ... 60 V DC	0 ... 240 V AC
0830100367	12 ... 60 V DC	12 ... 240 V AC
0830100317	12 ... 60 V DC	12 ... 240 V AC
0830100366	12 ... 60 V DC	12 ... 240 V AC
0830100369	12 ... 60 V DC	12 ... 240 V AC
0830100327	12 ... 60 V DC	12 ... 240 V AC
0830100325	12 ... 60 V DC	12 ... 240 V AC
0830100326	12 ... 60 V DC	12 ... 240 V AC
R412004848	12 ... 60 V DC	12 ... 240 V AC
0830100371	12 ... 42 V DC	12 ... 42 V AC
0830100372	12 ... 42 V DC	12 ... 42 V AC
0830100375	10 ... 30 V DC	10 ... 30 V AC
0830100378	10 ... 30 V DC	-
0830100377	10 ... 30 V DC	10 ... 30 V AC
0830100376	10 ... 30 V DC	10 ... 30 V AC

Part No.	Voltage drop U at I <sub>max</sub>	DC switching current, max.
0830100315	$R_s \cdot I_{max}$	0.13 A
0830100365	$2,1 \text{ V} + I \cdot R_s$	0.13 A
0830100368	$2,1 \text{ V} + I \cdot R_s$	0.3 A
0830100370	$2,1 \text{ V} + I \cdot R_s$	0.3 A
0830100316	$R_s \cdot I_{max}$	0.13 A
0830100373	$R_s \cdot I_{max}$	0.13 A
0830100367	$2,1 \text{ V} + I \cdot R_s$	0.13 A
0830100317	$2,1 \text{ V} + I \cdot R_s$	0.12 A
0830100366	$2,1 \text{ V} + I \cdot R_s$	0.13 A
0830100369	$2,1 \text{ V} + I \cdot R_s$	0.3 A
0830100327	$2,1 \text{ V} + I \cdot R_s$	0.3 A
0830100325	$2,1 \text{ V} + I \cdot R_s$	0.13 A
0830100326	$2,1 \text{ V} + I \cdot R_s$	0.12 A
R412004848	$2,1 \text{ V} + I \cdot R_s$	0.13 A
0830100371	$I \cdot R_s$	0.13 A
0830100372	$I \cdot R_s$	0.13 A
0830100375	$\leq 2,0 \text{ V}$	0.13 A
0830100378	$2,1 \text{ V} + I \cdot R_s$	0.12 A
0830100377	$\leq 2,0 \text{ V}$	0.13 A
0830100376	$\leq 2,0 \text{ V}$	0.13 A

Part No.	AC switching current, max.	Ambient temperature min./max.	Switching capacity
0830100315	0.13 A	-20 ... 80 °C	10 W / 10 VA
0830100365	0.13 A	-20 ... 80 °C	10 W / 10 VA
0830100368	0.5 A	-20 ... 80 °C	10 W / 10 VA
0830100370	0.5 A	-20 ... 80 °C	10 W / 10 VA
0830100316	-	-20 ... 80 °C	10 W / 10 VA
0830100373	-	-20 ... 80 °C	10 W / 10 VA
0830100367	0.13 A	-20 ... 80 °C	10 W / 10 VA
0830100317	0.12 A	-20 ... 120 °C	10 W / 10 VA
0830100366	0.13 A	-20 ... 80 °C	10 W / 10 VA
0830100369	0.5 A	-20 ... 80 °C	10 W / 10 VA
0830100327	0.5 A	-20 ... 80 °C	10 W / 10 VA
0830100325	0.13 A	-20 ... 80 °C	10 W / 10 VA
0830100326	0.12 A	-20 ... 120 °C	10 W / 10 VA
R412004848	0.13 A	-20 ... 80 °C	10 W / 10 VA
0830100371	0.13 A	-20 ... 80 °C	5,5 W / 5,5 VA
0830100372	0.13 A	-20 ... 80 °C	5,5 W / 5,5 VA
0830100375	-	-10 ... 70 °C	-
0830100378	-	-20 ... 120 °C	10 W / 10 VA
0830100377	-	-10 ... 70 °C	-
0830100376	-	-10 ... 70 °C	-

Part No.	Protective resistor for reed	Vibration resistance	Shock resistance
0830100315	27 Ω	-	-

Part No.	Protective resistor for reed	Vibration resistance	Shock resistance
0830100365	27 Ω	30 g (50 - 1000 Hz)	50 g / 11 ms
0830100368	1,3 Ω	30 g (50 - 1000 Hz)	50 g / 11 ms
0830100370	1,3 Ω	30 g (50 - 1000 Hz)	50 g / 11 ms
0830100316	1,3 Ω	-	-
0830100373	100 Ω	-	-
0830100367	27 Ω	30 g (50 - 1000 Hz)	50 g / 11 ms
0830100317	27 Ω	30 g (50 - 1000 Hz)	100 g / 11 ms
0830100366	27 Ω	30 g (50 - 1000 Hz)	50 g / 11 ms
0830100369	1,3 Ω	30 g (50 - 1000 Hz)	50 g / 11 ms
0830100327	1,3 Ω	30 g (50 - 1000 Hz)	50 g / 11 ms
0830100325	27 Ω	30 g (50 - 1000 Hz)	50 g / 11 ms
0830100326	27 Ω	30 g (50 - 1000 Hz)	100 g / 11 ms
R412004848	27 Ω	30 g (50 - 1000 Hz)	50 g / 11 ms
0830100371	27 Ω	30 g (50 - 1000 Hz)	100 g / 11 ms
0830100372	27 Ω	30 g (50 - 1000 Hz)	100 g / 11 ms
0830100375	-	-	-
0830100378	27 Ω	30 g (50 - 1000 Hz)	100 g / 11 ms
0830100377	-	-	-
0830100376	-	-	-

Part No.	Max. switching frequency	Operating current, not switched
0830100315	300 Hz	-
0830100365	-	-
0830100368	-	-
0830100370	-	-
0830100316	300 Hz	-
0830100373	300 Hz	-
0830100367	-	-
0830100317	-	-
0830100366	-	-
0830100369	-	-
0830100327	-	-
0830100325	-	-
0830100326	-	-
R412004848	-	-
0830100371	-	-
0830100372	-	-
0830100375	2000 Hz	10 mA
0830100378	-	-
0830100377	2000 Hz	10 mA
0830100376	2000 Hz	10 mA

Part No.	Operating current, switched	Material Housing	LED status display
0830100315	-	Polyamide	-
0830100365	-	Polyamide	Yellow



Part No.	Operating current, switched	Material Housing	LED status display
0830100368	-	Polyamide	Yellow
0830100370	-	Polyamide	Yellow
0830100316	-	Polyamide	-
0830100373	-	Polyamide	-
0830100367	-	Polyamide	Yellow
0830100317	-	Polyamide	-
0830100366	-	Polyamide	Yellow
0830100369	-	Polyamide	Yellow
0830100327	-	Polyamide	Yellow
0830100325	-	Polyamide	Yellow
0830100326	-	Polyamide	-
R412004848	-	epoxy resin	Yellow
0830100371	-	Polyamide	Yellow
0830100372	-	Polyamide	Yellow
0830100375	15 mA	Polyamide	Yellow
0830100378	-	Polyamide	-
0830100377	15 mA	Polyamide	Yellow
0830100376	15 mA	Polyamide	Yellow

Part No.	Version	
0830100315	Protected against polarity reversal	1)
0830100365	Protected against polarity reversal	1)
0830100368	Protected against polarity reversal	1)
0830100370	Protected against polarity reversal	1)
0830100316	Protected against polarity reversal	1)
0830100373	Protected against polarity reversal	1)
0830100367	Protected against polarity reversal	1)
0830100317	Protected against polarity reversal	1)
0830100366	Protected against polarity reversal	1)
0830100369	Protected against polarity reversal	1)
0830100327	Protected against polarity reversal	1)
0830100325	Protected against polarity reversal	1)
0830100326	Protected against polarity reversal	1)
R412004848	Protected against polarity reversal	1)
0830100371	Protected against polarity reversal	1)
0830100372	Protected against polarity reversal	1)
0830100375	short circuit resistant Protected against polarity reversal	2)
0830100378	Protected against polarity reversal	2)
0830100377	short circuit resistant Protected against polarity reversal	2)
0830100376	short circuit resistant Protected against polarity reversal	2)

1) without wire end ferrule, tin-plated, 2-pin

2) without wire end ferrule, tin-plated, 3-pin

## Technical information

If reed sensors are used, we recommend using a short-circuit protective device (SCPD).

## Technical information

### Material

Housing	Polyamide epoxy resin
Cable sheath	Polyvinyl chloride Polyurethane Thermoplastic elastomer

## Dimensions

### Dimensions

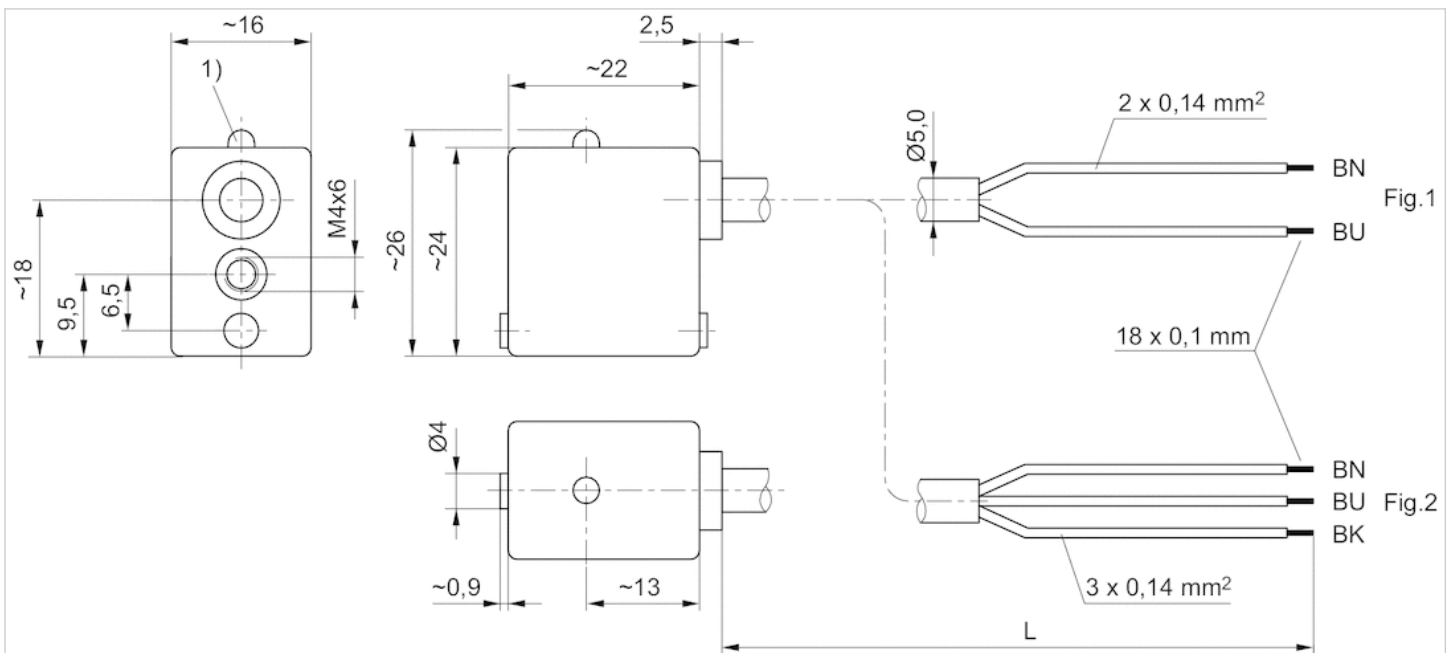

1) LED

L = cable length

BN = brown, BK = black, BU = blue











## Sensor, Series SN2

- Plug, M8, 2-pin Plug, M8, 3-pin Plug, M8, 4-pin
- Reed 2-Wire Reed 3-Wire Reed 3-Wire, with pulse stretching Reed 4-Wire electronic PNP
- With stretched impulse
- With stretched impulse
- Reed electronic PNP
- Indirect mounting for series TRB, PRA, ITS, MNI, CSL-RD, ICM, RPC, TRR, FLT, CVI



Ambient temperature min./max.	See table below
Protection class	IP67
Switching point precision	±0,1 mT
Nominal current, actuated state	15 mA
Quiescent current (without load)	10 mA
Min./max. DC operating voltage	See table below
Min./max. AC operating voltage	See table below
LED status display	See table below

## Technical data

Part No.		Type of contact	Min./max. DC operating voltage
0830100465		Reed	12 ... 36 V DC
0830100468		Reed	12 ... 36 V DC
R412004299		Reed	12 ... 36 V DC
0830100466		Reed	12 ... 36 V DC
0830100469		Reed	12 ... 36 V DC
R412004820		Reed	12 ... 36 V DC
0830100472		Reed	12 ... 36 V DC
0830100467		Reed	12 ... 36 V DC
0830100480		electronic PNP	10 ... 30 V DC
R412004800		electronic PNP	10 ... 30 V DC

Part No.	Min./max. AC operating voltage	Voltage drop U at I <sub>max</sub>
0830100465	12 ... 30 V AC	2,1 V + I*Rs
0830100468	12 ... 30 V AC	2,1 V + I*Rs
R412004299	12 ... 30 V AC	2,1 V + I*Rs
0830100466	12 ... 30 V AC	2,1 V + I*Rs
0830100469	12 ... 30 V AC	≤ 0,5 V
R412004820	12 ... 30 V AC	I*Rs
0830100472	12 ... 30 V AC	≤ 1,5 V
0830100467	12 ... 30 V AC	≤ 3,5 V
0830100480	12 ... 30 V AC	≤ 2,0 V
R412004800	-	≤ 2,0 V

Part No.	DC switching current, max.	AC switching current, max.
0830100465	0.13 A	0.13 A
0830100468	0.3 A	0.5 A
R412004299	0.13 A	0.13 A
0830100466	0.13 A	0.13 A
0830100469	0.13 A	0.13 A
R412004820	0.13 A	0.13 A
0830100472	0.2 A	0.13 A
0830100467	0.13 A	0.13 A
0830100480	0.13 A	-
R412004800	0.13 A	-

Part No.	Function	Ambient temperature min./max.
0830100465	Reed 2-Wire	-20 ... 80 °C
0830100468	Reed 2-Wire	-20 ... 80 °C
R412004299	Reed 3-Wire	-20 ... 80 °C
0830100466	Reed 3-Wire	-20 ... 80 °C
0830100469	Reed 3-Wire	-20 ... 80 °C

Part No.	Function	Ambient temperature min./max.
R412004820	Reed 3-Wire	-20 ... 80 °C
0830100472	Reed 3-Wire, with pulse stretching	-20 ... 70 °C
0830100467	Reed 4-Wire	-20 ... 80 °C
0830100480	electronic PNP	-10 ... 70 °C
R412004800	electronic PNP	-10 ... 70 °C

Part No.	Switching capacity	Protective resistor for reed	Vibration resistance
0830100465	10 W / 10 VA	27 Ω	30 g (50 - 2000 Hz)
0830100468	10 W / 10 VA	1,3 Ω	30 g (50 - 2000 Hz)
R412004299	10 W / 10 VA	27 Ω	30 g (50 - 2000 Hz)
0830100466	10 W / 10 VA	100 Ω	30 g (50 - 2000 Hz)
0830100469	5,5 W / 5,5 VA	27 Ω	30 g (50 - 1000 Hz)
R412004820	10 W / 10 VA	27 Ω	30 g (50 - 2000 Hz)
0830100472	5 W / 5 VA	-	35 g (50 - 2000 Hz)
0830100467	10 W / 10 VA	27 Ω	35 g (50 - 2000 Hz)
0830100480	-	-	-
R412004800	-	-	-

Part No.	Shock resistance	Max. switching frequency	Operating current, not switched
0830100465	100 g / 11 ms	-	-
0830100468	100 g / 11 ms	-	-
R412004299	100 g / 11 ms	-	-
0830100466	100 g / 11 ms	-	-
0830100469	100 g / 11 ms	-	-
R412004820	100 g / 11 ms	-	-
0830100472	50 g / 11 ms	-	-
0830100467	50 g / 11 ms	-	-
0830100480	-	2000 Hz	10 mA
R412004800	-	2000 Hz	10 mA

Part No.	Operating current, switched	Material Housing	LED status display
0830100465	-	Polyamide	Yellow
0830100468	-	Polyamide	Yellow
R412004299	-	Polyamide	Yellow
0830100466	-	Polyamide	Yellow
0830100469	-	Polyamide	Yellow
R412004820	-	epoxy resin	Yellow
0830100472	-	-	Red
0830100467	-	epoxy resin	Red
0830100480	15 mA	Polyamide	Yellow
R412004800	15 mA	epoxy resin	Yellow

Part No.	Version
0830100465	Protected against polarity reversal
0830100468	Protected against polarity reversal
R412004299	Protected against polarity reversal
0830100466	Protected against polarity reversal
0830100469	Protected against polarity reversal
R412004820	Protected against polarity reversal
0830100472	Protected against polarity reversal
0830100467	Protected against polarity reversal
0830100480	short circuit resistant Protected against polarity reversal
R412004800	short circuit resistant Protected against polarity reversal

Part No.	Switch signal	Fig.	
0830100465	-	Fig. 1	1)
0830100468	-	Fig. 1	1)
R412004299	-	Fig. 1	2)
0830100466	-	Fig. 1	1)
0830100469	-	Fig. 1	2)
R412004820	-	Fig. 1	2)
0830100472	With stretched impulse	Fig. 1	2)
0830100467	-	Fig. 2	3)
0830100480	-	Fig. 1	2)
R412004800	-	Fig. 1	2)

1) Plug M8, 2-pin

2) Plug M8, 3-pin

3) Plug M8, 4-pin

## Technical information

If reed sensors are used, we recommend using a short-circuit protective device (SCPD).

## Technical information

### Material

Housing	Polyamide epoxy resin
---------	-----------------------

## Dimensions

Fig. 1

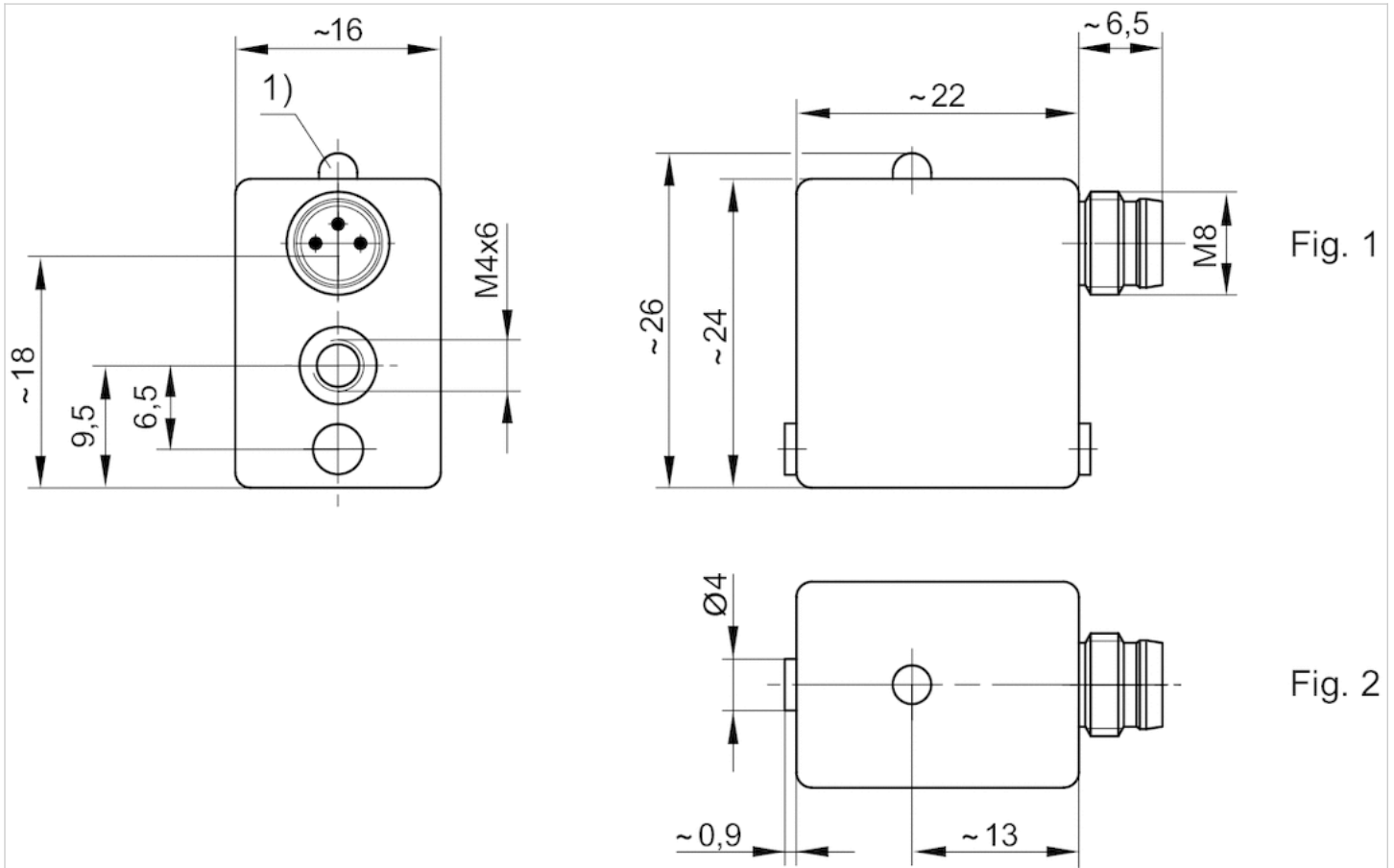

Fig. 1

Fig. 2

1) LED

M8: combination plug can be combined with valve plug connectors  $\varnothing 6.5$  mm and M8.

Pin assignments: 1 = (+), 3 = (-), 4 = (OUT), EN 60947-5-2:1998

Fig. 2

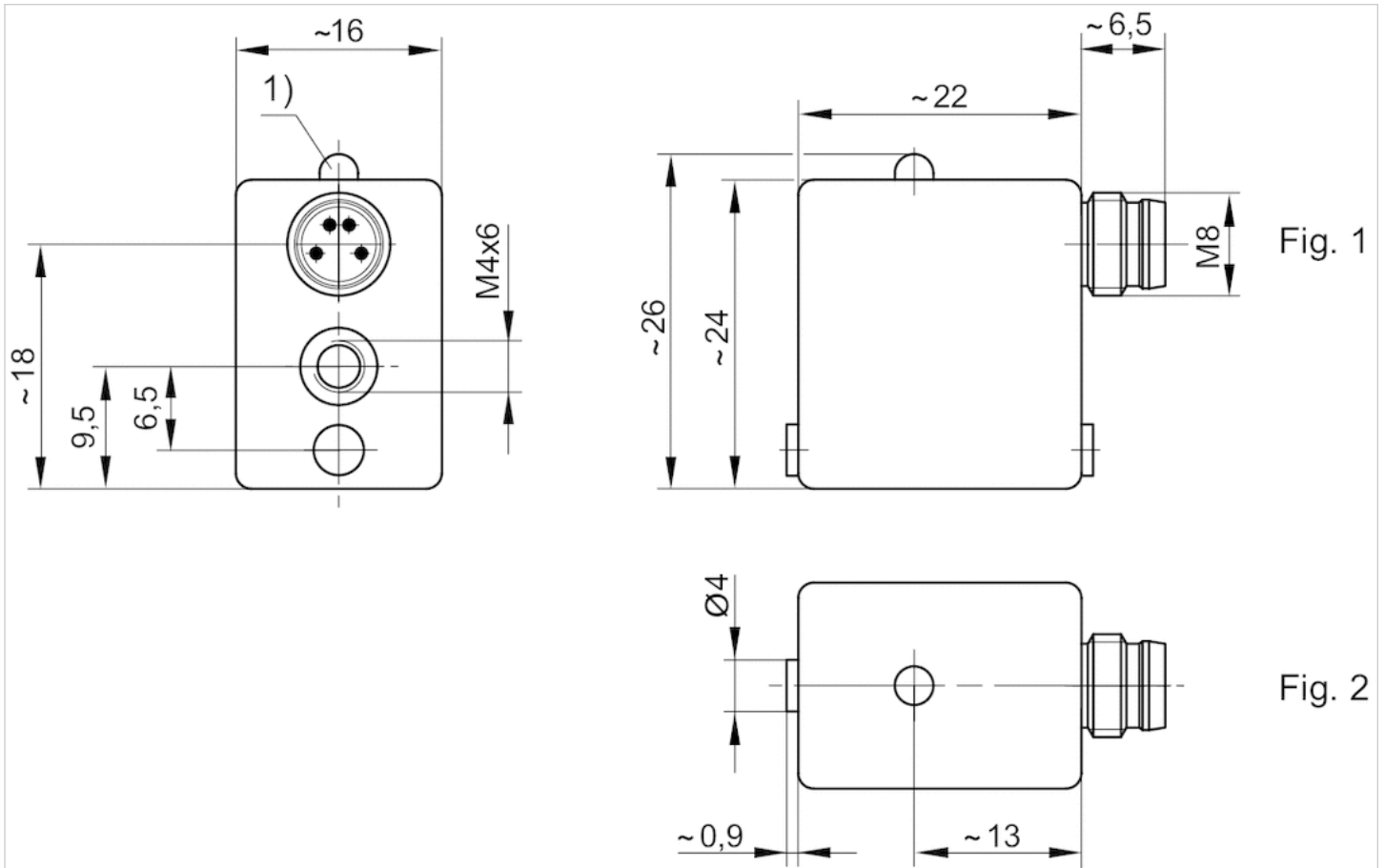

1) LED

M8: combination plug can be combined with valve plug connectors Ø6.5 mm and M8.

### Pin assignments

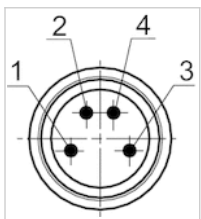

Pin	1	3	4
Allocation	(+)	(-)	(OUT)

EN 60947-5-2:1998



## Pin assignments

### Pin assignments

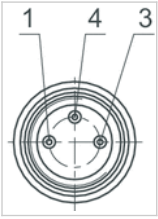

Pin	1	3	4
Allocation	(+)	(-)	(OUT)



# Sensor, Series SN6

- Plug, Form B, industry, 2-pin
- Reed
- Indirect mounting for series TRB, ITS, 523



Ambient temperature min./max.	-25 ... 75 °C
Protection class	IP65
Switching point precision	±0,1 mT
Min./max. DC operating voltage	10 ... 48 V DC
Min./max. AC operating voltage	10 ... 48 V AC
LED status display	See table below
Vibration resistance	35 g (50 - 2000 Hz)
Shock resistance	50 g / 11 ms

## Technical data

Part No.		Type of contact	DC switching current, max.
8940410602		Reed	3 A
8940410612		Reed	0.5 A

Part No.	AC switching current, max.	Switching capacity	LED status display
8940410602	3 A	60 W / 60 VA	-
8940410612	0.5 A	50 W / 50 VA	Yellow

Part No.	Version
8940410602	-
8940410612	Protected against polarity reversal

## Technical information

Material	
Housing	Polyester amide

## Dimensions

## Dimensions

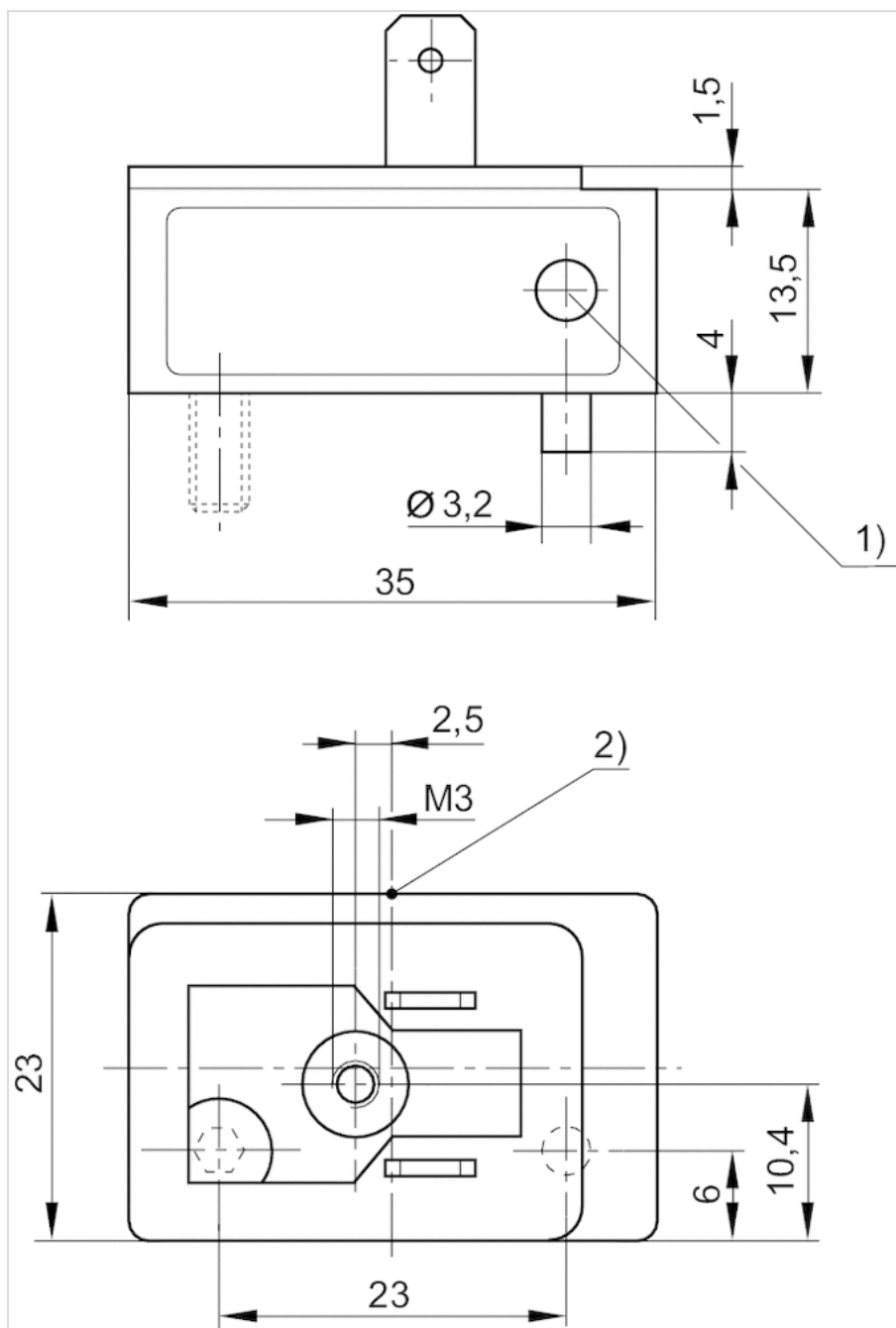

1) LED

2) Switching point

# Sensor, Series SN6

- Plug, Form B, industry, 2-pin
- ATEX
- Reed
- Indirect mounting for series TRB, ITS



Certificates	ATEX
ATEX class G	II 3G Ex nC nA IIC T4 Gc
ATEX class D	II 3D Ex tc IIIB/IIIC T125°C Dc
Ambient temperature min./max.	-10 ... 50 °C
Protection class	IP65
Switching point precision	±0,1 mT
Min./max. DC operating voltage	21.6 ... 26.4 V DC
Min./max. AC operating voltage	210 ... 240 V AC
LED status display	Yellow

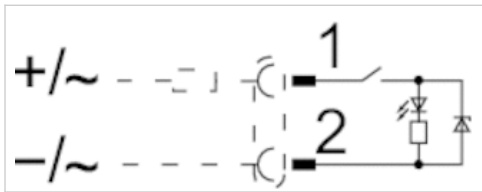

## Technical data

Part No.	Type of contact	DC switching current, max.	AC switching current, max.
R412000823	Reed	0.1 A	0.1 A

Part No.	Version
R412000823	Protected against polarity reversal

## Technical information

Material	
Housing	Polyester amide

## Dimensions

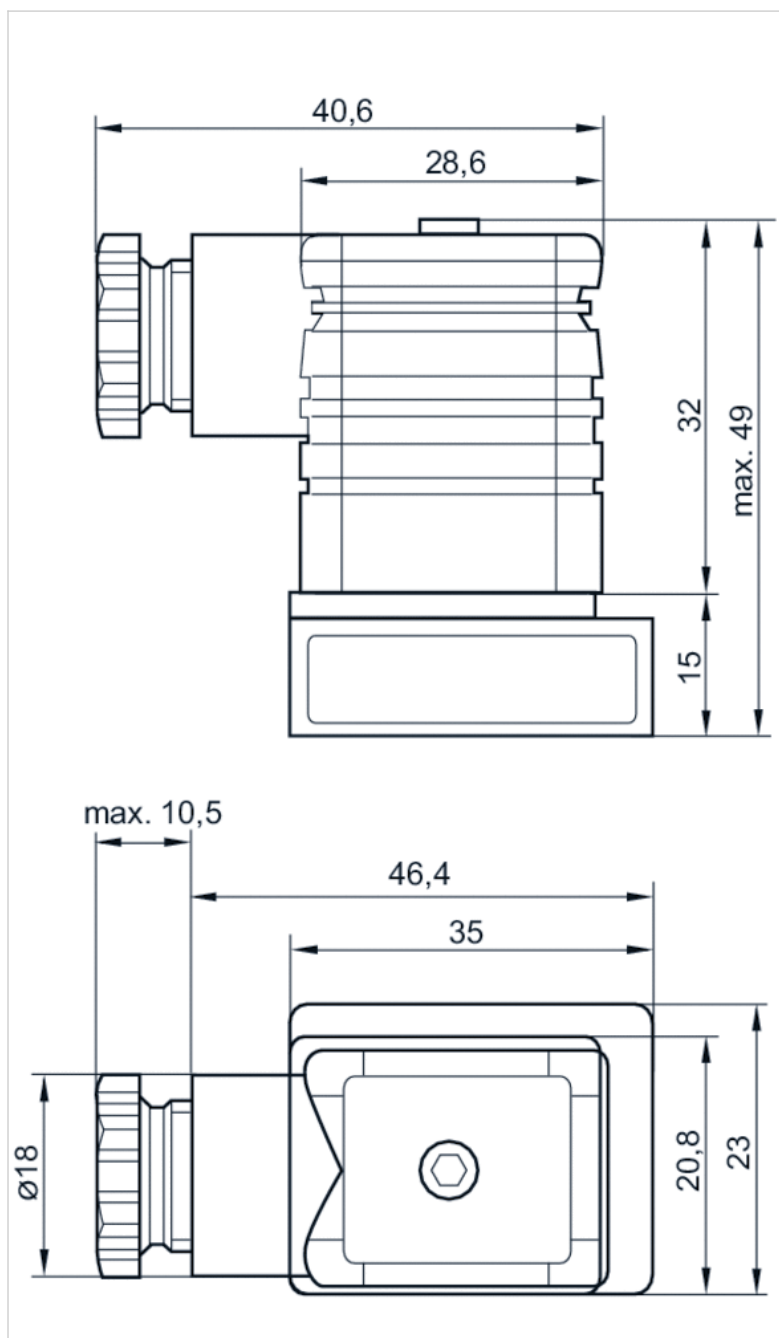

# Sensor, Series SN6

- with cable
- without wire end ferrule, tin-plated, 2-pin
- Heat resistant
- Reed
- Indirect mounting for series TRB, ITS



Ambient temperature min./max.	See table below
Protection class	IP67, IP65
Switching point precision	±0,1 mT
Min./max. DC operating voltage	10 ... 48 V DC
Min./max. AC operating voltage	10 ... 48 V AC
LED status display	Yellow
Vibration resistance	35 g (50 - 2000 Hz)
Shock resistance	50 g / 11 ms
Cable length L	2.5 6 m

## Technical data

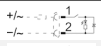
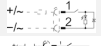
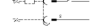
Part No.		Type of contact	Cable length L	DC switching current, max.
8940412022		Reed	2.5 m	0.5 A
8940412032		Reed	6 m	0.5 A
8940411902		Reed	2.5 m	3 A

Part No.	AC switching current, max.	Ambient temperature min./max.	Switching capacity
8940412022	0.5 A	-25 ... 75 °C	50 W / 50 VA
8940412032	0.5 A	-25 ... 75 °C	50 W / 50 VA
8940411902	3 A	-20 ... 105 °C	60 W / 60 VA

Part No.	Version
8940412022	Protected against polarity reversal
8940412032	Protected against polarity reversal
8940411902	Protected against polarity reversal

## Technical information

Material	
Housing	Polyester amide
Cable sheath	Polyvinyl chloride

## Dimensions

### Dimensions

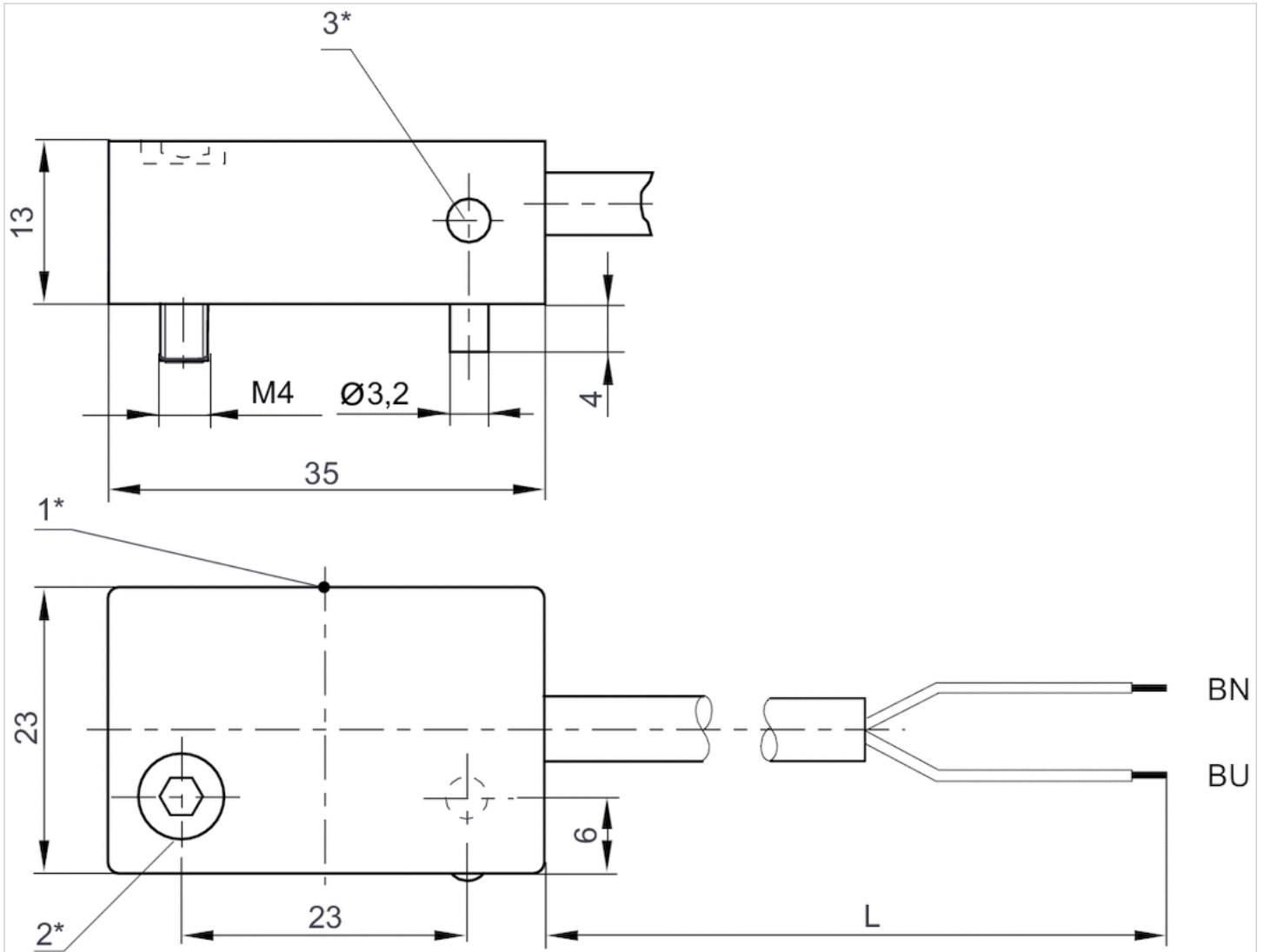

1\* = switching point 2\* = clamping screw 3\* = LED

L = cable length

BN=brown, BU=blue

# Series CAT

- Measuring instrument for adjusting the pneumatic cushioning
- for MNI, CSL-RD, CCL-IS, ICS, RPC, PRA/TRB, ITS



Certificates	CE declaration of conformity
Ambient temperature min./max.	0 ... 40 °C
Measurement range Min.	0.2 m/s
Measurement range Max.	2 m/s
LED status display	Green Yellow Red
Protection class	IP50
Weight	0.12 kg

## Technical data

Part No.	for series
R412026160	MNI, CSL-RD, CCL-IS, ICS, RPC, PRA/TRB, ITS

Scope of delivery: 1 measuring instrument, 2 fastening strips, 1 power pack 3.7 V, 1 USB charging cable, Operating instructions, QR code notice, 1 case with foam inlay

## Technical information

The CAT measuring instrument uses Bluetooth radio technology for wireless connection with the "Aventics" app, which is available free of charge in the Android/Play Store and/or the IOS/App Store.

## Technical information

Material	
Housing	Luran S



## Dimensions

### Dimensions

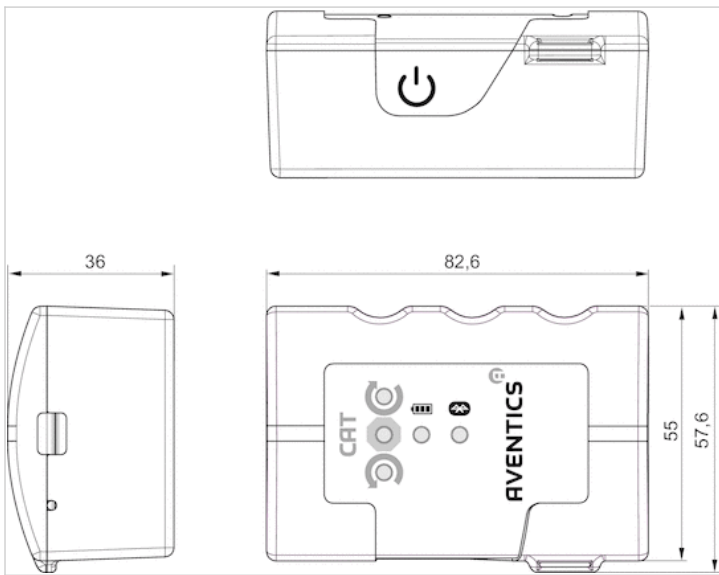

# Sensor mounting, Series CB1

- for series ST6, SN2, SN6, SN1, SM6, SM6-AL

- to mount on cylinder C12P, ITS



Weight

See table below

## Technical data

Part No.	Cylinders Ø		for series	Weight
	min.	max.		
R412017979	160 mm	200 mm	ST6, SN2, SN6, SN1, SM6, SM6-AL	0.058 kg
R412017980	250 mm	320 mm	ST6, SN2, SN6, SN1, SM6, SM6-AL	0.073 kg

Scope of delivery: Incl. mounting screws

## Technical information

Material	
	Aluminum

## Dimensions

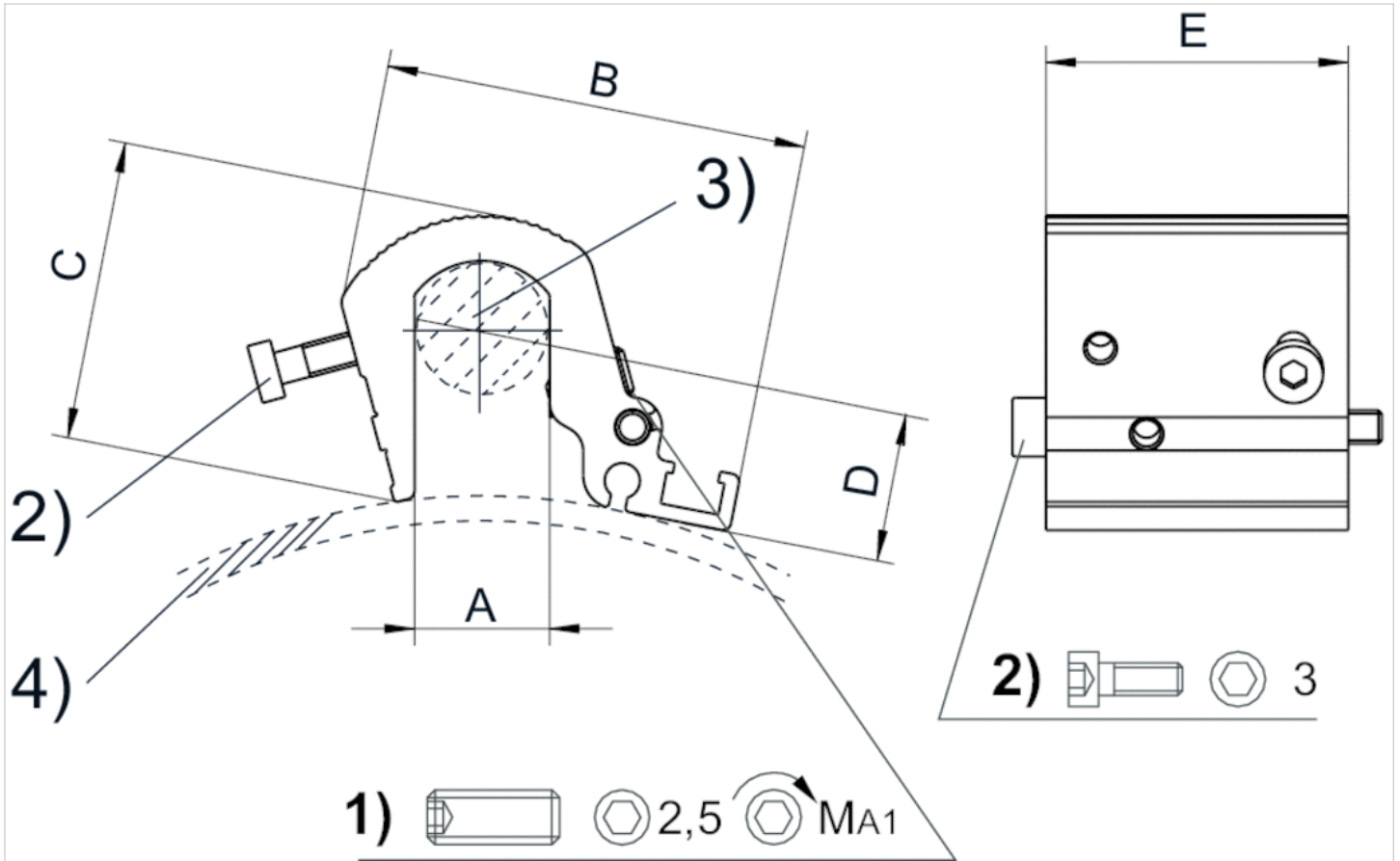

1) Clamping threaded pin 2) Mounting screws for sensor 3) Tie rod 4) Cylinder profile

## Dimensions

Part No.	Cylinders Ø	A	B	C	D	E	MA1 [Nm]
R412017979	200 mm	16	51	36	6.8	36	2
R412017980	320 mm	24	56	44.5	6.8	36	2

Scope of delivery: Incl. mounting screws

# Round plug connector, Series CON-RD

- Socket, M8x1, 3-pin, A-coded, straight, 180°
- UL (Underwriters Laboratories)
- unshielded



Connection type	Soldering
Ambient temperature min./max.	-25 ... 80 °C
Operational voltage	48 V AC/DC
Protection class	IP67
Weight	0.009 kg

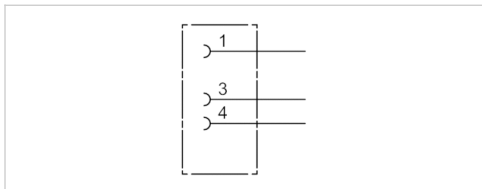

## Technical data

Part No.	Max. current	suitable cable-Ø min./max
1834484173	4 A	3.5 / 5 mm

## Technical information

The specified protection class is only valid in assembled and tested state.

## Technical information

Material	
Housing	Polyamide

## Dimensions

### Dimensions

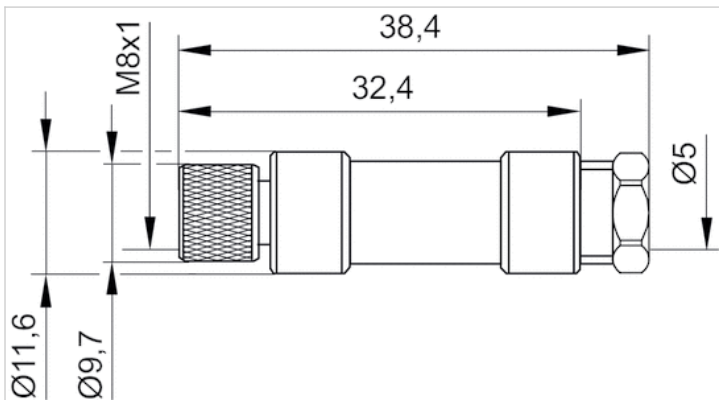

## Pin assignments

### Pin assignment, socket

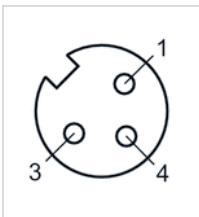

# Round plug connector, Series CON-RD

- Socket, M8x1, 3-pin, A-coded, angled, 90°
- UL (Underwriters Laboratories)
- unshielded



Connection type	Soldering
Ambient temperature min./max.	-40 ... 85 °C
Operational voltage	48 V AC/DC
Protection class	IP67
Weight	0.01 kg

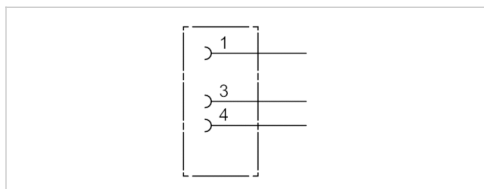

## Technical data

Part No.	Max. current	Contact assignment	suitable cable-Ø min./max
1834484174	4 A	3	3.5 / 5 mm

## Technical information

The specified protection class is only valid in assembled and tested state.

## Technical information

Material	
Housing	Polyamide

## Dimensions

### Dimensions

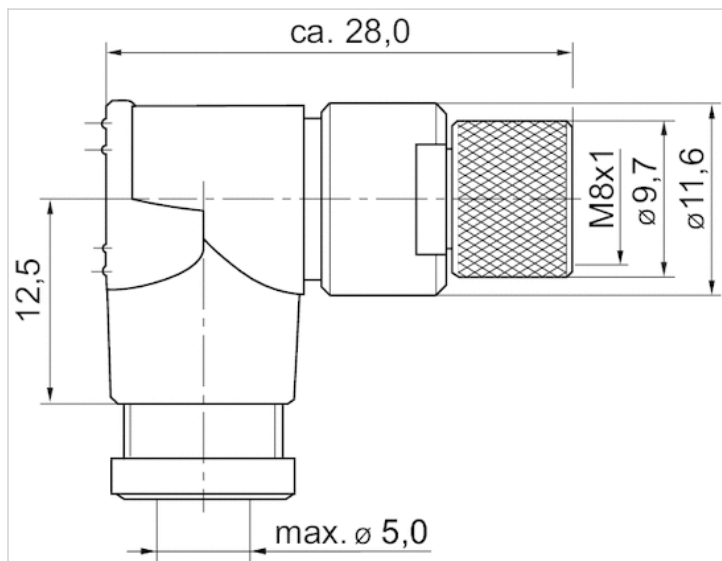

## Pin assignments

### Pin assignment, socket

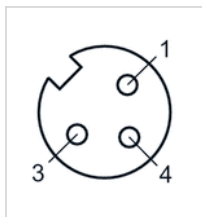

# Round plug connector, Series CON-RD

- Socket M8x1 3-pin A-coded straight 180°
- open cable ends
- with cable
- UL (Underwriters Laboratories)
- unshielded



Ambient temperature min./max.	-25 ... 85 °C
Operational voltage	48 V AC/DC
Protection class	IP67
Wire cross-section	0.24 mm <sup>2</sup>
Weight	See table below

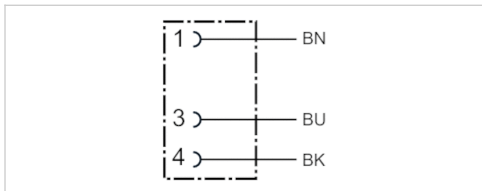

## Technical data

Part No.	Max. current	Number of wires	Cable-Ø	Cable length	Certification	Weight
1834484166	4 A	3	4.5 mm	3 m	UL (Underwriters Laboratories)	0.087 kg
1834484168	4 A	3	4.5 mm	5 m	UL (Underwriters Laboratories)	0.141 kg
1834484247	4 A	3	4.5 mm	10 m	UL (Underwriters Laboratories)	0.277 kg

## Technical information

The specified protection class is only valid in assembled and tested state.

## Technical information

Material	
Housing	Polyurethane
Cable sheath	Polyurethane



## Dimensions

### Dimensions

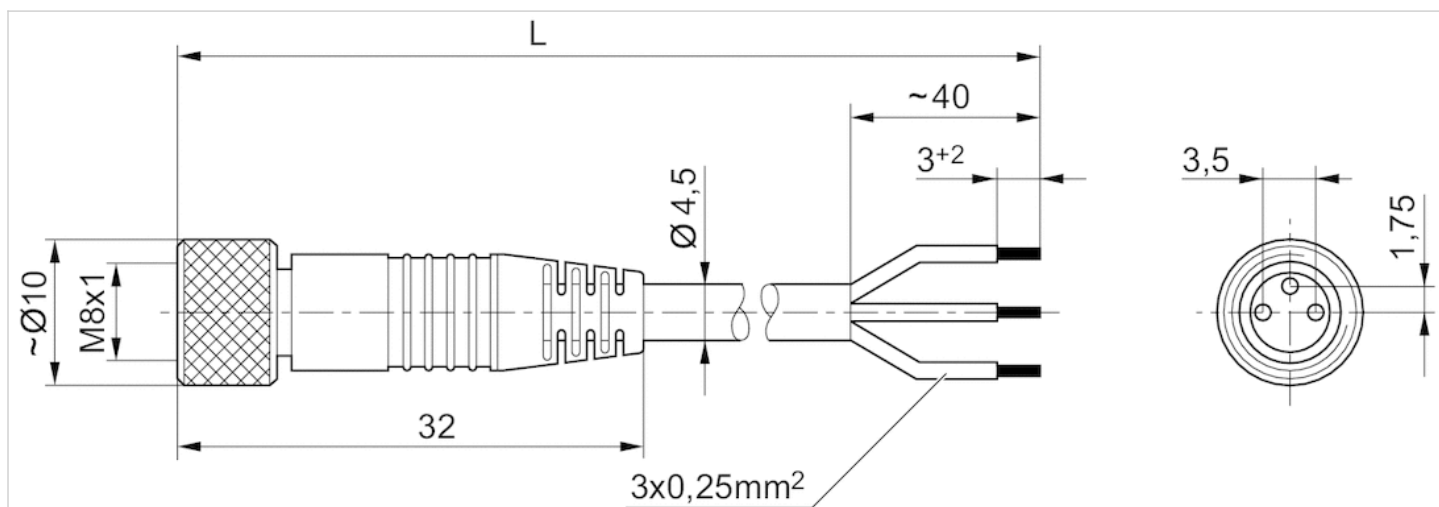

L = length

## Pin assignments

### Pin assignment, socket

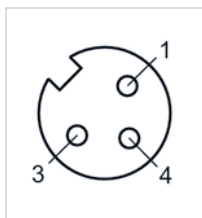

- (1) BN=brown
- (3) BU=blue
- (4) BK=black

# Round plug connector, Series CON-RD

- Socket M8x1 3-pin A-coded angled 90°
- open cable ends
- with cable
- unshielded



Ambient temperature min./max.	-40 ... 85 °C
Operational voltage	48 V AC/DC
Protection class	IP67
Wire cross-section	0.24 mm <sup>2</sup>
Weight	See table below

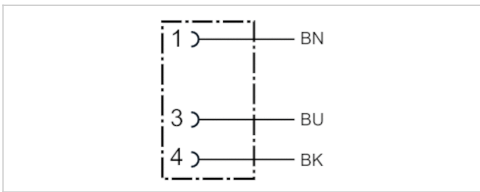

## Technical data

Part No.	Max. current	Number of wires	Cable-Ø	Cable length	Weight
1834484167	4 A	3	4.5 mm	3 m	0.087 kg
1834484169	4 A	3	4.5 mm	5 m	0.139 kg
1834484248	4 A	3	4.5 mm	10 m	0.279 kg

## Technical information

The specified protection class is only valid in assembled and tested state.

## Technical information

Material	
Housing	Polyurethane
Cable sheath	Polyurethane

## Dimensions

### Dimensions

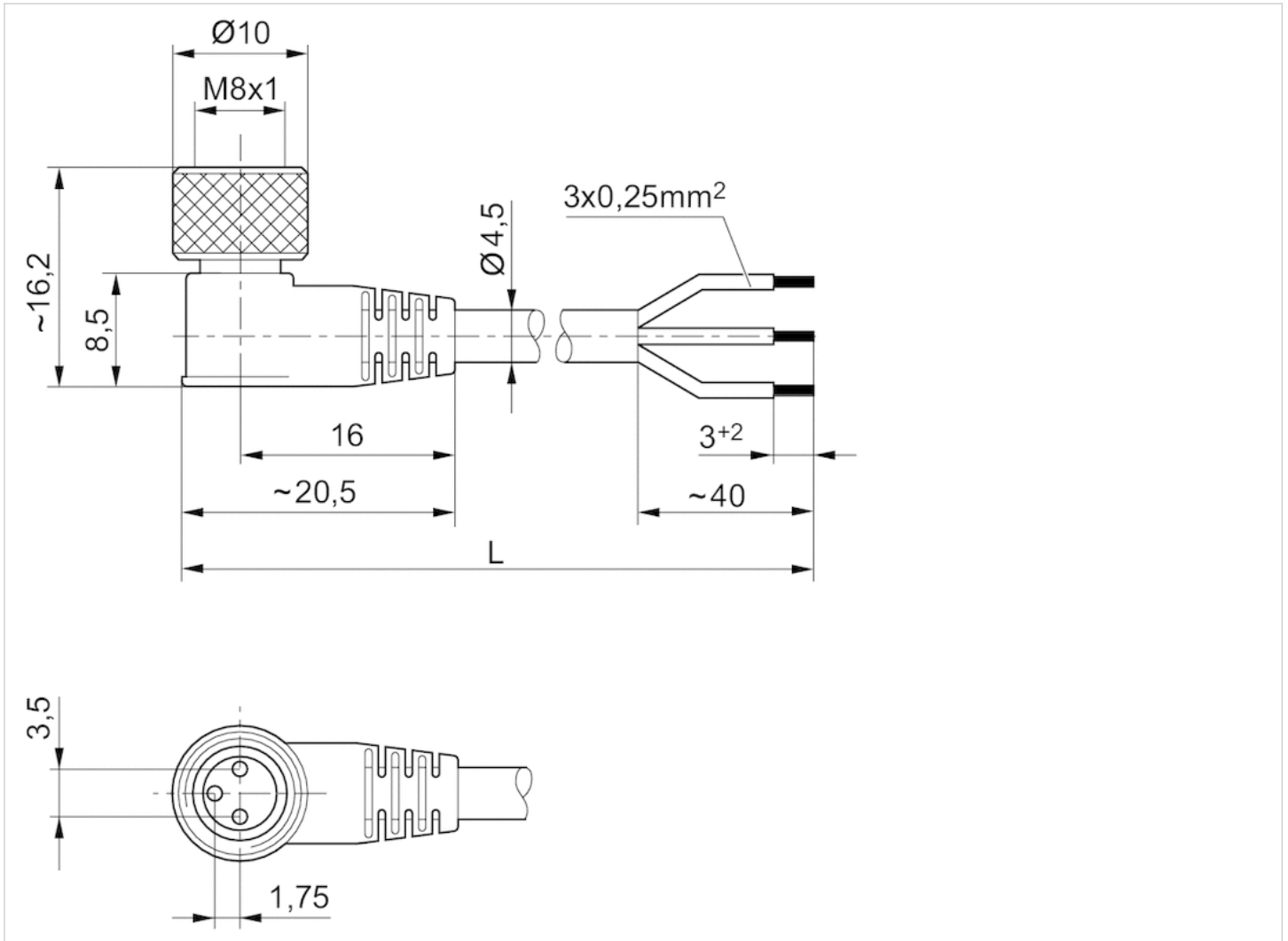

L = length

## Pin assignments

### Pin assignment, socket

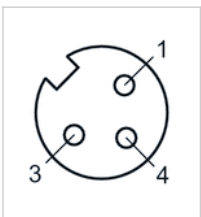

- (1) BN=brown
- (3) BU=blue
- (4) BK=black

# Compressed air tubing, Series TU1-S-PUR

- suitable for dynamic laying
- Ø 14-16 mm
- Polyester polyurethane
- Max. working pressure at 20 °C 10 bar

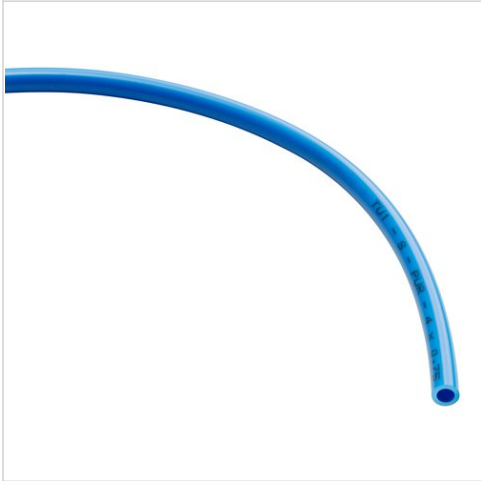

Max. working pressure at 20 °C 10 bar  
 Ambient temperature min./max. -30 ... 80 °C  
 Weight See table below

## Technical data

Part No.	external	Wall thickness	Color	Length	Bending radius min.	Weight per meter
	-Ø			Delivery unit	At 20 °C	
R412004778	14 mm	2 mm	Black	25 m	55 mm	0.092 kg
R412004780	16 mm	2.5 mm	Black	25 m	65 mm	0.129 kg
R412004781	16 mm	2.5 mm	Black	100 m	65 mm	0.129 kg
R412004779	14 mm	2 mm	Black	100 m	55 mm	0.092 kg

price / m

## Technical information

External calibrated  
 Suitable for dynamic laying  
 Halogen-free

## Technical information

Material

Material	Polyester polyurethane
----------	------------------------

## Diagrams

### Pressure-Temperature-Diagram

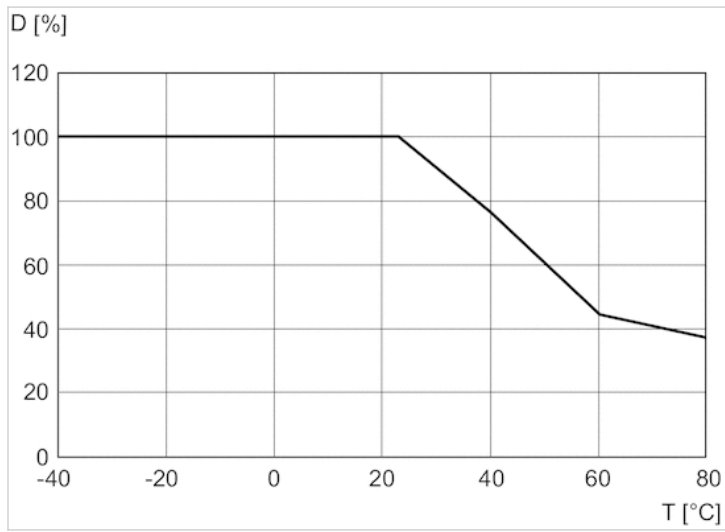

D = pressure resistance

T = temperature

# Silencers, series SI1

- G 3/4
- Sintered bronze



Working pressure min./max.	0 ... 10 bar
Ambient temperature min./max.	-25 ... 80 °C
Medium	Compressed air
Sound pressure level	92 dB
Weight	0.13 kg
Comment	Flow characteristic curves can be found under "Diagrams".

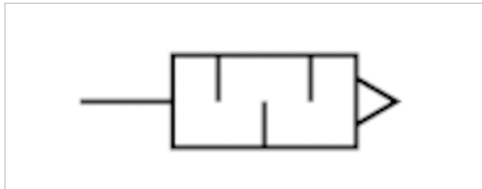

## Technical data

Part No.	Compressed air connection	Flow	Delivery unit
		Qn	
1827000004	G 3/4	8394 l/min	1 piece

Weight per piece

Nominal flow Qn at p1 = 6 bar (absolute) freely discharged. Sound pressure level measured at 6 bar against atmosphere at 1 m distance.

## Technical information

Material	
Silencer	Sintered bronze
Thread	Brass

## Dimensions

### Dimensions in mm

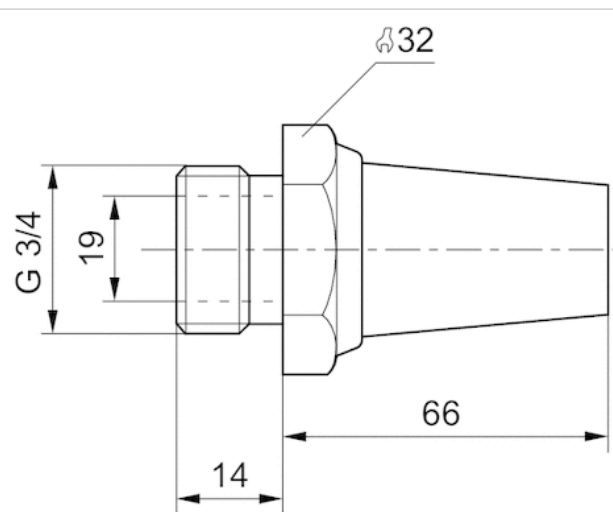

## Diagrams

### Flow diagram, 1827000004

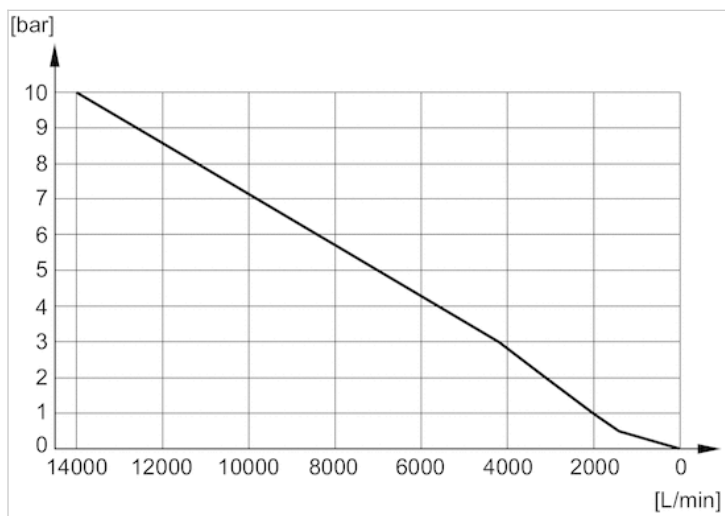

# Silencers, series SI1

- G 1

- Sintered bronze



Working pressure min./max.

0 ... 10 bar

Ambient temperature min./max.

-25 ... 80 °C

Medium

Compressed air

Sound pressure level

102 dB

Weight

0.18 kg

Comment

Flow characteristic curves can be found under "Diagrams".

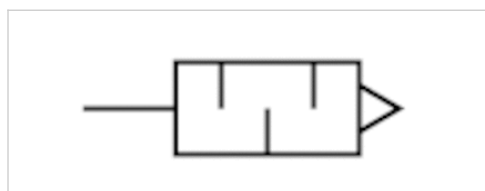

## Technical data

Part No.	Compressed air connection	Flow	Delivery unit
		Qn	
1827000005	G 1	12848 l/min	1 piece

Weight per piece

Nominal flow Qn at p1 = 6 bar (absolute) freely discharged. Sound pressure level measured at 6 bar against atmosphere at 1 m distance.

## Technical information

Material	
Silencer	Sintered bronze
Thread	Brass



## Dimensions

### Dimensions in mm

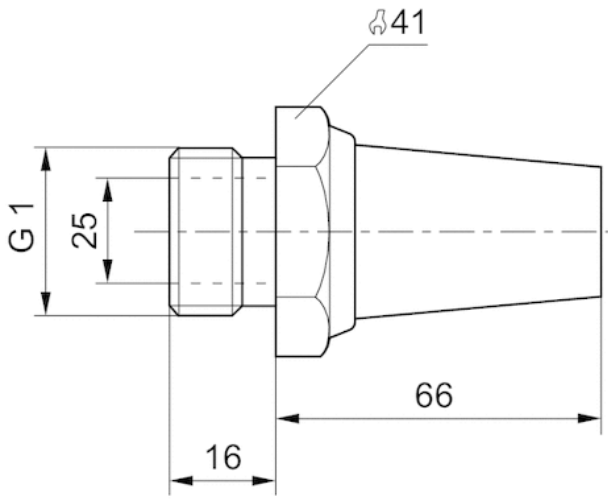

## Diagrams

### Flow diagram, 1827000005

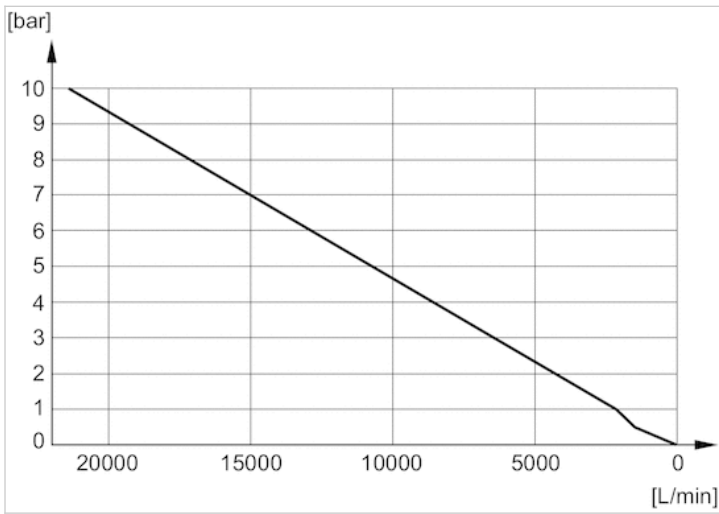

# Compressed air tubing, Series TU1-S-PAM

- suitable for dynamic laying
- Ø 14-16 mm
- Polyamide
- Max. working pressure at 20 °C 10-15 bar



Max. working pressure at 20 °C  
Ambient temperature min./max.  
Weight

See table below  
-40 ... 80 °C  
See table below

## Technical data

Part No.	external	Wall thickness	Color	Length	Bending radius min.	Weight per meter
	-Ø			Delivery unit	At 20 °C	
R412009927	14 mm	1.25 mm	Blue	25 m	90 mm	0.052 kg
1820712104	14 mm	1.5 mm	Natural	25 m	90 mm	0.052 kg
R412009936	14 mm	1.25 mm	Black	50 m	90 mm	0.052 kg
R412009929	16 mm	1.35 mm	Blue	25 m	100 mm	0.065 kg
R412009930	16 mm	1.35 mm	Blue	50 m	100 mm	0.065 kg

Part No.	Max. working pressure at 20 °C
R412009927	11 bar
1820712104	15 bar
R412009936	11 bar
R412009929	10 bar
R412009930	10 bar

price / m

## Technical information

External calibrated  
Halogen-free  
Excellent hydrolysis characteristics  
Suitable for dynamic laying  
Excellent UV resistance  
Resistant to microbes

## Technical information

Material

Material

Polyamide

# Reducing nipple

- External thread
- G 1
- Internal thread
- G 3/8 G 1/2 G 3/4
- FPT-S-RDZ



Working pressure min./max.

0 ... 60 bar

Ambient temperature min./max.

-20 ... 70 °C

## Technical data

Part No.	Port G	Port D	Delivery unit
1823391303	G 1	G 3/8	2 piece
1823391304	G 1	G 1/2	2 piece
1823391285	G 1	G 3/4	2 piece

## Technical information

Material	
Material	Brass, nickel-plated
Seal	Polyvinyl chloride, hard

## Dimensions

### Dimensions

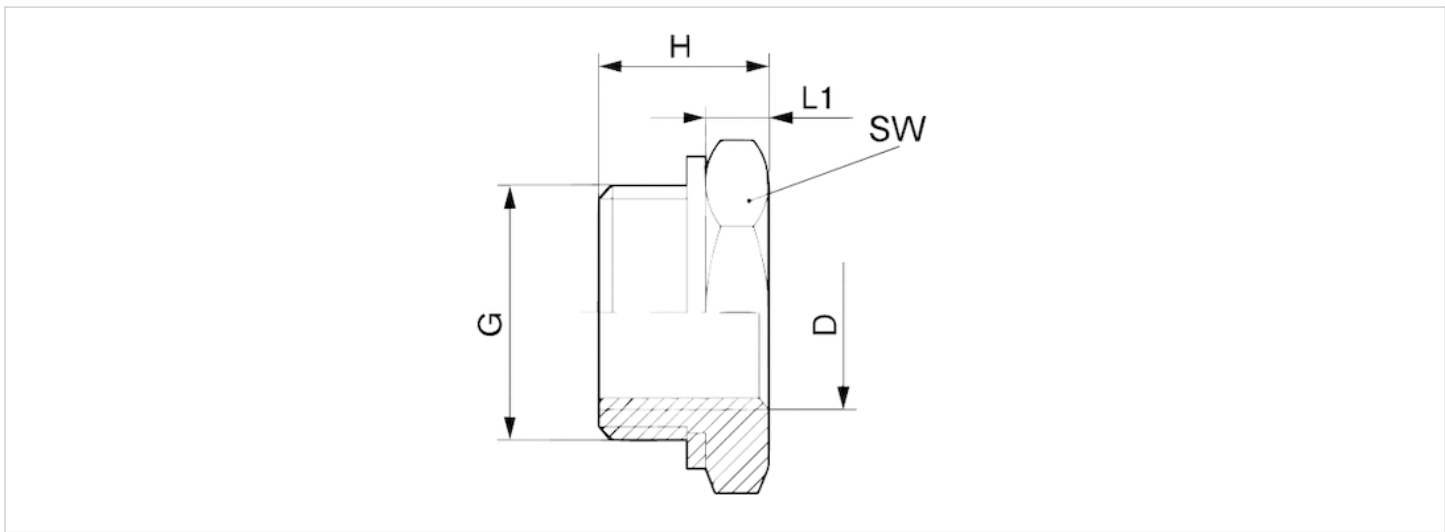

## Dimensions

Part No.	Port D	Port G	H	L1	SW
1823391303	G 3/8	G 1	23	8	41
1823391304	G 1/2	G 1	23	8	41
1823391285	G 3/4	G 1	23	8	41

# Straight fitting

- G 3/4



Working pressure min./max.

0 ... 10 bar

Ambient temperature min./max.

-20 ... 150 °C

## Technical data

Part No.	Port G
8938028550	G 3/4
8938028560	G 3/4

## Technical information

Material

Material	Steel
----------	-------

## Dimensions

Dimensions

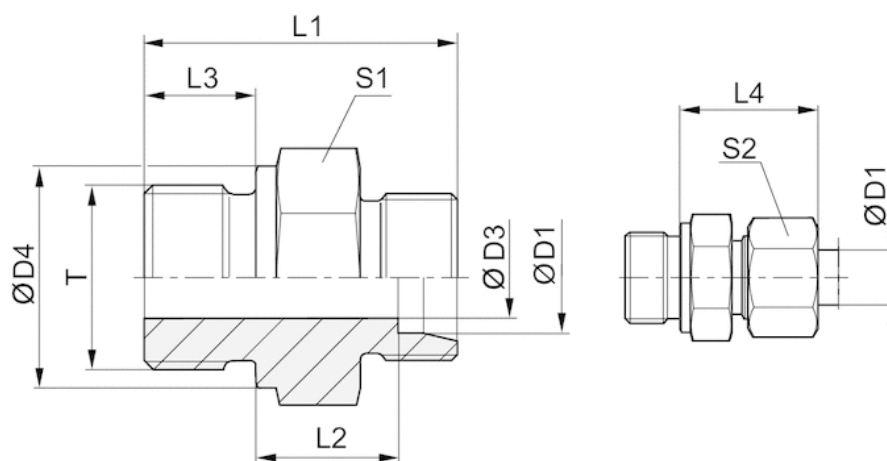

## Dimensions

Part No.	Port G	ØD1	ØD3	ØD4	L1	L2	L3	L4	S1	S2	T
8938028550	G 3/4	18	15	32	38	14,5	16	30	32	32	G3/4
8938028560	G 3/4	22	18	32	40	16,5	16	33	32	36	G3/4

# Efficient pneumatic solutions, our program: cylinders and drives, valves and valve systems, air supply management

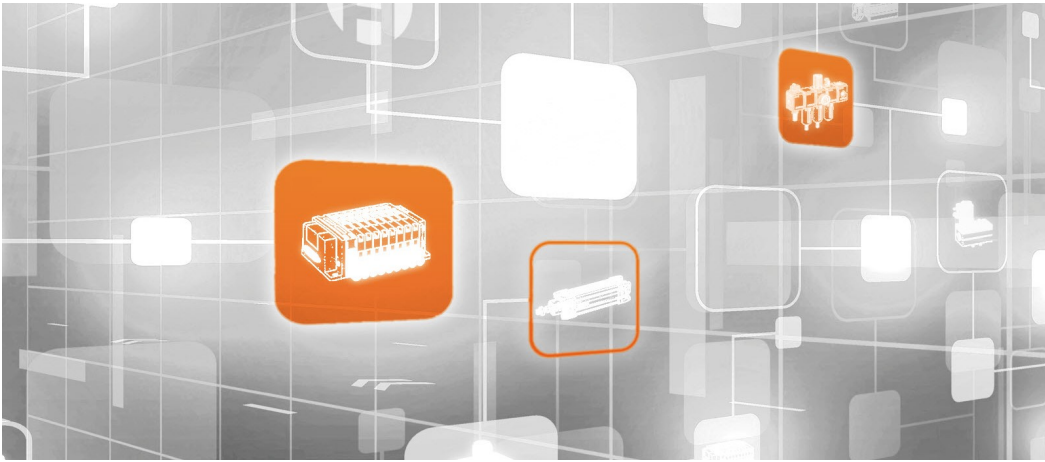

Visit us: [Emerson.com/Aventics](https://www.emerson.com/aventics)

Your local contact: [Emerson.com/contactus](https://www.emerson.com/contactus)



Emerson.com



[Facebook.com/EmersonAutomationSolutions](https://www.facebook.com/EmersonAutomationSolutions)



[LinkedIn.com/company/Emerson-Automation-Solutions](https://www.linkedin.com/company/Emerson-Automation-Solutions)



[Twitter.com/EMR\\_Automation](https://twitter.com/EMR_Automation)

An example configuration is depicted on the title page. The delivered product may thus vary from that in the illustration. Subject to change. This Document, as well as the data, specifications and other information set forth in it, are the exclusive property of AVENTICS GmbH. It may not be reproduced or given to third parties without its consent. Only use the AVENTICS products shown in industrial applications. Read the product documentation completely and carefully before using the product. Observe the applicable regulations and laws of the respective country. When integrating the product into applications, note the system manufacturer's specifications for safe use of the product. The data specified only serve to describe the product. No statements concerning a certain condition or suitability for a certain application can be derived from our information. The information given does not release the user from the obligation of own judgment and verification. It must be remembered that the products are subject to a natural process of wear and aging.

The Emerson logo is a trademark and service mark of Emerson Electric Co. Brand logotype are registered trademarks of one of the Emerson family of companies. All other marks are the property of their respective owners. © 2017 Emerson Electric Co. All rights reserved.  
2019-03



**CONSIDER IT SOLVED™**