

Guide units

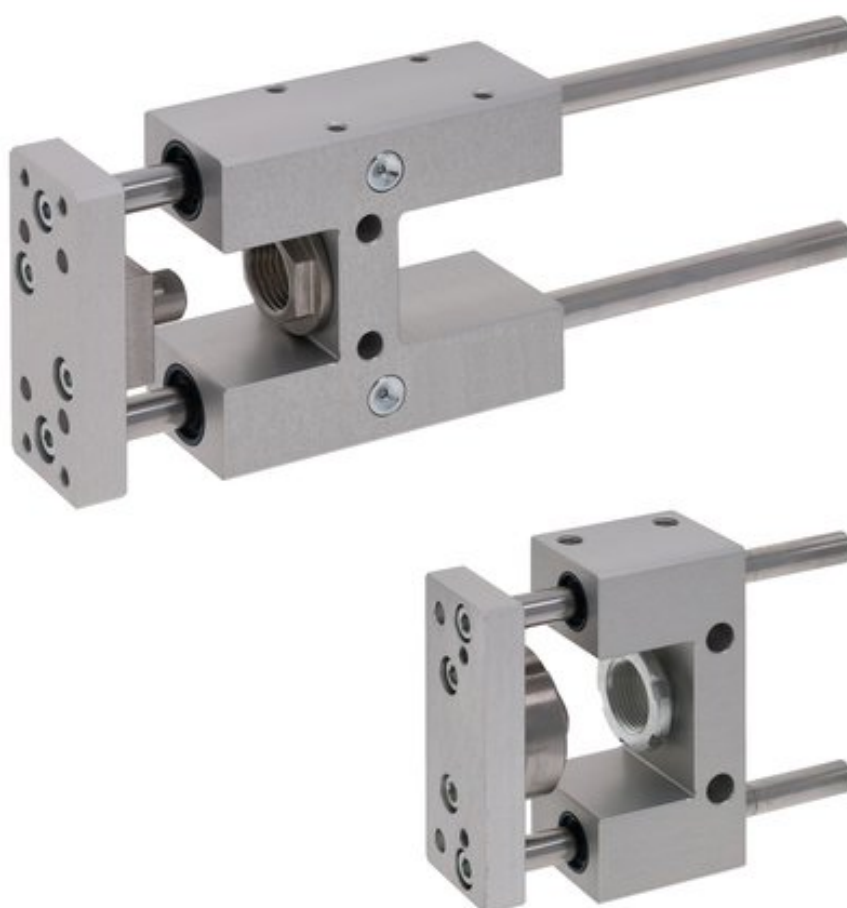

AVENTICS™ Guide units



Guide unit GU1, Series CG1

- Ø 12-25 mm
- Plain bearing
- For standard cylinders ISO 6432



Bearing type

Plain bearing

Ambient temperature min./max.

-20 ... 80 °C

Technical data

Suitable piston Ø	12 mm	20 mm	25 mm
Stroke 50	0821401095	0821401070	0821401080
100	0821401096	0821401071	0821401081
160	-	0821401072	0821401082
200	0821401097	0821401073	0821401083
250	-	0821401074	0821401084
400	-	0821401075	0821401085
600	-	-	0821401086
800	-	0821401077	0821401087
1000	-	0821401078	-

Technical data

Suitable piston Ø	12 mm	20 mm	25 mm
Weight 0 mm stroke	0.247 kg	0.66 kg	0.66 kg
+10 mm stroke	0.008 kg	0.012 kg	0.012 kg

Technical information

Guide units for cylinder Ø 12 also fit on cylinder Ø 16

Technical information

Material	
Bearing housings	Aluminum, colorless anodized
Bearing type	Sintered bronze
Carrying plate	Aluminum, colorless anodized

Material	
Flexible coupling in carrying plate	Stainless steel
Guide rods	Hardened heat-treated steel, ground

Dimensions

Ø 12

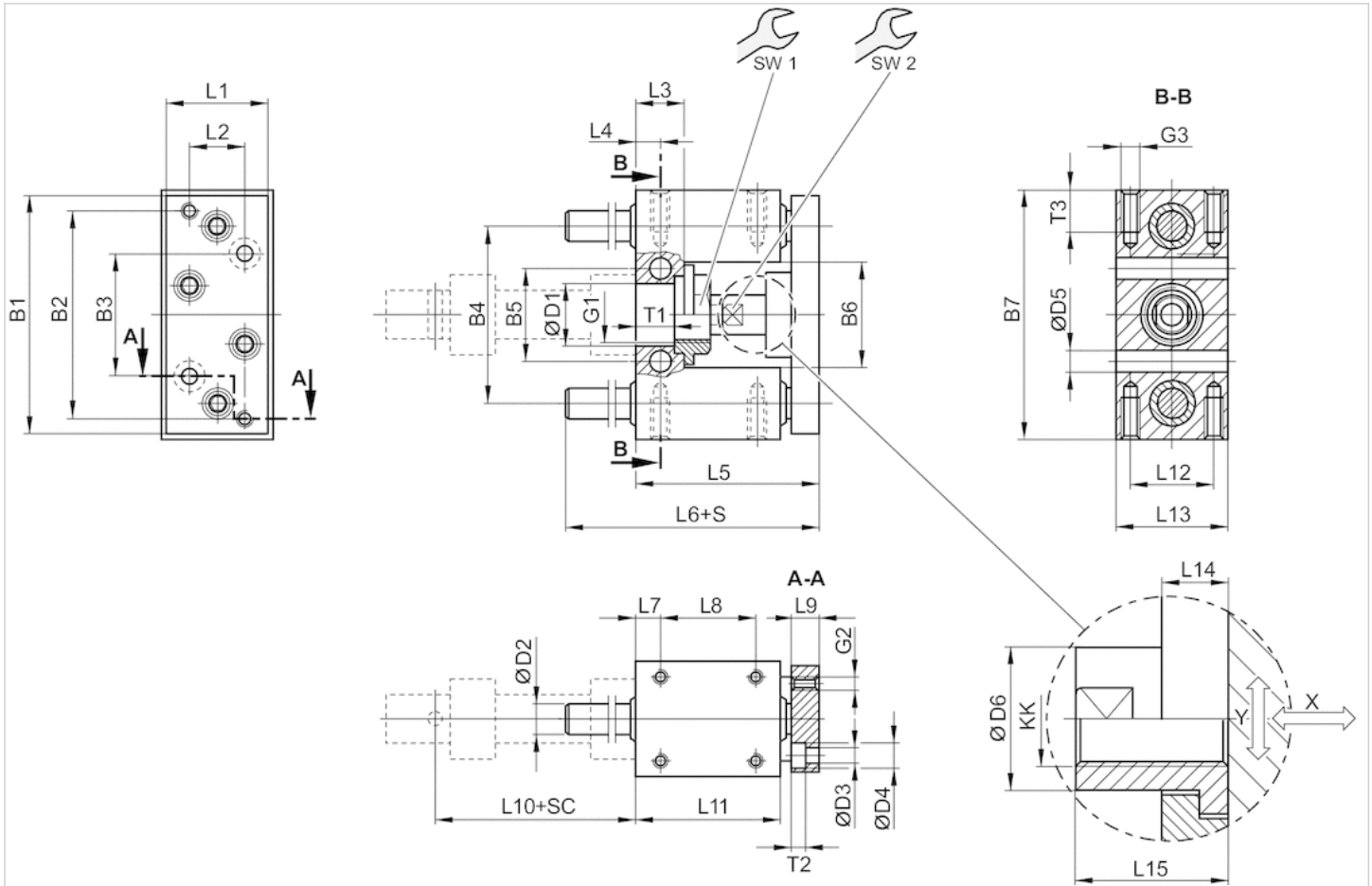

- S = stroke
- SC = cylinder stroke
- X = max. play (axial)
- Y = min. play (radial)

Dimensions

Piston Ø	B1	B2	B3	B4	B5	B6	B7	D1	D2	D3	D4	D5	D6	G1	G2	G3	KK	L1	L2	L3	L4	L5	L6
12 mm	63	54	32	46	24	27	65	16 H7	8	4.5	8	5.5	10	M16x1,5	M4	M4	M6	27	15	13	6.5	53	73

Piston Ø	L7	L8	L9	L10	L11	L12	L13	L14	L15	SW1	SW2	T1	T2	T3
12 mm	6.5	25	10	52.6	38	22	30	7	18	19	8	10.6	4.6	8

Dimensions

Ø 20 ... 25 mm

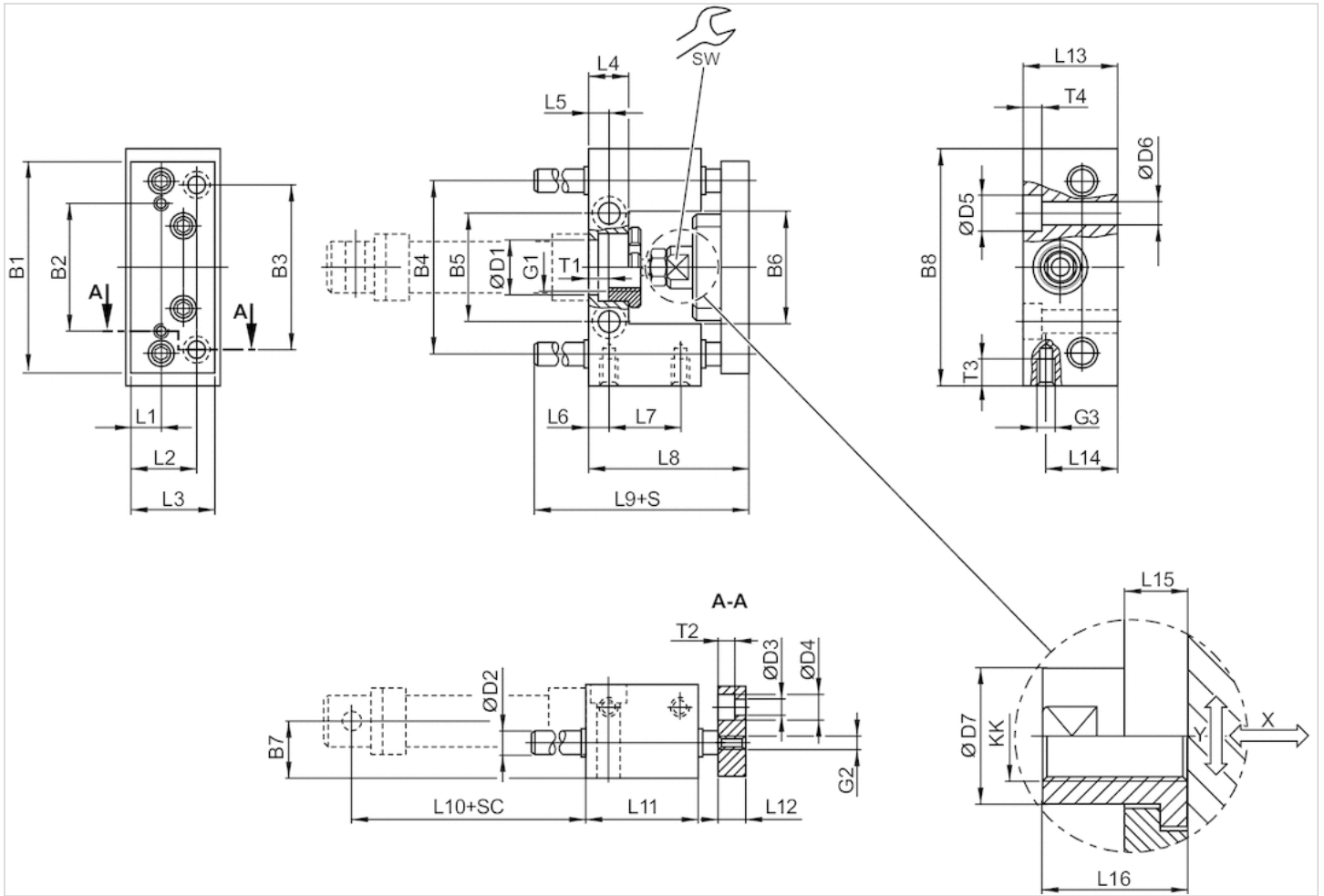

S = stroke
 SC = cylinder stroke
 X = max. play (axial)
 Y = min. play (radial)

Dimensions

Piston Ø	B1	B2	B3	B4	B5	B6	B7	B8	D1	D2	D3	D4	D5	D6	D7	G1	G2	G3	KK	L1
20 mm	90	55	70	74	46.5	48	24	100	22 H7	10	6.6	11	15	9	18	M22x1,5	M6	M8	M8	14
25 mm	90	55	70	74	46.5	48	24	100	22 H7	10	6.6	11	15	9	18	M22x1,5	M6	M8	M10x1,25	14

Piston Ø	L2	L3	L4	L5	L6	L7	L8	L9	L10	L11	L12	L13	L14	L15	L16	T1	T2	T3	T4	SW
20 mm	29	38	17	8.5	8	32	65	77	71	48	12	40	30	14	22	8	7	14	9	15
25 mm	29	38	17	8.5	8	32	71	77	76	48	12	40	30	14	22	8	7	14	9	15

Diagrams

Useful load

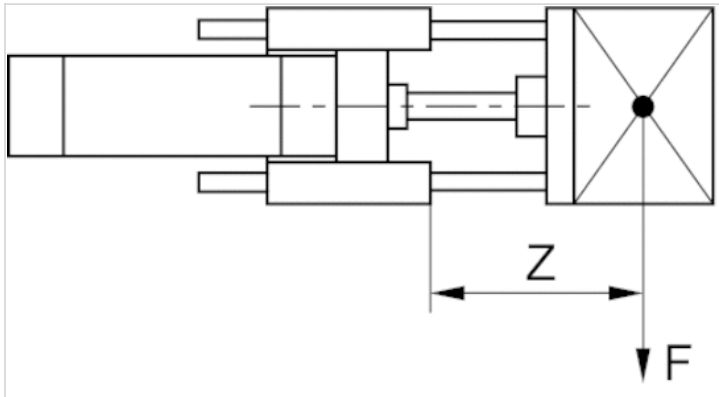

F = Useful load, Z = Projection

Useful load

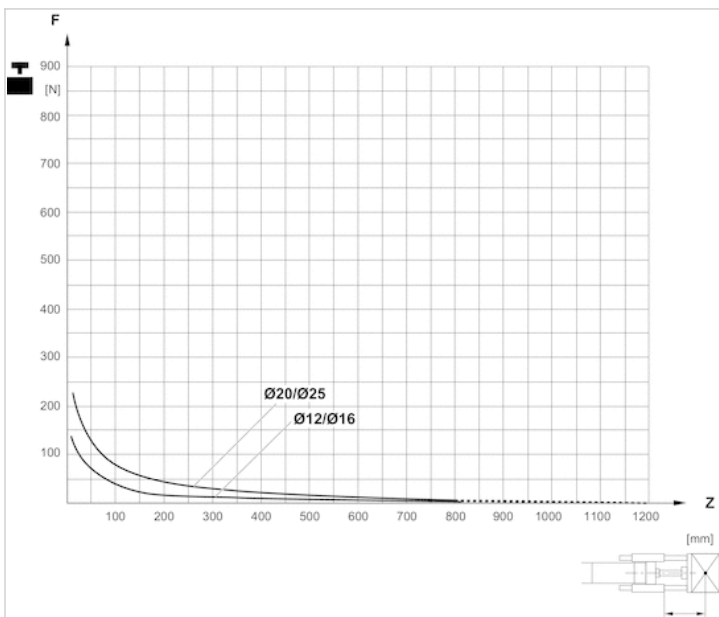

F = Useful load, Z = Projection

Guide unit GH1, Series CG1

- Ø 12-25 mm
- Plain bearing
- For standard cylinders ISO 6432



Bearing type	Plain bearing
Ambient temperature min./max.	-20 ... 80 °C

Technical data

Suitable piston Ø	12 mm	20 mm	25 mm
Stroke 50	0821401295	0821401200	0821401210
100	0821401296	0821401201	0821401211
160	-	0821401202	0821401212
200	0821401297	0821401203	0821401213
250	-	0821401204	0821401214
400	-	0821401205	0821401215
600	-	0821401206	0821401216
800	-	0821401207	0821401217

Technical data

Suitable piston Ø	12 mm	20 mm	25 mm
Weight 0 mm stroke	0.395 kg	0.73 kg	0.73 kg
+10 mm stroke	0.008 kg	0.012 kg	0.012 kg

Technical information

Guide units for cylinder Ø 12 also fit on cylinder Ø 16

Technical information

Material	
Bearing housings	Aluminum, colorless anodized
Bearing type	Sintered bronze
Carrying plate	Aluminum, colorless anodized
Flexible coupling in carrying plate	Stainless steel

Material	
Guide rods	Hardened heat-treated steel, ground

Dimensions

Ø 12 ... 25 mm

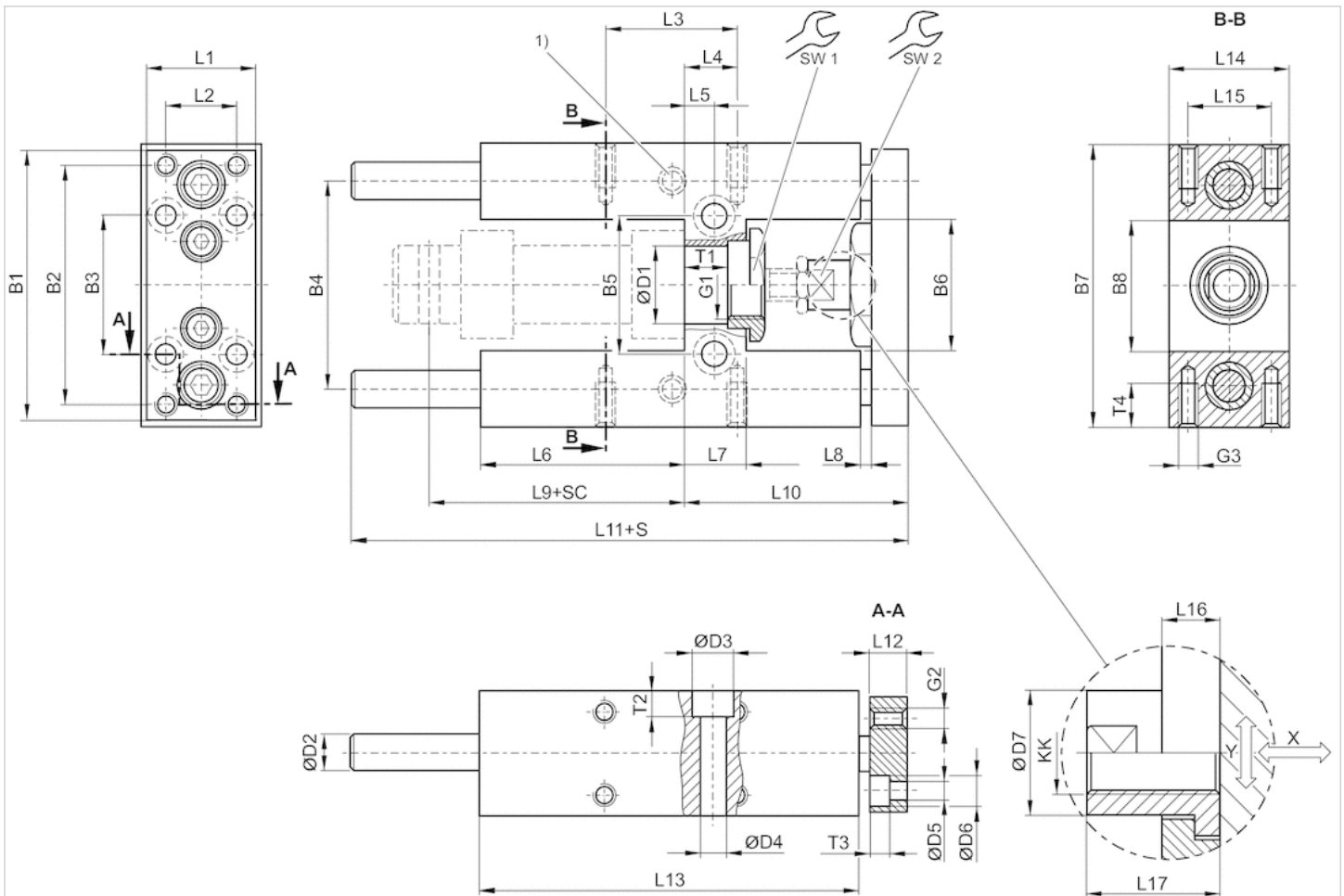

- 1) Lube nipple
- S = stroke
- SC = cylinder stroke
- X = max. play (axial)
- Y = min. play (radial)

Dimensions

Piston Ø	B1	B2	B3	B4	B5	B6	B7	B8	D1	D2	D3	D4	D5	D6	D7	G1	G2	G3	KK	L1
12 mm	63	54	32	46	24	27	65	27	16 H7	8	-	5.5	4.5	8	10	M16x1,5	M4	M4	M6	27
20 mm	76	68	40	58	38	37	79	37	22 H7	10	11	6.6	5.5	10.5	14.5	M22x1,5	M5	M6	M8	32
25 mm	76	68	40	58	38	37	79	37	22 H7	10	11	6.6	5.5	10.5	14.5	M22x1,5	M5	M6	M10x1,25	32

Piston Ø	L2	L3	L4	L5	L6	L7	L8	L9	L10	L11	L12	L13	L14	L15	L16	L17	SW1	SW2	T1	T2	T3
12 mm	15	32.5	11	6.5	37	13	3	52.6	51	133	10	75	30	22	7	18	19	8	10.6	-	4.6
20 mm	20	32.5	15	8.5	58	17	3	71	65	160.5	12	108	34	23	6	22	27	13	11	7	5.7
25 mm	20	32.5	15	8.5	58	17	3	76	65	160.5	12	108	34	23	6	17	27	13	11	7	5.7

Piston Ø	T4
12 mm	8
20 mm	14
25 mm	14

Diagrams

Useful load

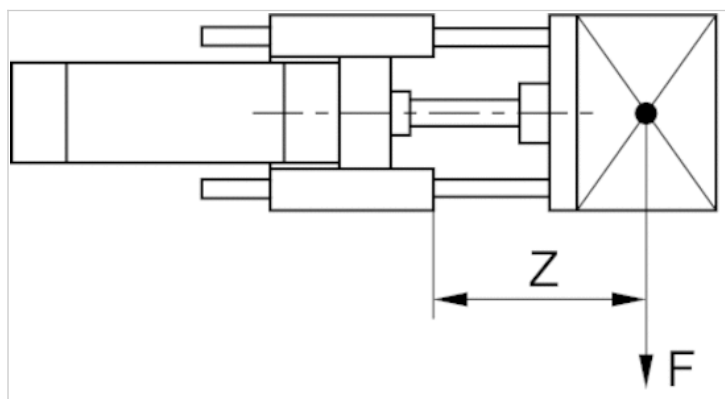

F = Useful load, Z = Projection

Useful load

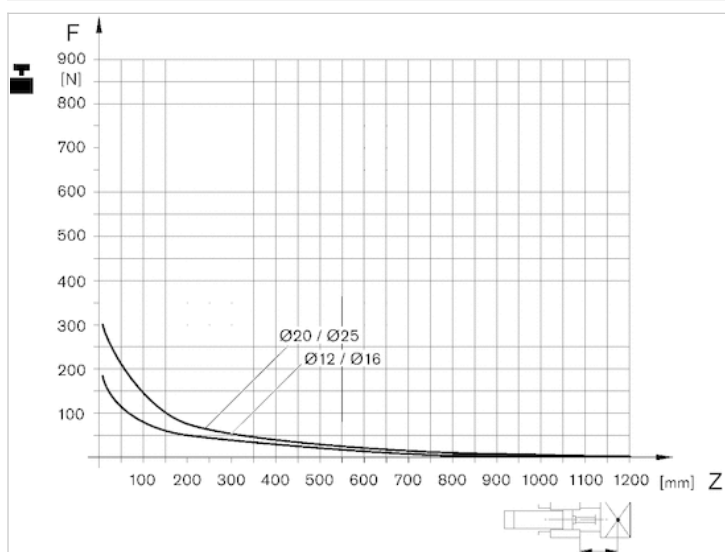

F = Useful load, Z = Projection

Bending due to own load

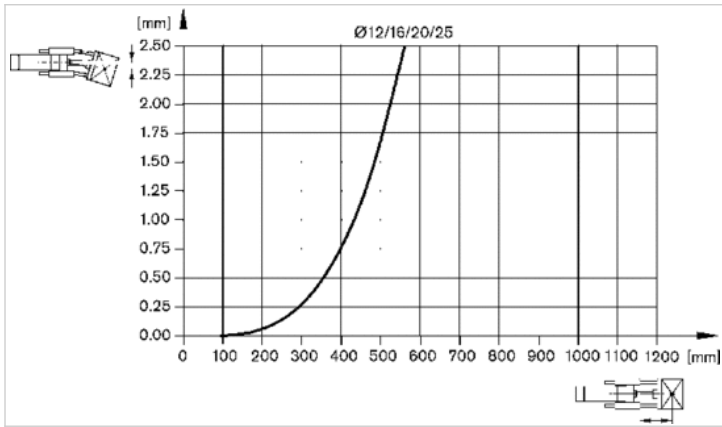

Bending due to 10 N load

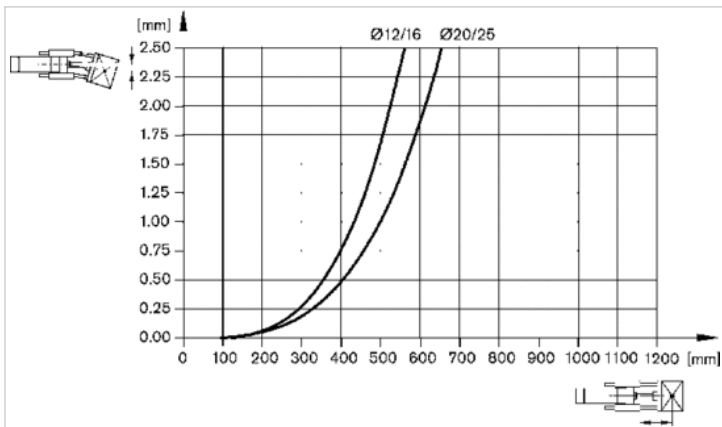

Guide unit GH2, Series CG1

- Ø 12-25 mm
- Linear ball bearing
- For standard cylinders ISO 6432



Bearing type

Linear ball bearing

Ambient temperature min./max.

-20 ... 80 °C

Technical data

Suitable piston Ø	12 mm	20 mm	25 mm
Stroke 50	0821401395	0821401300	0821401310
100	0821401396	0821401301	0821401311
200	0821401397	-	-
250	-	0821401302	0821401312
400	-	0821401303	0821401313
600	-	0821401304	0821401314
800	-	0821401305	0821401315

Technical data

Suitable piston Ø	12 mm	20 mm	25 mm
Weight 0 mm stroke	0.395 kg	0.73 kg	0.73 kg
+10 mm stroke	0.008 kg	0.012 kg	0.012 kg

Technical information

Guide units for cylinder Ø 12 also fit on cylinder Ø 16

Technical information

Material	
Bearing housings	Aluminum, colorless anodized
Bearing type	Steel
Carrying plate	Aluminum, colorless anodized
Flexible coupling in carrying plate	Stainless steel

Material	
Guide rods	Hardened heat-treated steel

Dimensions

Ø 12 ... 25 mm

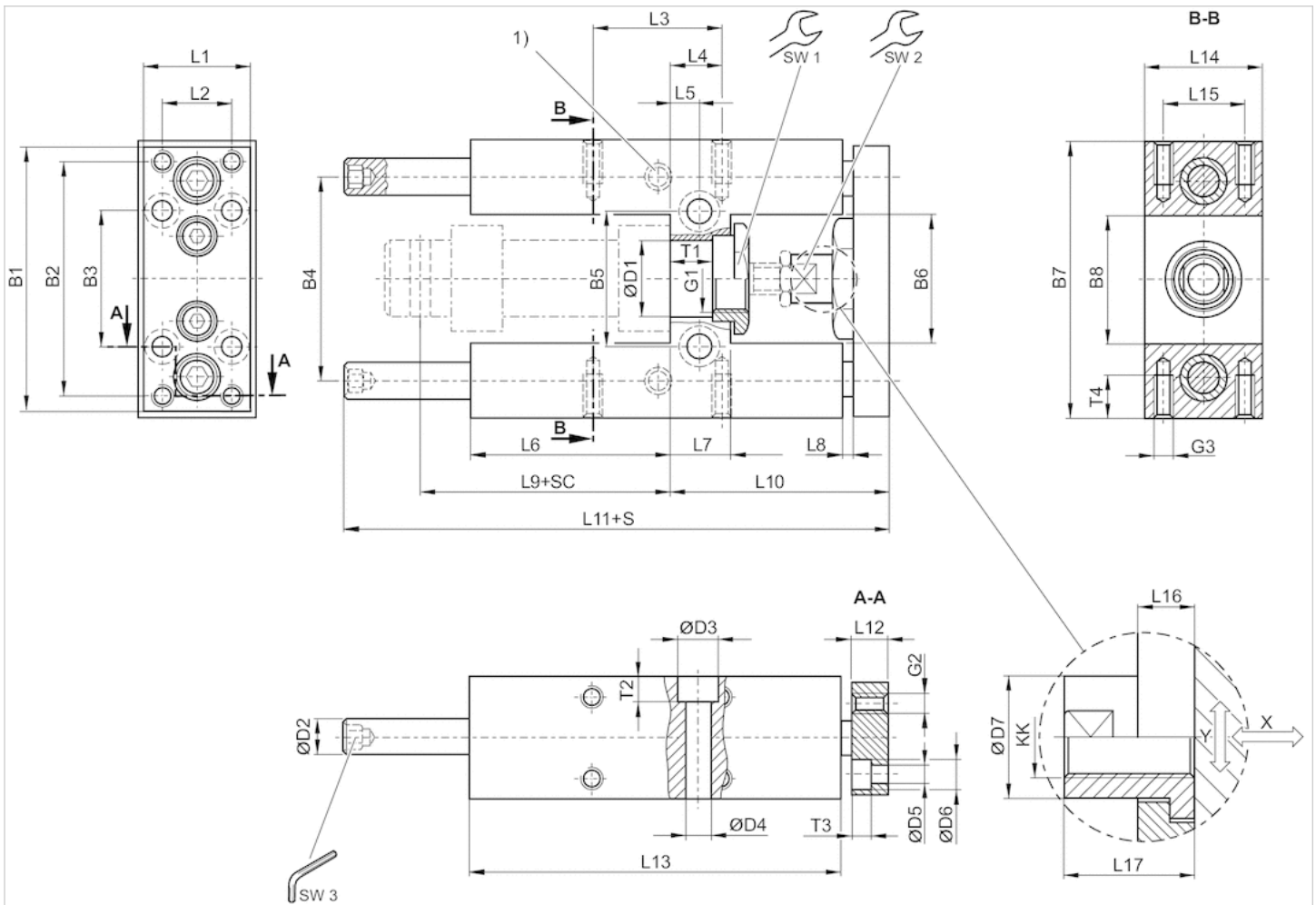

1) Lube nipple

S = stroke

SC = cylinder stroke

X = max. play (axial)

Y = min. play (radial)

Hexagon in guide rod

Dimensions

Piston Ø	B1	B2	B3	B4	B5	B6	B7	B8	D1	D2	D3	D4	D5	D6	D7	G1	G2	G3	KK	L1
12 mm	63	54	32	46	24	27	65	27	16 H7	8	-	5.5	4.5	8	10	M16x1,5	M4	M4	M6	27
20 mm	76	68	40	58	38	37	79	37	22 H7	10	11	6.6	5.5	10.5	14.5	M22x1,5	M5	M6	M8	32
25 mm	76	68	40	58	38	37	79	37	22 H7	10	11	6.6	5.5	10.5	14.5	M22x1,5	M5	M6	M10x1,25	32

Piston Ø	L2	L3	L4	L5	L6	L7	L8	L9	L10	L11	L12	L13	L14	L15	L16	L17	SW1	SW2	SW3	T1
12 mm	15	32.5	11	6.5	37	13	3	52.6	51	133	10	75	30	22	7	18	19	8	4	10.6
20 mm	20	32.5	15	8.5	58	17	3	71	65	160.5	12	108	34	23	6	22	27	13	5	11
25 mm	20	32.5	15	8.5	58	17	3	76	65	160.5	12	108	34	23	6	17	27	13	5	11

Piston Ø	T2	T3	T4
12 mm	-	4.6	8
20 mm	7	5.7	14
25 mm	7	5.7	14

Diagrams

Useful load

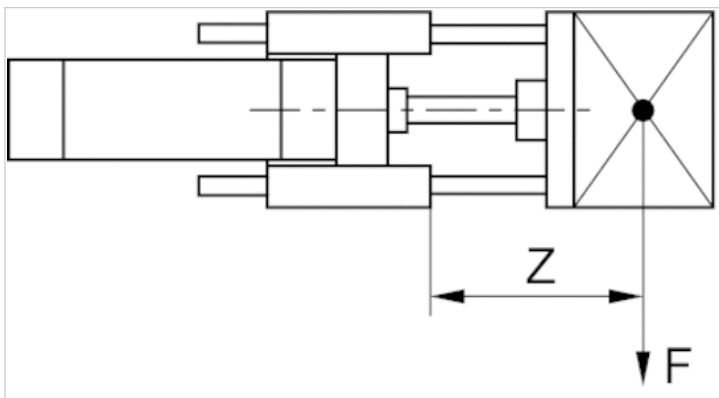

F = Useful load, Z = Projection

Useful load

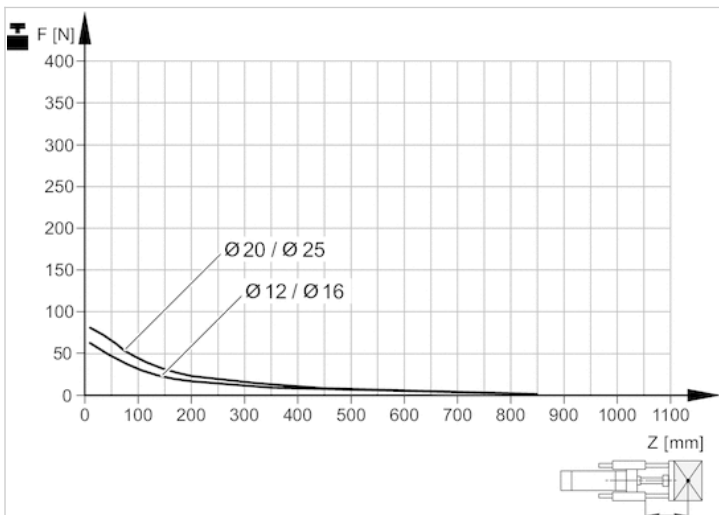

Service life 5×10^6 m

F = Useful load, Z = Projection

Bending due to own load

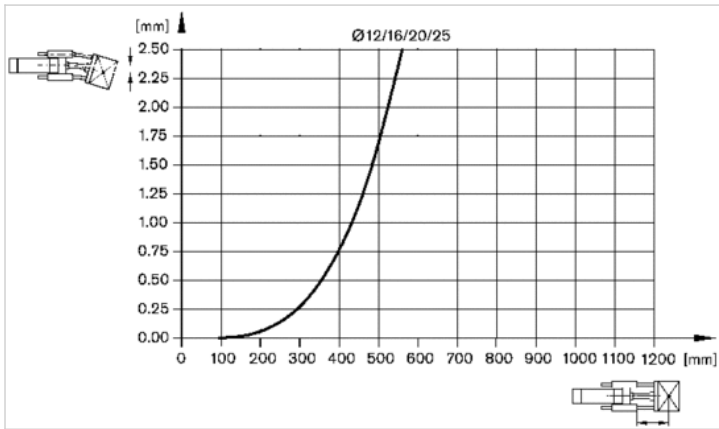

Bending due to 10 N load

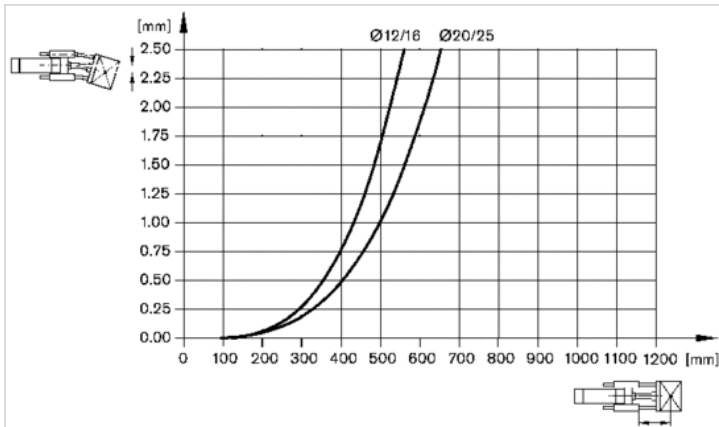

Guide unit GU1, Series CG1

- Ø 32-100 mm
- Plain bearing
- For standard cylinders ISO 15552



Bearing type

Plain bearing

Ambient temperature min./max.

-20 ... 80 °C

Technical data

Suitable piston Ø	32 mm	40 mm	50 mm	63 mm	80 mm	100 mm
Stroke 50	0821401010	0821401020	0821401030	0821401480	0821401050	0821401060
100	0821401011	0821401021	0821401031	0821401481	0821401051	0821401061
160	0821401012	0821401022	0821401032	0821401482	0821401052	0821401062
200	0821401013	0821401023	0821401033	0821401483	0821401053	0821401063
250	0821401014	0821401024	0821401034	0821401484	0821401054	0821401064
320	0821401015	0821401025	0821401035	0821401485	0821401055	0821401065
400	0821401016	0821401026	0821401036	0821401486	0821401056	0821401066
500	0821401017	0821401027	0821401037	0821401487	0821401057	0821401067
600	0821401018	0821401028	0821401038	0821401488	0821401058	0821401068
800	0821401019	0821401029	0821401039	0821401489	0821401059	0821401069
1000	0821401500	0821401502	0821401504	0821401490	0821401508	0821401510
1200	0821401501	0821401503	0821401505	0821401491	0821401509	0821401511

For use with hybrid inch cylinders with metric piston rod thread

Technical data

Suitable piston Ø	32 mm	40 mm	50 mm	63 mm	80 mm	100 mm
Weight 0 mm stroke	0.63 kg	0.946 kg	1.36 kg	1.66 kg	3.45 kg	4.69 kg
+10 mm stroke	0.012 kg	0.018 kg	0.018 kg	0.018 kg	0.022 kg	0.022 kg

Technical information

Material	
Bearing housings	Aluminum, colorless anodized
Bearing type	Sintered bronze
Carrying plate	Aluminum, colorless anodized

Material	
Flexible coupling in carrying plate	Stainless steel
Guide rods	Hardened heat-treated steel, ground

Dimensions

Ø 32 ... 100 mm

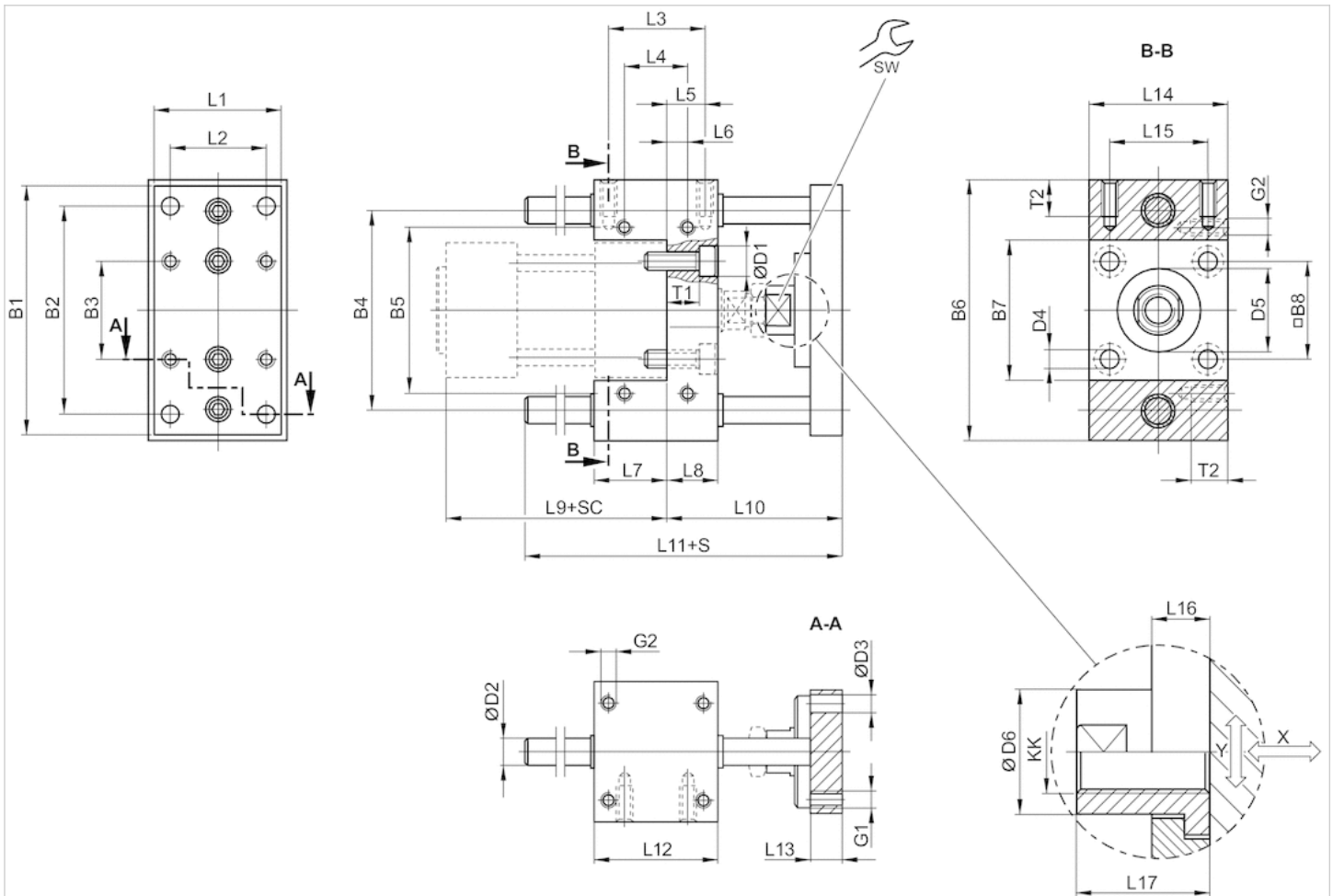

- S = stroke
- SC = cylinder stroke
- X = max. play (axial)
- Y = min. play (radial)

Dimensions

Piston Ø	B1	B2	B3	B4	B5	B6	B7	B8	D1	D2	D3	D4	D5	D6	G1	G2	KK	L1
32 mm	90	78	32.5	74	58	100	48	32.5	11	10	6.6	6.6	30 M8	18	M6	M6	M10x1,25	45
40 mm	100	84	38	80	64	106	54	38	11	12	6.6	6.6	35 M8	18	M6	M6	M12x1,25	50
50 mm	120	100	46.5	96	80	125	66	46.5	15	12	9	9	40 M8	24	M8	M8	M16x1,5	60
63 mm	125	105	56.5	104	95	132	76	56.5	15	12	9	9	45 M8	24	M8	M8	M16x1,5	70
80 mm	155	130	72	130	130	165	98	72	18	16	11	11	45 M8	30	M10	M10	M20x1,5	90
100 mm	175	150	89	150	150	185	118	89	18	16	11	11	55 M8	30	M10	M10	M20x1,5	110

Piston Ø	L2	L3	L4	L5	L6	L7	L8	L9	L10	L11	L12	L13	L14	L15	L16	L17	SW	T1	T2
32 mm	32.5	32.5	32.5	9.25	9.25	31	17	94	69	106	48	12	48	32.5	14	22	15	10	14
40 mm	38	38	38	11	11	37	21	105	74	117	58	12	56	38	14	22	15	14	14
50 mm	46.5	46.5	46.5	18.75	18.75	34	25	106	89	129	59	15	66	46.5	14	26	22	16	16
63 mm	56.5	56.5	56.5	15.25	15.25	51	25	121	89	146	76	15	76	56.5	14	26	22	16	16
80 mm	72	72	50	25	14	56	34	128	106	170	90	16	98	72	14	32	27	24	20
100 mm	89	89	70	28.5	19	71	39	138	111	190	110	16	118	89	14	32	27	29	20

Diagrams

Useful load

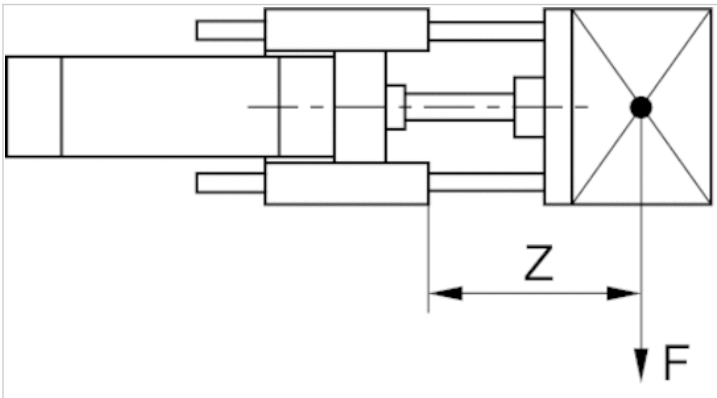

F = Useful load, Z = Projection

Useful load

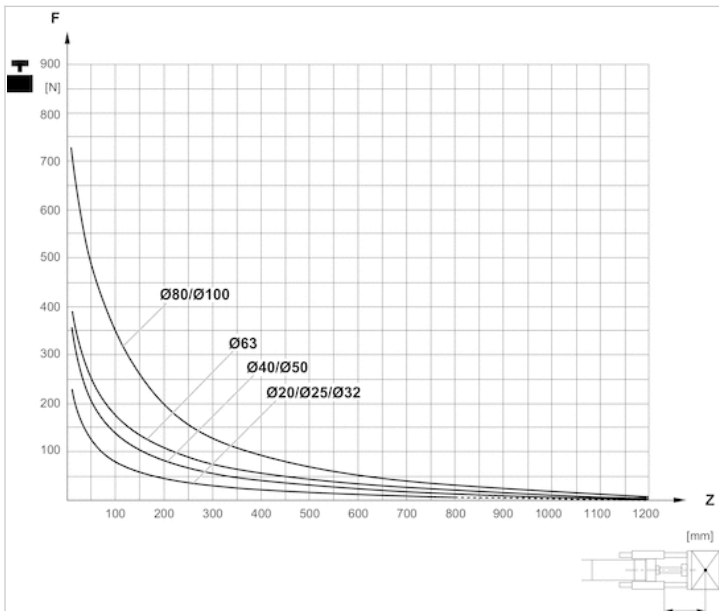

F = Useful load, Z = Projection

Guide unit GH1, Series CG1

- Ø 32-100 mm
- Plain bearing
- For standard cylinders ISO 15552



Bearing type

Plain bearing

Ambient temperature min./max.

-20 ... 80 °C

Technical data

Suitable piston Ø	32 mm	40 mm	50 mm	63 mm	80 mm	100 mm
Stroke 50	0821401220	0821401230	0821401240	0821401280	-	-
100	0821401221	0821401231	0821401241	0821401281	0821401260	0821401270
160	0821401222	0821401232	0821401242	0821401285	-	-
200	0821401223	0821401233	0821401243	0821401282	0821401261	0821401271
250	0821401224	0821401234	0821401244	0821401286	-	-
320	0821401225	0821401235	0821401245	0821401283	0821401262	0821401272
400	0821401226	0821401236	0821401246	0821401287	-	-
500	0821401227	0821401237	0821401247	0821401284	0821401263	0821401273
600	0821401228	0821401238	0821401249	0821401288	0821401264	0821401274
800	0821401229	0821401239	0821401474	0821401289	0821401265	0821401275
1000	0821401470	0821401472	0821401475	0821401290	0821401266	0821401276
1200	0821401471	0821401473	0821401476	0821401291	0821401267	0821401277

Inch dimensions rounded to the nearest whole number. For use with hybrid inch cylinders with metric piston rod thread

Technical data

Suitable piston Ø	32 mm	40 mm	50 mm	63 mm	80 mm	100 mm
Weight 0 mm stroke	1.3 kg	2.3 kg	3.7 kg	4.7 kg	8.8 kg	11.1 kg
+10 mm stroke	0.009 kg	0.016 kg	0.025 kg	0.025 kg	0.039 kg	0.039 kg

Technical information

Material	
Bearing housings	Aluminum, colorless anodized
Bearing type	Sintered bronze
Carrying plate	Aluminum, colorless anodized

Material	
Flexible coupling in carrying plate	Stainless steel
Guide rods	Hardened heat-treated steel, ground

Dimensions

Ø 32 ... 100 mm

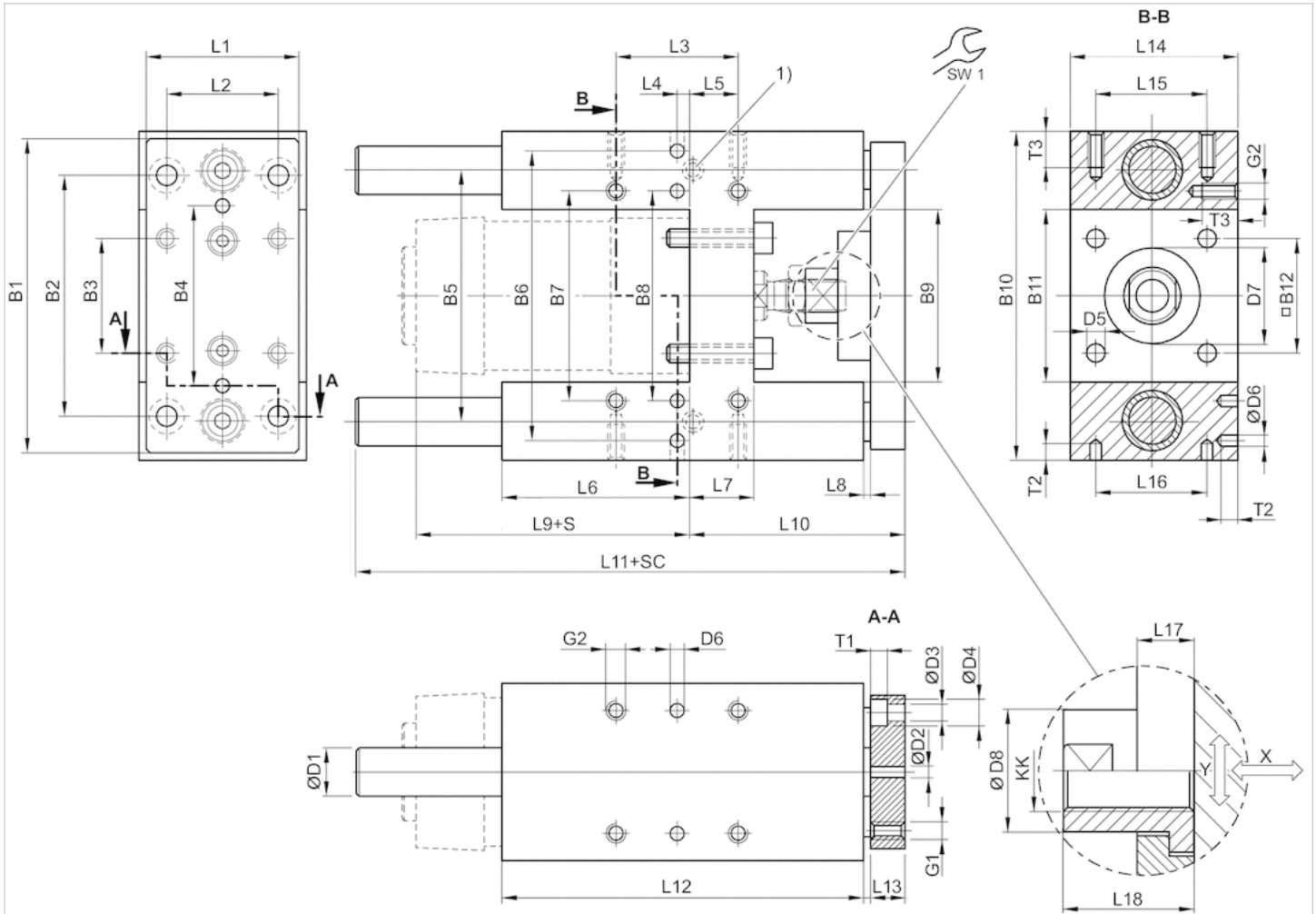

- 1) Lube nipple
- S = stroke
- SC = cylinder stroke
- X = max. play (axial)
- Y = min. play (radial)

Dimensions

Piston Ø	B1	B2	B3	B4	B5	B6	B7	B8	B9	B10	B11	B12	D1	D2 H7	D3	D4	D5	D6 H7
32 mm	90	78	32.5	50	74	81	61	61	50.2	97	50.2	32.5	12	6	6.6	11	6.6	6
40 mm	110	84	38	54	87	99	69	69	58.2	115	58.2	38	16	6	6.6	11	6.6	6
50 mm	130	100	46.5	72	104	119	85	85	70.2	137	70.2	46.5	20	6	9	15	9	6
63 mm	145	105	56.5	82	119	132	100	100	85.2	152	85.2	56.5	20	6	9	15	9	6
80 mm	180	130	72	106	148	166	130	130	105.4	189	105.4	72	25	6	11	18	11	6
100 mm	200	150	89	131	172	190	150	150	130.4	213	130.4	89	25	6	11	18	11	6

Piston Ø	D7 M8	D8	G1	G2	KK	L1	L2	L3	L4	L5	L6	L7	L8	L9	L10	L11	L12
32 mm	30	14.5	M6	M6	M10x1,25	45	32.5	32.5	12	4.25	76	17	3	94	64	177.5	125
40 mm	35	18	M6	M6	M12x1,25	54	38	38	8	11	81	21	3	105	74	192.5	140
50 mm	40	24	M8	M8	M16x1,5	63	46.5	46.5	4.5	18.75	79	26	3	106	89	205	150
63 mm	45	24	M8	M8	M16x1,5	80	56.5	56.5	13	15.25	111	26	3	121	89	237	182
80 mm	45	30	M10	M10	M20x1,5	100	72	72	15	21	128	34	3	128	110	280	215
100 mm	55	30	M10	M10	M20x1,5	120	89	89	20	24.5	128	39	3	138	115	280	220

Piston Ø	L13	L14	L15	L16	L17	L18	T1	T2	T3	SW1
32 mm	12	50	32.5	32.5	6	17	6.5	10	15	13
40 mm	12	58	38	38	14	22	6.5	10	15	15
50 mm	15	70	46.5	46.5	14	26	9	10	16	22
63 mm	15	85	56.5	56.5	14	26	9	10	16	22
80 mm	20	105	72	72	14	32	11	10	20	27
100 mm	20	130	89	89	14	32	11	10	20	27

Diagrams

Useful load

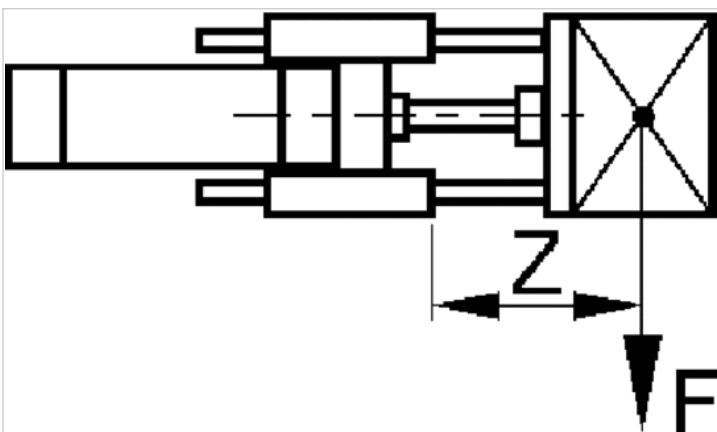

F = Useful load, Z = Projection

Useful load

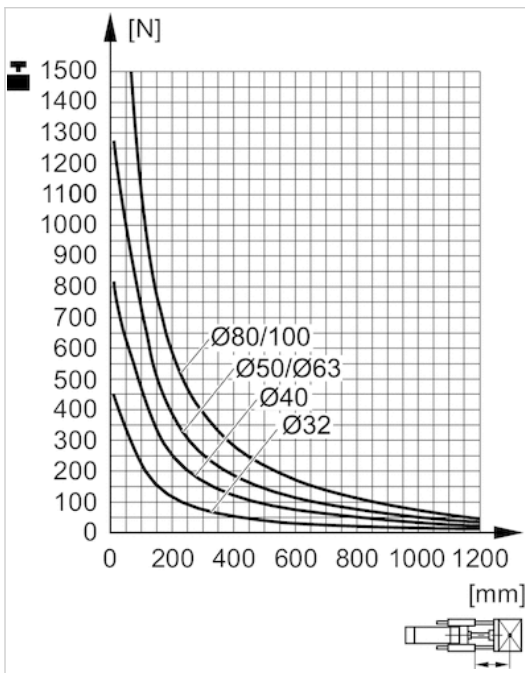

F = Useful load, Z = Projection

Bending due to own load

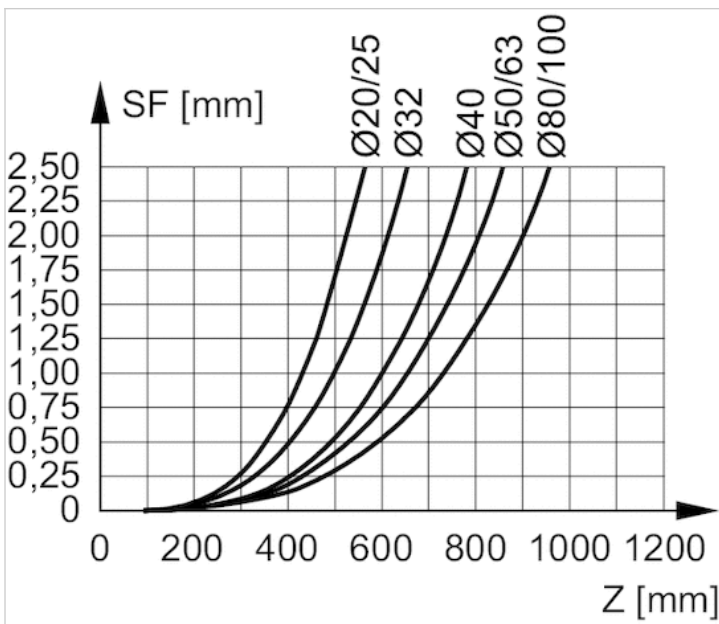

F = useful load (at the load center), SF = bending, Z = projection

Bending due to 10 N load

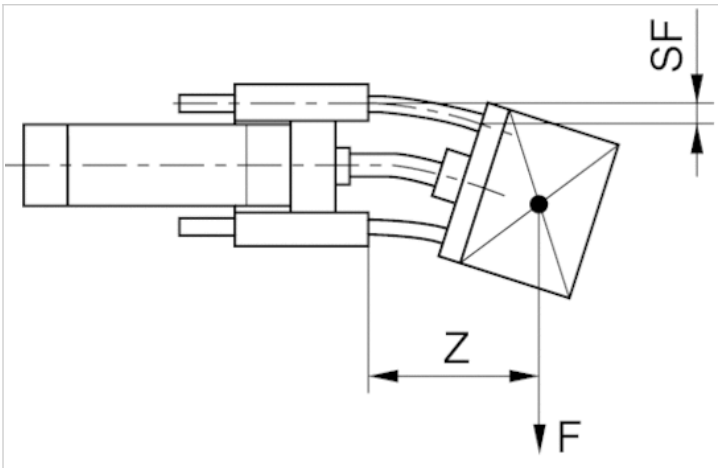

F = useful load (at the load center), SF = bending, Z = projection

Bending due to 10 N load

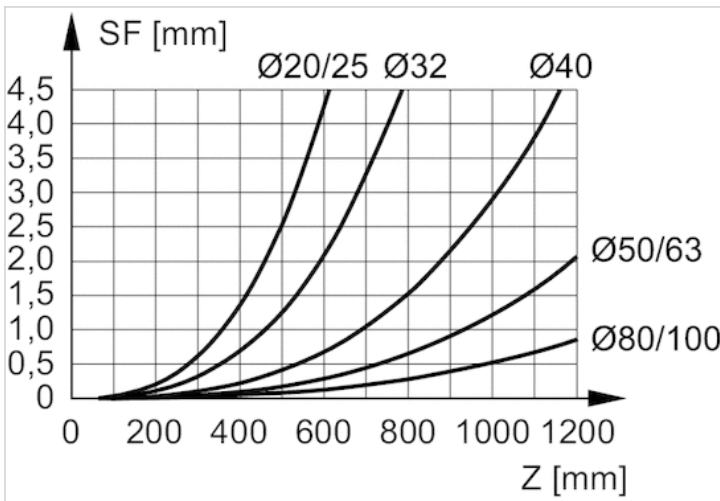

F = useful load (at the load center), SF = bending, Z = projection

Guide unit GH2, Series CG1

- Ø 32-100 mm
- Linear ball bearing
- For standard cylinders ISO 15552



Bearing type

Linear ball bearing

Ambient temperature min./max.

-20 ... 80 °C

Technical data

Suitable piston Ø	32 mm	40 mm	50 mm	63 mm	80 mm	100 mm
Stroke 50	0821401320	0821401330	0821401340	0821401380	-	-
100	0821401321	0821401331	0821401341	0821401381	0821401360	0821401370
200	0821401322	0821401332	0821401342	0821401382	0821401361	0821401371
320	0821401323	0821401333	0821401343	0821401383	0821401362	0821401372
500	0821401324	0821401334	0821401344	0821401384	0821401363	0821401373
600	0821401325	0821401335	0821401345	0821401385	0821401364	0821401374
800	0821401326	0821401336	0821401346	0821401386	0821401365	0821401375
1000	0821401327	0821401337	0821401347	0821401387	0821401366	0821401376
1200	0821401328	0821401338	0821401348	0821401388	0821401367	0821401377

For use with hybrid inch cylinders with metric piston rod thread

Technical data

Suitable piston Ø	32 mm	40 mm	50 mm	63 mm	80 mm	100 mm
Weight 0 mm stroke	1.3 kg	2.3 kg	3.7 kg	4.7 kg	8.8 kg	11.1 kg
+10 mm stroke	0.009 kg	0.016 kg	0.025 kg	0.025 kg	0.039 kg	0.039 kg

Technical information

Material	
Bearing housings	Aluminum, colorless anodized
Bearing type	Steel
Carrying plate	Aluminum, colorless anodized
Flexible coupling in carrying plate	Stainless steel
Guide rods	Hardened heat-treated steel

Dimensions

Ø 32 ... 100 mm

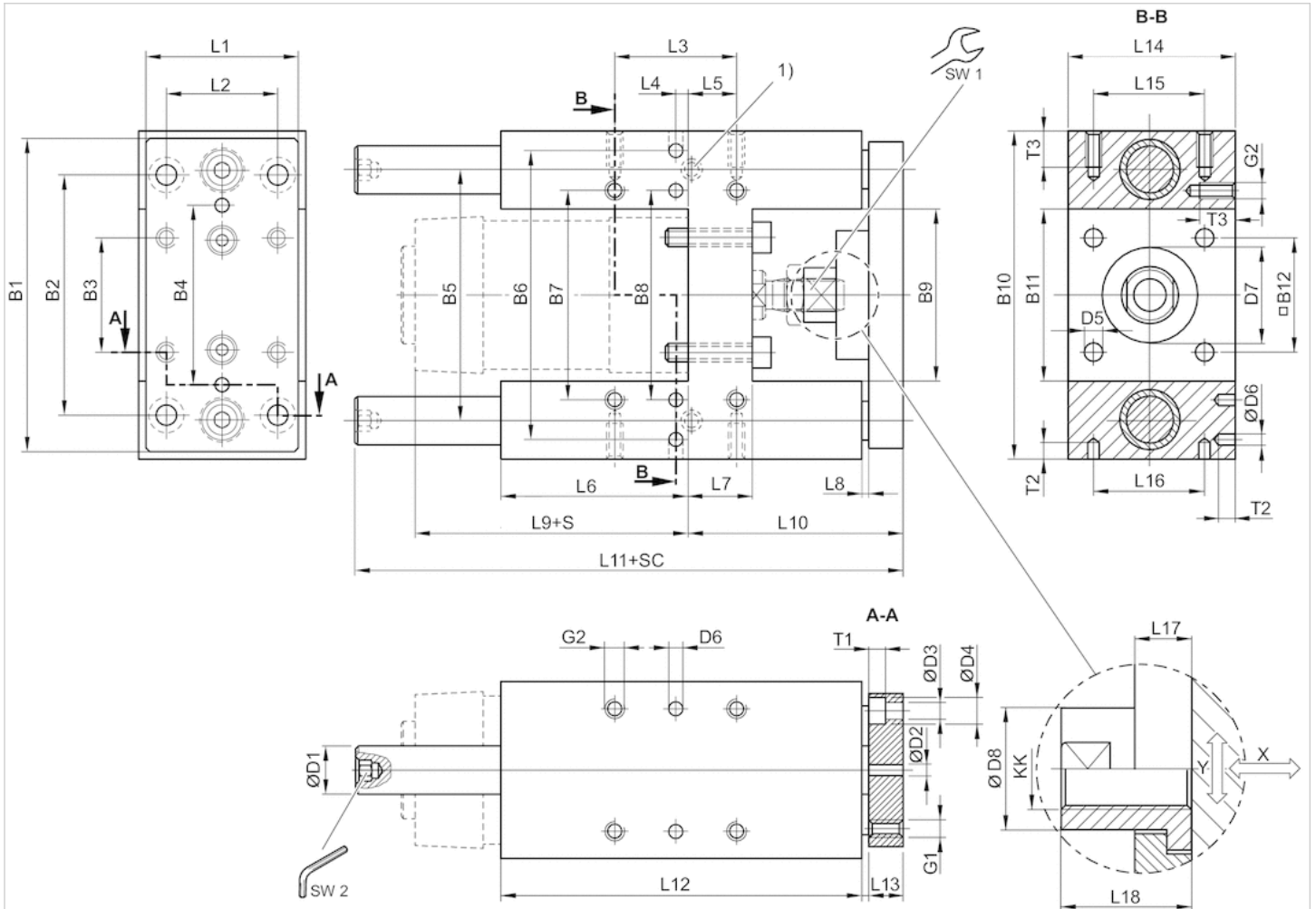

1) Lube nipple

S = stroke

SC = cylinder stroke

X = max. play (axial)

Y = min. play (radial)

Hexagon in guide rod

Dimensions

Piston Ø	B1	B2	B3	B4	B5	B6	B7	B8	B9	B10	B11	B12	D1	D2 H7	D3	D4	D5	D6 H7
32 mm	90	78	32.5	50	74	81	61	61	50.2	97	50.2	32.5	12	6	6.6	11	6.6	6
40 mm	110	84	38	54	87	99	69	69	58.2	115	58.2	38	16	6	6.6	11	6.6	6
50 mm	130	100	46.5	72	104	119	85	85	70.2	137	70.2	46.5	20	6	9	15	9	6
63 mm	145	105	56.5	82	119	132	100	100	85.2	152	85.2	56.5	20	6	9	15	9	6
80 mm	180	130	72	106	148	166	130	130	105.4	189	105.4	72	25	6	11	18	11	6
100 mm	200	150	89	131	172	190	150	150	130.4	213	130.4	89	25	6	11	18	11	6

Piston Ø	D7 M8	D8	G1	G2	KK	L1	L2	L3	L4	L5	L6	L7	L8	L9	L10	L11	L12
32 mm	30	14.5	M6	M6	M10x1,25	45	32.5	32.5	12	4.25	76	17	3	94	64	177.5	125
40 mm	35	18	M6	M6	M12x1,25	54	38	38	8	11	81	21	3	105	74	192.5	140

Piston Ø	D7 M8	D8	G1	G2	KK	L1	L2	L3	L4	L5	L6	L7	L8	L9	L10	L11	L12
50 mm	40	24	M8	M8	M16x1,5	63	46.5	46.5	4.5	18.75	79	26	3	106	89	237	150
63 mm	45	24	M8	M8	M16x1,5	80	56.5	56.5	13	15.25	111	26	3	121	89	237	182
80 mm	45	30	M10	M10	M20x1,5	100	72	72	15	21	128	34	3	128	110	280	215
100 mm	55	30	M10	M10	M20x1,5	120	89	89	20	24.5	128	39	3	138	115	280	220

Piston Ø	L13	L14	L15	L16	L17	L18	T1	T2	T3	SW1	SW2
32 mm	12	50	32.5	32.5	6	17	6.5	10	15	13	5
40 mm	12	58	38	38	14	22	6.5	10	15	15	6
50 mm	15	70	46.5	46.5	14	26	9	10	16	22	6
63 mm	15	85	56.5	56.5	14	26	9	10	16	22	6
80 mm	20	105	72	72	14	32	11	10	20	27	8
100 mm	20	130	89	89	14	32	11	10	20	27	8

Diagrams

Useful load

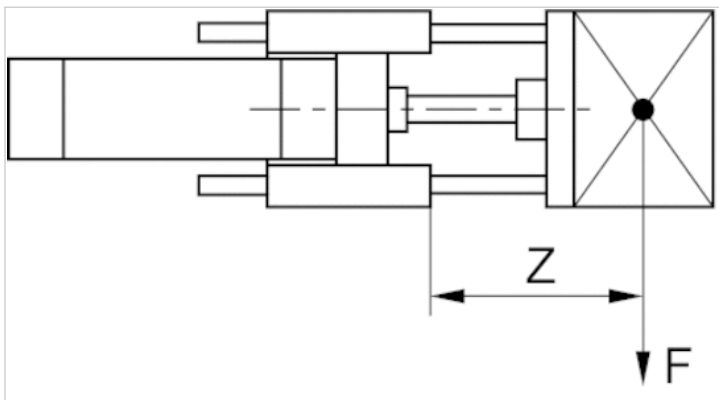

F = Useful load, Z = Projection

Useful load

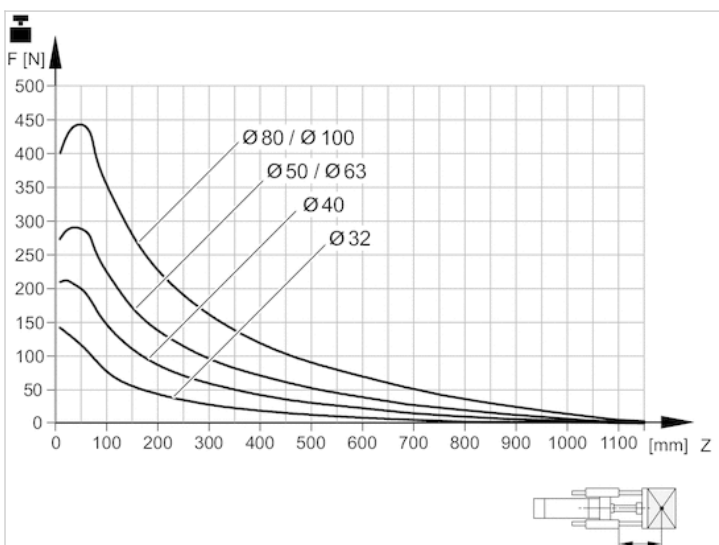

Service life 2×10^6 m

F = Useful load, Z = Projection

Useful load

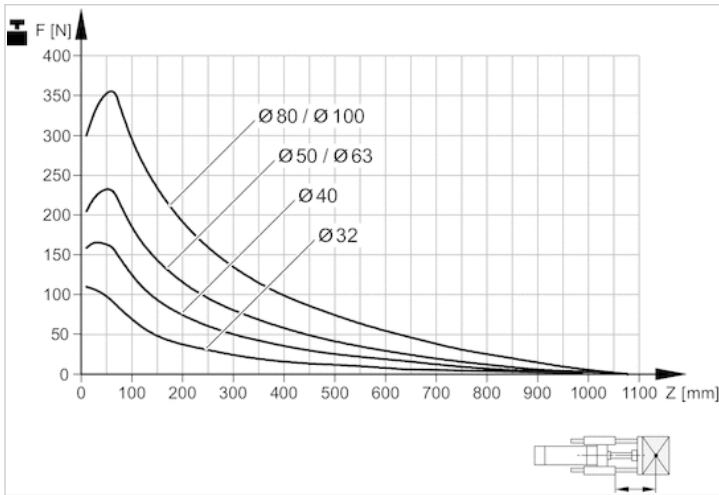

Service life 5×10^6 m

F = Useful load, Z = Projection

Reduction of useful load for short-stroke

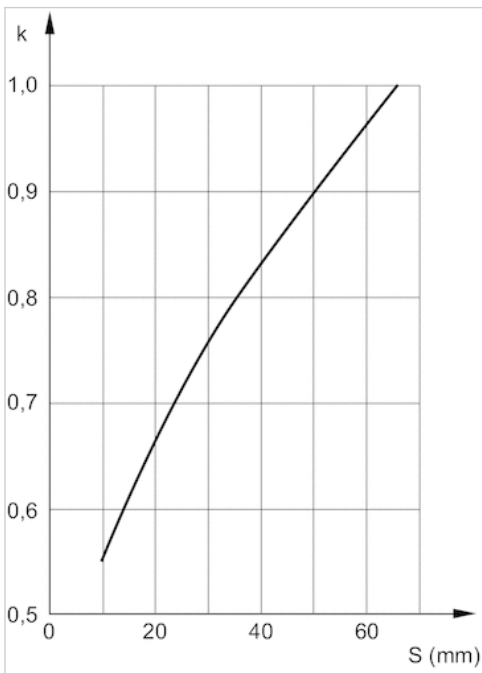

S = stroke

k=correction factor: normal=1, shock loaded=2

With a short stroke, the useful load figures determined from the diagram must be multiplied by the correction factor k. These short-stroke adjustments are already included in the load diagram for a displacement of up to 60 mm.

Bending due to own load

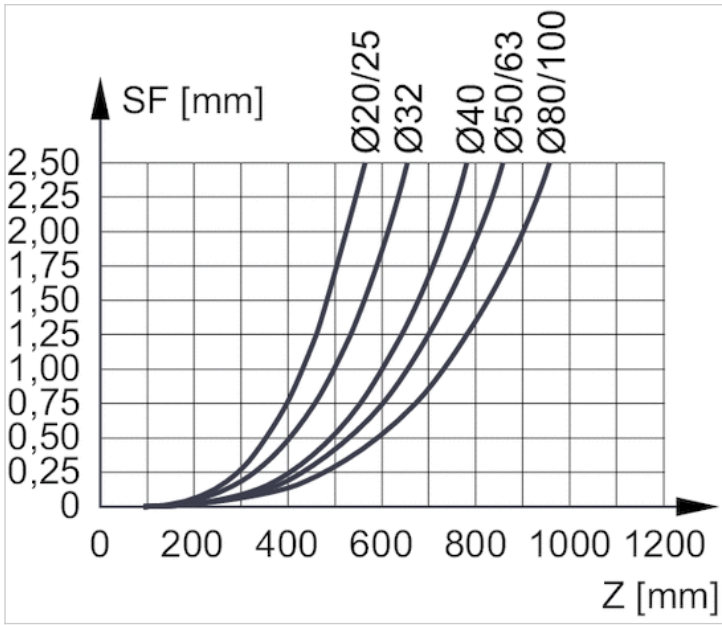

F = useful load (at the load center), SF = bending, Z = projection

Bending due to 10 N load

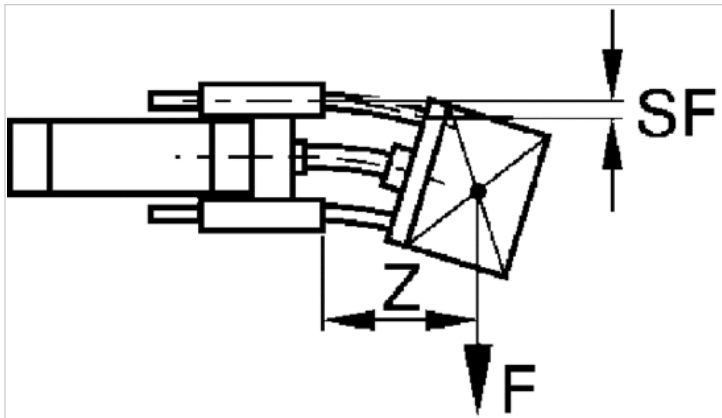

F = useful load (at the load center), SF = bending, Z = projection

Bending due to 10 N load

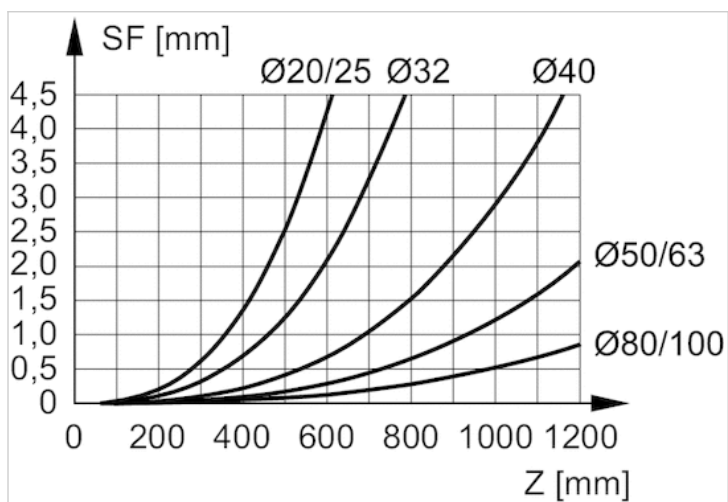

F = useful load (at the load center), SF = bending, Z = projection

Compensating coupling GU3 form A, series CG1



Technical data

Part No.	Suitable piston rod thread	Fig.
R413000277	M8	Fig. 1
R413000278	M10x1,25	Fig. 1
R413000279	M10x1,25	Fig. 2
R413000282	M20x1,5	Fig. 2

Scope of delivery: flexible coupling incl. mounting screws

Technical information

Material	
	Stainless steel
	Steel

Dimensions

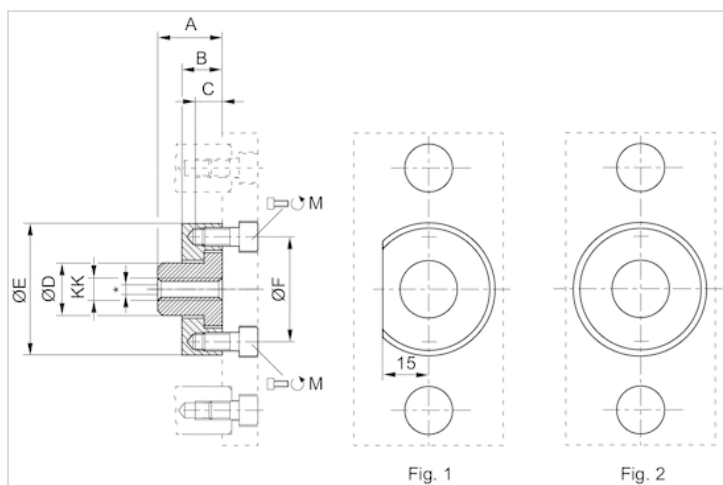

* Radial joint from 1,0 ... 2,5 mm

Dimensions

Part No.	KK	Ø	M	A	B	C	ØD	ØE	ØF	Fig.
R413000277	M8	20	2x M6x12	22	14	8	18	45	36	Fig. 1
R413000278	M10x1,25	25	2x M6x12	22	14	8	18	45	36	Fig. 1
R413000279	M10x1,25	32	2x M6x12	22	14	8	18	45	36	Fig. 2
R413000282	M20x1,5	80/100	4x M6x14	32	14	9.5	30	60	51	Fig. 2

Compensating coupling GU3 form B, series CG1



Technical data

Part No.	Suitable piston rod thread
R413000283	M8
R413000284	M10x1,25
R413000285	M20x1,5

Scope of delivery: flexible coupling incl. mounting screws

Technical information

Material	
	Stainless steel
	Steel

Dimensions

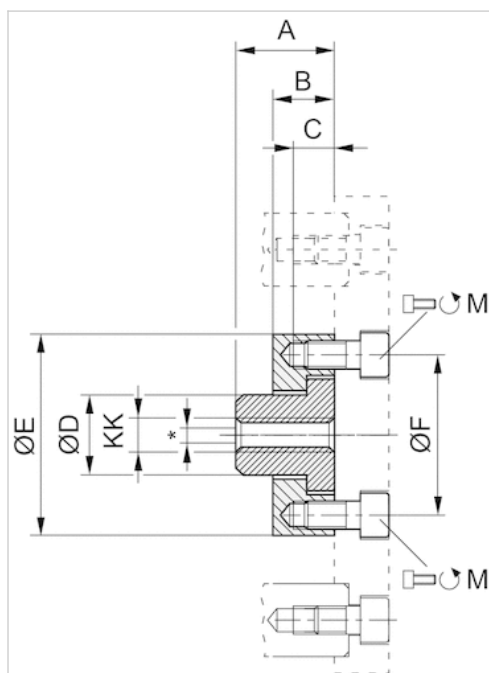

* Radial joint from 1,5 ... 1,8 mm

Dimensions

Part No.	KK	Ø	M	A	B	C	D	ØE	ØF
R413000283	M8	20	2x M5x12	22	6	6	14.5	SW 30	26
R413000284	M10x1,25	25/32	2x M5x12	17	6	6	14.5	SW 30	26
R413000285	M20x1,5	80/100	4x M6x20	32	14	9.5	30	60	51

Compensating coupling GU3 form C, series CG1



Technical data

Part No.	Suitable piston rod thread
R413000276	M6
R413000280	M12x1,25
R413000281	M16x1,5

Scope of delivery: flexible coupling incl. mounting screws

Technical information

Material	
	Stainless steel
	Steel

Dimensions

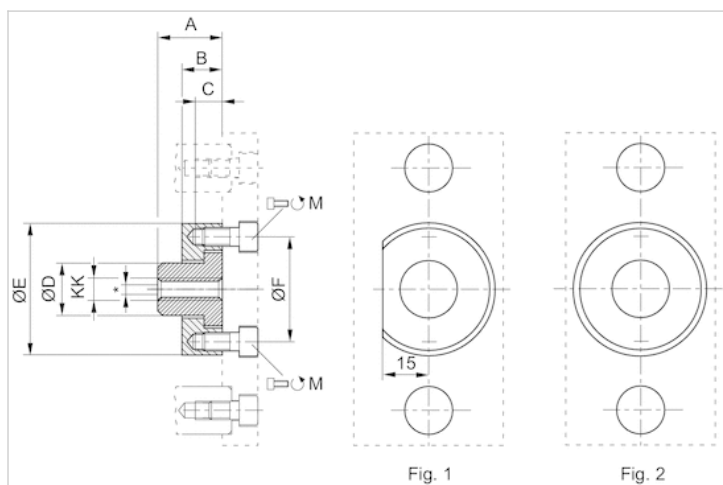

* Radial joint from 1,0 ... 2,5 mm

Dimensions

Part No.	KK	Ø	M	A	B	C	D	ØE	ØF
R413000276	M6	12/16	2x M4x10	18	7	7	10	22	15
R413000280	M12x1,25	40	2x M6x12	22	14	8	18	45	36
R413000281	M16x1,5	50/63	4x M6x14	26	14	8	24	54	45

Efficient pneumatic solutions, our program: cylinders and drives, valves and valve systems, air supply management



Visit us: [Emerson.com/Aventics](https://www.emerson.com/Aventics)

Your local contact: [Emerson.com/contactus](https://www.emerson.com/contactus)



Emerson.com



[Facebook.com/EmersonAutomationSolutions](https://www.facebook.com/EmersonAutomationSolutions)



[LinkedIn.com/company/Emerson-Automation-Solutions](https://www.linkedin.com/company/Emerson-Automation-Solutions)



[Twitter.com/EMR_Automation](https://twitter.com/EMR_Automation)

An example configuration is depicted on the title page. The delivered product may thus vary from that in the illustration. Subject to change. This Document, as well as the data, specifications and other information set forth in it, are the exclusive property of AVENTICS GmbH. It may not be reproduced or given to third parties without its consent. Only use the AVENTICS products shown in industrial applications. Read the product documentation completely and carefully before using the product. Observe the applicable regulations and laws of the respective country. When integrating the product into applications, note the system manufacturer's specifications for safe use of the product. The data specified only serve to describe the product. No statements concerning a certain condition or suitability for a certain application can be derived from our information. The information given does not release the user from the obligation of own judgment and verification. It must be remembered that the products are subject to a natural process of wear and aging.

The Emerson logo is a trademark and service mark of Emerson Electric Co. Brand logotype are registered trademarks of one of the Emerson family of companies. All other marks are the property of their respective owners. © 2017 Emerson Electric Co. All rights reserved.
2019-03



CONSIDER IT SOLVED™