



SAFETY.

A New Standard for Your Safety

www.autonics.com

Autonics

Distributed by Valin Corporation | www.valin.com | (800) 774-5630 | customerservice@valin.com

Contents

Light the Way to Your Safety

Safety Light Curtains

Standard Type	SFL Series	8
High Performance Type	SFLA Series	

Opening a New Era of Safety

Safety Door Switches

Door Switches	SFD Series	28
Door Lock Switches	SFDL Series	34
Flat Type Door Lock Switches	SFDL2 Series	42
Non-Contact Door Switches	SFN Series	50

The Key to Your Safety

Safety Switches

Emergency Stop Button Switches	SF2ER Series	56
Grip Type Enabling Switches	SFEN Series	62
Key Selector Switches	SF2KR Series	68

Take Control of Your Safety

Safety Controllers

Controllers	SFC/SFC-R Series	74
-------------	------------------	----

Your Safety is Our Top Priority

“Safety” is becoming an essential part in industrial automation, and the two parts are very closely associated. New safety standards have become mandatory in many industrial fields, to protect personnel from injury in potentially dangerous areas or situations. Automation technology is changing rapidly, with increased chance of injury from dangerous machinery.

Safety system can be applied in almost all industrial fields where people and machines must co-exist. By implementing safety systems, companies can ensure safe environments for workers, reduce costs from health risks and increase work efficiency. Safety system is no longer a choice to make, it has become an essential requirement.

Autonics is proud to introduce various safety products to ensure safety in industrial sites. With automation technology and expertise which we have built for over 40 years, we now present new safety products that will protect you and your equipment.

Autonics safety solution promises to keep you safe and raise workplace efficiency with stable, reliable, flexible, and practical safety products and systems.

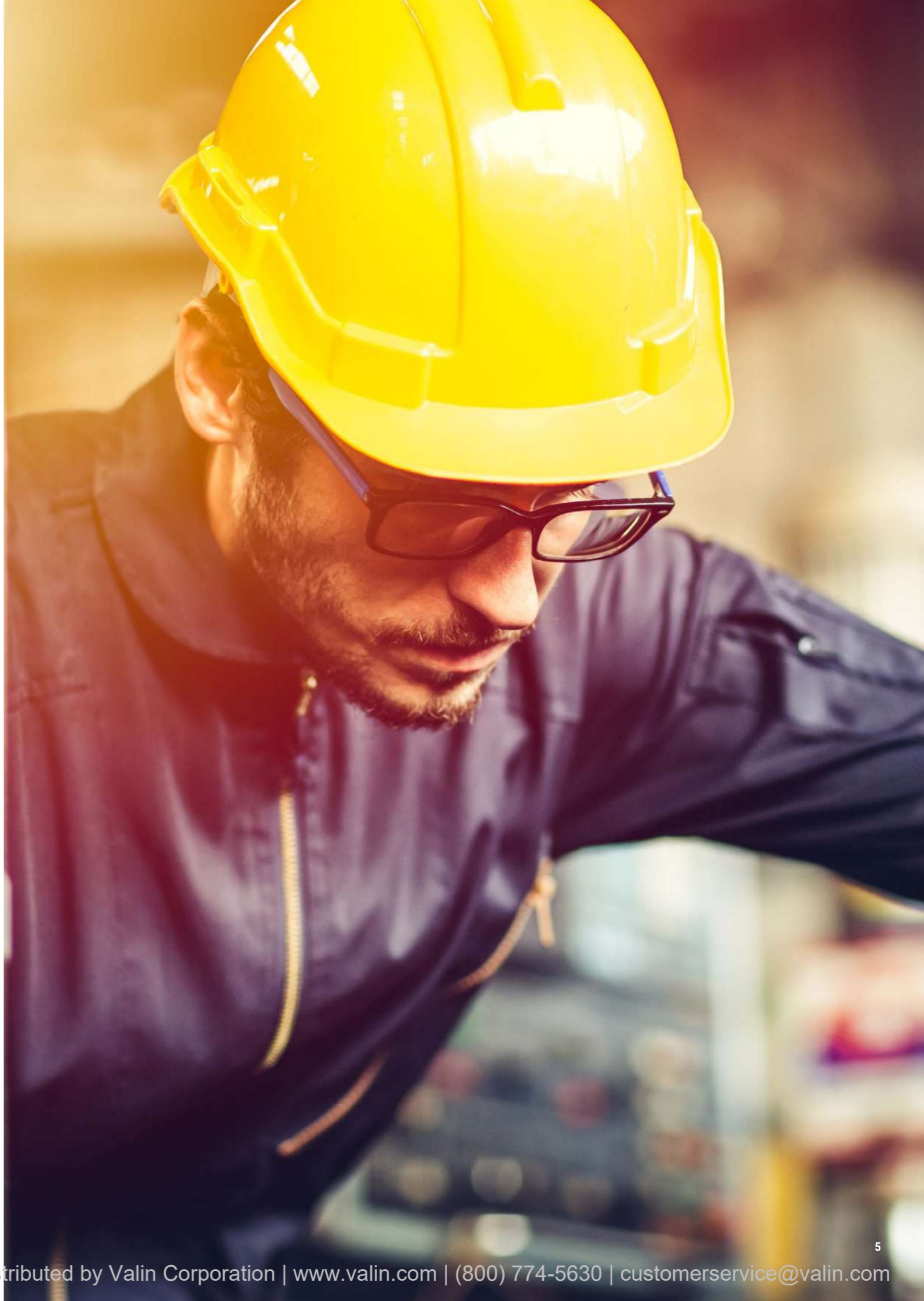

Stay Safe Anywhere with Various Autonics Safety Products and Solutions

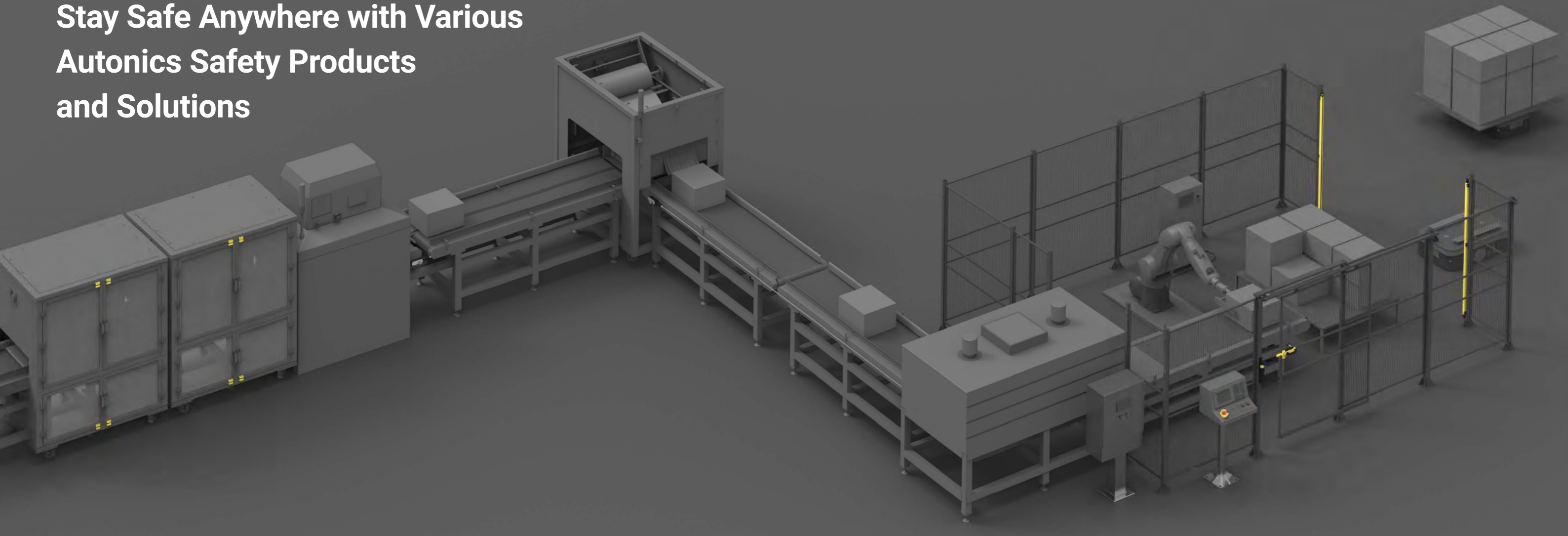

Safety is a top concern in industries where personnel and machines must work together. As a partner to keep you and your machines safe, Autonics offers various safety technology and solutions.

Autonics safety products feature high flexibility and practicality, with various product options and functions that can be applied in various different environments. Our products are developed to meet customer needs and demands in the industry and also to increase workplace efficiency.

With Autonics safety solutions, you can minimize various risks and prevent accidents by analyzing environmental and operational settings. Ensure peace of mind at your operation sites by choosing Autonics safety products. We will keep you safe.



Safety Light Curtains

- Standard Type
SFL Series
- High Performance Type
SFLA Series



Safety Door Switches

- Door Switches
SFD Series
- Door Lock Switches
SFDL Series
- Flat Type Door Lock Switches
SFDL2 Series
- Non-Contact Door Switches
SFN Series



Safety Switches

- Emergency Stop Button Switches
SF2ER Series
- Grip Type Enabling Switches
SFEN Series
- Key Selector Switches
SF2KR Series



Safety Controllers

- Standard Unit
SFC
- High Performance Unit
SFC-A
- Non-Contact Door Switch Unit
SFC-N
- Expansion Relay Unit
SFC-ER
- Relay Unit
SFC-R

Light the Way to Your Safety

Safety Light Curtains

SFL/SFLA Series

Safety light curtains are installed in potentially dangerous or hazardous areas or machines to safeguard personnel from injury. Operation of potentially dangerous machines are turned off when an object or person is detected between the emitter and receiver. The light curtains feature proven technology from Autonics area sensors and mapping sensors. The light curtains are built to meet international safety standards and regulations. Various detection models and safety functions are available to protect your safety diverse applications.

Safety Standards

IEC/EN 61508 (SIL 3)

IEC/EN 62061 (SIL CL 3)

EN/IEC 61496-1/2 (Type 4, A.O.P.D., E.S.P.E.)

ISO 13849-1/2 (Cat. 4, PL e)

Certifications

CE TÜV NORD cUL US LISTED S KCS (INDUSTRIAL ROBOT PROTECTION DEVICE)



Various Models Available for Flexible Applications

The SFL/SFLA series safety light curtains are available in various models for flexible application. The light curtains are available in various product heights, beam pitch size (9 mm/15 mm/25 mm) for installation in diverse environments. The light curtains can be expanded to 4 sets and 400 beams for application in larger scale industrial environments.

1. Various Detection Type Models

Finger detection, hand detection, hand-body detection models are available for application in diverse user environments.

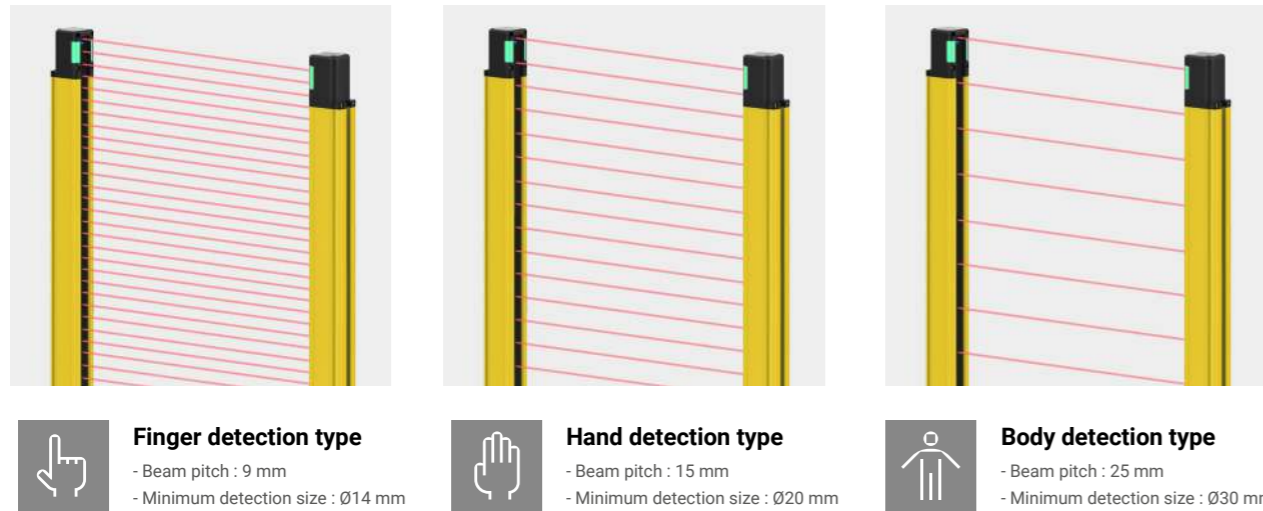

SFL Series (Standard Type)

	Finger	Hand	Body
Sensing distance (Long mode)	0.2 to 10 m	0.2 to 15 m	0.2 to 15 m
Detection capability	14 mm	20 mm	30 mm
Optical axis pitch	9 mm	15 mm	25 mm
Number of beams	15 to 111 ea	12 to 68 ea	42 to 75 ea
Protection height	144 to 1,008 mm	183 to 1,023 mm	1,043 to 1,868 mm

SFLA Series (High Performance Type)

	Finger	Hand	Body
Sensing distance (Long mode)	0.2 to 10 m	0.2 to 15 m	0.2 to 15 m
Detection capability	14 mm	20 mm	30 mm
Optical axis pitch	9 mm	15 mm	25 mm
Number of beams	15 to 199 ea	12 to 124 ea	9 to 75 ea
Protection height	144 to 1,800 mm	183 to 1,863 mm	218 to 1,868 mm

2. Various Protection Height

Various models are available by protection height (144 mm to 1,868 mm), offering options for diverse equipment sizes

1,868 mm

144 mm

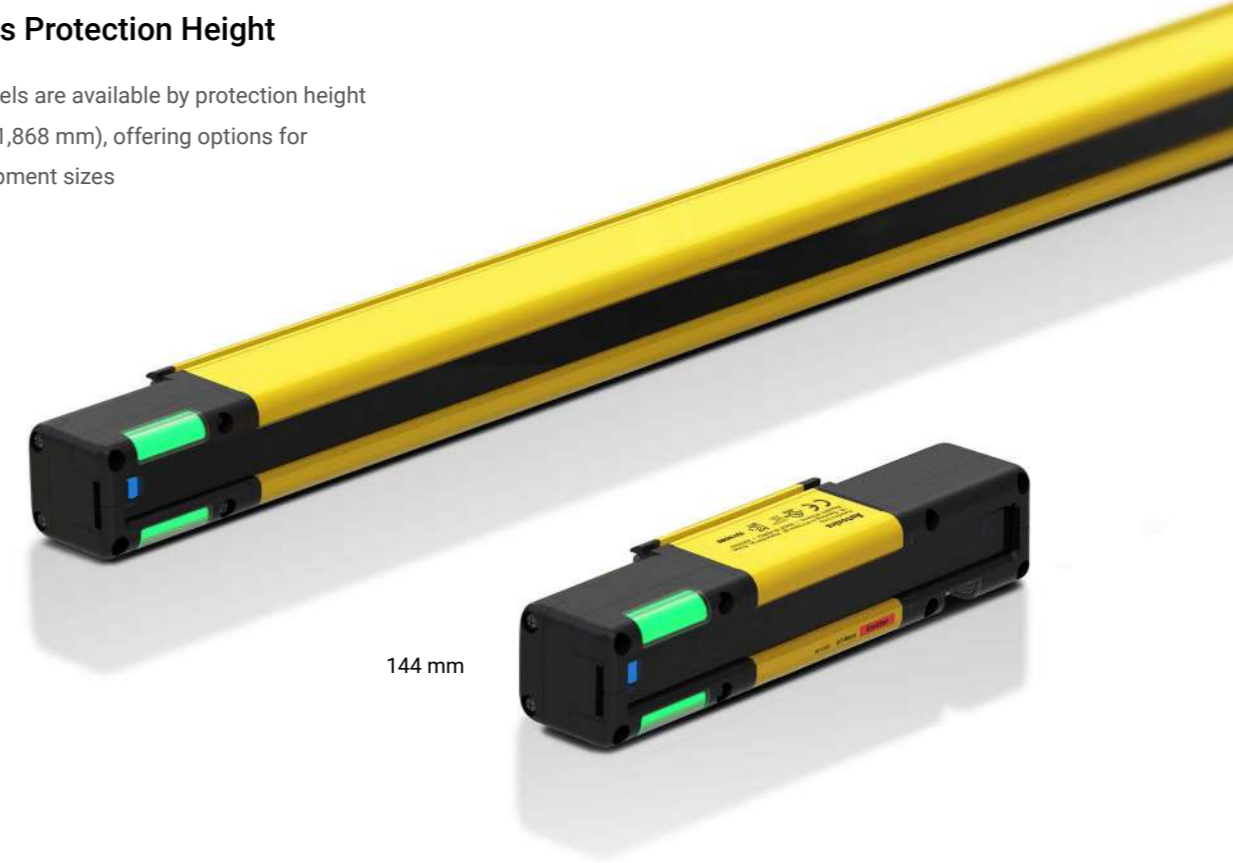

3. Long Sensing Distance

Long sensing distance (15 m) allows wider area of detection. The sensors can be set to short/long mode depending on user needs.

- Short Mode: 0.2 to 5 m / 0.2 to 8 m
- Long Mode: 0.2 to 10 m / 0.2 to 15 m

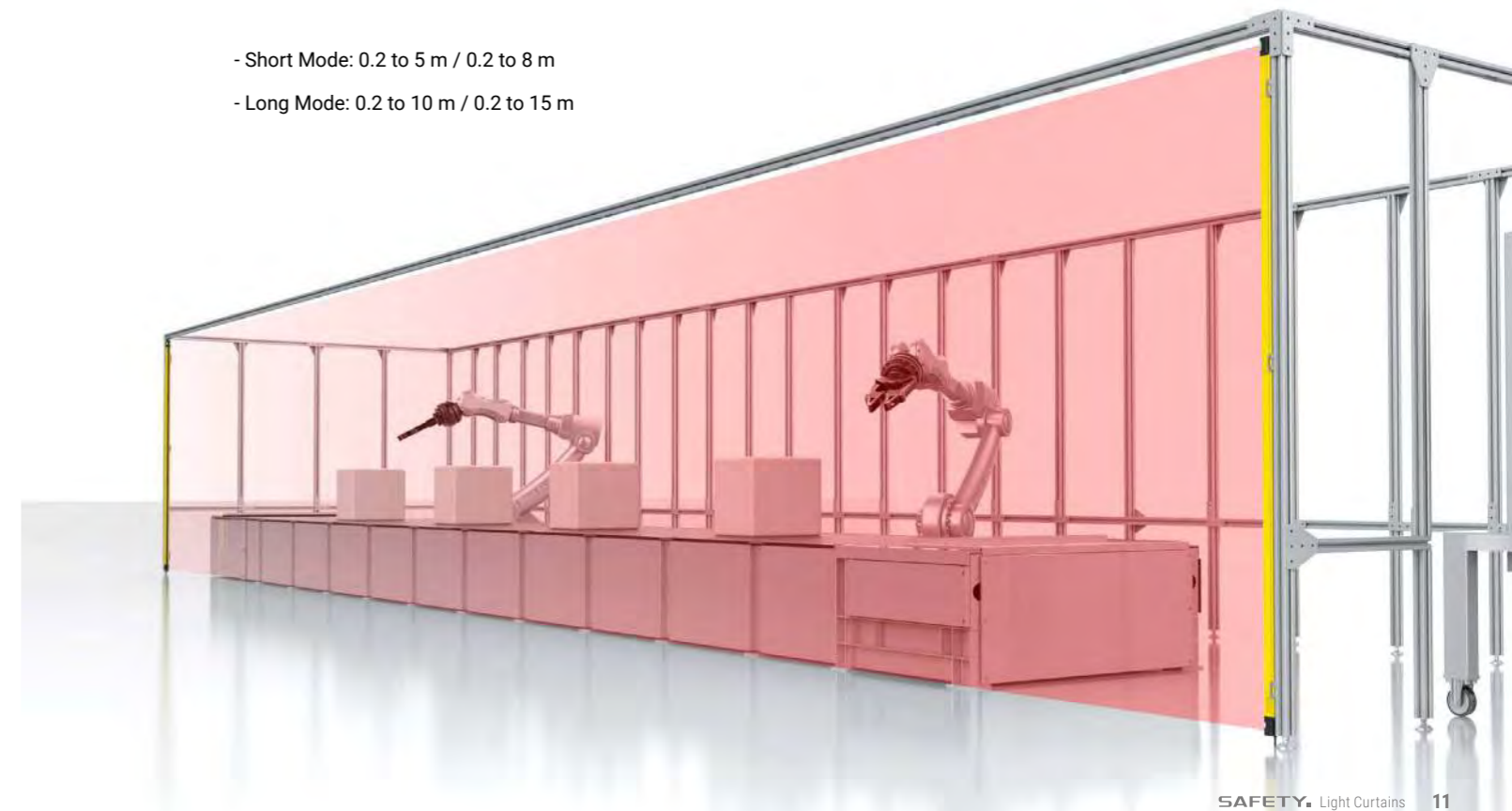

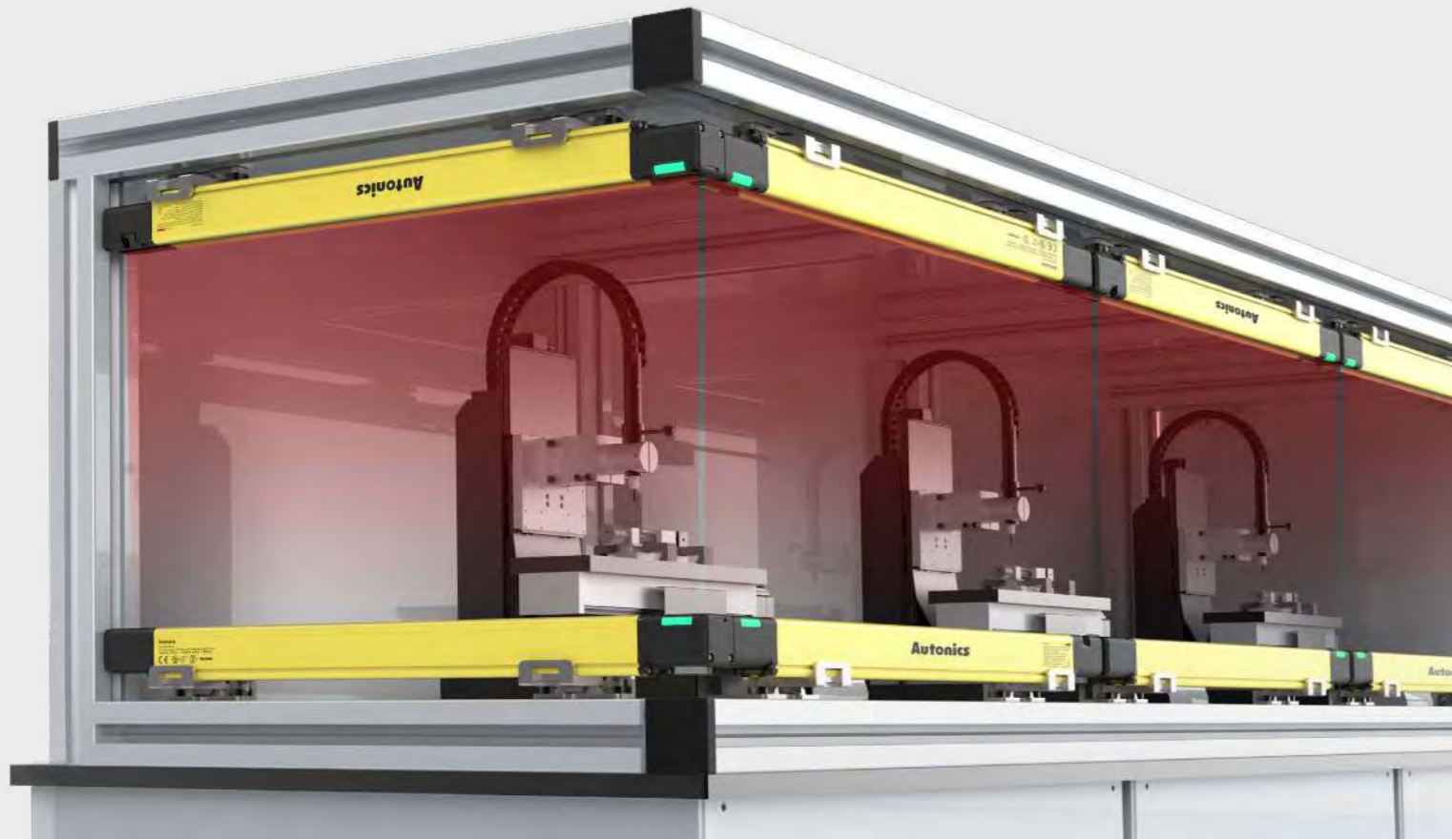

High Durability and Environmental Performance

The SFL/SFLA series is designed with hardened casing and screen protection for application in harsh conditions. The light curtains can be installed in environments with impact, dust, or moisture.

4. Expand up to 400 Beams

The SFLA series light curtains can be expanded up to 4 sets and 400 beams with serial expansion cables. Multiple light curtains can be controlled using a single connection line, offering easier wiring, installation, and design planning.

Also, the mutual interference protection ensures that there is no signal interference between the connected units. If an error is detected in a single unit, all connected units will enter into lockout state.

* SFL series: expand up to 3 sets and 300 beams

Serial Expansion Connection (SFLA Series)

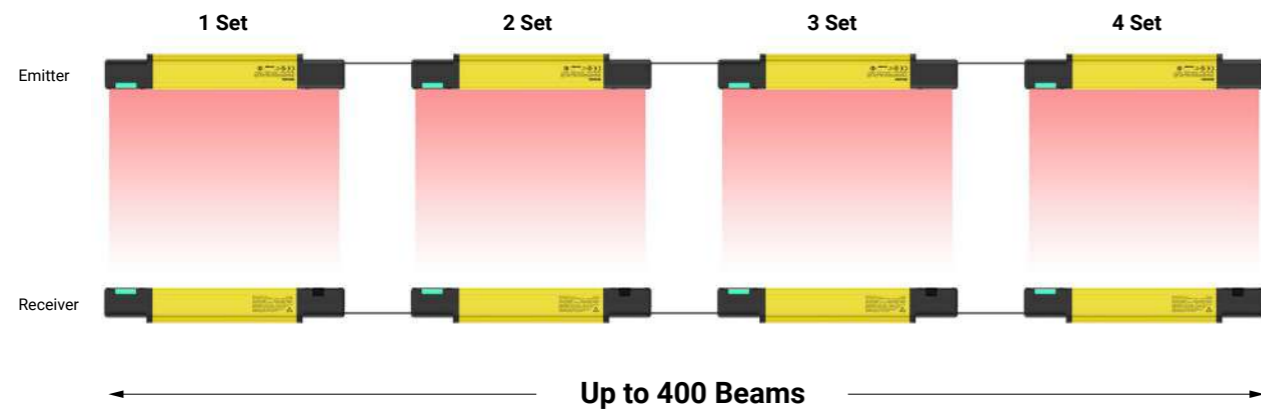

1. Robust Body Housing

The robust body housing allows stable operation in harsh conditions with sudden impact.

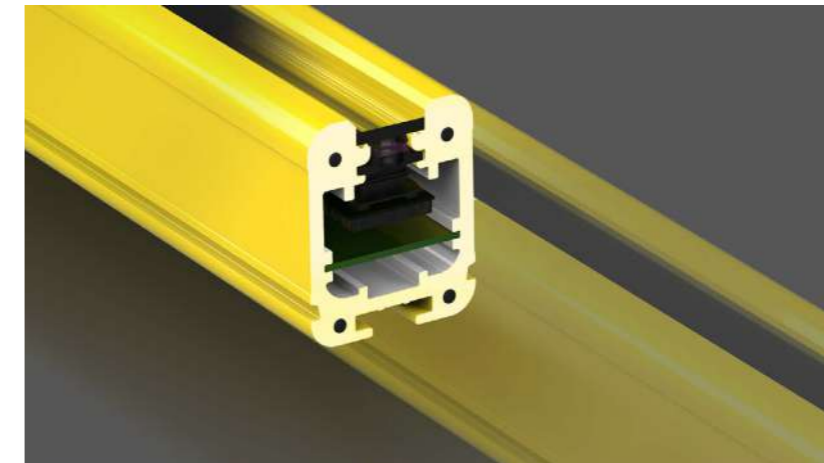

2. Window Screen Protection

The narrow window screen with protection minimizes the chance of impact to the sensing areas.



3. IP65/67 Protection Rating

IP65/67 protection structure allows stable and error-free operation even in wet or dusty environments.

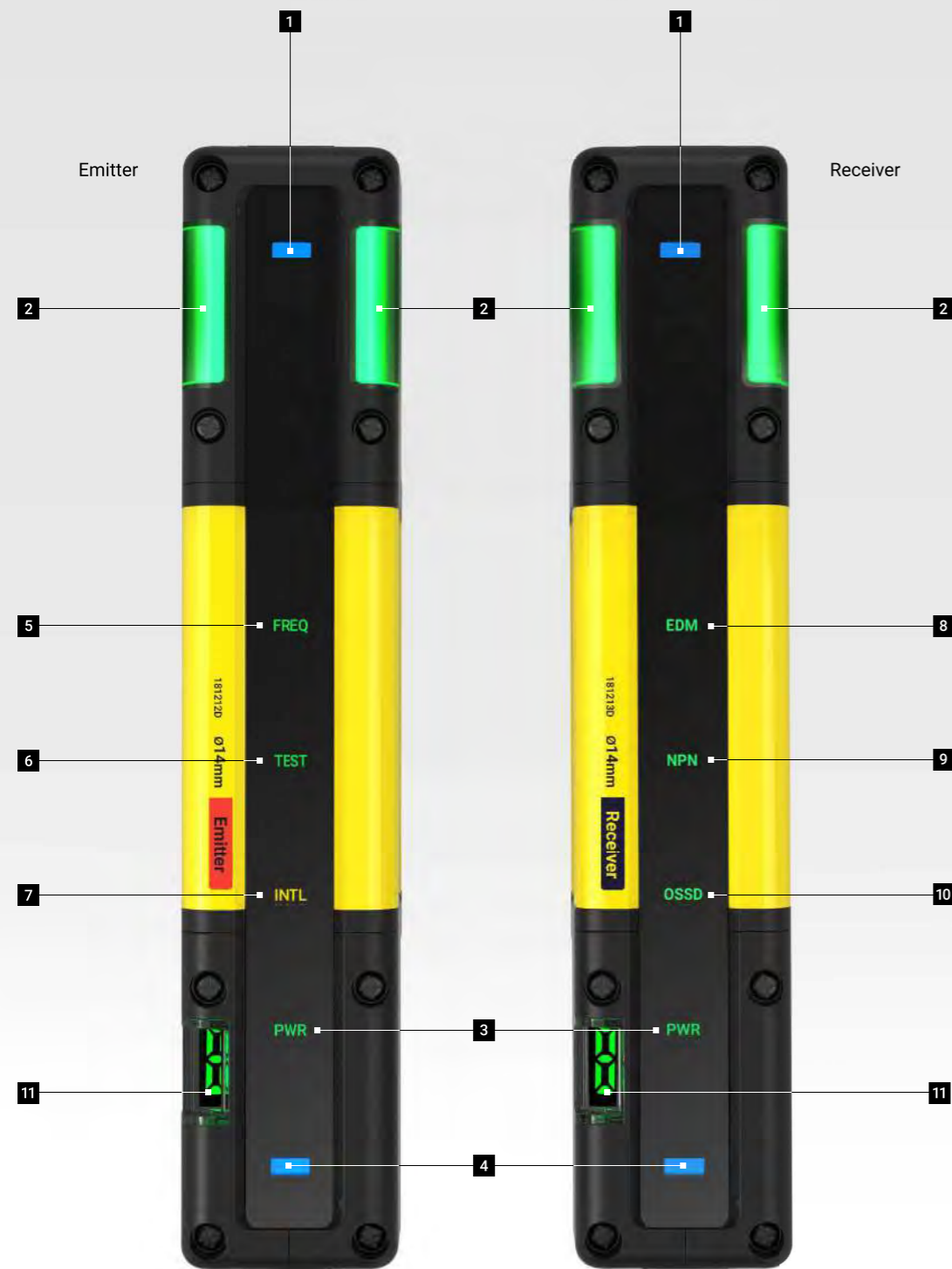

- 1 Top beam indicator** lights up top beam is received
- 2 Top control output indicator** lights up or flashes depending on control output
- 3 Power/lockout indicator** lights up when powered on
- 4 Bottom beam indicator** lights up when bottom beam is received
- 5 Frequency indicator** displays set frequency during mutual interference prevention
- 6 External test indicator** lights up when external test signal is applied
- 7 Interlock indicator** lights up when during interlock state
- 8 EDM indicator** lights up with EDM input
- 9 NPN/PNP indicator** lights up with NPN setting/turned off with PNP setting
- 10 Control output indicator** green light when output ON, red light when output OFF
- 11 Status display** indicates operation status

Easy Status Check with Indicators

The SFL/SFLA series is designed to provide a sense of safety to users. The large operation indicators offer minimal blind spots, and operators can easily check the status of the light curtains in real-time, ensuring safety of both personnel and machines.

1. Top Control Output Indicator

The top control output indicator shows various output status including output ON/OFF, muting/override status, lockout status etc. The indicator is located on the top corner of the unit, which make it highly visible from any angle.



2. Status Display

The 7-segment status display shows various operation status of the unit using alphabet or numbers. Users can check various status including error status, communication status, warning conditions, etc.



Status Display Description

Location	Operation	Display	Description	
Emitter / Receiver	PC connection (download)	P	Flashing	Flashes when downloading the setting information.
	Communication error	C	Flashing	Flashes when RS485 communication error occurs.
	Error condition	E	Flashing	Flashes when entering the lockout condition.
	Warning condition	W	Flashing	Flashes when in a warning condition.
Emitter	Default condition	0	ON	Displays when function is deactivated.
	Blanking	b	ON	Displays when the blanking function is activated.
	Muting	m	ON	Displays when in the muting state.
	Override	o	ON	Displays when in the override state.
	Reset-hold	H	ON	Displays when waiting for reset-hold input.
	Reduced resolution	r	ON	Displays when the reduced resolution function is activated.
Receiver	Light incident	0-9	ON	Displays the sensitivity level of beams with the lowest light incident (0 to 9).

3. Beam Indicator

The LED beam indicator turns blue when the beam is received normally, and turns off when the light is blocked. The LED turns red when ambient light is received. The indicator allows easy installation and setting, and also provides users with visual indication of errors.

1) Check Installation

The indicator can detect misalignment of emitter and receiver in real-time, allowing easier installation and setting.

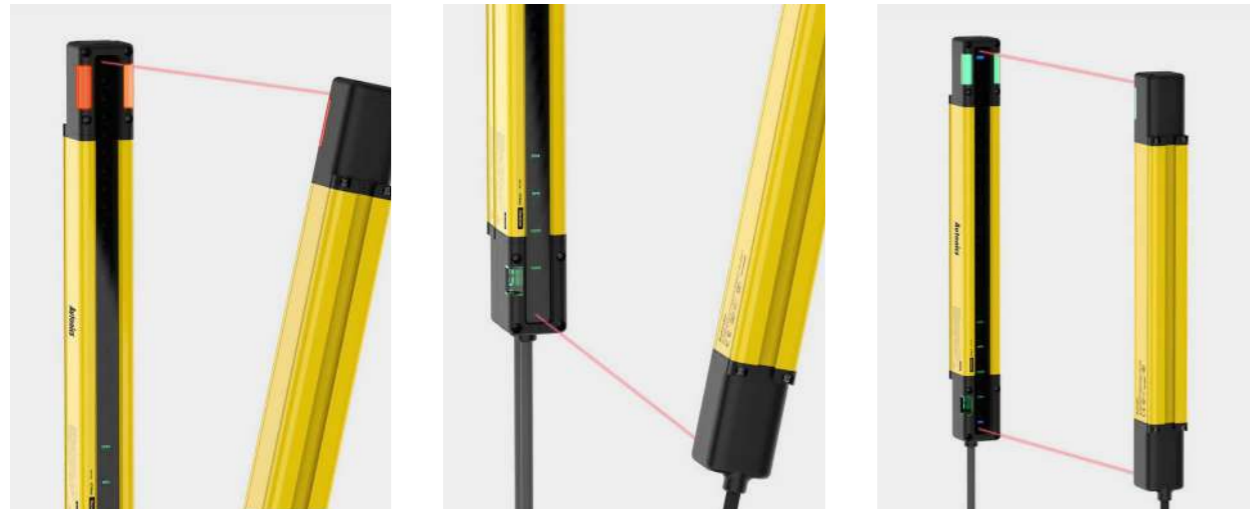

- 1 Align the top beam
- 2 Align the bottom beam
- 3 If the LED indicator turns blue, the beams have been aligned normally.

2) Check Light Sensitivity

The sensitivity reduction alarm is activated if the amount of light received changes due to vibration, heating, distortion, or other factors preventing problems in advance.

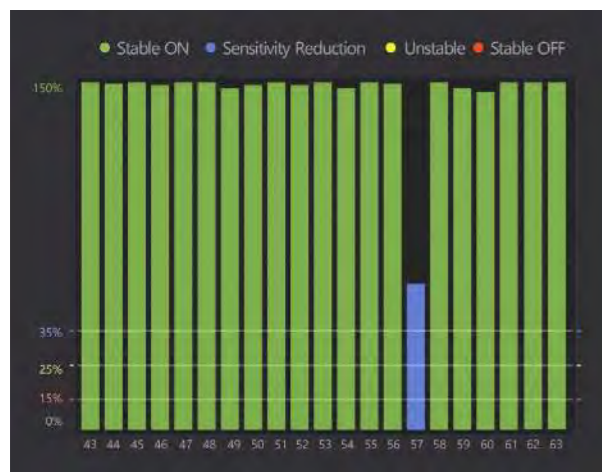

* Light level over 30%: blue LED ON / light level over 15%: blue LED flashing / light level under 15%: blue LED OFF

3) Check Ambient Light

Ambient light alarm is activated if external ambient light is detected or if emitter/receiver operation timing is affected. (Ambient light algorithm)



Easy Installation

The SFL/SFLA series features easy installation. Standard and adjustable brackets are available and can be installed on top, bottom, or middle of the units. The adjustable brackets can be adjusted by 15 degrees to right or left for easier installation.

One-Touch Bracket

The push-to-install one-touch method allows easier installation.

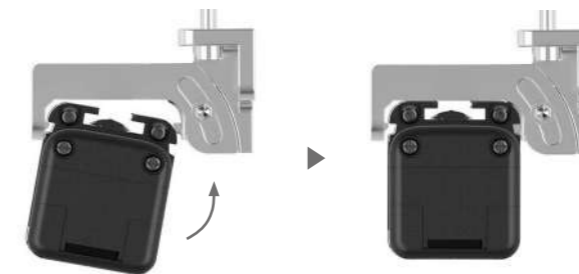

Adjustable Brackets

The adjustable brackets can be adjusted by 15 degrees to right or left after installation for easier setting.

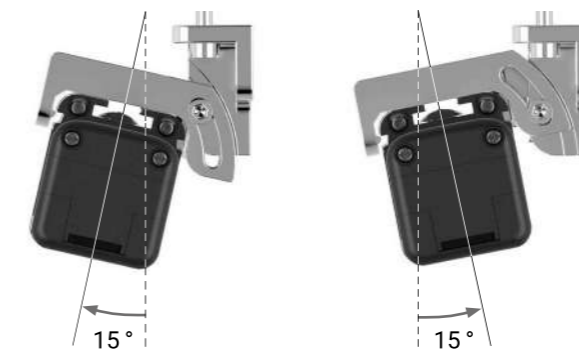

Brackets by Light Curtain Length

Brackets	Length	Max. 1 m	Min. 1 m
	Top/Bottom adjustable bracket		Requires 2 brackets
Top/Bottom bracket			
Side adjustable bracket		Requires 2 brackets	Requires 3 brackets
Side bracket			



Safety Light Curtain Software, atLightCurtain

atLightCurtain is a dedicated software for SFL/SFLA series safety light curtains to monitor operation status and set functions. Users can set various safety-related functions including muting, blanking from the parameter menu and monitor various operation status including light amount, connection, and errors.

* Detailed settings and features may not be available on standard type SFL series.



1. User-Oriented Graphic Interface

The atLightCurtain software screen features ribbon menus with status display, monitoring, and setting screens. The intuitive icons and user-oriented interface allows even novice users to easily operate the software. The setting and monitoring screens can be expanded to show diverse range of information.

- 1 **Ribbon menu** main software functions
- 2 **Status display screen** product information and operation status
- 3 **Monitoring and setting screen** product connection and monitoring information, safety functions
- 4 **Monitoring** light level by beam, connection, errors/alarms, etc.
- 5 **Safety-related functions** model settings, muting, blanking, and other settings

2. Various Safety-Related Functions

Industrial settings vary greatly by size and type, and potential dangers can occur from various environmental factors. Users can set muting, blanking, and other safety-related functions on the SFLA series with the atLightCurtain software.

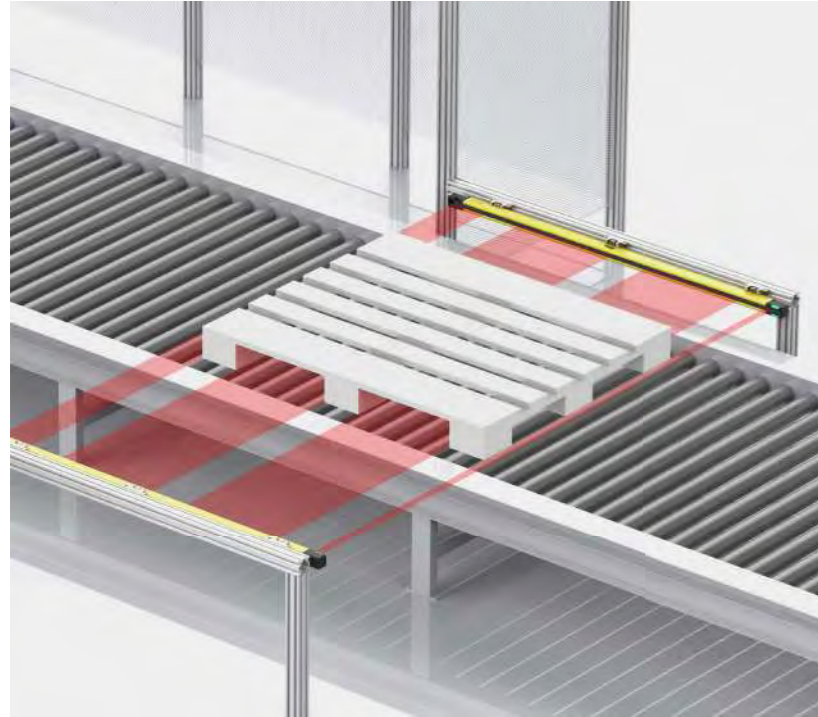

1) Reduced Resolution

Reduced resolution is a function for changing the detection capability of the light curtain. It prevents the control output from turning OFF when an object moving through the light curtain is smaller than the designated size. Reduced resolution can be set for all areas within the detection area, and up to 3 beams can be set to be ignored.

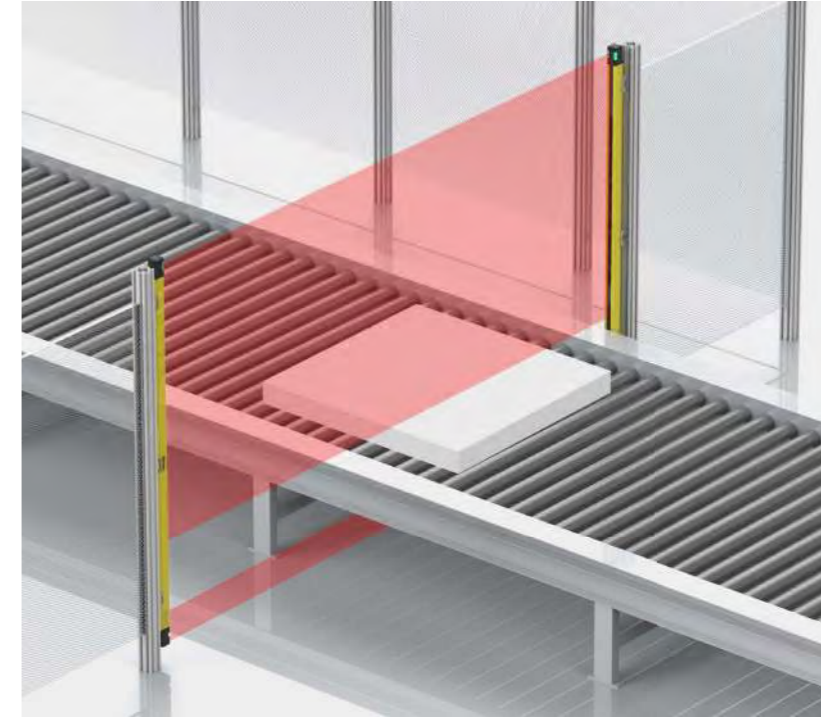

3) Blanking

Blanking function allows users to set selected beams blanking zones, preventing detection of objects in the blanking zone. This function can be used if an object or machine is located within the detection area, partially blocking some beams.

Blanking Function Types

Fixed Blanking	Used when an object or machine is continuously blocking certain beams.
Floating Blanking	Used when an fixed-sized object is moving. The blanking area changes with the moving object.

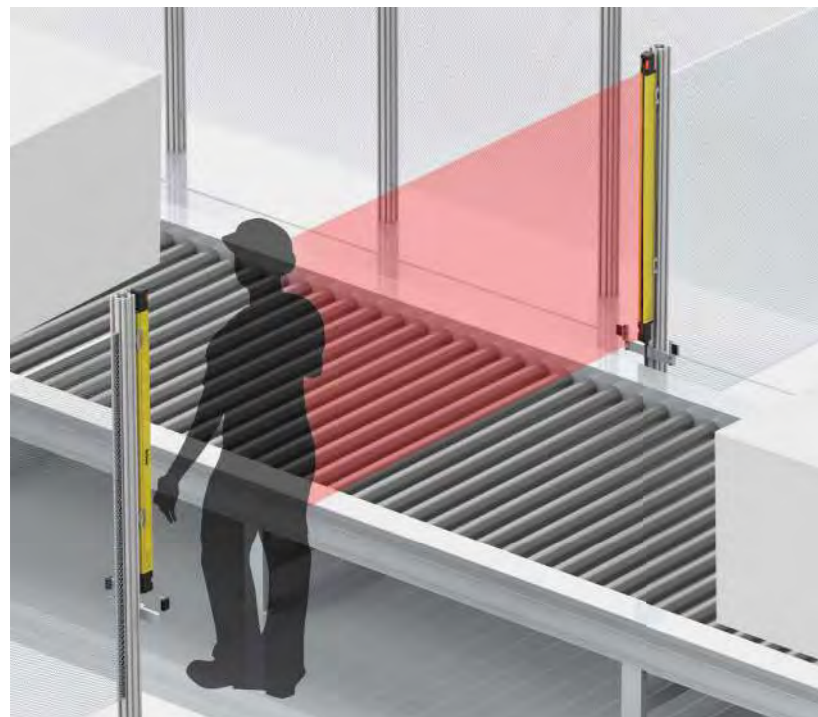

2) Muting

Muting function is a function to prevent the control output from turning OFF when an object is detected moving through the curtain. The light curtains can be set so that machines will stop operation only when a person is detected by muting the beams where objects may pass. The muting area can be set for the entire detection area or only for selected areas.

Muting Function Types

Standard Mode	Default muting function that starts and ends muting status by the set conditions.
Exit-Only Mode	Maintains muting status until object has completely cleared the area.



4) Override

Override function is used when the muting function ends and operation resumes, but the object is still within the detection area. The override function can be used to turn output ON to remove the object in the moving direction.

Light Curtain Selection Guide

Choose the correct light curtain model by following the directions below.

Step 1. Select model by purpose of use.



1 Select type

Select standard or high performance type depending on required needs.

Classification	Function	SFL Series (Standard type)	SFLA Series (High performance type)
General functions	Mode and status	○	○
	Self-test		
	RS485 communication (between emitter and receiver)		
	Monitor light incident level		
	OSSD output		
	Mutual interference prevention		
Safety-related functions	Interlock	○	●
	Lockout reset	○	○
	External device monitoring (EDM)	○	●
	Muting	○	●
	Override	○	●
	Blanking (Fixed blanking and floating blanking)	X	●
	Reduced resolution	X	●
Other functions	Series connection	○	○
	Select sensing distance		
	Select NPN or PNP		
	External test (light emission stops)		
	Auxiliary output (AUX)	○	●
	Lamp output (Lamp)	○	●
	PC connection	○	●
Type		No-mark	A

2 Select detection capability

Select the detection capability type. (finger, hand, body)

Detection type	Detection object size		Tag
Finger	ø14mm		□□□(□)14
Hand	ø20mm		□□□(□)20
Body	ø30mm		□□□(□)30

● : Supported (detailed settings available) / ○ : Supported (detailed settings unavailable) / X : Not supported

3 Select number of beams

Select the number of beams by detection capability.

Finger detection type			Hand detection type			Body detection type		
No. of beams	Protection height (mm)	Tag	No. of beams	Protection height (mm)	Tag	No. of beams	Protection height (mm)	Tag
15	144	□□□(□)14-15	12	183	□□□(□)20-12	9	218	□□□□30-9
23	216	□□□(□)14-23	16	243	□□□(□)20-16	12	293	□□□□30-12
31	288	□□□(□)14-31	20	303	□□□(□)20-20	15	368	□□□□30-15
39	360	□□□(□)14-39	24	363	□□□(□)20-24	18	443	□□□□30-18
47	432	□□□(□)14-47	28	423	□□□(□)20-28	21	518	□□□□30-21
55	504	□□□(□)14-55	32	483	□□□(□)20-32	24	593	□□□□30-24
63	576	□□□(□)14-63	36	543	□□□(□)20-36	27	668	□□□□30-27
71	648	□□□(□)14-71	40	603	□□□(□)20-40	30	743	□□□□30-30
79	720	□□□(□)14-79	44	663	□□□(□)20-44	33	818	□□□□30-33
87	792	□□□(□)14-87	48	723	□□□(□)20-48	36	893	□□□□30-36
95	864	□□□(□)14-95	52	783	□□□(□)20-52	39	968	□□□□30-39
103	936	□□□(□)14-103	56	843	□□□(□)20-56	42	1,043	□□□(□)30-42
111	1,008	□□□(□)14-111	60	903	□□□(□)20-60	45	1,118	□□□(□)30-45
119	1,080	□□□14-119	64	963	□□□(□)20-64	48	1,193	□□□(□)30-48
127	1,152	□□□14-127	68	1,023	□□□(□)20-68	51	1,268	□□□(□)30-51
135	1,224	□□□14-135	72	1,083	□□□□20-72	54	1,343	□□□(□)30-54
143	1,296	□□□14-143	76	1,143	□□□□20-76	57	1,418	□□□(□)30-57
151	1,368	□□□14-151	80	1,203	□□□□20-80	60	1,493	□□□(□)30-60
159	1,440	□□□14-159	84	1,263	□□□□20-84	63	1,568	□□□(□)30-63
167	1,512	□□□14-167	88	1,323	□□□□20-88	66	1,643	□□□(□)30-66
175	1,584	□□□14-175	92	1,383	□□□□20-92	69	1,718	□□□(□)30-69
183	1,656	□□□14-183	96	1,443	□□□□20-96	72	1,793	□□□(□)30-72
191	1,728	□□□14-191	100	1,503	□□□□20-100	75	1,868	□□□(□)30-75
199	1,800	□□□14-199	104	1,563	□□□□20-104			
			108	1,623	□□□□20-108			
			112	1,683	□□□□20-112			
			116	1,743	□□□□20-116			
			120	1,803	□□□□20-120			
			124	1,863	□□□□20-124			

Step 2. Select cables by condition.

Name	Shape	Model		Length (m)
		Emitter (black)	Receiver (black)	
Power I/O cables (connector type)		SFL-BCT	SFL-BCR	0.3
Power I/O cables (cable connector type)		SFL-C3T	SFL-C3R	3
		SFL-C7T	SFL-C7R	7
		SFL-C10T	SFL-C10R	10
		SFL-C15T	SFL-C15R	15
Connector cables (socket type)		CID8-3T	CID8-3R	3
		CID8-5T	CID8-5R	5
		CID8-7T	CID8-7R	7
		CID8-10T	CID8-10R	10
		C1D8-3T	C1D8-3R	3
Connector cables (socket-plug type)		C1D8-5T	C1D8-5R	5
		C1D8-7T	C1D8-7R	7
		C1D8-10T	C1D8-10R	10
		C1D8-15T	C1D8-15R	15
		C1D8-20T	C1D8-20R	20
		SFL-EC03T	SFL-EC03R	0.3
Serial expansion cables		SFL-EC3T	SFL-EC3R	3
		SFL-EC7T	SFL-EC7R	7
		SFL-EC10T	SFL-EC10R	10
		SFL-LC		3
Lamp output cables				
USB/Serial communication converters		SCM-US		1.5
Converter cables		EXT-SFL		0.3

Step 3. Select installation brackets.

Type	Top/bottom brackets	Mid-area brackets
Adjustable type	<p>Top/bottom adjustable brackets BK-SFL-TBA</p> 	<p>Mid-area adjustable brackets BK-SFL-SA</p> 
Standard type	<p>Top/bottom brackets BK-SFL-TBF</p> 	<p>Mid-area brackets BK-SFL-SF</p> 

Light Curtains

SFL/SFLA Series

Technical Overview

Dimensions

Unit: mm, For the detailed dimensions of the product, follow the Autonics web site. This dimension is based on the SFL(A) 14 model. The appearance varies depending on the detection capability.

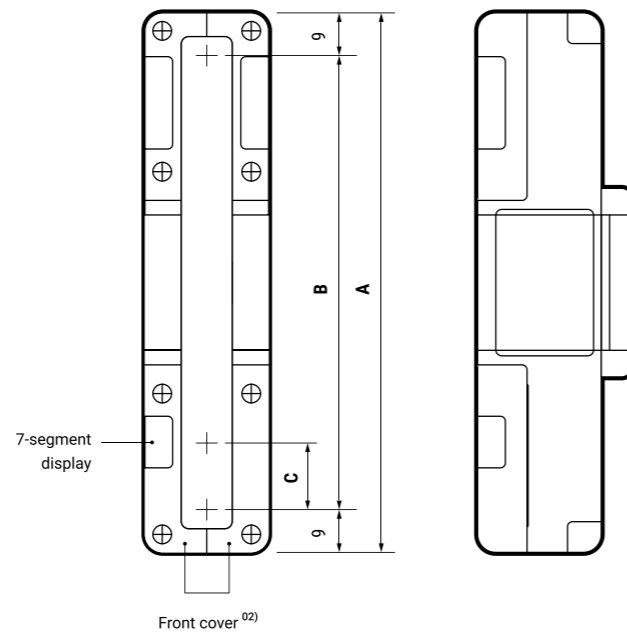
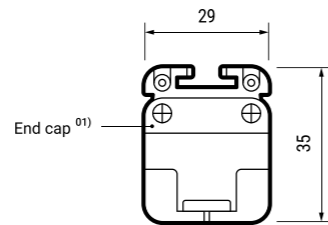

01) When removing the end cap, there is the lamp output terminal (top) or the power supply terminal (bottom).

02) When removing the front cover, there is the setting switch (on the emitter and the receiver) or the PC communication port (on the receiver).

Detection capability	Models	Number of beams	A (protective height)	B (sensing height)	C (optical axis pitch)
Ø 14 mm (finger)	Standard	15 to 111	144 to 1,008	126 to 990	9
	Advanced	15 to 199	144 to 1,800	126 to 1,782	
Ø 20 mm (hand)	Standard	12 to 68	183 to 1,023	165 to 1,005	15
	Advanced	12 to 124	183 to 1,863	165 to 1,845	
Ø 30 mm (hand-body)	Standard	42 to 75	1,043 to 1,868	1,025 to 1,850	25
	Advanced	9 to 75	218 to 1,868	200 to 1,850	

Ordering Information

This is only for reference. For selecting the specific model, follow the Autonics web site.

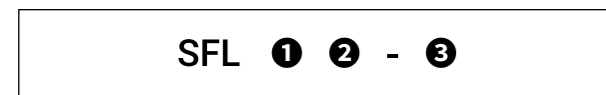

1 Type

No-mark: Standard type
A: High performance type

2 Detection capability

14: Ø 14 mm, finger
20: Ø 20 mm, hand
30: Ø 30 mm, hand-body

3 Number of optical axes

Number: Number of optical axes

Specifications

Type	Standard type		
Models	SFL14-□	SFL20-□	SFL30-□
Sensing type	Through-beam		
Light source	Infrared LED (855 nm)		
Effective aperture angle (EAA)	Within ± 2.5 ° when the sensing distance is greater than 3 m for both emitter and receiver.		
Sensing distance	Short - Long mode (setting switch)		
Short mode	0.2 to 5 m	0.2 to 8 m	0.2 to 8 m
Long mode	0.2 to 10 m	0.2 to 15 m	0.2 to 15 m
Detection capability	Ø 14 mm (finger)	Ø 20 mm (hand)	Ø 30 mm (hand-body)
Detection object	Opaque object		
Number of optical axes 01)	15 to 111	12 to 68	42 to 75
Protective height	144 to 1,008 mm	183 to 1,023 mm	1,043 to 1,868 mm
Optical axis pitch	9 mm	15 mm	25 mm
Series connection	Max. 3 SET (≤ 300 optical axes)		

Type	Advanced type		
Models	SFLA14-□	SFLA20-□	SFLA30-□
Sensing type	Through-beam		
Light source	Infrared LED (855 nm)		
Effective aperture angle (EAA)	Within ± 2.5 ° when the sensing distance is greater than 3 m for both emitter and receiver.		
Sensing distance	Short - Long mode (setting switch or atLightCurtain)		
Short mode	0.2 to 5 m	0.2 to 8 m	0.2 to 8 m
Long mode	0.2 to 10 m	0.2 to 15 m	0.2 to 15 m
Detection capability	Ø 14 mm (finger)	Ø 20 mm (hand)	Ø 30 mm (hand-body)
Detection object	Opaque object		
Number of optical axes 01)	15 to 199	12 to 124	9 to 75
Protective height	144 to 1,800 mm	183 to 1,863 mm	218 to 1,868 mm
Optical axis pitch	9 mm	15 mm	25 mm
Series connection	Max. 4 SET (≤ 400 optical axes)		

01) It may differ depending on the models. For more information, see the 'SFL/SFLA User Manual'.

Power supply	24 VDC±± 20 % (Ripple P-P: ≤ 10 %)
Current consumption 01)	Emitter: ≤ 106 mA, receiver: ≤ 181 mA
Response time 01)	T _{OFF} (ON → OFF): ≤ 32.3 ms, T _{ON} (OFF → ON): ≤ 76.6 ms
Safety related output :OSSD output	NPN or PNP open collector Load voltage 02): ON - 24 VDC± (except for the residual voltage), OFF - 0 VDC±, Load current 03): ≤ 300 mA, Residual voltage 04): ≤ 2 VDC± (except for voltage drop due to wiring), Load capability: ≤ 2.2 µF, Leakage current: ≤ 2.0 mA, Wire resistance of load: ≤ 2.7 Ω
Auxiliary output (AUX 1/2) 05)	NPN or PNP open collector Load voltage: ≤ 24 VDC±, Load current: ≤ 100 mA, Residual voltage: ≤ 2 VDC± (except for voltage drop due to wiring)
Lamp output (LAMP 1/2) 05)	NPN or PNP open collector Load voltage: ≤ 24 VDC±, Load current: ≤ 300 mA, Residual voltage: ≤ 2 VDC± (except for voltage drop due to wiring), Incandescent lamp: 24 VDC± / 3 to 7 W, LED lamp: Load current ≤ 10 to 300 mA (VF: ≤ 1.5 VDC±)
External input	Reset input, mute 1/2 input, EDM, external test When setting NPN output ON: 0 - 3 VDC±, OFF: 9 - 24 VDC± or open, short-circuit current: ≤ 3 mA When setting PNP output ON: 9 - 24 VDC±, OFF: 0 - 3 VDC± or open, short-circuit current: ≤ 3 mA
Protection circuit	Reverse power polarity, reverse output polarity, output short-circuit over-current protection
Safety-related functions	Interlock (reset hold), external device monitoring (EDM), muting/override, Blanking (fixed blanking, floating blanking), reduced resolution
General functions	Self-test, alarm for reduction of incident light level, mutual interference prevention
Others functions	Change of sensing distance, switching to NPN or PNP, external test (light emission stops), auxiliary output (AUX 1, 2), lamp output (LAMP1, 2)
Synchronization type	Timing method by RS485 synchronous line
Insulation resistance	≥ 20MΩ (at 500 VDC± megger)
Noise immunity	± 240 VDC± the square wave noise (pulse width: 1µs) by the noise simulation
Dielectric strength	1,000 VAC~ 50/60 Hz for 1 minute
Vibration	0.7 mm double amplitude at frequency of 10 to 55Hz (for 1 min), 20 sweeps in each X, Y, Z direction
Shock	100 m/s ² (≈ 10 G), pulse width 16 ms in each X, Y, Z direction for 1,000 times
Ambient illumination (receiver)	Incandescent lamp: ≤ 3,000 lx, sunlight: ≤ 10,000 lx
Ambient temperature	-10 to 55 °C, storage: -20 to 70 °C (no freezing or condensation)
Ambient humidity	35 to 85 %RH, storage: 35 to 95 %RH (no freezing or condensation)
Protection rating 06)	IP65, IP67 (IEC standard), IP67G (JEM Standard), IP69K (DIN standard)
Material	Case: Aluminum, Front cover and sensing part: Polymethyl methacrylate, End cap: polycarbonate, Power I/O cable and connector cable: polyurethane (PUR) or polyvinyl chloride (PVC), Y type connector cable: polyvinyl chloride (PVC), lamp output cable and series connector cable: polyurethane (PUR)
Approval	CE, S, (industrial robot protection device) 07)
International standards	UL 508, CSA C22.2 No. 14, ISO 13849-1 (PL e, Cat. 4), ISO 13849-2 (PL e, Cat. 4), UL 61496-1 (Type 4, ESPE), UL 61496-2 (Type 4, AOPDs), IEC/EN 61496-1 (Type 4, ESPE), IEC/EN 61496-2 (Type 4, AOPDs), IEC/EN 61508-1~7 (SIL 3), IEC/EN 62061 (SIL CL 3)

01) It may differ depending on the models. For more information, refer to the 'SFL/SFLA User Manual'.

02) The values of load voltage were drawn with PNP output, and in case of NPN output, apply these in reverse.

03) Be sure that the load current should be greater than 5 mA.

04) The residual voltage was drawn with 300 mA of load current.

05) It is the non-safety output. Do not use it for safety purposes.

06) Approved certification protection ratings are IP65 and IP67.

07) Refer to the 'SFL/SFLA User Manual' for certified by model. The certified models for S-mark and KCs (industrial robot protection device) have the same functional basis.

Opening a New Era of Safety

Safety Door Switches

SFD Series

The SFD series safety door switches can detect opening and closing of doors in machines. The head can be rotated to change the insert direction of the operation key from 5 directions, with 6 available operation key types. Also, the door switches are available in terminal type and connector type models, making it easier for installation in diverse application settings.

Safety Standards

IEC/EN 60947-5-1
EN ISO 14119
GB/T 14048.5

Certifications



Various Models Available for Flexible Installation

The SFD series door switches are available in terminal type and connector types for easy application and installation in diverse environments.

1. Head Rotation & 6 Operation Key Types

The SFD series offers diverse installation methods for flexible installation. The head can be rotated to change the insert direction of operation keys.

6 Operation Key Types

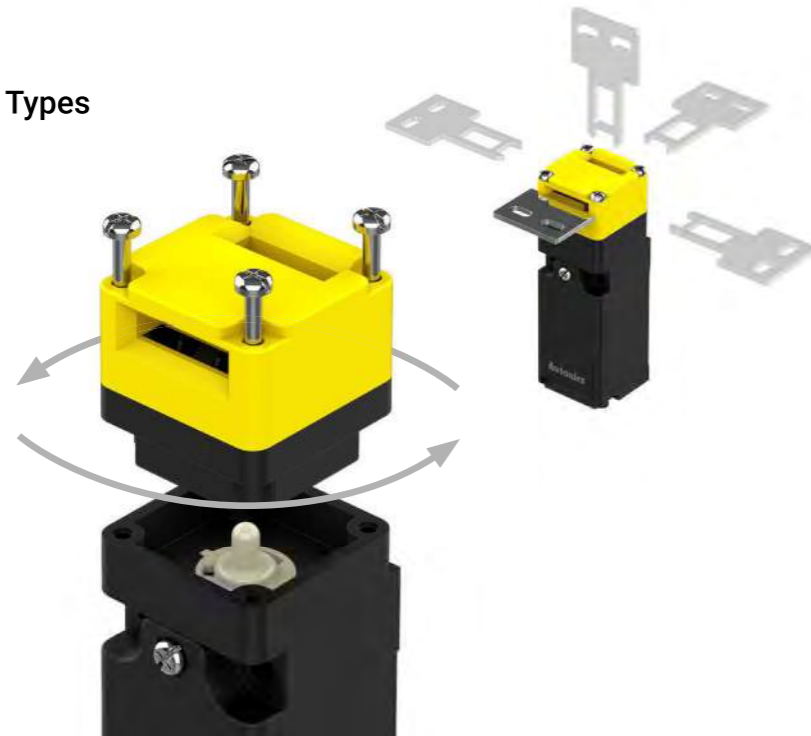

2. Two Model Types

Connector type and terminal type models are available for application in various environments. Both types can be detached easily from the body, for easier installation and maintenance.



Connector Type



Terminal Type

Slim and Compact Size

The door switches are slim and compact in size (H 92 x D 30 mm), allowing installation in tight or limited spaces.



Switches with up to 3 Contacts

2-contact or 3-contact switches are built in, with 4 types of contact configurations for easier application in any environment.

Model	Contact	Contact composition	Contact operation
SFD-□AB-□□	1 N.C., 1 N.O.		<div style="display: flex; justify-content: space-around;"> <div style="text-align: center;"> <p>Operation key complete insertion</p> </div> <div style="text-align: center;"> <p>Operation key extraction</p> </div> </div> <div style="display: flex; justify-content: space-around;"> <div style="text-align: center;"> <p>11-12</p> </div> <div style="text-align: center;"> <p>33-34</p> </div> </div>
SFD-□2B-□□	2 N.C.		<div style="display: flex; justify-content: space-around;"> <div style="text-align: center;"> <p>11-12</p> </div> <div style="text-align: center;"> <p>31-32</p> </div> </div>
SFD-□A2B-□□	2 N.C., 1 N.O.		<div style="display: flex; justify-content: space-around;"> <div style="text-align: center;"> <p>11-12</p> </div> <div style="text-align: center;"> <p>21-22</p> </div> <div style="text-align: center;"> <p>33-34</p> </div> </div>
SFD-□3B-□□	N.C. 3		<div style="display: flex; justify-content: space-around;"> <div style="text-align: center;"> <p>11-12</p> </div> <div style="text-align: center;"> <p>21-22</p> </div> <div style="text-align: center;"> <p>31-32</p> </div> </div>

Contact composition represents the locked status with the operation key inserted. (■ ON, □ OFF)

Door Switches

SFD Series

Technical Overview

Ordering Information

This is only for reference. For selecting the specific model, follow the Autonics web site.



1 Head materials

No mark: Plastic
M: Metallic

2 Contact composition

AB: 1 N.O., 1 N.C.
2B: 2 N.C.
A2B: 1 N.O., 2 N.C.
3B: 3 N.C.

3 Connection outlet

No mark: 1
2: 2

4 Connection outlet specification

M20: M20 thread
G1/2: G1/2 thread
C: M12 connector

Dimensions

Unit: mm, For the detailed dimensions of the product, follow the Autonics web site.

Connector type

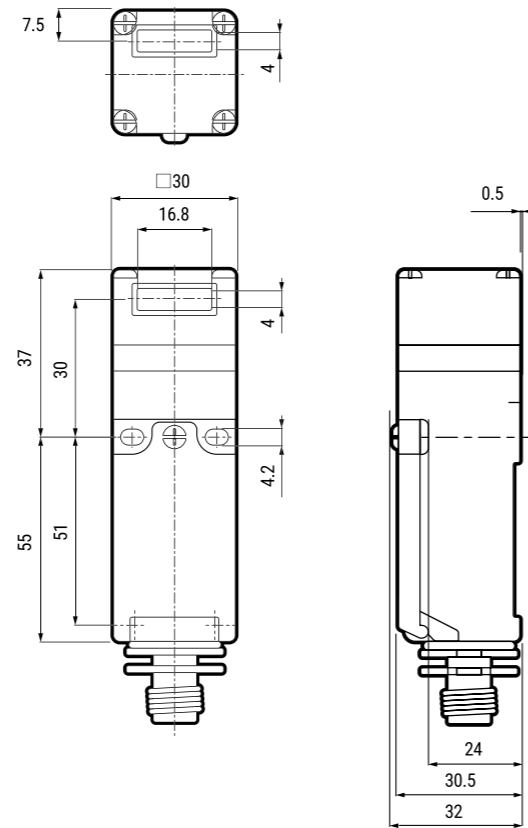

1 connection outlet terminal type

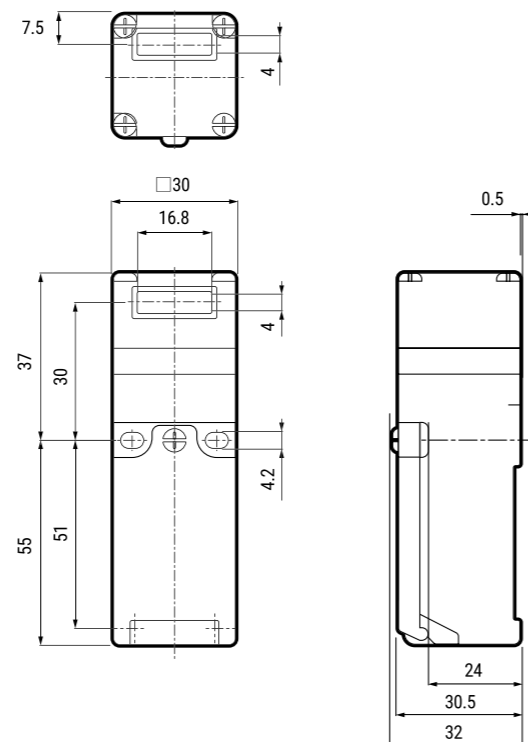

2 connection outlet terminal type

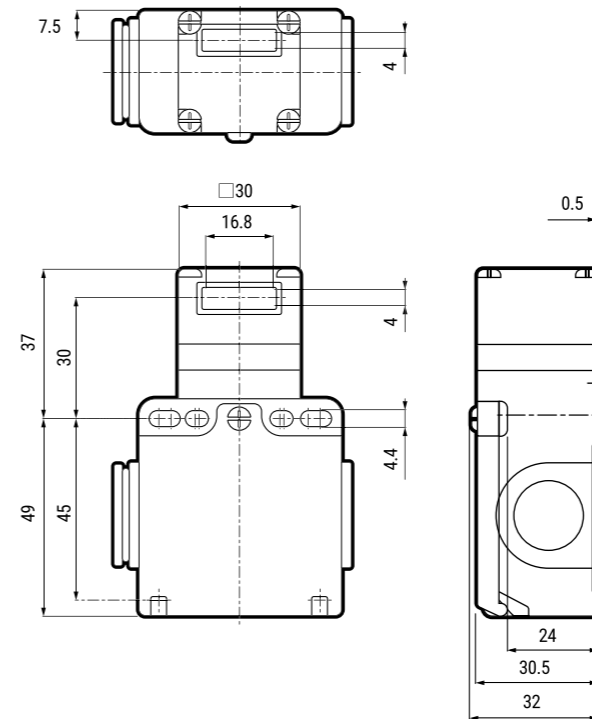

Mounting hole cut-out

• 1 connection outlet

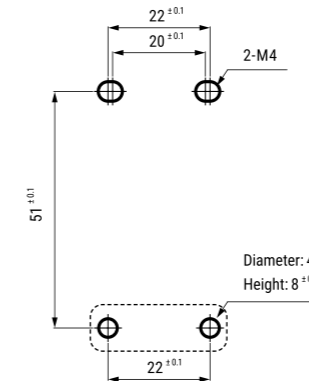

• 2 connection outlet

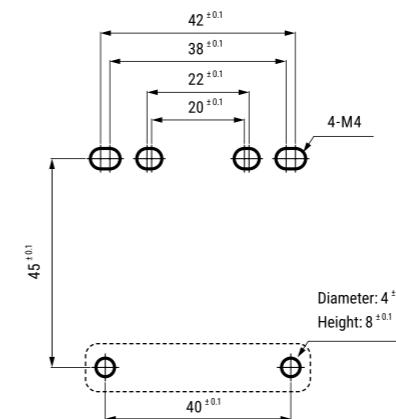

is installing spot of protrusion for fixing the switch firmly.

Specifications

Model	SFD-□□-□M20	SFD-□□-□G1/2	SFD-□□-□C
Rated voltage/current for load	Resistive load: 6 A/250 VAC, 0.6 A/250 VDC Inductive load (IEC): AC-15 3 A/240 VAC, DC-13 0.27 A/250 VDC Inductive load (UL): A300, Q300		
Directing opening force	≥ 80 N		
Directing opening distance	≥ 10 mm		
Operating speed	0.05 ~ 1 m/s		
Operating frequency	≤ 20/min		
Insulation resistance	≥ 100 MΩ (500 VDC= megger)		
Contact resistance	≤ 50 mΩ (initial value)		
Impulse dielectric strength	Between the terminals: 2 kV (IEC 60947-5-1) Between each terminal and non-live part: 5 kV (IEC 60947-5-1)		
Conditional short circuit current	100 A		
Life cycle	Electrical: ≥ 100,000 operations (240 VAC~ 6 A) Mechanical: ≥ 1,000,000 operations		
Vibration (malfunction)	0.75 mm amplitude at frequency of 10 to 55 Hz (for 1 min) in each X, Y, Z direction for 10 min		
Shock	1,000 m/s ² (≈ 100 G) in each X, Y, Z direction for 3 times		
Shock (malfunction)	300 m/s ² (≈ 30 G) in each X, Y, Z direction for 3 times		
Ambient temperature	-30 to 70°C, storage: -40 to 70°C ⁰¹⁾ (no freezing or condensation)		
Ambient humidity	35 to 90 %RH, storage: 35 to 90 %RH (no freezing or condensation)		
Protection structure	IP67 ⁰²⁾ (IEC standard, except for head)		
Material	Plastic head - polyamide 6, metallic head - zinc case: polyamide 6, operation key: stainless steel 304		
Approval	CE, UL, VDE, TÜV, ENEC, ETL, ENEC		
Connection type	M20 connector cable	G1/2 connector cable	M12 plug connector
Unit weight (packaged)	• 1 connection outlet plastic: ≈ 80 g (≈ 120 g) metallic: ≈ 110 g (≈ 150 g)		plastic: ≈ 85 g (≈ 130 g) metallic: ≈ 115 g (≈ 160 g)

01) UL approved ambient temperature: 65°C

02) Rated protection structure is for the switch body. Be cautious about preventing the head part from entering the foreign materials such as dust and water.



The Key to Your Safety

Safety Door Lock Switches

SFDL Series

The SFDL series safety door lock switches can detect opening and closing of doors in machines, and also keep the door locked during potentially dangerous operation. The head can be rotated to change the insert direction of the operation key from 5 directions, with 6 available operation key types. Various types of connection and release keys are also available, making it easier for installation in diverse application settings.

Safety Standards

IEC/EN 60947-5-1
EN ISO 14119
GB/T 14048.5

Certifications



Various Models Available for Flexible Installation

The SFDL series door lock switches are available in terminal type and connector types for easy application and installation in diverse environments.

1. Head Rotation & 6 Operation Key Types

The SFDL series offers diverse installation methods for flexible installation. The head can be rotated to change the insert direction of operation keys.

6 Operation Key Types

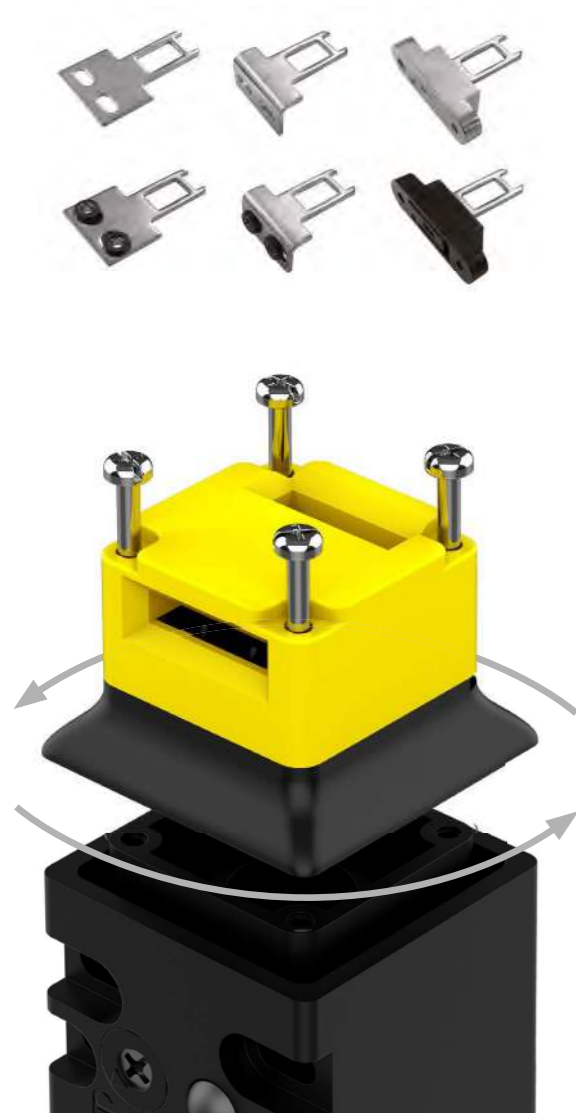

2. Two Model Types

Terminal type and connector type models are available for application in various environments. Both types can be detached easily from the body, for easier installation and maintenance.

Terminal Type



Connector Type



Connector cable (sold separately)

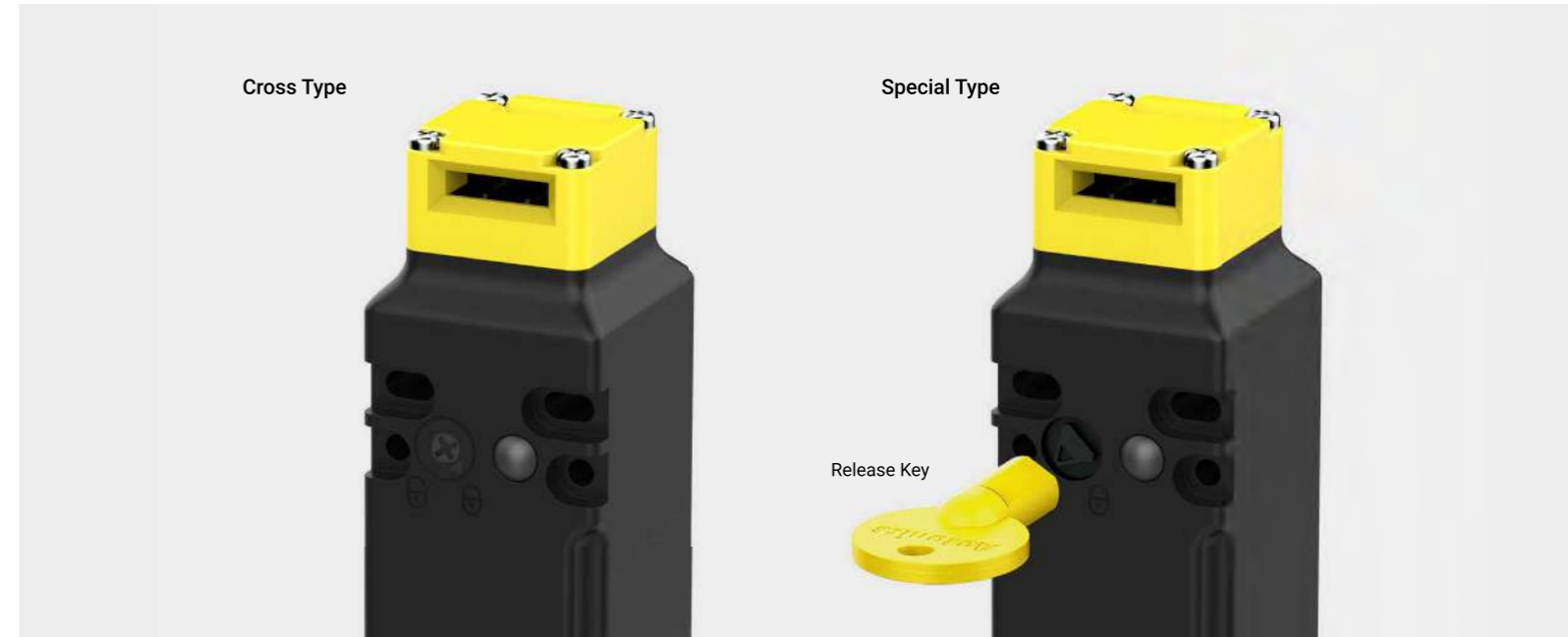

3. Release Keys Available

Cross type and special type release keys are available for wider options. Release keys can be used to manually unlock the units during emergency or product malfunction. The metallic release levers offer high durability.

4. Two Types of Lock/Release Methods

Two types of lock/release methods are available (Mechanical lock & solenoid release / solenoid lock & mechanical release). The mechanical lock remains locked when the operation key is inserted and unlocks with solenoid power. The solenoid lock remains locked with solenoid power and unlocks when solenoid power is cut off.

Release Key

Release key type	Normal position	Manual unlock position
Cross type		
Special type		

Lock/Release Method

	Mechanical Lock	Solenoid Lock
Power ON	UNLOCK	LOCK
Power OFF	LOCK	UNLOCK



5. Powerful Lock Strength

Powerful lock strength of 1,300 N ensures that the unit will remain locked under most conditions.



6. Slim and Compact Size

The door lock switches are slim and compact in size (H 155 x D 40 mm), allowing installation in tight or limited spaces.

* Connector type (H 155 x D40 mm), terminal type (H 180 x D 40mm)

Switches with up to 6 Contacts

4-contact, 5-contact, or 6-contact switches are built in, with 16 types of contact configurations for easier application in any environment.

Model	Contact (lock monitor+ door monitor)	Connection diagram		Contact operation
		Lock monitor	Door monitor	
				Operation key complete insertion: Operation key extraction:
SFDL-□A-□□□	1NC./1NO.+1NC./1NO.			Lock position: 42-11 34-33 64-63
SFDL-□B-□□□	2NC.+1NC./1NO.			Lock position: 42-11 34-33 62-61
SFDL-□C-□□□	1NC./1NO.+2NC.			Lock position: 42-11 32-31 64-63
SFDL-□D-□□□	2NC.+2NC.			Lock position: 42-11 32-31 62-61
SFDL-□CA-□□□	1NC./1NO.+1NC./1NO.			Lock position: 42-41 22-21 34-33 64-63
SFDL-□CB-□□□	2NC.+1NC./1NO.			Lock position: 42-41 22-21 34-33 62-61
SFDL-□CC-□□□	1NC./1NO.+2NC.			Lock position: 42-41 22-21 32-31 64-63
SFDL-□CD-□□□	2NC.+2NC.			Lock position: 42-41 22-21 32-31 62-61
SFDL-□5A-□□□	1NC./1NO.+2NC./1NO.			Lock position: 42-11 22-21 34-33 64-63
SFDL-□5B-□□□	2NC.+2NC./1NO.			Lock position: 42-11 22-21 34-33 62-61
SFDL-□5C-□□□	1NC./1NO.+3NC.			Lock position: 42-11 22-21 32-31 64-63
SFDL-□5D-□□□	2NC.+3NC.			Lock position: 42-11 22-21 32-31 62-61
SFDL-□6A-□□□	2NC./1NO.+2NC./1NO.			Lock position: 42-11 52-21 34-33 64-63
SFDL-□6B-□□□	3NC.+2NC./1NO.			Lock position: 42-11 52-21 34-33 62-61
SFDL-□6C-□□□	2NC./1NO.+3NC.			Lock position: 42-11 52-21 32-31 64-63
SFDL-□6D-□□□	3NC.+3NC.			Lock position: 42-11 52-21 32-31 62-61

Connection diagram represents the locked status with the operation key inserted. (■ ON, □ OFF)

Door Lock Switches

SFDL Series

Technical Overview

Ordering Information

This is only for reference. For selecting the specific model, follow the Autonics web site.

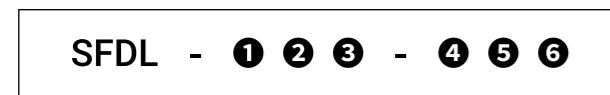

① Lock/Release method

M: Mechanical Lock/Solenoid Release
S: Solenoid Lock/Mechanical Release

② Contact

No-mark: 4-contact (connected)
C: 4-contact (not connected)
5: 5-contact
6: 6-contact

③ Contact composition

	4-contact	5-contact	6-contact
A	Lock 1 N.C. / 1 N.O. + Door 1 N.C. / 1 N.O.	Lock 1 N.C. / 1 N.O. + Door N.C. 2 / N.O. 1	Lock 2 N.C. / 1 N.O. + Door 2 N.C. / 1 N.O.
B	Lock N.C. 2 + Door N.C. 1 / N.O. 1	Lock N.C. 2 + Door N.C. 2 / N.O. 1	Lock N.C. 3 + Door N.C. 2 / N.O. 1
C	Lock N.C. 1 / N.O. 1 + Door N.C. 2	Lock N.C. 1 / N.O. 1 + Door N.C. 3	Lock N.C. 2 / N.O. 1 + Door N.C. 3
D	Lock N.C. 2 + Door N.C. 2	Lock N.C. 2 + Door N.C. 3	Lock N.C. 3 + Door N.C. 3

④ Connection type

No-mark: Terminal type
C: Connector type

⑤ Connection outlet specification

M20: M20 thread
G1/2: G1/2 thread

⑥ Release key type

No-mark: Cross type
K: Special type

Dimensions

Unit: mm, For the detailed dimensions of the product, follow the Autonics web site.

Terminal type

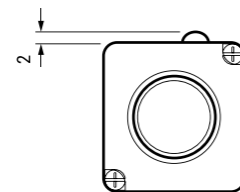
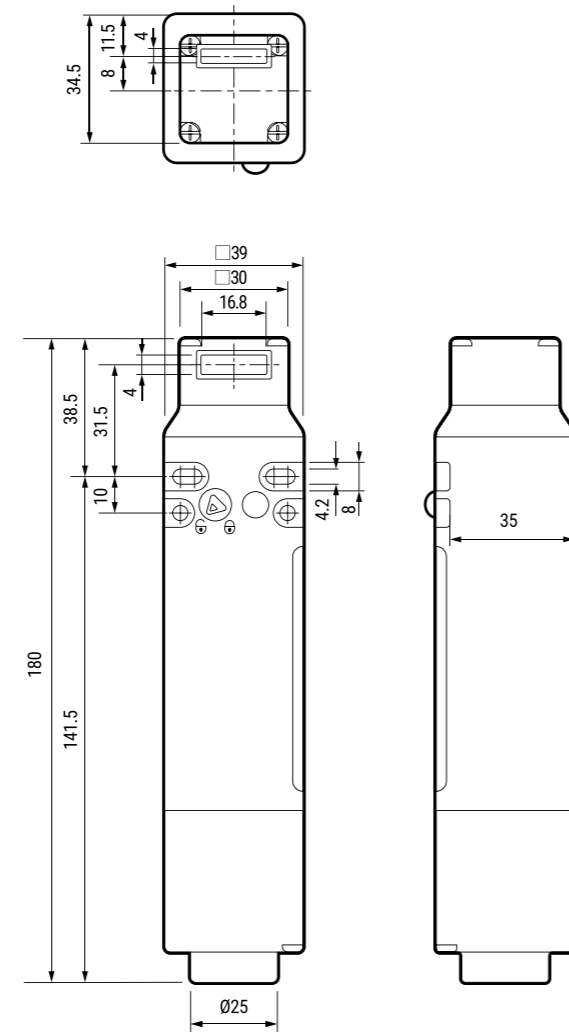

Connector type

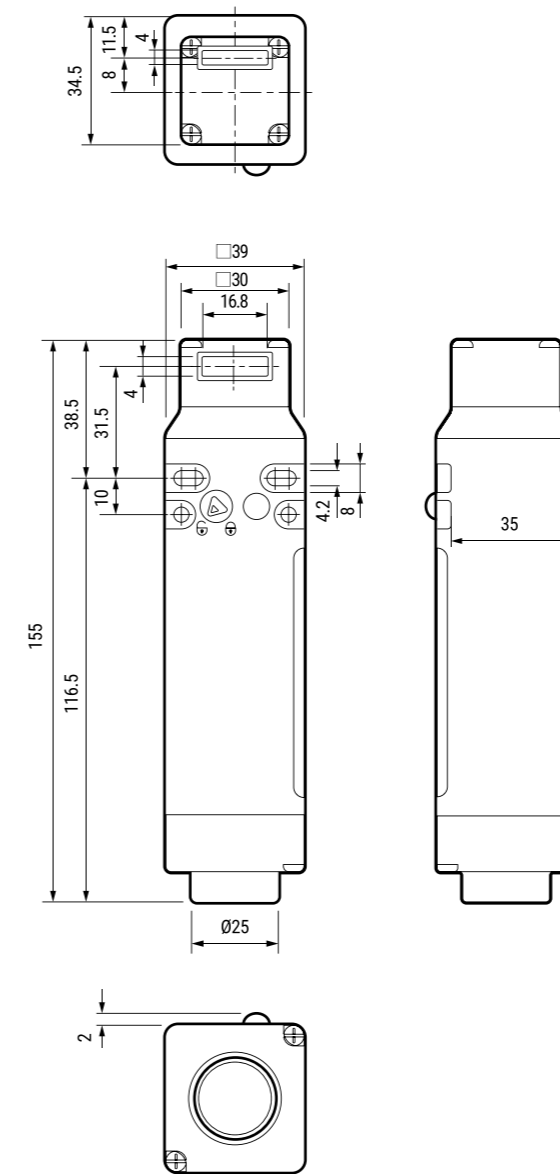

Panel cut out

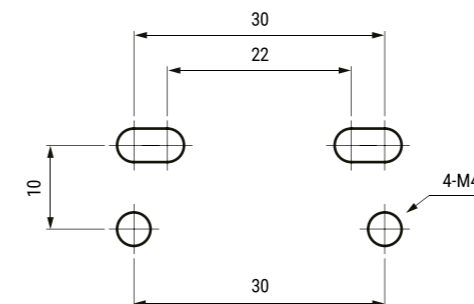

Specifications

Model	SFDL-□□□-□□	SFDL-□□□-C□□
Directing opening force	≥ 80 N	
Directing opening distance	≥ 10 mm	
Locking pullout strength	≥ 1,300 N	
Operating speed	0.05 to 1 m/s	
Operating frequency	≤ 20/min	
Mechanical life cycle	≥ 1,000,000 operations (20/min)	
Vibration (malfunction)	0.35 mm amplitude at frequency of 10 to 55 Hz (for 1 min) in each X, Y, Z direction for 10 min	
Shock	1,000 m/s ² (≈ 100 G) in each X, Y, Z direction for 3 times	
Shock (malfunction)	80 m/s ² (≈ 8 G) in each X, Y, Z direction for 3 times	
Ambient temperature	-10 to 55°C ⁰¹⁾ , storage: -25 to 65 °C (a non freezing or condensation environment)	
Ambient humidity	35 to 85 %RH, storage: 35 to 85 %RH (a non freezing or condensation environment)	
Protection structure	IP67 ⁰²⁾ (IEC standard, except for head)	
Material	Head: zinc, case: polyamide 66, operation key: stainless steel 304	
Approval	CE (TUV NORD) - ENEC - ETL - EAC	
Accessory	SFDL-□□□-□□K (Special type release key) : rotating key	
Applicable cable	AWG22	-
Connection type	Terminal type	Connector type
Unit weight (packaged)	≈ 375 g (≈ 440 g)	≈ 325 g (≈ 395 g)

01) UL approved ambient temperature: 50°C
02) Rated protection structure is for the switch body. Be cautious about preventing the head part from entering the foreign materials such as dust and water.

Contact block	
Rated voltage/ current for load	Resistive load: 1 A/120 VAC~, 0.22 A/125 VDC= Inductive load (IEC): AC-15 1 A/120 VAC~, DC-13 0.22 A/125 VDC= Inductive load (UL): C150, R150
Impulse dielectric strength	Between the terminals of same polarity: 1.5 kV Between the terminals of different polarity: 1.5 kV Between each terminal and non-live part: 2.5kV
Insulation resistance	≥ 100 MΩ (500 VDC= megger)
Contact resistance	≤ 200 mΩ
Electrical life cycle	≥ 100,000 operations (125 VAC~/1 A)
Conditional short-circuit current	100 A
Solenoid	
Rated voltage	24 VDC=, class 2
Current consumption	Supplying power: 0.26A Normal: max. 0.2A (approx. 3 seconds after supplying power)
Insulation class	Class E

SFD-KLF, SFD-KLF2

Model	Material
SFD-KLF	Operation key: stainless steel 304, base: polyamide
SFD-KLF2	Operation key: stainless steel 304, base: zinc

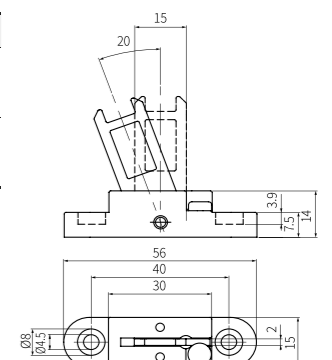

The Key to Your Safety

Flat Type Door Lock Switches

SFDL2 Series

The SFDL2 series safety flat type door lock switches can detect opening and closing of doors in machines, and also keep the door locked during potentially dangerous operation. The door lock switches feature slim size and front/rear installation for flexible installation in diverse application settings. The switches are also available in release button models for additional safety.

Safety Standards

IEC/EN 60947-5-1
EN ISO 14119
GB/T 14048.5

Certifications



Various Models Available for Flexible Installation

The SFDL2 series flat type door lock switches are available in various models and operation key types for flexible installation.

1. Head Rotation & 6 Operation Key Types

The SFDL2 series offers diverse installation methods for flexible installation with 6 operation key types. The head can be rotated to change the insert direction of operation keys.

6 Operation Key Types

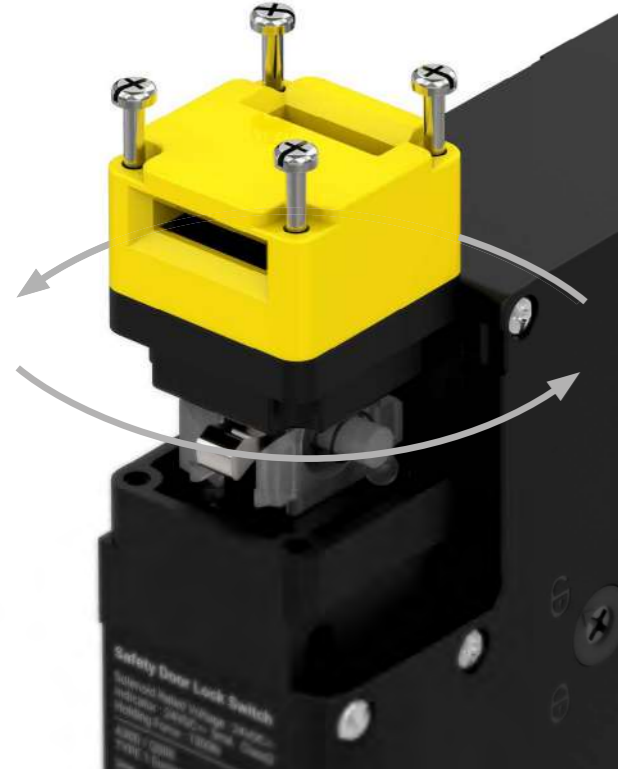

2. Front / Rear Installation Types Available

The switches are available in front / rear installation models depending installation requirements. Release button models are also available, allowing operators to unlock the unit manually while inside the operating area.



Front Installation



Rear Installation

Release Key



Standard Type (Cross)



Special Release Key Type

Rear Release Button



Front Installation Type

3. Release Keys Available

Release keys can be used to unlock the device during power outages or emergency. Standard cross type and special type release keys are available.

* This function can not be used to stop machine operation.

Release key

Release key	Normal	Manual unlock
Cross type		
Special type		

4. Two Types of Lock/Release Methods

Two types of lock/release methods are available (Mechanical lock & solenoid release / solenoid lock & mechanical release). The mechanical lock remains locked when the operation key is inserted and unlocks with solenoid power. The solenoid lock remains locked with solenoid power and unlocks when solenoid power is cut off.

Lock/ Release Method

	Mechanical Lock	Solenoid Lock
Power ON	UNLOCK	LOCK
Power OFF	LOCK	UNLOCK



5. Powerful Lock Strength

Powerful lock strength of 1,300 N ensures that the unit will remain locked under most conditions.



6. Slim and Compact Size

The door lock switches are slim and compact in size (W90 X H105 X D30 mm), allowing installation in tight or limited spaces.

* Rear Installation

Switches with up to 6 Contacts

6-contact switches are built-in, with 4 types of contact configurations for easier application in any environment.

Model	Contact (lock monitor+ door monitor)	Connection diagram		Contact operation
		Door monitor	Lock monitor	
				Operation key complete insertion
SFDL2-□□6A-□□□□□	2NC./1NO. + 2NC./1NO.			Lock position
SFDL2-□□6B-□□□□□	3NC. + 2NC./1NO.			Lock position
SFDL2-□□6C-□□□□□	2NC./1NO. + 3NC.			Lock position
SFDL2-□□6D-□□□□□	3NC. + 3NC.			Lock position

Connection diagram represents the locked status with the operation key inserted. (■ ON, □ OFF)

Flat Type Door Lock Switches SFDL2 Series

Technical Overview

Ordering Information

This is only for reference. For selecting the specific model, follow the Autonics web site.

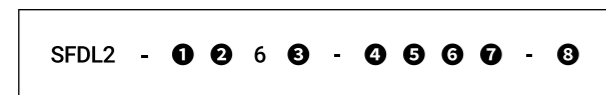

1 Head material

No mark: Metallic
P: Plastic

2 Lock/Release method

M: Mechanical Lock/Solenoid Release
S: Solenoid Lock/Mechanical Release

3 Contact composition

A: Lock 2 N.C./1 N.O. + Door 2 N.C./1 N.O.
B: Lock 3 N.C. + Door 2 N.C./1 N.O.
C: Lock 2 N.C./1 N.O. + Door 3 N.C.
D: Lock 3 N.C. + Door 3 N.C.

4 Installation direction

No-mark: Front installation
B: Rear installation

5 Connection outlet specification

M20: M20 thread
G1/2: G1/2 thread

6 Release key type

No-mark: Cross type
K: Special type

7 Rear release button

No-mark: None
B: Exist

8 Release key position

No-mark: Front
T: Bottom

Dimensions

Unit: mm, For the detailed dimensions of the product, follow the Autonics web site.

Front installation

The parts marked with a dotted line are dimensions applicable only to the rear release button existing type.

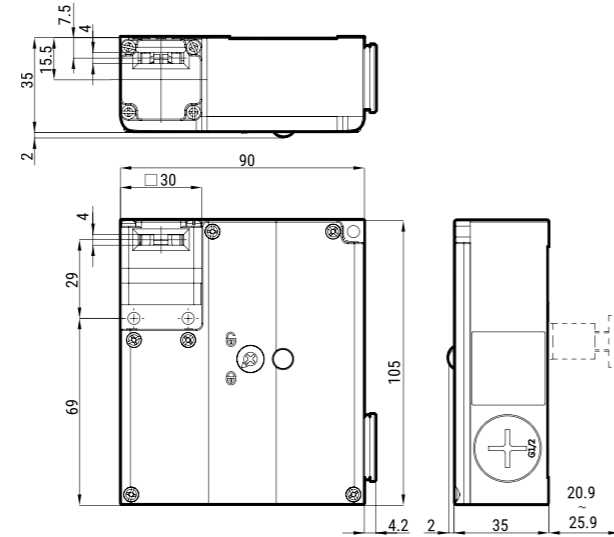

Rear installation

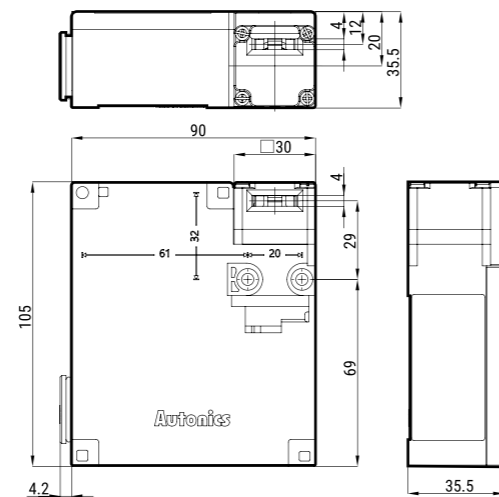

Panel cut-out

• Front installation

• Rear installation

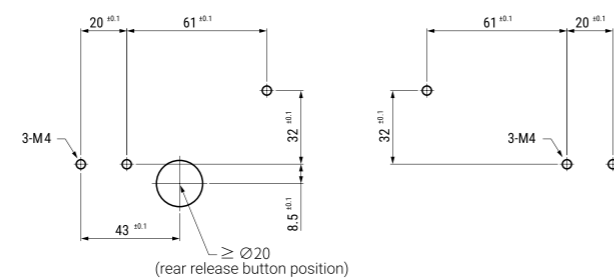

Specifications

Model	SFDL2-□□□□□□ -□□ SFDL2-□□□□□□K-□□	SFDL2-□□□□□□ B-□□ SFDL2-□□□□□□KB-□□
Directing opening force	≥ 80 N	
Directing opening distance	≥ 10 mm	
Locking pullout strength	≥ 1,300 N	
Operating speed	0.05 to 1 m/s	
Operating frequency	≤ 20/min	
Mechanical life cycle	≥ 1,000,000 operations (20/min)	
Indicator	Solenoid status or contact status (orange, depending on connection)	-
Vibration (malfunction)	0.35mm amplitude at frequency of 10 to 55 Hz (for 1 min) in each X, Y, Z direction for 10 min	
Shock	1,000 m/s ² (= 100 G) in each X, Y, Z direction for 3 times	
Shock (malfunction)	80 m/s ² (= 8 G) in each X, Y, Z direction for 3 times	
Ambient temperature	-10 to 55°C, storage: -25 to 65 °C (a non freezing or condensation environment)	
Ambient humidity	35 to 85 %RH, storage: 35 to 85 %RH (a non freezing or condensation environment)	
Protection structure	IP67 ⁽¹⁾ (IEC standard, except for head)	
Material	Head: zinc or PA, case: PA	
Approval	CE (TUV NORD) iEC (UL) S	
Accessory	SFDL2-□□□□□□K/KB-□□ (Special type release key); rotating key	
Unit weight (packaged)	Normal type: ≈ 400 g (= 490 g), rear release button type: ≈ 395 g (= 485 g)	

(1) Rated protection structure is for the switch body. Be cautious about preventing the head part from entering the foreign materials such as dust and water.

Contact block	
Rated voltage/current for load	Resistive load: 6 A/250 VAC~, 0.6 A/250 VDC= Inductive load (IEC): AC-15 3 A/240 VAC~, DC-13 0.27 A/250 VDC= Inductive load (UL): A300, Q300
Impulse dielectric strength	Between the terminals of same polarity: 2.5 kV Between the terminals of different polarity: 4 kV Between each terminal and non-live part: 6 kV
Insulation resistance	≥ 100 MΩ (500 VDC= megger)
Contact resistance	≤ 100 mΩ
Electrical life cycle	≥ 100,000 operations (250 VAC~/6 A)
Conditional short-circuit current	100 A
Solenoid	
Rated voltage	24 VDC=, class 2
Current consumption	Supplying power: 0.26A Normal: max. 0.2A (approx. 3 seconds after supplying power)
Insulation class	Class E
Indicator LED	
Rated voltage	24 VDC=
Current consumption	2.2 mA

Ensuring Stable and
Reliable Safety

Safety Non-Contact Door Switches

SFN Series

The SFN series safety non-contact door switches utilize magnetic type detection to monitor opening and closing of doors. The dedicated controller allows multiple connection of up to 30 units. The switches can be installed vertically or horizontally, and can also be installed from both sides which allow application in various types of doors.

Safety Standards

IEC/EN 60947-5-3
IEC/EN 61000-6-2/4
EN ISO 14119

Certifications





Easy Expansion

Up to 30 SFN series units can be connected to a single dedicated controller, and various connection types and connectors are available for easy expansion.

1. Connect Up to 30 Units

Connect up to 30 units to a single dedicated controller to save cost and installation time.

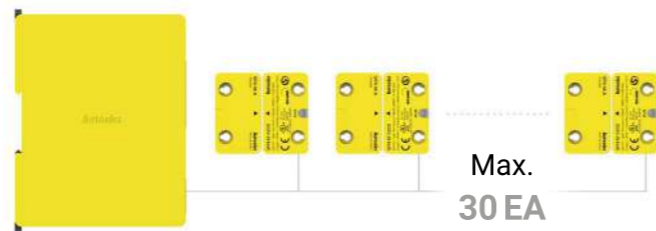

2. Two Connection Types

Users can select between cable type and cable connector type models depending on user requirements.



3. Various Connectors

The cable connector type models can be connected to various connectors and extension cables for flexible installation and maintenance.



Y-Shaped

Cross Shaped

Loop Connector

Flexible Installation

The units can be installed in right/left, front/rear, and top/bottom directions, allowing flexible installation in various door types.



Sliding Door



Swinging Door



Removable Cover Doors

Operation Indicator

The U-shaped operation indicator allows users to identify operation status from various directions.



IP67 Protection Rating

IP67 protection structure allows stable and error-free operation even in wet or dusty environments.



Non-contact Door Switches

SFN Series

Technical Overview

Ordering Information

This is only for reference. For selecting the specific model, follow the Autonics web site.



① Sensing method

M: Magnetic

② Cable

020: Cable type (2 m)

050: Cable type (5 m)

W: Cable connector type (M12, 0.3 m)

Dimensions

Unit: mm, For the detailed dimensions of the product, follow the Autonics web site.

■ Cable Type

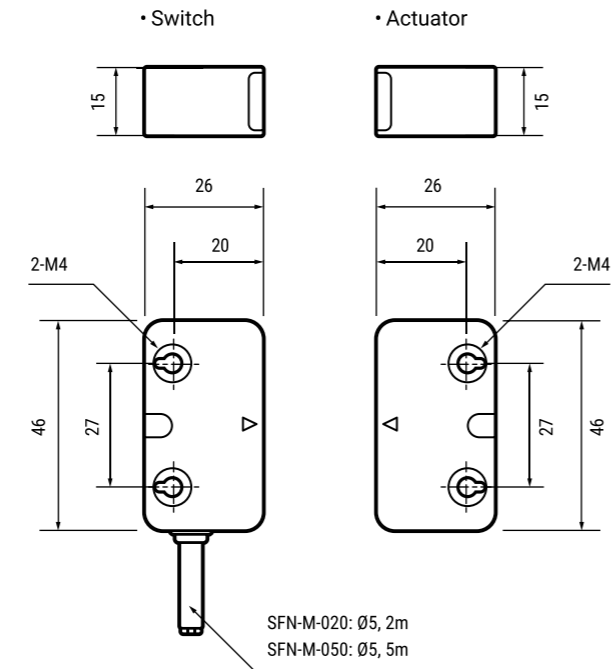

■ Cable Connector Type

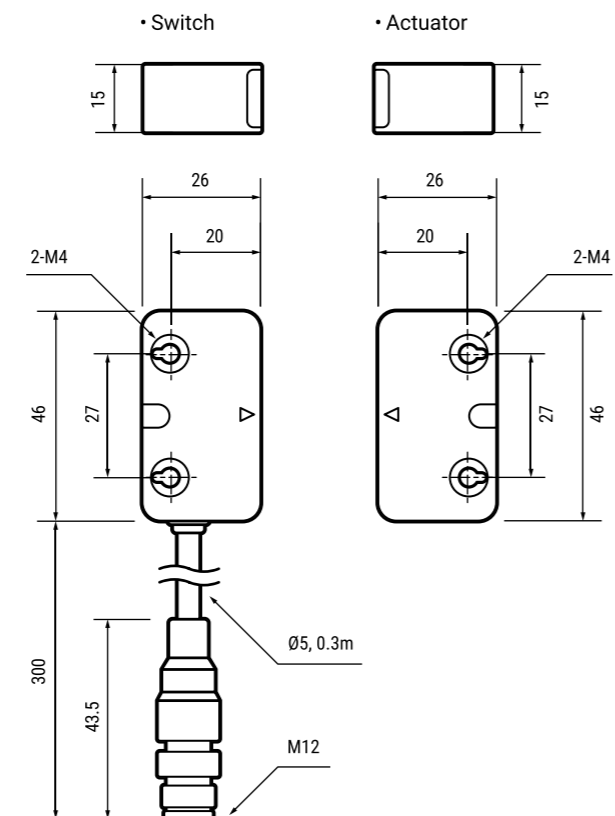

Specifications

Model	SFN-M-□
Operating distance⁰¹⁾	OFF→ON ≥ 5 mm ON→OFF ≤ 15 mm
Approval	CE (TUV NORD) (UL) (VDE) (S)
Unit weight (packaged)	Cable type (2 m): ≈ 100.5 g (≈ 113.8 g), Cable type (5 m): ≈ 199.5 g (≈ 214.8 g), Cable connector type: ≈ 58.1 g (≈ 71.6 g)
01) It is rated at 23°C of ambient temperature, and it may be differed up to ± 20 % by ambient temperature.	
Power supply	24 VDC (± 10 %)
Operating frequency	100 Hz
Power consumption⁰¹⁾	≤ 0.8 W
Auxiliary output	PNP open collector output - 24 VDC, 10 mA
Operation indicator	ON: green, OFF: red
Life expectancy	≥ 20,000,000 times (with low load)
Insulation resistance	≥ 50 MΩ (500 VDC, megger)
Protection circuit	Surge protection circuit, output short over current protection circuit, reverse polarity protection circuit
Dielectric strength	1,500 VAC ~ 50/60Hz for 1 minute
Vibration	1.0 mm amplitude at frequency of 10 to 55 Hz (for 1 min) in each X, Y, Z direction for 2 hours
Vibration (malfunction)	1.0 mm amplitude at frequency of 10 to 55 Hz (for 1 min) in each X, Y, Z direction for 10 min
Shock	300 m/s ² (≈ 30 G) in each X, Y, Z direction for 3 times
Shock (malfunction)	300m/s ² (≈ 30G) in each X, Y, Z direction in output ON/OFF status for 3 times
Ambient temperature	-10 to 55 °C, storage: -20 to 60 °C (no freezing or condensation)
Ambient humidity	35 to 85 %RH, storage: 35 to 85 %RH (no freezing or condensation)
Protection structure	IP67 (IEC standard)
Connection	Cable type / cable connector type model
Cable	Ø 5 mm, 5-wire, cable type: 2 m / 5 m, cable connector type: 0.3 m
Wire	AWG26 (0.08 mm), 28-core, core diameter: Ø 0.74 mm
Connector spec.	M12 plug connector
Material	Body/CAP: PC

01) Power to the load is not included.

Characteristic level / Safety category (with SFC-N322)	IEC 61508 SIL 3, IEC 62061 SIL CL 3, ISO 13849-1 PLe Cat.4 - HFT = 1, - Diagnostic Coverage : 99 % (high), - MTTFd = 100 year (high) - Mission time = 20 year, - PFH = 3.88E-09
---	---

Safety status in case of error: the switch does not have an internal error recognition function, so it can not maintain a safety status in the event of error.
Error recognition is processed in the connected controller (SFC-N322).

Connection examples

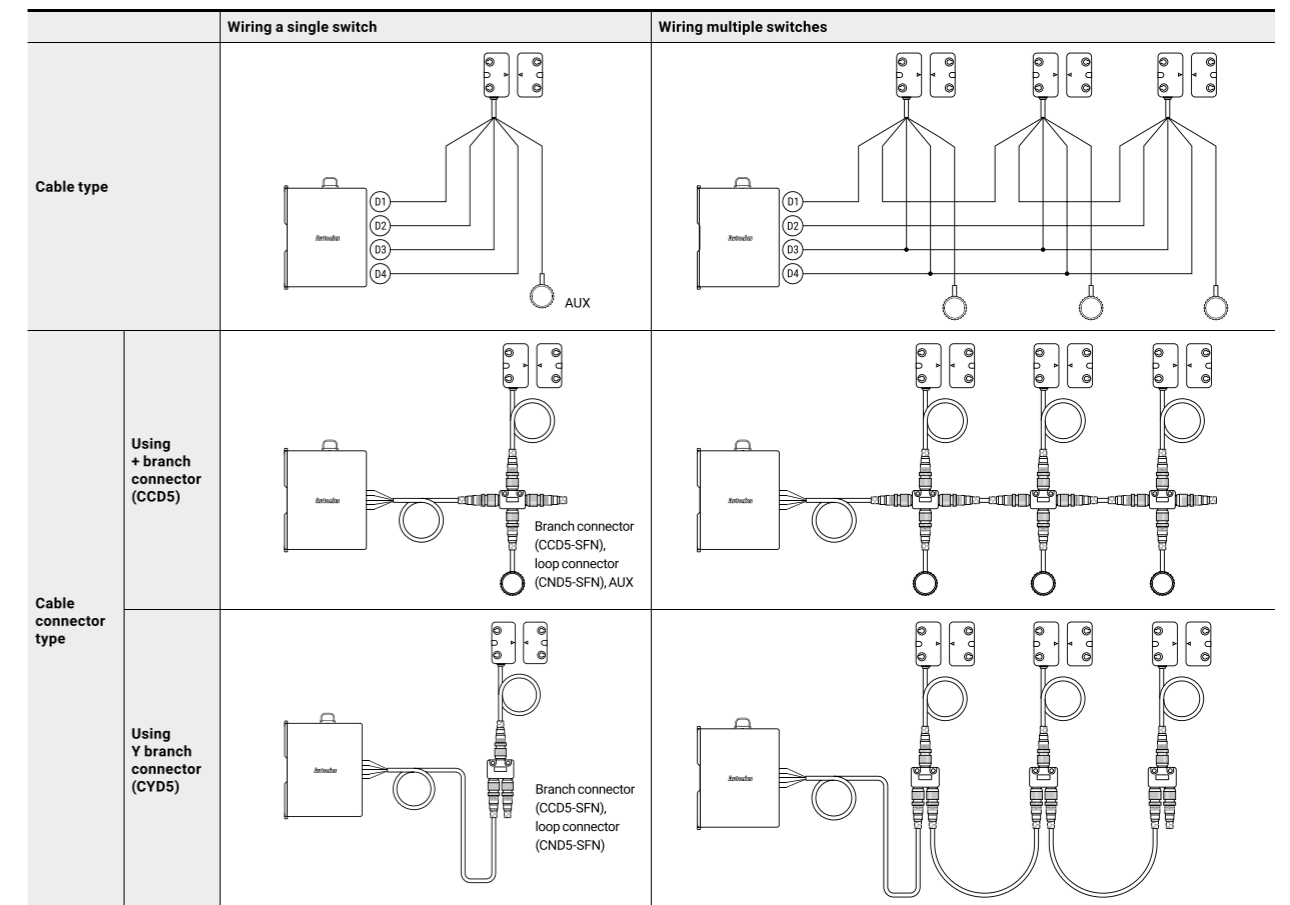

*Maximum 30 unit of switches can be connected to a controller (SFC-N322).

One Stop Solution for Your Safety Emergency Stop Button Switches

SF2ER Series

The SF2ER series emergency stop button switches are used to stop operation of machines during emergency situations and prevent injuries or hazards. The switches are push-lock / turn-reset methods and are available in D30 or D40 head sizes.

Safety Standards

IEC/EN 60947-5-1/5
EN ISO 13850
GB/T 14048.5

Certifications



4 Models Types

D30 and D40 head size models are available.

User can select from various models based on the type of operation.



D30



D40



D40-EMS

(Emergency Machine Stop)



D40-EMO

(Emergency Machine Off)

Mesh Contact with Sliding Structure

SF2ER series uses mesh contacts to increase contact points. The sliding structure removes oxide layers while making contact, allowing prolonged use without contact deterioration.

Nameplates

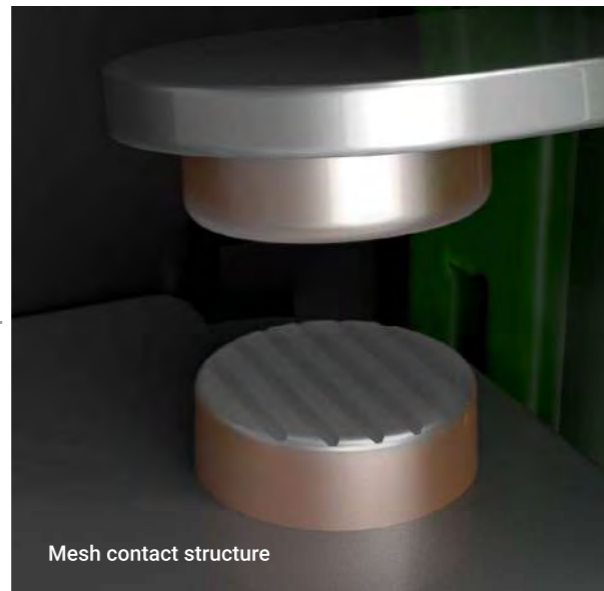

Mesh contact structure

Easy Terminal Connection

The switches are compatible with both O type and Y type terminals. The bolt plate ensures that the connection is made properly at a fixed position.

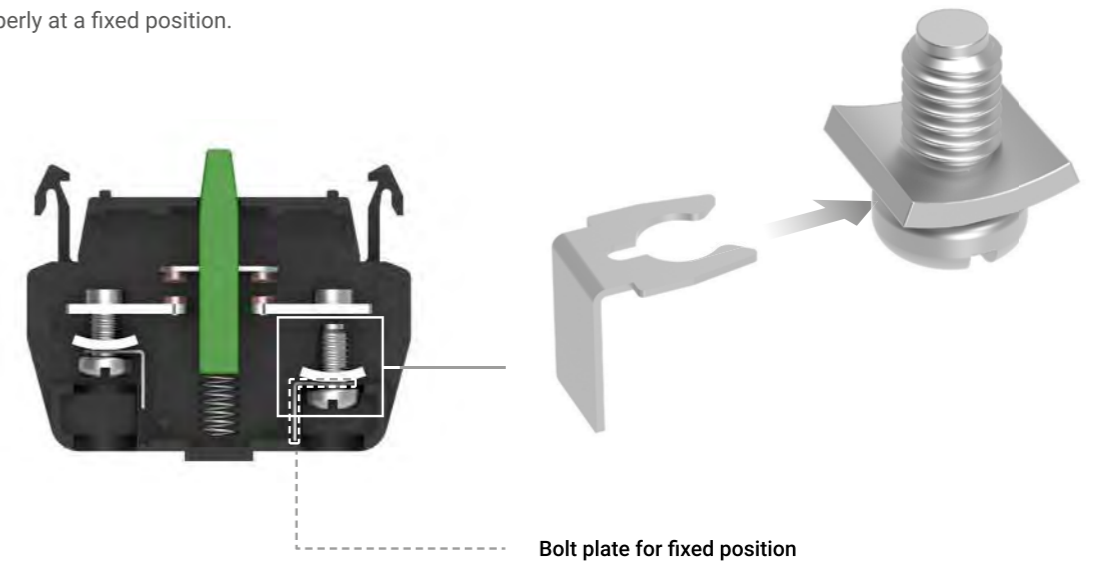

Bolt plate for fixed position





Various Accessories (Sold Separately)

Various accessories are available, including guard rings, nameplates, and radial support.



Guard ring

Standard type	Circle type	Lock type	Metal type	Embedded type (no spacer)	Embedded type (spacer×1)	Embedded type (spacer×2)
 Color: ○○	 Color: ○○	 Color: ○	 Color: ○	 Color: ○	 Color: ○	 Color: ○
GUARD-SF2ER(W)	GUARD2-SF2ER(W)	This guard ring is sold only as protection guard ring + name plate set. ※ single metal latch sold separately: GUARD3-SF2ER-L	GUARD2-SF2ER-M	GUARD4-SF2ER	GUARD41-SF2ER	GUARD42-SF2ER



Name plate

Ø 90, STOP	Ø 90, OFF	Ø 60, STOP	Ø 60, OFF
			
SF2ER-B	SF2ER-B2	SF2ER-B3	SF2ER-B4

Radial support

Rubber packing	Radial support
	
BK-SF2ER-RP	BK-SF2ER-P

Contact block

A contact (Normally Open)	B contact (Normally Closed)
	
SFEA-CA	SFEA-CB

Emergency Stop Switches

SF2ER Series

Technical Overview

Ordering Information

This is only for reference. For selecting the specific model, follow the Autonics web site.

SF2ER - E ① R ② - ③

① Button

- 1: D30 (short head, non-illuminated)
- 2: D40 (short head, non-illuminated)

② Contact block

- B: B contact: 1
- AB: A contact: 1, B contact: 1
- 2B: B contact: 2
- A2B: A contact: 1, B contact: 2
- 3B: B contact: 3

③ Mark

- No-mark: No-mark
- A: EMO
- S: EMS

Dimensions

Unit: mm, For the detailed dimensions of the product, follow the Autonics web site.

■ D30 (short head, non-illuminated)

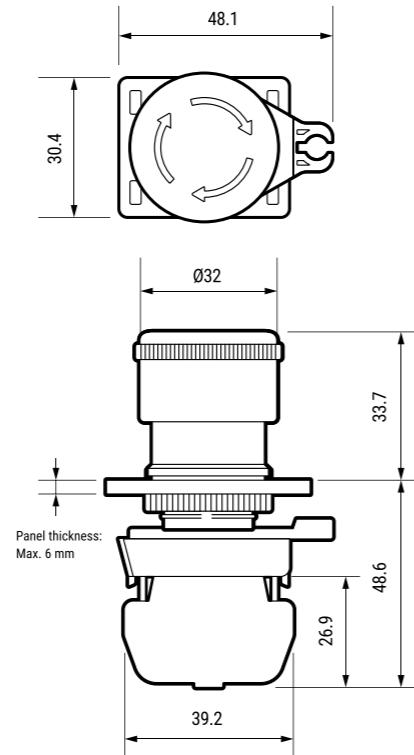

■ D40 (short head, non-illuminated)

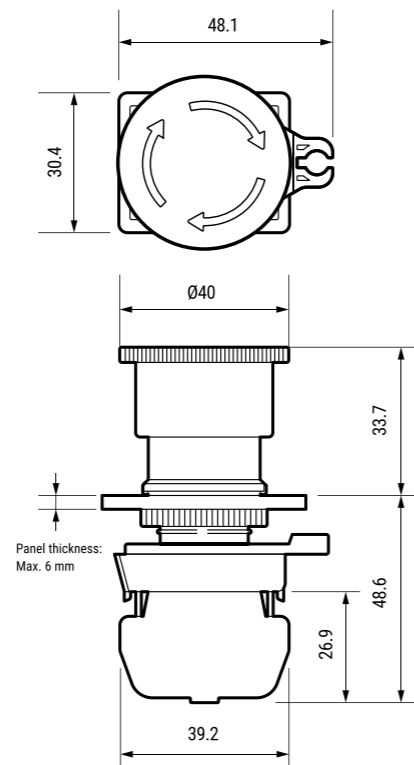

■ Panel cut-out

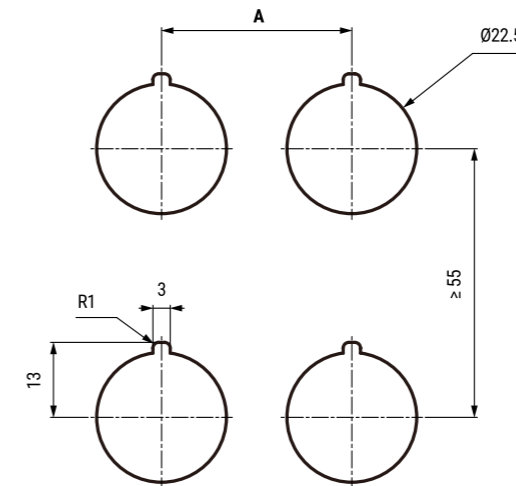

	A
D30	≥ 33 mm
D40	≥ 55 mm

Specifications

Model	SF2ER-□□□□□□
Rated voltage/current	IEC: AC-15 (220 VAC~, 3 A), DC-13 (220 VDC=, 0.2 A) UL: A300, Q300
Contact operating power	3.0 to 8.0 W / 1 contact
Operation distance	5.0 mm (0/-0.5)
Rotation angle	CW (clock wise) 52°
Allowable operation frequency ⁰¹⁾	Mechanical: 20 times/minute Electrical: 20 times/minute
Life cycle	Mechanical: Min. 250,000 times Electrical: Min. 100,000 times
Applicable wire	AWG 18 (0.823 mm ²)
Insulation resistance	≥ 100 MΩ (500 VDC= megger)
Dielectric strength	2,500 VAC~ 50/60 Hz for 1 minute
Vibration	1.5 mm double amplitude at frequency of 10 to 55 Hz (for 1 min) in each X, Y, Z direction for 2 hours
Vibration (malfunction)	1.5 mm double amplitude at frequency of 10 to 55 Hz (for 1 min) in each X, Y, Z direction for 10 minutes
Shock	1,000 m/s ² (≈ 100 g) in each X, Y, Z direction for 3 times
Shock (malfunction)	250 m/s ² (≈ 25 g) in each X, Y, Z direction for 3 times
Ambient temperature	-20 to 65°C ⁰²⁾ , storage: -40 to 70°C (at no freezing or condensation)
Ambient humidity	35 to 85 %RH, storage: 35 to 85 %RH (at no freezing or condensation)
Protection structure	IP65 ⁰³⁾ (oil resistant, IEC standards)
Material	Button: PC, BODY: PA6, lever in fixing unit: PA6
Approval	CE, TÜV, UL, S
Weight ⁰⁴⁾	≈ 66g

01) Setting and resetting once is counted as one operation.

02) UL approved ambient temperature: 55°C.

03) It is only for part from front of the panel. Protection structure is guaranteed only when the switch is installed on flat and smooth surface with mounting holes Ø22 mm.

04) It is switch with three contact blocks.

Contact capacity

• IEC (EN60947-5-1)

Rated current	10 A				
Rated voltage	24 V	110 V	220 V	380 V	
AC	Resistive load (AC-12)	10 A	10 A	6 A	3 A
	Inductive load (AC-15)	10 A	5 A	3 A	2 A
DC	Resistive load (DC-12)	10 A	2 A	0.6 A	0.2 A
	Inductive load (DC-13)	1.5 A	0.5 A	0.2 A	0.1 A

• UL / CSA (UL508, CSA C22.2 No. 14)

A300

Rated voltage	Through current	Current (A)		Volt ampere (VA)	
		Making	Breaking	Making	Breaking
AC120 V	10 A	60	6	7,200	720
AC240 V		30	3		

Q300

Rated voltage	Through current	Current (A)		Volt ampere (VA)	
		Making	Breaking	Making	Breaking
DC125 V	2.5 A	0.55	0.55	69	69
DC250 V		0.27	0.27		

Guard ring + Name plate set (Sold Separately)

Guard ring	Name plate	Model
Standard type	Ø 60, STOP	GUARD-SF2ER-S
	Ø 60, OFF	GUARD-SF2ER-A
Standard type white	Ø 60, STOP	GUARD-SF2ER-S-W
Circle type	Ø 60, STOP	GUARD2-SF2ER-S
	Ø 60, OFF	GUARD2-SF2ER-A
Circle type white	Ø 60, STOP	GUARD2-SF2ER-S-W
Lock type	Ø 60, STOP	GUARD3-SF2ER-S
	Ø 60, OFF	GUARD3-SF2ER-A
Metal type	Ø 60, STOP	GUARD2-SF2ER-S-M
	Ø 60, OFF	GUARD2-SF2ER-A-M



Additional Safety for
Operation Control

Grip Type Enabling Switches

SFEN Series

The SFEN series safety grip type enabling switches can be used to manually control operation within a hazardous area during maintenance in order to prevent personal injury in the event of unexpected machine operation.

The switches feature high operation sensitivity and various lineup models for diverse applications.

Safety Standards

IEC/EN 60947-5-1

IEC/EN 60947-5-8

GB/T 14048.5

Certifications



Various Model Lineup

Enabling switches are available in various models including standard, ø16 stop button and momentary button types for diverse user applications.



Standard Type
SFEN Series



Stop button type
SFEN-B Series



Momentary button type
SFEN-M Series



High Operation Sensitivity with 3-Position Snap Action

Enabling switches offer high operation sensitivity with 3-position snap action and the ergonomic design allows easy single-hand operation.

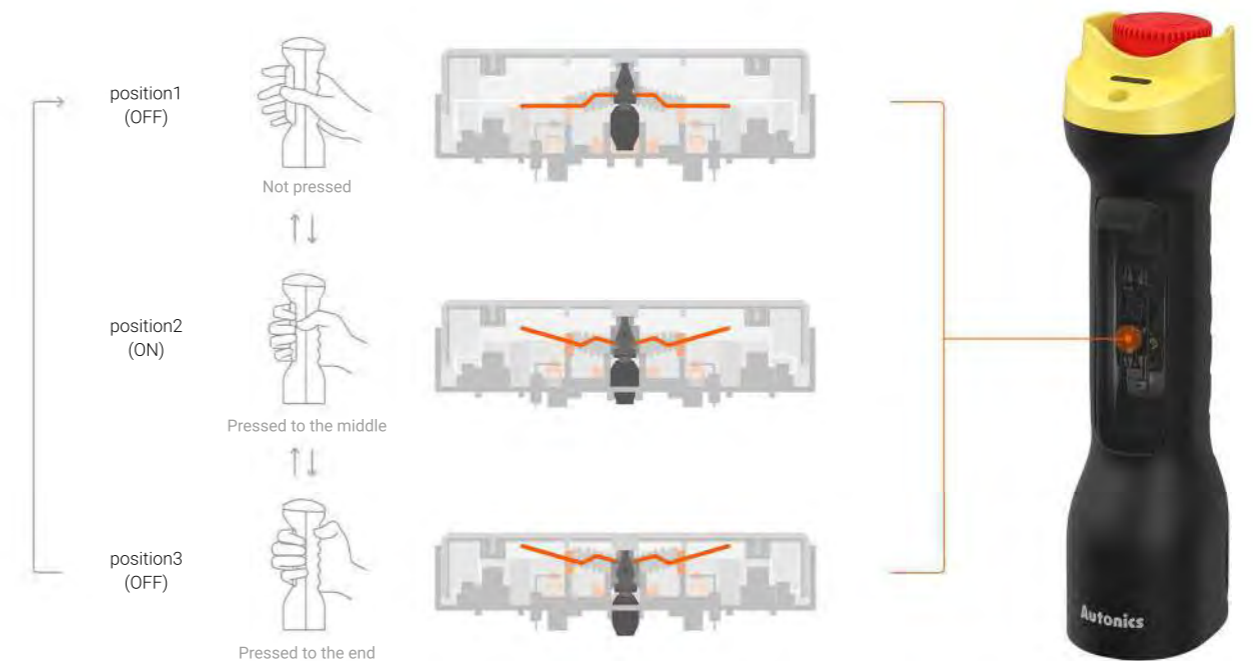

Operation Indicator

The operation indicator (green LED) allows users to easily identify operation status.



Grip Type Enabling Switches

SFEN Series

Technical Overview

Ordering Information

This is only for reference. For selecting the specific model, follow the Autonics web site.



1 Type

No mark: Standard type	B: Stop button type	M: Momentary button type

Dimensions

Unit: mm, For the detailed dimensions of the product, follow the Autonics web site.

A	Enable operation indicator (green)	B	Cable grand
C	Push button B	D	Push button A

SFEN

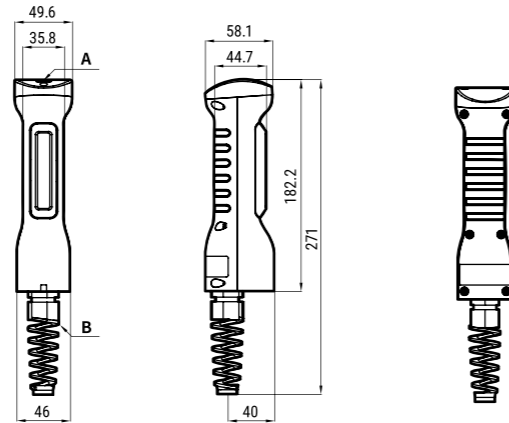

SFEN-B

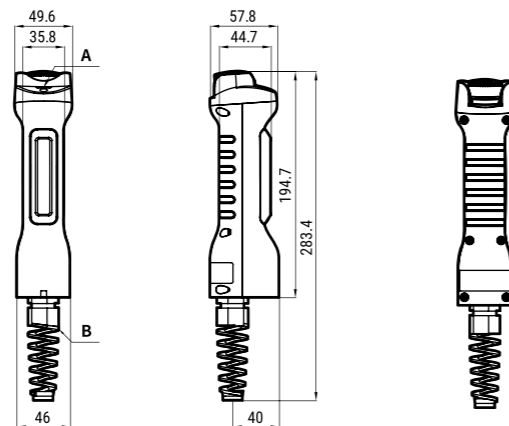

SFEN-M

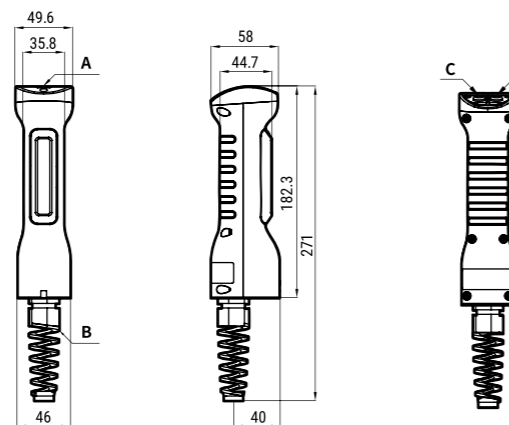

Specifications

• Enable switch

Rated Insulation Voltage	250 VAC~
Rated through current	2.5 A
Rated inductive load	AC-15 (0.75 A / 240 VAC~), DC-13 (0.55 A / 125 VDC=)
Rated resistive load⁽¹⁾	0.75 A / 240 VAC~, 0.55 A / 125 VDC=
Controller strength⁽²⁾	Operation direction: 200 N, for 1 min
Operating frequency	Electrical: ≤ 20 / min, Mechanical: ≤ 20 / min
Dielectric strength	Between terminals of same polarity, between terminals of different polarity, between terminal and non-live part : 2,500 VAC~ 50 / 60 Hz for 1 min (impulse dielectric strength)
Electrical life cycle	≥ 100,000 operations (rated load)
Mechanical life cycle	OFF → ON → OFF: ≥ 100,000 operations / OFF → ON: ≥ 1,000,000 operations

01) Use a 10 A fuse gl or gG conforming to IEC60269 as short-circuit protection. The body does not have a built-in fuse.
02) Do not use the switch more than the controller strength. Failure to follow this instruction may result in product damage.

• Enable switch

Rated Insulation Voltage	250 VAC~
Rated through current	3 A
Rated resistive load⁽¹⁾	AC-12 (3 A / 250 VAC~), DC-12 (3 A / 30 VDC=)
Controller strength⁽²⁾	Operation direction: 400 N, for 1 min (operation direction: 0.5 N m, for 1 min)
Operating frequency	Electrical: ≤ 10 / min, Mechanical: ≤ 10 / min
Dielectric strength	Between terminals of same polarity, 1,000 VAC~ 50 / 60 Hz for 1 min, between terminals of different polarity, between terminal and non-live part : 2,000 VAC~ 50 / 60 Hz for 1 min.
Electrical life cycle	≥ 100,000 operations (rated load) (Push / Release 1 time)
Mechanical life cycle	≥ 100,000 operations (Push / Release 1 time)

01) Use a 10 A fuse gl or gG conforming to IEC60269 as short-circuit protection. The body does not have a built-in fuse.
02) Do not use the button more than the controller strength. Failure to follow this instruction may result in product damage.

• Momentary button

Rated Insulation Voltage	125 VAC~
Rated through current	0.1 A
Rated resistive load⁽¹⁾	AC-12 (0.1 A / 125 VAC~), DC-12 (0.1 A / 30 VDC=)
Controller strength⁽²⁾	Operation direction: 10 N, for 1 min
Operating frequency	Electrical: ≤ 25 / min, Mechanical: ≤ 60 / min
Dielectric strength	Between terminals of same polarity: 600 VAC~ 50 / 60 Hz for 1 min, between terminals of different polarity, between terminal and non-live part : 1,000 VAC~ 50 / 60 Hz for 1 min.
Electrical life cycle	≥ 100,000 operations (rated load)
Mechanical life cycle	≥ 1,000,000 operations

01) Use a 10 A fuse gl or gG conforming to IEC60269 as short-circuit protection. The body does not have a built-in fuse.
02) Do not use the button more than the controller strength. Failure to follow this instruction may result in product damage.

Common spec.

Conditional short circuit current	100 A
Min. applied load	DC24 V 4 mA
Directing opening force	30 N ± 10
Directing opening distance	4.8 mm ± 0.5
Insulation resistance	≥ 100 MΩ (500 VDC= megger)
Vibration (malfunction)	1.5 mm double amplitude at frequency of 10 to 55 Hz (for 1 min) in each X, Y, Z direction for 10 min
Shock (malfunction)	150 m/s ² (≈ 15 G) in each X, Y, Z direction for 3 times
Ambient temperature	-10 to 55 °C, storage: -25 to 65 °C (no freezing or condensation)
Ambient humidity	35 to 85 %RH, storage: 35 to 85 %RH (no freezing or condensation)
Insulation class	Class II (double insulation)
Indicator	Enable operation indicator (green)
Protection structure	SFEN: IP66 (IEC standard) SFEN-B, SFEN-M: IP65 (IEC standard)
Applicable wire	AWG 20 to 18 (0.5 to 0.75 mm ²)
Connection type	M20 connector cable grand
Material	Cover: PA66, button: PC, rubber grip: Silicone
International standards	IEC 60947-5-1, IEC 60947-5-8, UL 60947-5-1
Approval	CE (TUV NORD)
Unit weight (package)	SFEN: ≈ 238 g (≈ 363 g) SFEN-B: ≈ 268 g (≈ 388 g) SFEN-M: ≈ 252 g (≈ 376 g)

Contact composition

	SFEN	SFEN-B	SFEN-M
Enable switch	2 N.O.	2 N.O.	2 N.O.
Option output	1 N.C.	-	-
Stop button	-	2 N.C.	-
Momentary button	-	-	2 N.O.



Flexible System Configuration

Key Selector Switches

SF2KR Series

The SF2KR series safety key selector switches are installed in safety fences or industrial equipment doors to control operation of machines, offering additional safety during maintenance in potentially dangerous environments.

Safety Standards

IEC/EN 60947-5-1

GB/T 14048.5

Certifications



Ensure Additional Safety with Shared Key

The same key can be used with other key selector switches within or outside the fence, offering additional safety. Operators can enter potentially dangerous areas while possessing the key, preventing key loss or entrapment within the hazardous area.

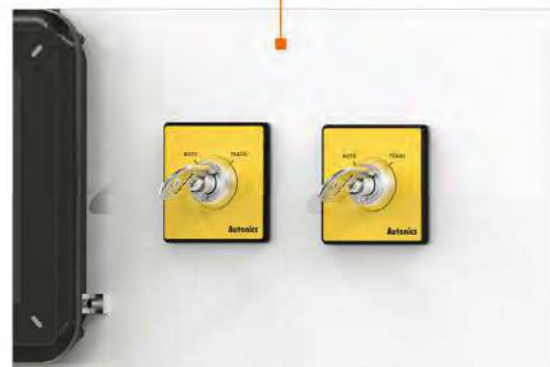

※ Inside the fence (SF2KR-□)
Outside the fence (SF2KR-M□)

240 Different Models Available

The switches are available in various models including 4 types of key release direction, 3 types of N.C. contact powered location, and 10 types of keys depending on the general/lockable models for diverse applications.

Key lock function	Key free location	N.C. contact powered location	Lock location	Contact block	Key
General type	↖	↖	-	N.O.1 + N.C.2 N.C.3 N.O.2 + N.C.2	No mark: Basic key 01 to 09: Key number 1 to 9
	↗	↖	-		
	↘	↗	-		
Lockable type	↗	↖	↗		
	↘	↗	↗		
	↘	↖	↗↖		

Key Lock Function Available

Key selector switches are available in single direction and bi-directional lock types with mechanical/solenoid release methods, preventing unintended mode switching during maintenance.



Front Operation Indicator

Front operation indicator (green LED) allows users to easily identify solenoid operation status.

※ Lock type models only: SF2KR-M□



Key Selector Switches

SF2KR Series

Technical Overview

Ordering Information

This is only for reference. For selecting the specific model, follow the Autonics web site.



① Key lock function

No mark: General type
M: Lockable type

② Operation direction

General type

	Key free location	N.C. contact powered location
LL	↙	↙
RL	↗	↗
LR	↙	↗
RR	↗	↙

Lockable type

	Key free location	N.C. contact powered location	Lock location
RLR	↗	↙	↗
RLL	↗	↙	↙
RRR	↗	↗	↗
RLB	↗	↙	↗↙

③ Contact block

A2B: N.O. 1 + N.C. 2
3B: N.C. 3
2A2B: N.O. 2 + N.C. 2

④ Key

No mark: Basic key
01 to 09: Key number 1 to 9

Dimensions

Unit: mm, For the detailed dimensions of the product, follow the Autonics web site.

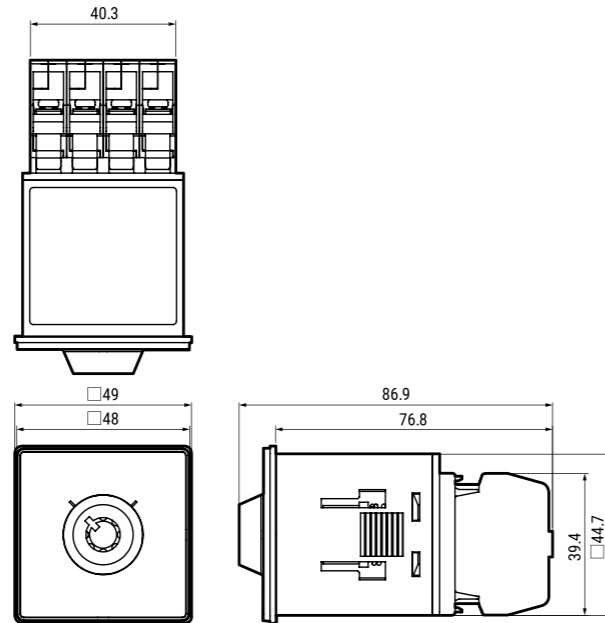

■ Bracket

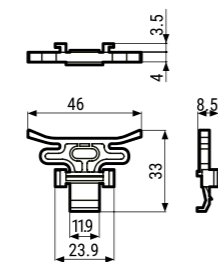

■ Panel cut-out

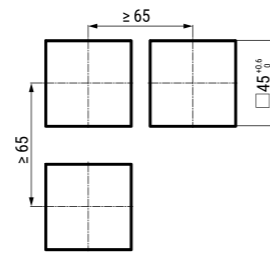

Specifications

Model	SF2KR-□-□-□	SF2KR-M□-□-□
Solenoid input voltage	-	Non-polar 24 VDC± (± 10%)
Solenoid current consumption	-	38.7 mA ± 5%
Conditional short circuit current	100 A	
Indicator	-	Solenoid operation (green)
Applicable wire	Contact: AWG 18 (0.823 mm ²)	Solenoid power: AWG 24 - 18 Contact: AWG 18 (0.823 mm ²)
Allowable operation frequency ⁰¹⁾	30 times/minute	
Life cycle	Mechanical: ≥ 100,000 times, electrical: ≥ 100,000 times	
Key pushing force	≥ 20 N	
Key rotating torque	0.2 to 1.8 N·m	
Insulation resistance	≥ 100 MΩ (500 VDC≒ megger)	
Dielectric strength	2,500 VAC~ 50/60 Hz for 1 minute	
Vibration	1.5 mm double amplitude at frequency of 10 to 55 Hz (for 1 min) in each X, Y, Z direction for 2 hours	
Vibration (malfunction)	1.5 mm double amplitude at frequency of 10 to 55 Hz (for 1 min) in each X, Y, Z direction for 10 minutes	
Shock	300 m/s ² (≈ 30 g) in each X, Y, Z direction for 3 times	
Shock (malfunction)	150 m/s ² (≈ 15 g) in each X, Y, Z direction for 3 times	
Ambient temperature	-20 to 70°C ⁰²⁾ , storage: -40 to 70 °C (at no freezing or condensation)	-10 to 55°C ⁰²⁾ , storage: -20 to 70 °C (at no freezing or condensation)
Ambient humidity	35 to 85%RH, storage: 35 to 85%RH (at no freezing or condensation)	
Protection structure	IP65 (front panel, IEC standard)	
Material	PC, POM	
Approval	CE (TUV NORD) Ⓢ Ⓜ Ⓝ	
Unit weight (packaged) ⁰³⁾	≈ 130 g (≈ 192 g)	≈ 152 g (≈ 213 g)

01) Rotating and returning once is counted as one operation.
02) UL approved ambient temperature: 55 °C
03) It is switch with contact blocks.

■ Contact capacity

• IEC (EN60947-5-1)

Rated current	10 A				
Rated voltage	24 V	110 V	220 V	380 V	
AC	Resistive load (AC-12)	10 A	10 A	6 A	3 A
	Inductive load (AC-15)	10 A	5 A	3 A	2 A
DC	Resistive load (DC-12)	10 A	2 A	0.6 A	0.2 A
	Inductive load (DC-13)	1.5 A	0.5 A	0.2 A	0.1 A

• UL / CSA (UL508, CSA C22.2 No. 14)

A300

Rated voltage	Through current	Current (A)		Volt ampere (VA)	
		Making	Breaking Making	Making	Breaking Making
AC120 V	10 A	60	6	7,200	720
AC240 V		30	3		

Q300

Rated voltage	Through current	Current (A)		Volt ampere (VA)	
		Making	Breaking Making	Making	Breaking Making
DC125 V	2.5 A	0.55	0.55	69	69
DC250 V		0.27	0.27		



Take Control of Your Safety Safety Controllers

SFC/SFC-R Series

The SFC series safety controllers are used together with safety input devices (switches, sensors, etc.) to provide safe working environments. The controllers feature self-diagnosis function and safety integrity to meet international safety standards.

Safety Standards

- IEC/EN 61508 (SIL 3)
- IEC/EN 62061 (SIL CL 3)
- ISO 13849-1/2 (Cat. 4, PL e)
- IEC/EN 60947-5-1 (SRC-R)
- IEC/EN 61000-6-2/4 (SFC, SFC-A/N)
- EN 50178

Certifications



Various User-Friendly Features

The SFC series features various user-friendly features including slim size, operation indicators, front facing terminals, multiple logic inputs and more.

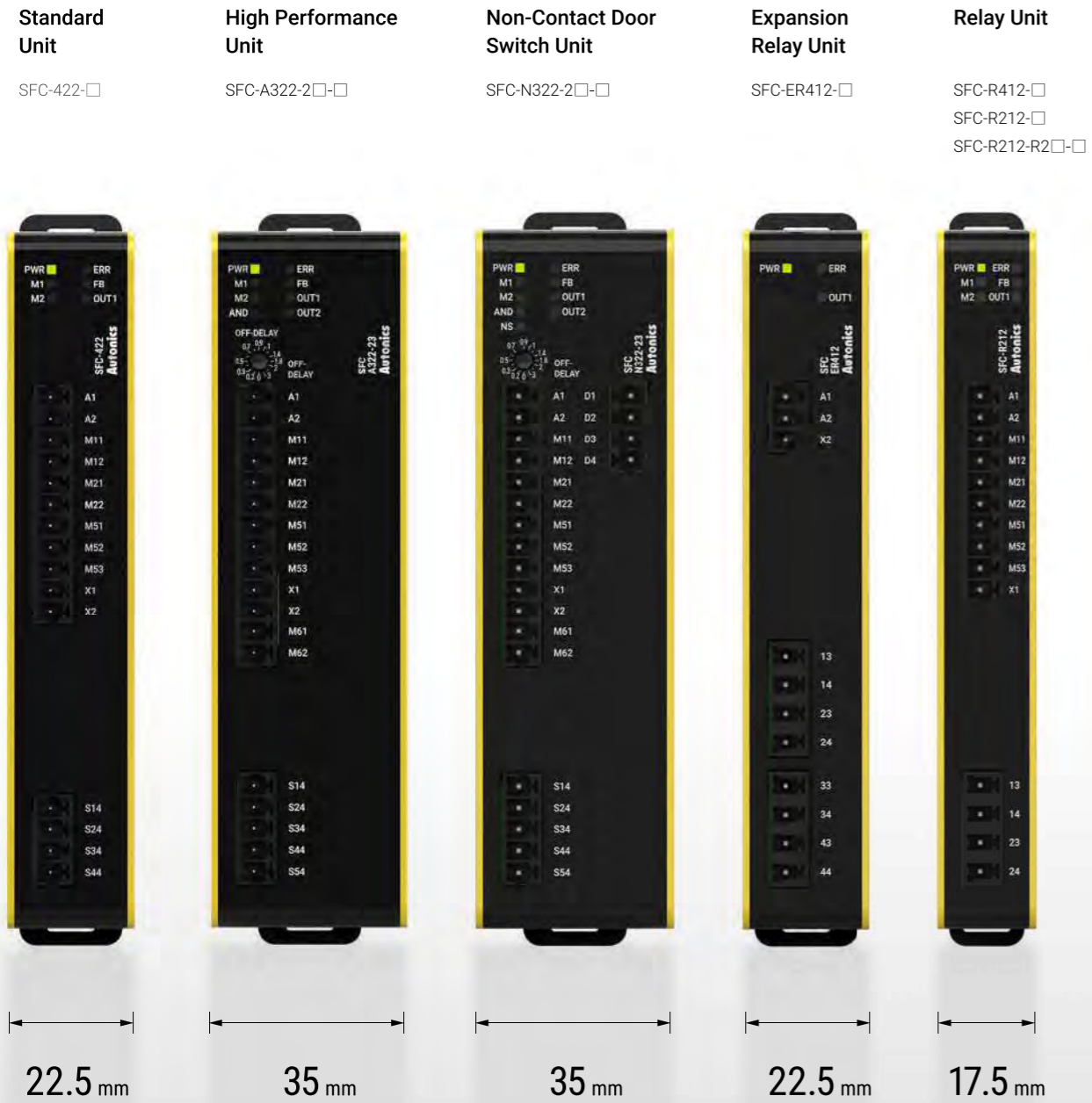

1. Slim Space-Saving Design

The slim space-saving design (minimum width 17.5 mm) allows flexible installation in tight or limited spaces.

2. Operation Indicators

Users can easily check various operation and connection status with the operation indicators.



3. Front Terminal Design

Socket type terminal is located on the front for easy wiring and maintenance.



4. 16-Level Time Setting

The OFF-delay output models allow up to 16 different OFF-delay time settings.

* Available models : 0 to 3 s / 0 to 30 s / 0 to 300 s

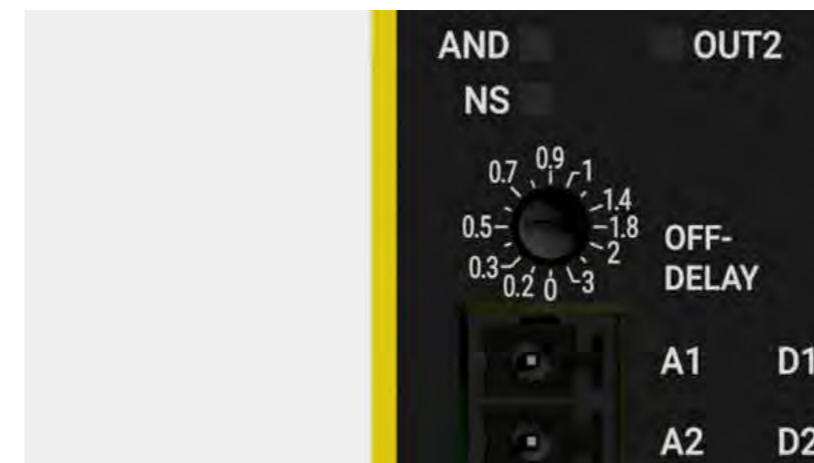

Safety-Oriented Product Design

The SFC series utilizes force guided contact relays to protect from contact welding and ventilation holes are present to reduce heating.



5. Flexible OFF-Delay Output

On high performance units (SFC-A) and non-contact door switch units (SFC-N), users can set to 1 instantaneous output and 4 OFF-delay outputs using the DIP switch (default: 3 instantaneous, 2 OFF-delay). Auxiliary output is also available to check various error status.

* 4 safety outputs are available on standard unit controllers.



6. Expansion Relay Unit

The expansion relay units (SFC-ER) can be connected to high performance units (SFC-A) and non-contact door switch units (SFC-N) to increase the number of relay type safety output. (Connect up to 5 expansion relay units per 1 controller)

7. Up to 20 Logic Inputs

The SFC series can be expanded up to 20 units using logic input offering wider control of safety devices. Safer operation is possible with multiple logic connections.

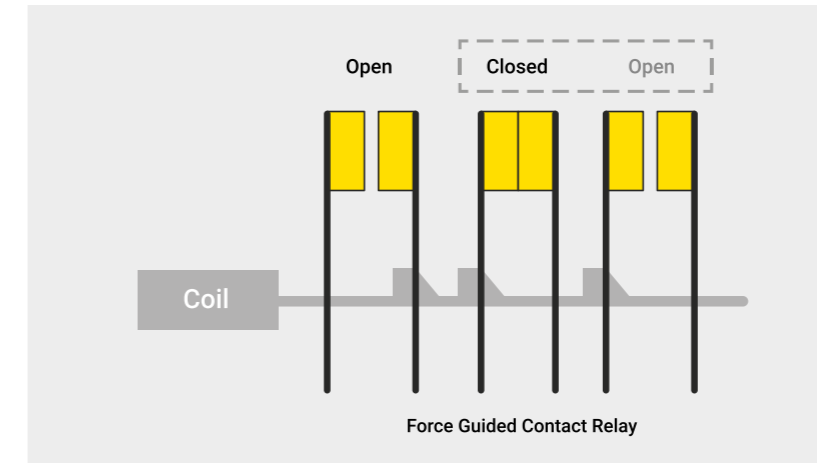

1. Safety Circuit Design

TUV SIL certified force guided contact relays are used to detect failures including contact welding and circuit damage.

* Contact welding: welding of contacts due to high inrush current or overload.



2. Ventilation Holes

Ventilation holes are located on the top and bottom of the product to reduce heating.

Controllers

SFC Series

Technical Overview

Ordering Information

This is only for reference. For selecting the specific model, follow the Autonics web site.

SFC - ① ② ③ ④ ⑤ ⑥ - ⑦

① Function

No-mark: Basic unit
 A: Advanced unit
 N: Non-contact door switch unit
 (for Autonics SFN Series)
 ER: Expansion relay unit
 R: Relay unit

② No. of safety instantaneous outputs

Number: Number of outputs

③ No. of auxiliary outputs

Number: Number of outputs

④ Off-delay output elements

No-mark: P channel FET
 R: Relay (Relay unit)

⑤ No. of Off-delay outputs

No-mark: None
 2: 2

⑥ Max. Off-delay time

Number: Time (unit: sec)

⑦ Terminal type

No-mark: Screw
 L: Screwless

Dimensions

Unit: mm, For the detailed dimensions of the product, follow the Autonics web site. The below is based on SFC-A (screw type) model.

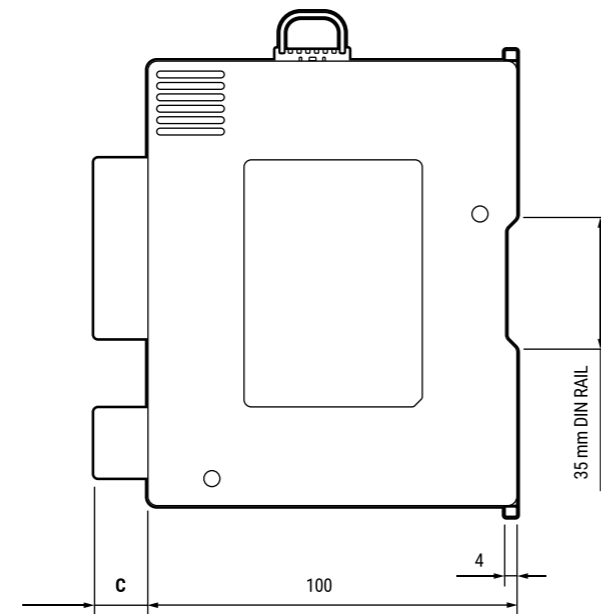

• Mounting with bolts

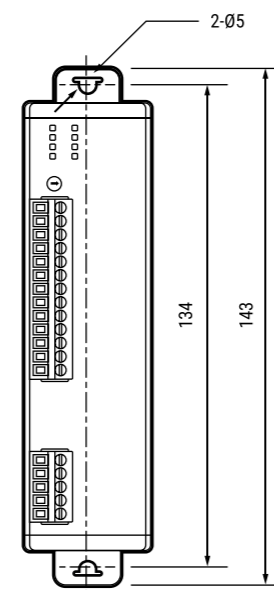

• Mounting on DIN rail

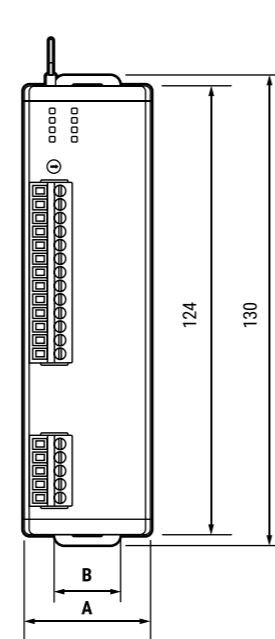

Model		A	B	C
Basic unit	SFC-422-□	22.5	18.3	Screw type: 15.3 Screwless type: 15.5
Advanced unit	SFC-A322-□□	35	18.3	
Non-contact door switch unit	SFC-N322-□□	35	18.3	
Expansion relay unit	SFC-ER412-□	22.5	18.3	
	SFC-R412-□	22.5	18.3	
Relay unit	SFC-R212-□	17.5	13.3	
	SFC-R212-R□□	22.5	18.3	

■ Panel cut-out

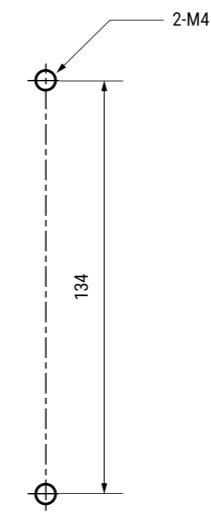

Specifications

Unit	Basic	Advanced	Non-contact door switch
Model	SFC-422-□	SFC-A322-□□	SFC-N322-□□
Power supply	24 VDC≒		
Allowable voltage range	85 to 110% of rated voltage		
Power consumption ⁰¹⁾	≤ 2.5 W	≤ 3.0 W	≤ 3.5 W
Input	ON: ≥ 11 VDC≒ ≥ 5 mA, OFF: ≤ 5 VDC≒ ≤ 1 mA		
Input time	≥ 50 ms, feedback start (manual) : ≥ 100 ms		
Cable	≤ 100 m (≤ 100Ω, ≤ 10nF)		
Safety output	P channel FET ⁰²⁾		
Instantaneous	4 X	3 X ⁰³⁾	3 X ⁰³⁾
Off-delay ⁰⁴⁾	-	2 X ⁰³⁾	2 X ⁰³⁾
Time accuracy	-	≤ ± 5%	≤ ± 5%
Load current	Below 2-point output: ≤ DC 1 A Over 3-point output: ≤ DC 0.8 A		
Leakage current	≤ 0.1 mA		
Operating time (OFF → ON) ⁰⁵⁾	Safety Input : ≤ 50 ms Logic input: ≤ 200 ms Non-contact door switch input: ≤ 100 ms		
Response (return) time (ON → OFF) ⁰⁵⁾	≤ 15 ms, non-contact door switch input or logic input: ≤ 20 ms		
Auxiliary output	2 × PNP transistor: X1, X2 (error)		
Load current	≤ 100 mA		
Leakage current	≤ 0.1 mA		
Approval	IEC/EN 61508 (SIL3), IEC/EN 62061 (SILCL3) IEC/EN 60947-5-1, EN ISO 13849-1 (Category 4, PLe) UL listed E249635		
Certification	CE		
Unit weight (package)	≈ 70 g (≈ 120 g)	≈ 90 g (≈ 140 g)	≈ 100 g (≈ 150 g)

01) Not include the power consumption of loads.
 (SFC-N exclude the power supplied to the non-contact door switch.)
 02) Includes a diagnostic pulse (max. 600 μs). Be cautious when using the output signal as an input signal for the control device.

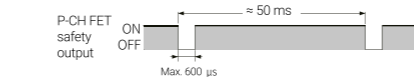

03) Available changing via setting switch on the back side of the product.
 04) Available to set Off-delay time (max. 3 sec. / 300 sec., depends on model)
 05) The operation (response) time of each model. The time increases when a logical connection or expansion relay unit is connected.

Unit	Expansion relay	Relay		
Model	SFC-ER412-□	SFC-R412-□	SFC-R212-□	SFC-R212-R2□□
Power supply	24 VDC≒			
Allowable voltage range	85 to 110% of rated voltage			
Power consumption ⁰¹⁾	≤ 2.5 W	≤ 4.0 W	≤ 4.0 W	≤ 6.0 W
Input	ON: ≥ 11 VDC≒ ≥ 5 mA, OFF: ≤ 5 VDC≒ ≤ 1 mA			
Input time	≥ 50 ms, feedback start (manual) : ≥ 100 ms			
Cable	≤ 100 m (≤ 100Ω, ≤ 10nF)			
Safety output	Relay			
Instantaneous	4 X	4 X	2 X	2 X
Off-delay ⁰²⁾	-	-	-	2 X
Time accuracy	-	-	-	≤ ± 5%
Capacity	240 VAC~ 5 A, 30 VDC≒ 5 A			
Life expectancy	Mechanical: ≥ 10,000,000 operations, Malfunction: ≥ 50,000 operations			
Contact resistance	≤ 100 mΩ			
Inductive load switching	IEC60947-5-1: AC15: 230V~ 3A, DC13: 24V≒ 3A, UL508: B300/R300			
Conditional short-circuit current	100 A ⁰³⁾			
Operating time (OFF → ON) ⁰⁴⁾	≤ 30 ms ⁰⁵⁾		≤ 100 ms	
Response (return) time (ON → OFF) ⁰⁴⁾	≤ 10 ms		≤ 15 ms	
Auxiliary output	1 × PNP transistor: X2 (error)		1 × PNP transistor: X1	
Load current	≤ 100 mA		≤ 100 mA	
Leakage current	≤ 0.1 mA			
Approval	CE			
Certification	IEC/EN 61508 (SIL3), IEC/EN 62061 (SILCL3) IEC/EN 60947-5-1, EN ISO 13849-1 (Category 4, PLe) UL listed E249635			
Unit weight (package)	≈ 100 g (≈ 150 g)	≈ 110 g (≈ 160 g)	≈ 80 g (≈ 130 g)	≈ 110 g (≈ 150 g)

01) Not include the power consumption of loads.
 02) Available to set Off-delay time (max. 3 sec. / 30 sec., depends on model)
 03) Use 6A fast-blow fuse under the IEC 60127 standard as a short-circuit protection device.
 04) The operation (response) time of each model. The time increases when a logical connection or expansion relay unit is connected.
 05) Except operation time of advanced unit, non-contact door switch unit

Pollution	3
Overvoltage category	III
Dielectric strength	Basic / Advanced / Non-contact door switch unit: 500 VAC~ 50/60 Hz for 1 min. (between all terminals and case) Expansion relay / relay unit: 1,500 VAC~ 50/60 Hz for 1 min. (between all terminals and case) 2,500VAC~ 50/60Hz, for 1 min. (between input terminals and output terminals)
Insulation resistance	≥ 100 MΩ (500 VDC≒ megger)
Vibration ⁰¹⁾	0.75 mm amplitude at frequency of 10 to 55 Hz (for 1 min) in each X, Y, Z direction for 1 hour
Vibration (malfunc.) ⁰¹⁾	0.5 mm amplitude at frequency of 10 to 55 Hz (for 1 min) in each X, Y, Z direction for 10 minutes
Shock ⁰¹⁾	300 m/s ² (≈ 30 G) in each X, Y, Z direction for 3 times
Shock (malfunc.) ⁰¹⁾	100 m/s ² (≈ 10 G) in each X, Y, Z direction for 3 times
Protection structure	IP20
Ambient temperature	-10 to 55 °C, storage: -25 to 65 °C (rated at no freezing or condensation)
Ambient humidity	25 to 85 %RH, storage: 25 to 85 %RH (rated at no freezing or condensation)

01) This data based on the product is mounted with bolts. When installing DIN rail, use the product in an environment with small vibration(condition: less than 0.4 mm double amplitude).

SAFETY.

SAFETY is the safety product brand of Autonics that protects workers from the risk of accidents in industry sites. In the brand design concept, the meaning of this safety protection is visualized using a square as a basic element.



Autonics

Products

Sensors, Controllers, Motion Devices, Safety, Measuring Equipment, Connection Equipment and more

- Safety Light Curtains • Safety Switches • Safety Controllers • Vision Sensors • LiDAR • Displacement Sensors
- Photoelectric Sensors • Photomicro Sensors • Fiber Optic Sensors • Door Sensors • Area Sensors • Proximity Sensors • Pressure Sensors
- Rotary Encoders • Temperature Controllers • Solid State Relays • Power Controllers • Counters • Timers
- Digital Panel Meters • Digital Display Units • Sensor Controllers • SMPS • Industrial PC • HMI's • Recorders • Indicators • Network Converters
- Closed Loop Stepper Motor System (Ai-SERVO) • 5-Phase Stepper Motor & Drivers • 2-Phase Stepper Motor Drivers
- Motion Controllers • Industrial Networking • I/O Terminal Blocks • Distribution Boxes • Cables
- Control Switches/Pilot Lights/Buzzers • Pressure Transmitters • Temperature Transmitters • Software

Global Network

Global Business Headquarters 39, Magokjungang 5-ro 1-gil, Gangseo-gu, Seoul, Republic of Korea, 07594
Tel: 82-2-2048-1577 / E-mail: sales@autonics.com

Brazil **Autonics do Brasil Comercial Importadora e Exportadora LTDA**
Tel: 55-11-2307-8480 / 3195-4610 / Fax: 55-11-2309-7784 / E-mail: comercial@autonics.com.br

China **Autonics electronic(Jiaxing) Corporation**
Tel: 86-573-8216-1900 / Fax: 86-573-8216-1917 / E-mail: china@autonics.com

India **Autonics Automation India Private Limited**
Tel : 91-22-2768-2570 / E-mail: india@autonics.net.in

Indonesia **PT. Autonics Indonesia**
Tel: 62-21-8088-8814/5 / E-mail: indonesia@autonics.co.id

Japan **Autonics Japan Corporation**
Tel: 81-3-6435-8380 / Fax: 81-3-6435-8381 / E-mail: ja@autonics.com

Malaysia **Mal-Autonics Sensor Sdn. Bhd.**
Tel: 60-3-7805-7190 / Fax: 60-3-7805-7193 / E-mail: malaysia@autonics.com

Mexico **Autonics Mexico S.A. DE C.V**
Tel: 52-800-523-2131 / E-mail: ventas05@autonics.com

Russia **Autonics Rus LLC**
Tel/Fax: 7-495-660-10-88 / E-mail : russia@autonics.com

Türkiye **Autonics Otomasyon Ticaret Ltd. Sti.**
Tel: 90-216-365-9117/3/4 / Fax: 90-216-365-9112 / E-mail: turkiye@autonics.com

USA **Autonics USA, Inc.**
Tel: 1-847-680-8160 / Fax: 1-847-680-8155 / E-mail: sales@autonicsusa.net

Vietnam **Cong Ty TNHH Autonics Vina**
Tel: 84-28-3771-2662 / Fax: 84-28-3771-2663 / E-mail: vietnam@autonics.com

* The dimensions or specifications on this product guide may change and some models may be discontinued without notice.

202211-Safety Brochure-EN-03