

ASCO™ MINIATURE SOLENOID VALVES

ROCKER MECHANISM, FLUID ISOLATION VALVES

- Rocker isolation valves are designed for use with neutral or highly aggressive liquids in analytical instrumentation
- Special rocker mechanism, combined with a separating diaphragm, prevents heat transfer to the fluid and eliminates the sticking effect of the valve seat
- Hermetic separation of control mechanism prevents particulate contamination caused by friction of moving parts, assuring maximum purity of liquid samples
- Excellent self-draining capability and easy-to-flush low-volume internal cavity make these valves ideal in application where cross-contamination must be minimized
- Removable and rotatable electrical coils allow for easy installation and worry-free maintenance
- Meets all relevant CE directives
- Typical applications include:
 - In-vitro Diagnostics
 - Hematology
 - DNA Sequencing
 - Surgical Fluid Management

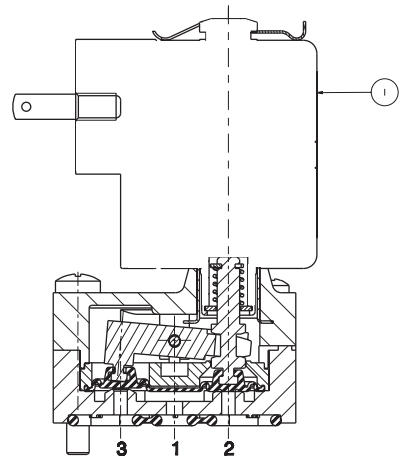
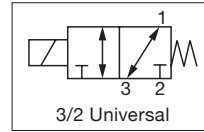

Fluids*	Temperature Range	Seal Materials*
liquids or gases	10°C to +80°C (14°F to 176°F)	FFKM (perfluoroelastomer) or EPDM (ethylene-propylene)

* Ensure that the compatibility of the materials in contact with the fluids is verified

General Valve Information		
	PEEK Body	PA Body
Body	PEEK	PA (polyamide 12)
Differential pressure	See «Specifications» [1 bar =100 kPa] 0.7 bar abs. (vacuum on polyamide body only)	
Maximum viscosity	37 cSt (mm ² /s)	
Response time	20 ms	
Internal volume	< 67 µl	

Electrical Characteristics	
Coil insulation class	F
Coil	Detachable and rotatable. Two spade terminals 2.8 x 0.5 mm (DIN 46340) (or detachable size 15 connector)
Electrical enclosure protection	Moulded IP 65 spade terminals Moulded IP 66 Solenoid lead wires (EN 60529)
Standard voltages *	12 VDC, 24 VDC

* Other voltages on request.

Prefix option	Power ratings				Ambient temperature range	Replacement coil		Type (1)
	Inrush		Holding			12 VDC	24 VDC	
	VA	VA	W	W	°C (°F)			
SC	-	-	-	4	-10 to 60 (14 to 140)	43005268	43005269	1
L	-	-	-	4	-10 to 60 (14 to 140)	43005408	43005430	2

(1) Refer to the dimensional drawings on the following page.

01003GB-2019-R01

Specifications													
Pipe Size	Orifice Size	Flow Coefficient			Operating Pressure bar (psi)			Power Rating (W)		Catalog Number		Seal Materials	
					min.	max. (PS)						FKM	EPDM
						Gases (*)	Liquids (*)						
(mm)	Kv (m ³ /h)	Cv	(l/min)	=	=	~	=	PEEK Body	PA Body				
Pad mount	1.5	0.03	0.034	0.5	0	2.4 (34.8)	2.4 (34.8)	-	4	SCS385A001		V	E
1/4" - 28 UNF thread										SCE385A001			
Barbed fitting										SCH385A001			
Pad mount	1.5	0.03	0.034	0.5	0	2 (29.0)	2 (29.0)	-	4		SCS385A002E	-	-
1/4" - 28 UNF thread											SCE385A002E		
Barbed fitting											SCH385A002E		

How To Order

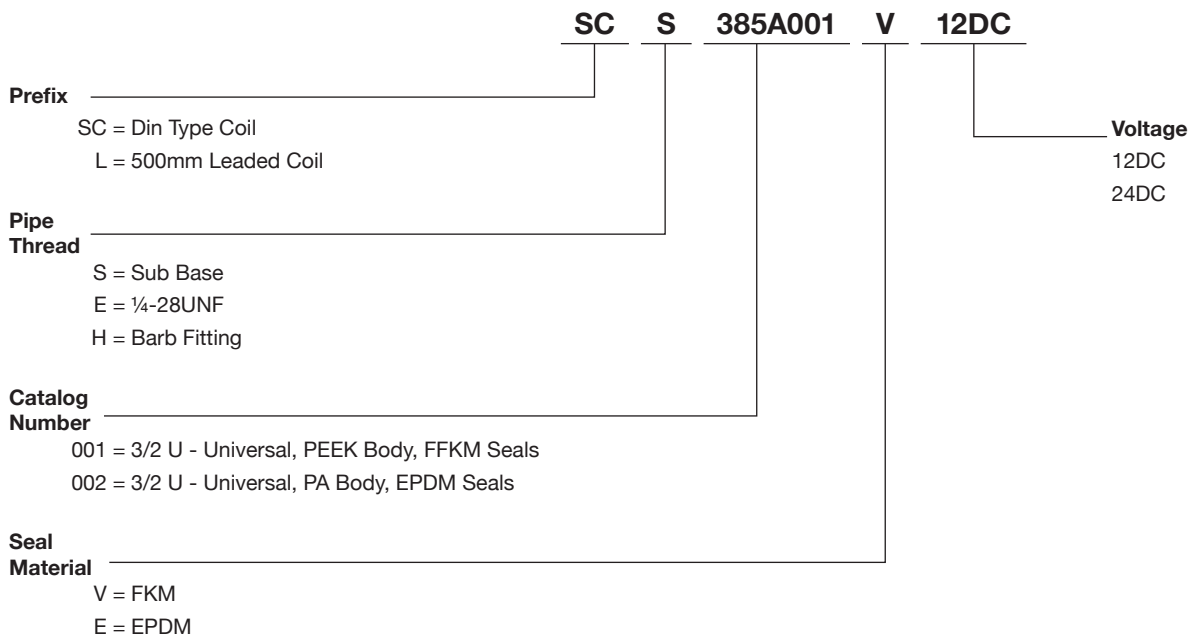

Options

- Connector size 15, catalogue number 88143581

Installation

- The solenoid valves can be mounted in any position without affecting operation.
- Can be used for the following functions, depending on how the ports are connected:
- Installation/maintenance instructions are included with each valve.

ASCO™ MINIATURE SOLENOID VALVES

ROCKER MECHANISM, FLUID ISOLATION VALVES

Dimensions: mm (inches)



Type 01
Solenoid with spade terminals (SC)
EN 60529
IP 65

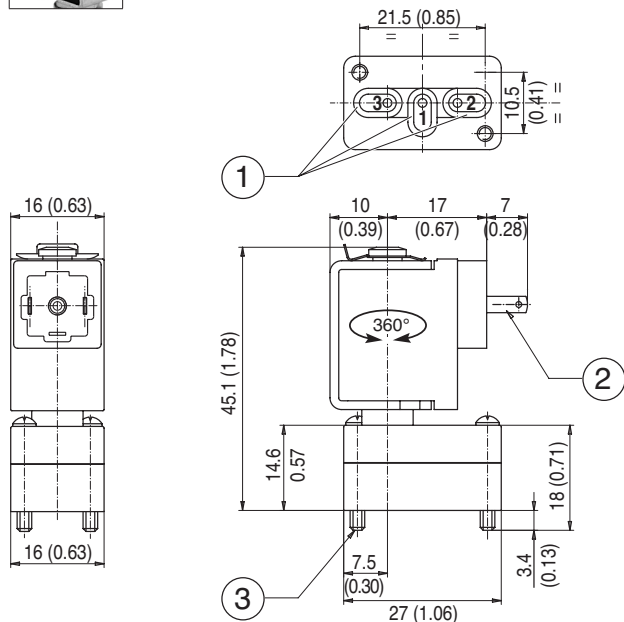

- ① 1 mounting pad seal.
- ② Coil with 2 Faston-type terminals 2.8 x 0.5 (DIN 46340).
- ③ Mounting : 2 screws M2.5 x 18.

Type	Prefix option	Weight (1) kg
01	SC	0.04

(1) Including coil, without connector.



Type 02
Leaded Coil (L)
24 AWG, lead wires: 500 mm (19.7 in) long
IP 66

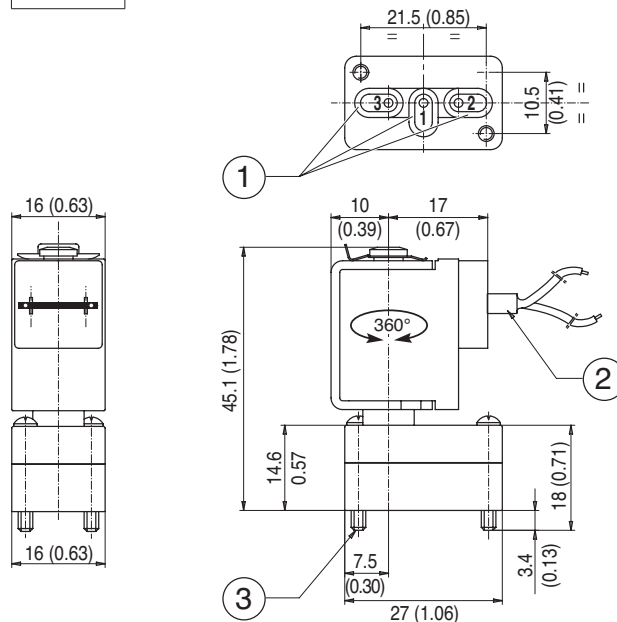

- ① 1 mounting pad seal.
- ② Coil with 24 AWG, lead wires: 500mm (19.7in) long
- ③ Mounting : 2 screws M2.5 x 18.

Type	Prefix option	Weight (1) kg
02	L	0.04

(1) Including coil, without connector.

Dimensions: mm (inches)

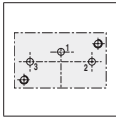

Pad Mount

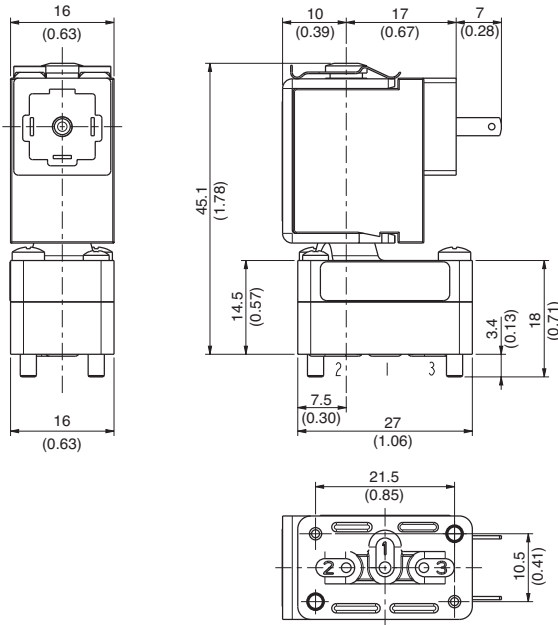

1/4" - 28 UNF thread

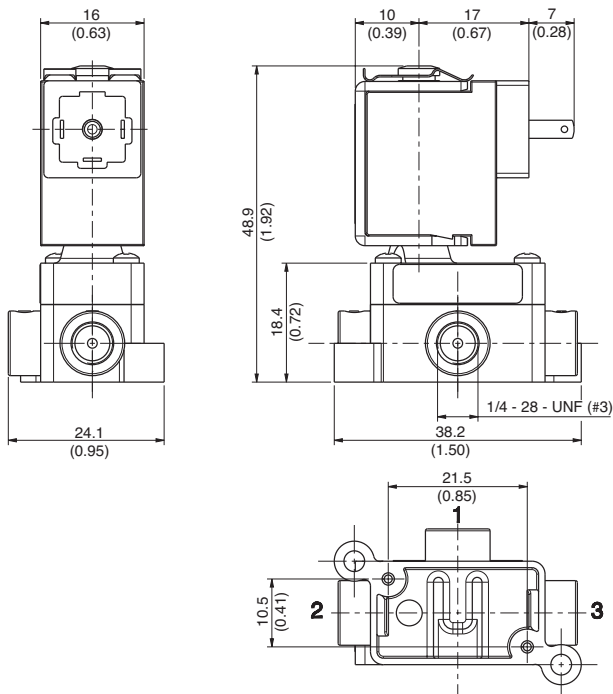

Barbed Fitting

