

# Pressure-Core® Seal

Advanced Stem Seal System



## A Superior Design for Better Performance

Parker's patented Pressure-Core® Stem Seal System was tested by an independent laboratory in accordance with EPA Method 21, and the results indicate that the Pressure-Core® Stem Seal is a reliable, affordable, virtually leak-free bonnet requiring no costly, time consuming maintenance.

After years of field experience and millions of valves in service, Parker takes great pride in extending a five-year limited warranty on our Pressure-Core® Stem Seal, far exceeding the industry standard.

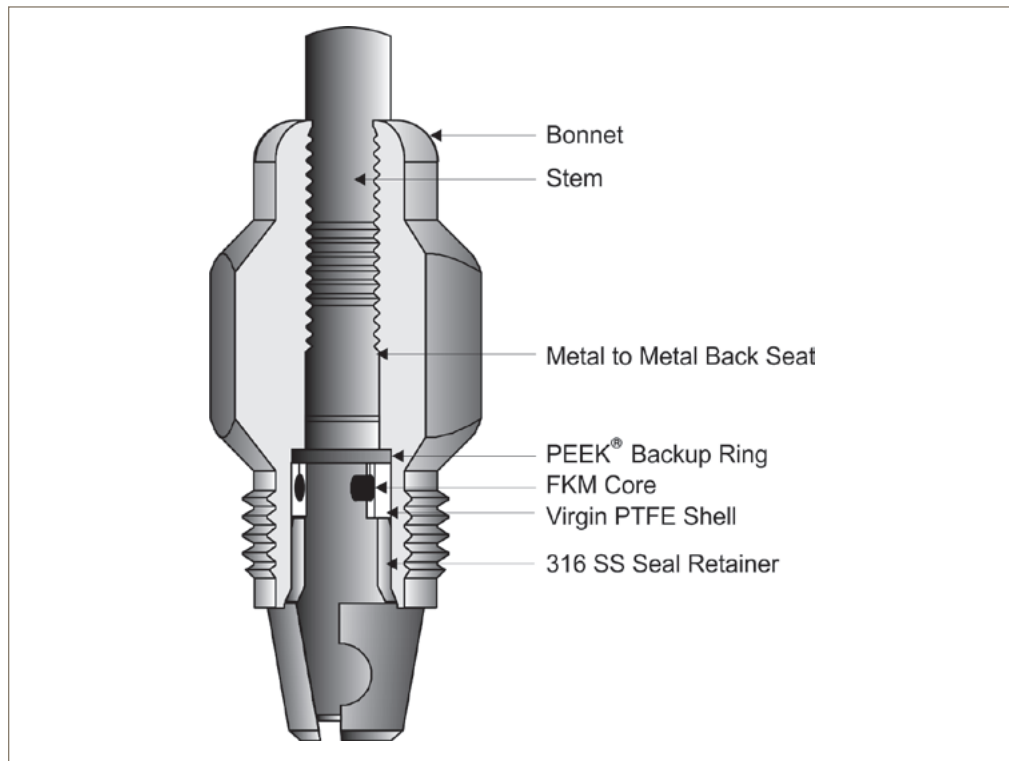

## Contact Information:

Parker Hannifin Corporation  
**PGI Division**  
16101 Vallen Drive  
Houston, TX 77041 USA

phone 713 466 0056  
fax 800 568 9228  
pgi\_sales@parker.com

[www.parker.com/pgi](http://www.parker.com/pgi)  
[www.pgiint.com](http://www.pgiint.com)

## Product Features:

- Virtually Leak-Free Performance
- No Adjustments or Maintenance Requirements
- Unmatched 5 Year Warranty
- No Fugitive Emissions



ENGINEERING YOUR SUCCESS.

# Pressure-Core® Seal

## How We Do It!

The Pressure-Core® Seal consists of an outer PTFE shell with an elliptical shaped FKM O-Ring core. The encapsulated core is “live- loaded” and provides constant outward pressure against the PTFE shell, which flexes under pressure like an O-Ring. The PTFE shell offers the desired chemical resistance without periodic gland tightening as in conventional designs.

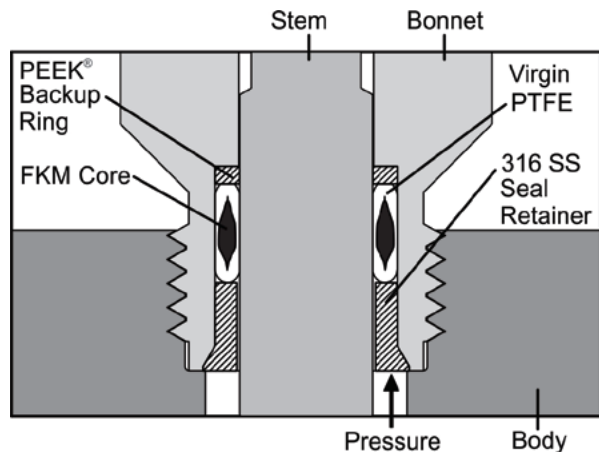

## Testing Proves It!

Compared to competitive bonnet designs, Parker’s Pressure-Core® Seal offers virtually leak-free performance with no maintenance requirements. To support this claim, the Pressure-Core® Seal was tested against the competitors’ design. The tests simulated harsh plant operating environments and were performed by an independent laboratory in accordance with EPA Method 21.

Test results indicate that the Pressure-Core® Seal is a reliable, affordable, virtually leak-free bonnet requiring no costly, time consuming maintenance. Parker stands behind this claim with a five year warranty, far exceeding the industry standard.

## Fugitive Emissions Test Results

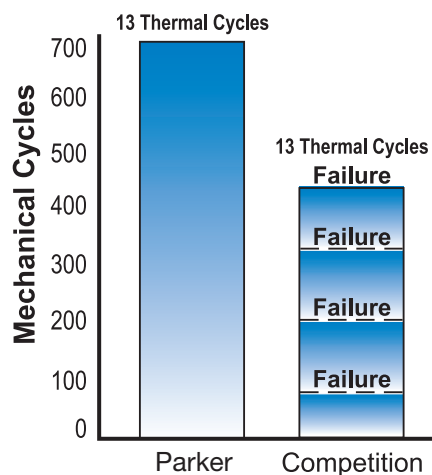

*See for yourself how our Pressure-Core® not only outperforms the competition, but sets a new industry standard...*

### Test Procedure

Valves mechanically cycled 50 times (full open to full close) at 1,000 PSI methane, then heated to 400°F and air cooled to ambient. Procedure repeated until failure.

### Failure Criteria

100 PPM leak\*

\*Competition’s Emission Seal Warranty

### TEST RESULTS

**Parker:** The Pressure-Core Seal successfully completed 694 mechanical cycles and 13 thermal cycles. Maximum leakage throughout testing was 40 PPM.

**Competition:** The competition’s “low emissions” graphite design failed on the 89th mechanical cycle and on average every 125 cycles throughout the testing. Repeated maintenance was required between each failure to readjust the valve packing.

Safety Guide – See [www.parker.com/safety](http://www.parker.com/safety).

© 2015 Parker Hannifin Corporation. All rights reserved.

Bulletin PGI-PCS 01/2015-DDP



Your Local Authorized Parker Distributor