

**FLAT TOP BALL VALVE ELIMINATES DAMAGE  
FROM CRUSTY MATERIALS**

Milled Flat Top Ball  
Purge Port  
(rotated 90 ° from actual for clarity)

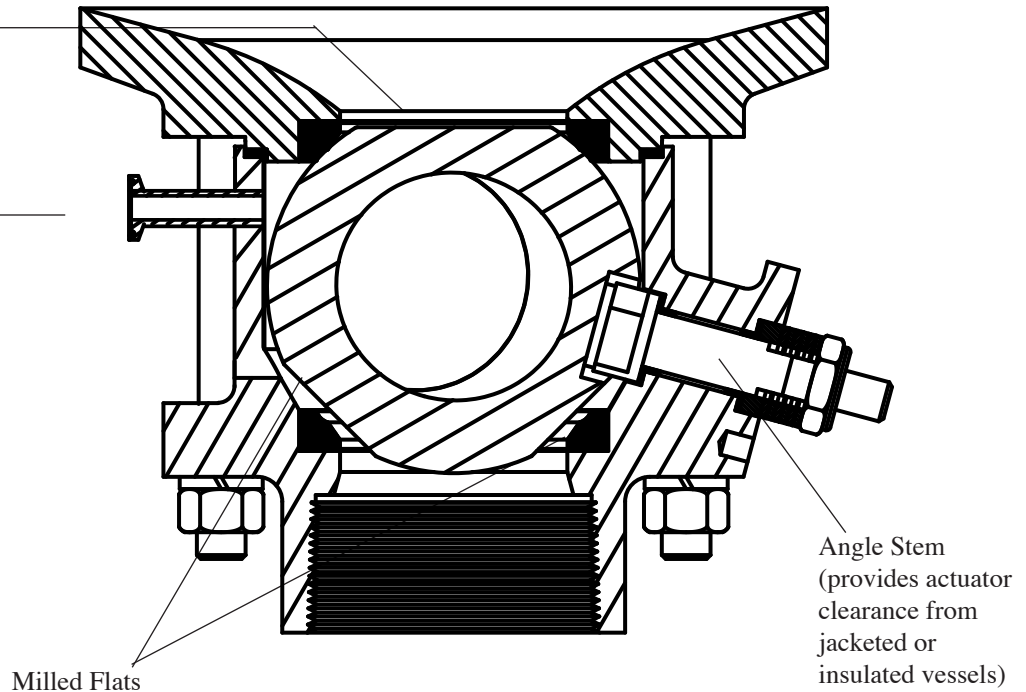

This illustration shows how a single Purge Port and two Milled Flats on the bottom of the ball would work together to flush and drain trapped materials. The valve could also be designed with one inlet and one outlet Purge Port, without Milled Flats, to facilitate the cleaning

**Problem**

Adhesives, paints, resins, and other viscous materials have a sticky, gummy quality when heated, but become crusty when cool.

When these materials settle on top of a round-faced ball in a standard flush tank ball valve, they form a rounded crust. When the valve is opened, the round-faced ball pushes the crust against the valve seats.

After repeated openings and closings, the hardened crust scores the ball, and the crust-like particles become embedded in the seats. These conditions will cause the valve to leak.

The leaking valve then needs to be serviced, wasting considerable production time and money.

**Solution**

PBM solved this problem by developing a Flush Tank valve with a milled flat on the top of the ball.

As material from the tank settles, a flat crust is formed on the milled flat top surface of the ball. Then, when the valve is opened, the flat surface moves away from the seats without pushing the crust into the seats. As the crust breaks apart, the flat top creates a space for the crust to be cleaned away easily. Additional features such as Purge Ports and Milled Flats can be added to help flush and drain the body cavity of any trapped media that could seize or score the ball.

**Benefits**

- ◆ Milled Flat Top Flush Tank Valve eliminates leakage caused by ball scoring and seat damage from hardened adhesives, paints, and resins.
- ◆ Improved performance reduces downtime and maintenance costs.

Another creative solution by PBM . . .

## FLAT TOP BALL VALVE ELIMINATES DAMAGE FROM CRUSTY MATERIALS

---

---

Would you like more information about this Creative Solution?

Yes                       No

If yes, please fill out the spaces below:

Name: \_\_\_\_\_

Company: \_\_\_\_\_

Telephone: \_\_\_\_\_

Fax: \_\_\_\_\_

Fax, mail, telephone, or e-mail this request to:

Name:                      Jay Giffen

Fax:                              724.864.9255

Mail:                          PBM, Inc.  
                                    1070 Sandy Hill Road  
                                    Irwin, PA 15642

Telephone:                800.967.4PBM

E-Mail:                      info@pbmvalve.com

Would you like information about any other PBM valves?

- |   |   |
|---|---|
| <input type="radio"/> 2-Way Ball Valves                 | <input type="radio"/> Diverter Port Ball Valves     |
| <input type="radio"/> 2-Way ANSI Ball Valves            | <input type="radio"/> Multi-Port Ball Valves        |
| <input type="radio"/> Flush Tank Ball Valves            | <input type="radio"/> Cavity Free Rotor Valves      |
| <input type="radio"/> Angle Stem Flush Tank Ball Valves | <input type="radio"/> Fabflex® Sanitary Ball Valves |
| <input type="radio"/> Igenix™ Sanitary Ball Valves      | <input type="radio"/> Other                         |