

SERIES GU CONTROL VALVES GLOBE-SINGLE SEATED, TOP GUIDED

Metso's Neles series GU single seated, top guided globe valves are economical high-performance control valves designed to provide the best possible control accuracy and wide rangeability with all the inherent benefits of linear control valves. Standard units are equipped with spring diaphragm actuators and NDX® intelligent valve controllers for precise flow control, extended operational life and performance monitoring on-line.

Construction

- Compact and lightweight construction
- Wide variety of trims with different Cv and characteristics
- Both metal and soft seats are available depending on the application
- Optional bellows seal for toxic or other applications where no stem seal leakage is allowed
- Wide material selection for different applications
- Many end connection styles available for different applications
- Extension bonnet design for wide temperature range

Accurate control

- NDX digital valve controller for auto-calibration and accurate control
- Accurate and sensitive diaphragm and piston actuators

Wide range of applications

- Suitable for gas, liquid and steam
- Temperature limits -29 ... +260 °C (-20 ... +500 °F) with general bonnet construction. Over +260 °C (+500 °F) and under -29 °C (-20 °F) with extended bonnets.
- Tendril multi-hole trim for high pressure drop and cavitation applications
- Micro trim for small flow and/or to get rid of the stability problems in high pressure drop application
- Inherently characterized trims offered in equal percentage, linear and quick open



Safety and quality

- Rugged one piece body to minimize the leak paths and makes the valve less prone to pipe stress
- Strictly tested to ensure specified performance with quality assurance systems in accordance to ISO 9001
- Certified ISO 15848 fugitive emissions
- Certified CE/PED & ATEX, TSG & EAC (GOST-R)

Easy maintenance

- Quick change trim and top entry construction for easy in-line maintenance
- Self guided components makes for easy valve assembly
- Flow characteristics can be easily changed with interchangeable trim components
- NDX digital valve controller with online diagnostics enables performance follow up and predictive maintenance
- Efficient asset management with Metso FieldCare open architecture software and excellent networking capabilities

Different trim designs

Contoured trim

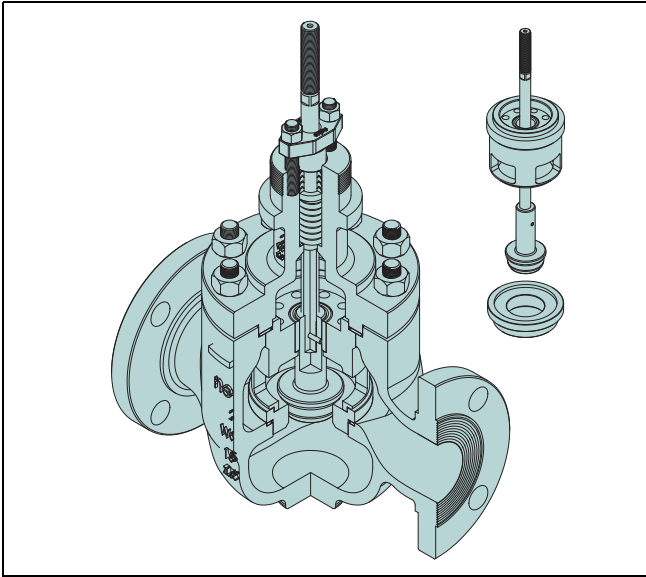

Quick change, general contoured trim

Quick change, general contoured plug offers a smooth flow profile. The trim is most suited to low pressure drop application and is used in the majority of control applications.

Tendril (multi-hole) trim

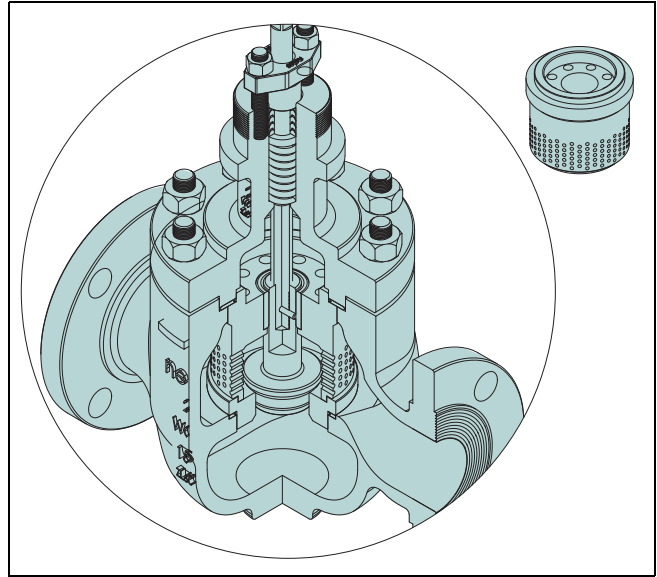

Tendril trim

The trim design presented a multi-hole trim. There is Tendril 1 design in standard depending on pressure drop and potential for cavitation. The pressure drop is divided by multi-holes so that the pressure progressively reduces as it passes through the trim. This gives excellent resistance to cavitation on high pressure drop applications.

Contoured soft seat trim

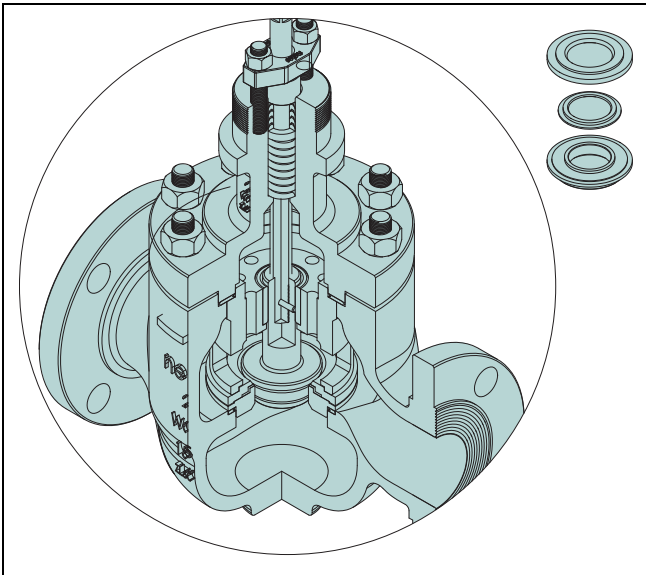

Soft seat trim

An alteration of the standard contoured trim is the soft seated option. The seat ring is manufactured with a clamped on shroud which locks the soft seated ring in position. When the soft face contacts the seating point it deforms the softer ring ensuring a high degree of closure. The soft seated trim is used on applications where bubble tight shut off is required.

Micro trim

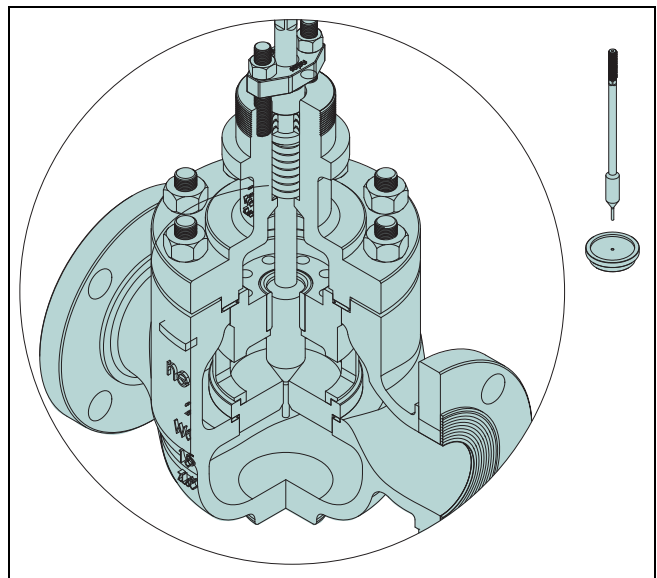

Micro trim

The micro trim design is seat guided construction, capable of handling high pressure drops, without instability problems. This trim design has an inherent characteristic of linear, and has excellent rangeability. It is an ideal selection for the control of very low flow rates. Please contact Metso for micro trim applications.

Components & materials

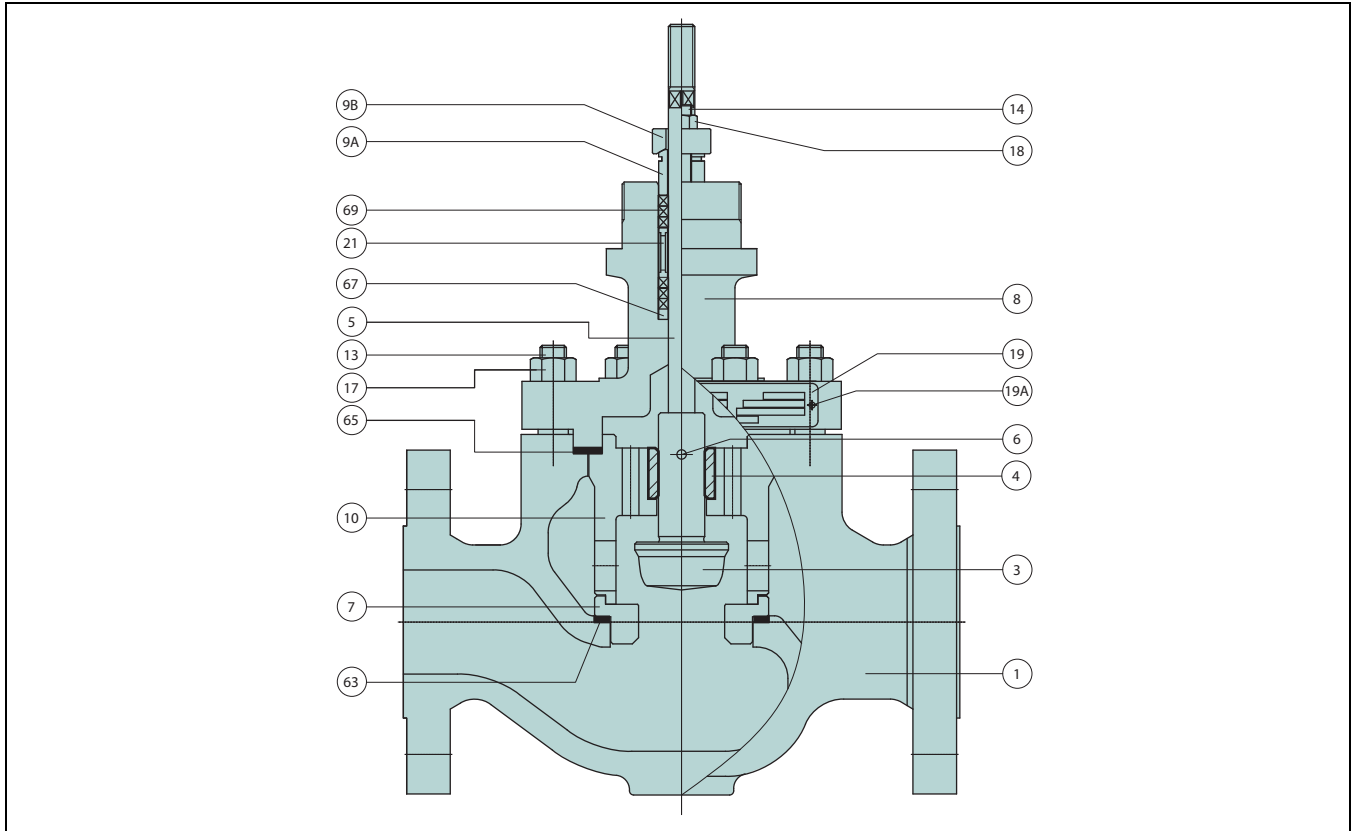

Body material: Carbon steel or alloy steel

Part no.	Description	Material
1	BODY	A216 WCB / ALLOY STEEL AVAILABLE
2	PLUG SET	410 SS / 630 SS
3*	PLUG	410 STAINLESS STEEL
4	GUIDE BUSHING	440C STAINLESS STEEL
5*	STEM	630 STAINLESS STEEL + HCr
6*	PLUG PIN	316 STAINLESS STEEL
7	SEAT RING	410 STAINLESS STEEL
8	BONNET	A216 WCB / ALLOY STAINLESS STEEL
9A	GLAND	304 STAINLESS STEEL
9B	GLAND FLANGE	A351 CF8
10	RETAINER	630 STAINLESS STEEL
13	STUD	A193 Gr.B7
14	STUD	A193 Gr.B8
17	HEXAGON NUT	A194 Gr.2H
18	HEXAGON NUT	A194 Gr.8
19	IDENTIFICATION PLATE	304 STAINLESS STEEL
19A	RIVET	304 STAINLESS STEEL
21	LANTERN RING	304 STAINLESS STEEL
63	SEAT GASKET	S/W GASKET, 316L SS + GRAPHITE
65	BODY GASKET	S/W GASKET, 316L SS + GRAPHITE
67	PACKING SPACER	304 STAINLESS STEEL
69	PACKING RING	PTFE + CARBON FIBER

Note.

1. Plug/Seat Hard Facing(Cobalt based alloy) & Soft Seat are available.
2. Materials description
316 SS : ASTM A276 TP316 or JIS 316 St. Steel
440C SS : ASTM A276 TP440C or JIS 440C St. Steel
410 SS : ASTM A276 TP410 or JIS 410 St. Steel
3. Above standard materials to be applicable depending on specific service conditions, other optional materials to consult Metso
4. Optional materials to meet to requirements of NACE MR 01-75 are available
5. The materials are subject to change as equivalent depending on detail design
6. The part no.3*, 5*, *6 are delivered as a set with no.2
7. The body name plate is attached to the body when only the bare shaft is required and attached to the actuator when whole assembly (It means to assemble valve and actuator) is required.

Body material: Stainless steel

Material	Spare
A351 CF8M	
316 SS / 316 SS	Cat 3
316 STAINLESS STEEL	Cat 3
316 + COBALT BASED ALLOY	
316 STAINLESS STEEL + HCr	Cat 3
316 STAINLESS STEEL	Cat 3
316 STAINLESS STEEL	Cat 3
A351 CF8M	
304 STAINLESS STEEL	
A351 CF8	
A351 CF8M	Cat 3
A193 Gr.B8(M)	
A193 Gr.B8	
A194 Gr.8(M)	
A194 Gr.8	
304 STAINLESS STEEL	
304 STAINLESS STEEL	
304 STAINLESS STEEL	
S/W GASKET, 316L SS + GRAPHITE	Cat 1
S/W GASKET, 316L SS + GRAPHITE	Cat 1
304 STAINLESS STEEL	
PTFE + CARBON FIBER	Cat 1

Note.

1. Plug/Seat Hard Facing(Cobalt based alloy) & Soft Seat are available
2. Materials description
316 SS : ASTM A276 TP316 or JIS 316 St. Steel
3. Above standard materials to be applicable depending on specific service conditions, other optional materials to consult Metso
4. Cryogenic application : ASTM A320 B8M & 8M for Studs(13) and Nuts(17)
5. Optional materials to meet to requirements of NACE MR 01-75 are available
6. The materials are subject to change as equivalent depending on detail design
7. The part no.3*, 5*, *6 are delivered as a set with no.2
8. The body name plate is attached to the body when only the bare shaft is required and attached to the actuator when whole assembly (It means to assemble valve and actuator) is required.

GU, Application guide

GU, Temperature range and seat leakage class with different bonnet and seat application

Valve Size DN / Inch	ASME rating	Seat type	Temperature range (°C)		Seat leakage class (ANSI B 16.104)	
			General bonnet	Extension bonnet	Standard	Optional
15/0.5~ 100/4	150 ~ 600	Metal Seat	-29 ~ +260	-109 ~ +593	IV	V
		Soft Seat	-29 ~ +232	-109 ~ +232	VI	
15/0.5~ 80/3	900 ~ 2500	Metal Seat	-29 ~ +260	-109 ~ +593	IV	V

Temperature range with different body and stud/nut materials

Body, Bonnet Material	Stud Bolt , Nut material	Temp. range, (°C)	Sign
Carbon steel (WCB, A105)	ASTM A193-B7 STUD ASTM A194-2H NUT	-29 ~ +425	A
Stainless steel (CF3, CF8,CF3M, CF8M)	ASTM A193-B7 STUD ASTM A194-2H NUT	-46 ~ +538	A
	ASTM A193(320)-B8(M) STUD ASTM A194(320)-8(M) NUT	-196 ~ +538	B
Cr.Mo. Steel (WC6, F11, WC9, F22,C12A, F91)	ASTM A193-B16 STUD ASTM A194-4 NUT	-29 ~ +593	*

*Please contact Metso

Trim materials

GU, Trim				Temperature range (°C)	Sign
Plug	Stem	Seat	Retainer		
410 SS	630 SS + HCr	410 SS	630 SS	-29 ~ +425	P1XBCS1R1X
316 SS	316 SS + HCr	316 SS	316 SS	-196 ~ +315	T6XTCS1T6X
316 SS + Cobalt based alloy	316 SS + HCr	316 SS + Cobalt based alloy	316 SS	-196 ~ +425	T6ATCS1T6A
420 J2	630 SS + HCr	420 J2	420 J2	-10 ~ +540	*
316 SS	316 SS + HCr	316 SS + PTFE	316 SS	-196 ~ +232	*
630 SS	630 SS + HCr	410 SS	410 SS	-29 ~ +425	*
Inconel 718	Inconel 718	F91	F91	-29 ~ +593	*
Inconel 625, 718, 750				-196 ~ +645	*

*Please contact Metso

Gasket applications

Body, Bonnet material	Gasket material	Temp. range (°C)	Sign
Carbon steel WCB, A105	S/W (Spiral Wound) 316SS + Graphite	-29 ~ +425	S
Stainless steel CF8, CF8M, CF3, CF3M	S/W (Spiral Wound) 316L SS + Graphite	-196 ~ +425	S
	S/W (Spiral Wound) 316SS + PTFE	-196 ~ +232	L
Cr.Mo. Steel WC6, WC9, F22, C12A, F91	S/W (Spiral Wound) 316L SS + Graphite (Aramid)	-29 ~ +593	H
	S/W (Spiral Wound) 316L SS+ Graphite + Mica (special Hi-Temp. max 950)		*

*Please contact Metso

Packing applications

Packing material	Temp (°C)	Pr. Class	Sign
PTFE + Carbon Fiber (Braided TEF + Graphite), standard	-196 ~ +260	Up to CL900	G
PTFE V-Ring	- 49 ~ +232	Up to CL600	T
Graphite (with Mold + Braided)	-196 ~ +400	Up to CL2500	F
Hi-Graphite (with Mold + Braided)	-49 ~ +593	Up to CL2500	H
RTFEV-Ring + Metal	- 40 ~ +350	Up to CL600	M

Flow direction

Fluid Media	Flow to Open	Flow to Close
Liquid	o	*
Steam Gas	o	*

*Please contact Metso

Cv Ratio 50: 1

Flow Characteristics Equal percentage, linear and quick open

GU, Ratings & end connetions

Valve size DN / Inch"	GU, ASME Ratings							
	Class 150 - 600				Class 900 - 2500			
	RF	RTJ	SW	BW	RF	RTJ	SW	BW
25 / 1	O	O	O		O	O	O	
40 / 1-1/2	O	O	O		O	O	O	
50 / 2	O	O	O		O	O	O	O
80 / 3	O	O		O				
100 / 4	O	O		O				

*Note 1. RF: Raised Face Flange, RTJ: Ring Joint, SW: Socket Weld, BW: Butt Weld

Packing constructions

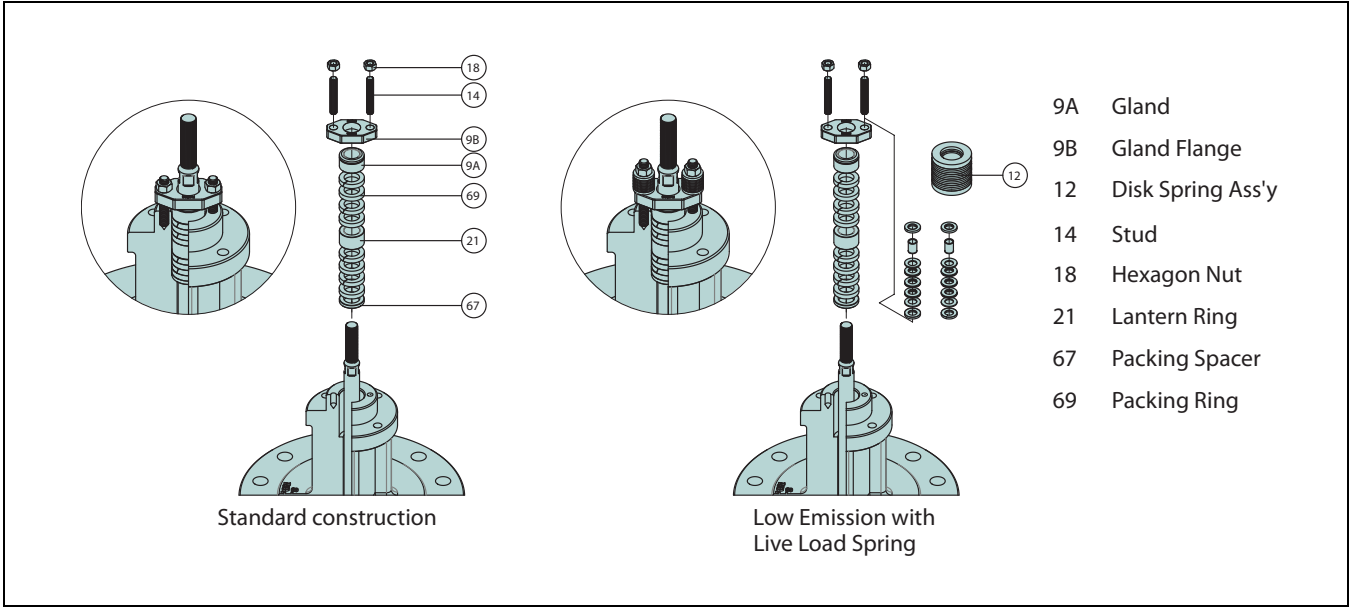

Rated Cv and trim table(Globe single seat, unbalanced type, series GU)

20. Sign	TRIM TYPE	21. Sign	TRIM CHARACTERISTIC	22. Sign	RATED Cv																
					Description	Body size and stroke															
						0.5" Str.	0.75" Str.	1" Str.	1.5" Str.	2" Str.	3" Str.	4" Str.	6" Str.								
A	General plug	L	Linear	FC	General / Full capacity	7 (20)	9 (20)	13.5 (20)	28 (20)	49 (20)	100 (40)	190 (40)	295 (60)								
				E	Equal %	1A	General / 1-Step reduction	4 (20)	5.5 (20)	8.5 (20)	16 (20)	28 (20)	70 (40)	120 (40)	165 (60)						
				2A	General / 2-Step reduction	2.3 (20)	3 (20)	5.4 (20)	10.5 (20)	17 (20)	42 (40)	72 (40)	85 (60)								
				3A	General / 3-Step reduction	1.5 (20)	2 (20)	3.1 (20)	6 (20)	10 (20)	25 (40)	42 (40)	50 (60)								
				4A	General / 4-Step reduction	0.8 (20)	1.2 (20)	2 (20)	4 (20)												
				5A	General / 5-Step reduction	0.5 (20)	0.7 (20)	1.2 (20)	2.2 (20)												
				6A	General / 6-Step reduction	0.3 (20)	0.4 (20)	0.8 (20)	1.2 (20)												
				FT	Tendril / Full capacity	7 (20)	9 (20)	13.5 (20)	28 (20)	49 (20)	100 (40)	190 (40)	295 (60)								
				1T	Tendril / 1-Step reduction	4 (20)	5.5 (20)	8.5 (20)	16 (20)	28 (20)	70 (40)	120 (40)	165 (60)								
				2T	Tendril / 2-Step reduction	2.3 (20)	3 (20)	5.4 (20)	10.5 (20)	17 (20)	42 (40)	72 (40)	85 (60)								
				3T	Tendril / 3-Step reduction	1.5 (20)	2 (20)	3.1 (20)	6 (20)	10 (20)	25 (40)	42 (40)	50 (60)								
				4T	Tendril / 4-Step reduction	0.8 (20)	1.2 (20)	2 (20)	4 (20)												
				5T	Tendril / 5-Step reduction	0.5 (20)	0.7 (20)	1.2 (20)	2.2 (20)												
				6T	Tendril / 6-Step reduction	0.3 (20)	0.4 (20)	0.8 (20)	1.2 (20)												
C	Micro plug	L	Linear	FC	General / Full capacity	0.1 (20)	0.1 (20)	0.1 (20)													
				1A	General / 1-Step reduction	0.06 (20)	0.06 (20)	0.06 (20)													
				2A	General / 2-Step reduction	0.03 (20)	0.03 (20)	0.03 (20)													
				3A	General / 3-Step reduction	0.01 (20)	0.01 (20)	0.01 (20)													
				4A	General / 4-Step reduction	0.006 (20)	0.006 (20)	0.006 (20)													
				5A	General / 5-Step reduction	0.003 (20)	0.003 (20)	0.003 (20)													
Y	Special	Y	Special	YY	Special	Contact Metso for Cv details															

- Rated Cv is different depending on trim type and characteristic.
 - Str. : valve stroke length(mm). It should be matched with actuator stroke length.

GU Series Cv vs Travel (General Contoured)

ANSI Class: 150# ~ 1500#

Size: 1/2" ~ 6"

Flow Characteristic: LINEAR

Valve Travel [%]							10	20	30	40	50	60	70	80	90	100	
F _L							0.93	0.93	0.92	0.92	0.91	0.91	0.91	0.90	0.90	0.90	0.90
Valve Size		Orifice Dia.			Travel		Rated Cv										
Inch	mm	Sign	Inch	mm	Inch	mm											
1/2"	15	FC	0.6	15.7	0.8	20	0.53	1.27	1.95	2.66	3.38	4.09	4.76	5.51	6.67	7.0	
		1A	0.4	11.0			0.36	0.74	1.23	1.61	1.99	2.37	2.72	3.05	3.41	4.0	
		2A	0.3	8.0			0.28	0.53	0.79	1.07	1.32	1.52	1.71	1.88	2.03	2.3	
		3A	0.3	6.4			0.19	0.36	0.52	0.67	0.82	0.97	1.15	1.28	1.38	1.5	
		4A	0.3	6.4			0.09	0.17	0.25	0.32	0.40	0.47	0.54	0.61	0.68	0.8	
		5A	0.3	6.4			0.06	0.11	0.15	0.20	0.25	0.30	0.35	0.40	0.45	0.5	
		6A	0.3	6.4			0.04	0.07	0.10	0.12	0.15	0.18	0.21	0.24	0.27	0.3	
3/4"	20	FC	0.7	17.2	0.8	20	0.85	1.68	2.57	3.31	4.04	4.74	5.43	6.18	7.61	9.0	
		1A	0.5	13.0			0.35	0.82	1.40	2.17	2.78	3.39	3.98	4.53	5.03	5.5	
		2A	0.4	9.0			0.29	0.74	1.08	1.40	1.73	2.13	2.37	2.60	2.80	3.0	
		3A	0.3	7.2			0.24	0.44	0.63	0.81	0.99	1.16	1.32	1.47	1.62	2.0	
		4A	0.3	6.4			0.13	0.24	0.36	0.48	0.60	0.72	0.84	0.96	1.08	1.2	
		5A	0.3	6.4			0.08	0.15	0.22	0.28	0.35	0.42	0.49	0.56	0.63	0.7	
		6A	0.3	6.4			0.05	0.09	0.13	0.17	0.21	0.25	0.28	0.32	0.36	0.4	
1"	25	FC	0.9	22.3	0.8	20	1.29	2.62	4.02	5.42	6.83	8.13	8.90	10.25	11.93	13.5	
		1A	0.6	15.0			0.77	1.54	2.31	3.15	3.92	4.68	5.42	6.12	7.00	8.5	
		2A	0.5	11.5			0.46	0.94	1.43	1.94	2.46	3.02	3.52	4.00	4.44	5.4	
		3A	0.4	9.0			0.28	0.56	0.86	1.16	1.47	1.77	2.07	2.36	2.66	3.1	
		4A	0.3	7.2			0.18	0.37	0.57	0.78	0.99	1.20	1.41	1.61	1.79	2.0	
		5A	0.3	6.4			0.11	0.23	0.35	0.47	0.59	0.71	0.83	0.95	1.07	1.2	
		6A	0.3	6.4			0.07	0.14	0.21	0.28	0.34	0.41	0.48	0.55	0.62	0.8	
1-1/2"	40	FC	1.2	30.0	0.8	20	2.64	5.38	8.46	11.77	15.22	18.77	21.56	24.09	26.50	28.0	
		1A	0.8	21.5			1.63	3.16	4.70	6.25	7.90	9.52	11.12	12.68	14.18	16.0	
		2A	0.6	16.0			0.95	1.89	2.86	3.86	4.88	5.88	6.90	7.92	8.86	10.5	
		3A	0.5	12.5			0.57	1.13	1.72	2.33	2.96	3.58	4.19	4.78	5.33	6.0	
		4A	0.4	10.0			0.37	0.74	1.14	1.54	1.96	2.38	2.79	3.18	3.55	4.0	
		5A	0.3	7.0			0.19	0.38	0.57	0.78	0.99	1.19	1.40	1.60	1.78	2.2	
		6A	0.3	6.4			0.12	0.24	0.36	0.47	0.59	0.71	0.83	0.95	1.06	1.2	
2"	50	FC	1.7	43.9	0.8	20	4.13	9.24	14.48	19.71	25.09	30.56	35.97	40.01	44.64	49.0	
		1A	1.3	33.4			2.27	4.97	7.88	10.94	13.72	16.51	19.28	22.03	24.97	28.0	
		2A	0.8	21.5			1.26	2.76	4.37	6.05	7.77	9.53	11.23	12.73	14.32	17.0	
		3A	0.6	16.0			0.82	1.78	2.80	3.86	4.93	5.98	7.01	7.98	8.89	10.0	
3"	80	FC	2.8	72.0	1.5	40	9.96	21.06	32.40	42.65	52.98	63.70	76.67	86.07	91.15	100.0	
		1A	1.9	47.0			5.35	11.64	18.74	26.58	33.66	40.46	47.18	53.74	60.34	70.0	
		2A	1.3	34.0			3.47	7.21	11.20	15.38	19.69	24.06	28.45	31.99	35.66	42.0	
		3A	1.0	25.0			2.17	4.47	6.86	9.32	11.81	14.29	16.73	19.08	21.29	25.0	
4"	100	FC	3.6	91.5	1.5	40	12.67	27.12	47.27	66.04	85.99	106.88	127.85	147.47	167.93	190.0	
		1A	2.4	60.0			7.32	15.77	25.33	36.43	51.05	63.30	75.78	88.32	103.94	120.0	
		2A	1.7	43.0			7.02	13.84	20.64	27.41	34.07	43.44	50.85	57.09	63.09	72.0	
		3A	1.3	32.0			4.03	8.16	12.45	16.82	21.18	25.44	29.51	33.31	37.67	42.0	
6"	150	FC	4.5	115.0	2.4	60	28.43	57.15	86.05	112.26	136.07	159.16	181.59	212.57	263.12	295.0	
		1A	3.0	75.0			16.09	32.01	47.67	63.09	78.18	93.11	105.76	117.42	137.91	165.0	
		2A	1.8	46.5			8.78	17.43	25.90	34.15	42.13	49.78	57.07	63.94	71.49	85.0	
		3A	1.4	35.5			4.32	9.07	14.14	19.45	24.88	30.32	35.64	40.72	45.42	50.0	

ANSI Class: 150# ~ 1500#

Size: 1/2" ~ 6"

Flow Characteristic: EQ%

Valve Travel [%]							10	20	30	40	50	60	70	80	90	100	
F _L							0.93	0.93	0.93	0.93	0.93	0.92	0.92	0.91	0.91	0.91	0.90
Valve Size		Orifice Dia.			Travel		Rated Cv										
Inch	mm	Sign	Inch	mm	Inch	mm											
1/2"	15	FC	0.6	15.7	0.8	20	0.16	0.36	0.56	0.89	1.38	2.16	3.42	4.84	6.44	7.0	
		1A	0.4	11.0			0.06	0.16	0.31	0.49	0.78	1.46	2.17	2.88	3.53	4.0	
		2A	0.3	8.0			0.08	0.16	0.23	0.34	0.59	0.94	1.37	1.70	2.01	2.3	
		3A	0.3	6.4			0.05	0.09	0.14	0.20	0.35	0.56	0.82	1.11	1.33	1.5	
		4A	0.3	6.4			0.02	0.04	0.06	0.08	0.16	0.28	0.41	0.54	0.66	0.8	
		5A	0.3	6.4			0.01	0.02	0.04	0.05	0.10	0.17	0.25	0.33	0.41	0.5	
		6A	0.3	6.4			0.01	0.01	0.02	0.03	0.06	0.11	0.15	0.20	0.25	0.3	
3/4"	20	FC	0.7	17.2	0.8	20	0.24	0.45	0.67	1.07	1.85	2.93	4.02	5.23	7.13	9.0	
		1A	0.5	13.0			0.06	0.20	0.40	0.67	1.11	1.79	2.79	3.71	4.74	5.5	
		2A	0.4	9.0			0.05	0.17	0.28	0.45	0.78	1.20	1.80	2.35	2.72	3.0	
		3A	0.3	7.2			0.04	0.09	0.15	0.21	0.41	0.68	1.00	1.30	1.67	2.0	
		4A	0.3	6.4			0.03	0.06	0.09	0.13	0.25	0.42	0.62	0.82	1.01	1.2	
		5A	0.3	6.4			0.01	0.03	0.05	0.08	0.14	0.23	0.34	0.45	0.58	0.7	
		6A	0.3	6.4			0.01	0.02	0.03	0.04	0.08	0.14	0.21	0.27	0.33	0.4	
1"	25	FC	0.9	22.3	0.8	20	0.27	0.57	0.91	1.55	2.75	4.66	7.08	9.49	11.63	13.5	
		1A	0.6	15.0			0.12	0.29	0.51	0.83	1.56	2.70	4.14	5.61	7.03	8.5	
		2A	0.5	11.5			0.07	0.19	0.33	0.53	0.97	1.67	2.65	3.59	4.37	5.4	
		3A	0.4	9.0			0.03	0.09	0.19	0.32	0.58	1.00	1.52	2.05	2.54	3.1	
		4A	0.3	7.2			0.03	0.08	0.13	0.22	0.40	0.67	1.00	1.35	1.70	2.0	
		5A	0.3	6.4			0.03	0.05	0.08	0.13	0.25	0.43	0.64	0.85	1.06	1.2	
		6A	0.3	6.4			0.01	0.03	0.04	0.07	0.14	0.24	0.35	0.46	0.59	0.8	
1-1/2"	40	FC	1.2	30.0	0.8	20	0.45	1.12	2.00	3.07	5.91	10.57	16.18	21.57	25.66	28.0	
		1A	0.8	21.5			0.23	0.58	1.06	1.69	3.16	5.36	7.97	10.69	13.44	16.0	
		2A	0.6	16.0			0.20	0.44	0.71	1.02	1.88	3.25	4.93	6.71	8.59	10.5	
		3A	0.5	12.5			0.09	0.22	0.40	0.62	1.13	2.02	3.17	4.26	5.21	6.0	
		4A	0.4	10.0			0.05	0.14	0.26	0.41	0.79	1.36	2.08	2.83	3.45	4.0	
		5A	0.3	7.0			0.03	0.08	0.13	0.21	0.39	0.69	1.07	1.43	1.74	2.2	
		6A	0.3	6.4			0.03	0.06	0.09	0.13	0.23	0.40	0.59	0.78	0.98	1.2	
2"	50	FC	1.7	43.9	0.8	20	1.21	2.46	3.31	5.12	9.42	16.83	26.55	36.59	44.52	49.0	
		1A	1.3	33.4			0.32	0.82	1.51	2.87	5.48	9.31	13.77	18.31	23.17	28.0	
		2A	0.8	21.5			0.17	0.47	0.88	1.63	3.18	5.47	8.21	11.09	13.68	17.0	
		3A	0.6	16.0			0.15	0.37	0.66	1.02	1.89	3.29	5.01	6.71	8.41	10.0	
3"	80	FC	2.8	72.0	1.5	40	2.01	4.47	7.37	12.28	22.52	38.62	62.02	79.57	90.09	100.0	
		1A	1.9	47.0			1.00	2.51	4.50	6.96	12.95	23.65	36.15	47.82	58.70	70.0	
		2A	1.3	34.0			0.73	1.61	2.64	3.95	7.53	13.57	21.26	28.97	34.99	42.0	
		3A	1.0	25.0			0.36	0.89	1.59	2.46	4.51	8.08	12.55	16.82	20.78	25.0	
4"	100	FC	3.6	91.5	1.5	40	2.90	6.72	11.48	17.16	29.35	56.26	86.65	120.90	153.84	190.0	
		1A	2.4	60.0			1.56	3.77	6.63	10.11	18.42	32.83	55.27	77.53	98.63	120.0	
		2A	1.7	43.0			1.45	3.05	4.82	8.10	14.86	24.20	35.22	49.81	61.14	72.0	
		3A	1.3	32.0			0.88	1.82	2.84	4.44	8.42	14.38	21.12	27.79	34.17	42.0	
6"	150	FC	4.5	115.0	2.4	60	4.23	9.72	16.43	25.73	49.58	89.69	140.01	195.77	256.78	295.0	
		1A	3.0	75.0			2.83	6.73	11.68	17.72	31.53	53.90	88.75	113.11	140.55	165.0	
		2A	1.8	46.5			1.36	3.61	6.68	10.62	17.82	28.66	42.88	57.38	71.53	85.0	
		3A	1.4	35.5			0.91	1.90	2.95	4.26	7.77	13.68	21.42	29.72	37.96	50.0	

NOTE
 cv: Valve flow coefficient
 FL: Liquid pressure recovery factor
 FC: Full Capacity
 3A: 3-Step reduction
 6A: 6-Step reduction"

1A: 1-Step reduction
 4A: 4-Step reduction

2A: 2-Step reduction
 5A: 5-Step reduction

Contoured Trim (with Tendril 1)

ANSI Class: 150# ~ 1500#

Valve Travel [%]							10	20	30	40	50	60	70	80	90	100				
F _L							0,95	0,95	0,95	0,94	0,94	0,94	0,93	0,93	0,91	0,91				
Valve Size		Orifice Dia.			Travel		Rated Cv													
Inch	mm	Sign	Inch	mm	Inch	mm														
1/2"	15	FT	0.6	15.7	0.8	20	0.53	1.27	1.95	2.66	3.38	4.09	4.76	5.51	6.67	7.0				
		1T	0.4	11.0			0.36	0.74	1.23	1.61	1.99	2.37	2.72	3.05	3.41	4.0				
		2T	0.3	8.0			0.28	0.53	0.79	1.07	1.32	1.52	1.71	1.88	2.03	2.3				
		3T	0.3	6.4			0.19	0.36	0.52	0.67	0.82	0.97	1.15	1.28	1.38	1.5				
		4T	0.3	6.4			0.09	0.17	0.25	0.32	0.40	0.47	0.54	0.61	0.68	0.8				
		5T	0.3	6.4			0.06	0.11	0.15	0.20	0.25	0.30	0.35	0.40	0.45	0.5				
3/4"	20	FT	0.7	17.2	0.8	20	0.85	1.68	2.57	3.31	4.04	4.74	5.43	6.18	7.61	9.0				
		1T	0.5	13.0			0.35	0.82	1.40	2.17	2.78	3.39	3.98	4.53	5.03	5.5				
		2T	0.4	9.0			0.29	0.74	1.08	1.40	1.73	2.13	2.37	2.60	2.80	3.0				
		3T	0.3	7.2			0.24	0.44	0.63	0.81	0.99	1.16	1.32	1.47	1.62	2.0				
		4T	0.3	6.4			0.13	0.24	0.36	0.48	0.60	0.72	0.84	0.96	1.08	1.2				
		5T	0.3	6.4			0.08	0.15	0.22	0.28	0.35	0.42	0.49	0.56	0.63	0.7				
1"	25	FT	0.9	22.3	0.8	20	1.29	2.62	4.02	5.42	6.83	8.13	8.90	10.25	11.93	13.5				
		1T	0.6	15.0			0.77	1.54	2.31	3.15	3.92	4.68	5.42	6.12	7.00	8.5				
		2T	0.5	11.5			0.46	0.94	1.43	1.94	2.46	3.02	3.52	4.00	4.44	5.4				
		3T	0.4	9.0			0.28	0.56	0.86	1.16	1.47	1.77	2.07	2.36	2.66	3.1				
		4T	0.3	7.2			0.18	0.37	0.57	0.78	0.99	1.20	1.41	1.61	1.79	2.0				
		5T	0.3	6.4			0.11	0.23	0.35	0.47	0.59	0.71	0.83	0.95	1.07	1.2				
1-1/2"	40	FT	1.2	30.0	0.8	20	2.64	5.38	8.46	11.77	15.22	18.77	21.56	24.09	26.50	28.0				
		1T	0.8	21.5			1.63	3.16	4.70	6.25	7.90	9.52	11.12	12.68	14.18	16.0				
		2T	0.6	16.0			0.95	1.89	2.86	3.86	4.88	5.88	6.90	7.92	8.86	10.5				
		3T	0.5	12.5			0.57	1.13	1.72	2.33	2.96	3.58	4.19	4.78	5.33	6.0				
		4T	0.4	10.0			0.37	0.74	1.14	1.54	1.96	2.38	2.79	3.18	3.55	4.0				
		5T	0.3	7.0			0.19	0.38	0.57	0.78	0.99	1.19	1.40	1.60	1.78	2.2				
2"	50	FT	1.7	43.9	0.8	20	4.13	9.24	14.48	19.71	25.09	30.56	35.97	40.01	44.64	49.0				
		1T	1.3	33.4			2.27	4.97	7.88	10.94	13.72	16.51	19.28	22.03	24.97	28.0				
		2T	0.8	21.5			1.26	2.76	4.37	6.05	7.77	9.53	11.23	12.73	14.32	17.0				
		3T	0.6	16.0			0.82	1.78	2.80	3.86	4.93	5.98	7.01	7.98	8.89	10.0				
		3"	80	FT			2.8	72.0	1.5	40	9.96	21.06	32.40	42.65	52.98	63.70	76.67	86.07	91.15	100.0
				1T			1.9	47.0			5.35	11.64	18.74	26.58	33.66	40.46	47.18	53.74	60.34	70.0
2T	1.3			34.0	3.47	7.21	11.20	15.38			19.69	24.06	28.45	31.99	35.66	42.0				
3T	1.0			25.0	2.17	4.47	6.86	9.32			11.81	14.29	16.73	19.08	21.29	25.0				
4"	100			FT	3.6	91.5	1.5	40			12.67	27.12	47.27	66.04	85.99	106.88	127.85	147.47	167.93	190.0
				1T	2.4	60.0					7.32	15.77	25.33	36.43	51.05	63.30	75.78	88.32	103.94	120.0
		2T	1.7	43.0	7.02	13.84			20.64	27.41	34.07	43.44	50.85	57.09	63.09	72.0				
		3T	1.3	32.0	4.03	8.16			12.45	16.82	21.18	25.44	29.51	33.31	37.67	42.0				

NOTE
 cv: Valve flow coefficient
 FL: Liquid pressure recovery factor
 FT: Full Capacity
 1T: 1-Step reduction
 2T: 2-Step reduction
 3T: 3-Step reduction
 4T: 4-Step reduction
 5T: 5-Step reduction
 6T: 6-Step reduction

GU, Valve dimensions and weights

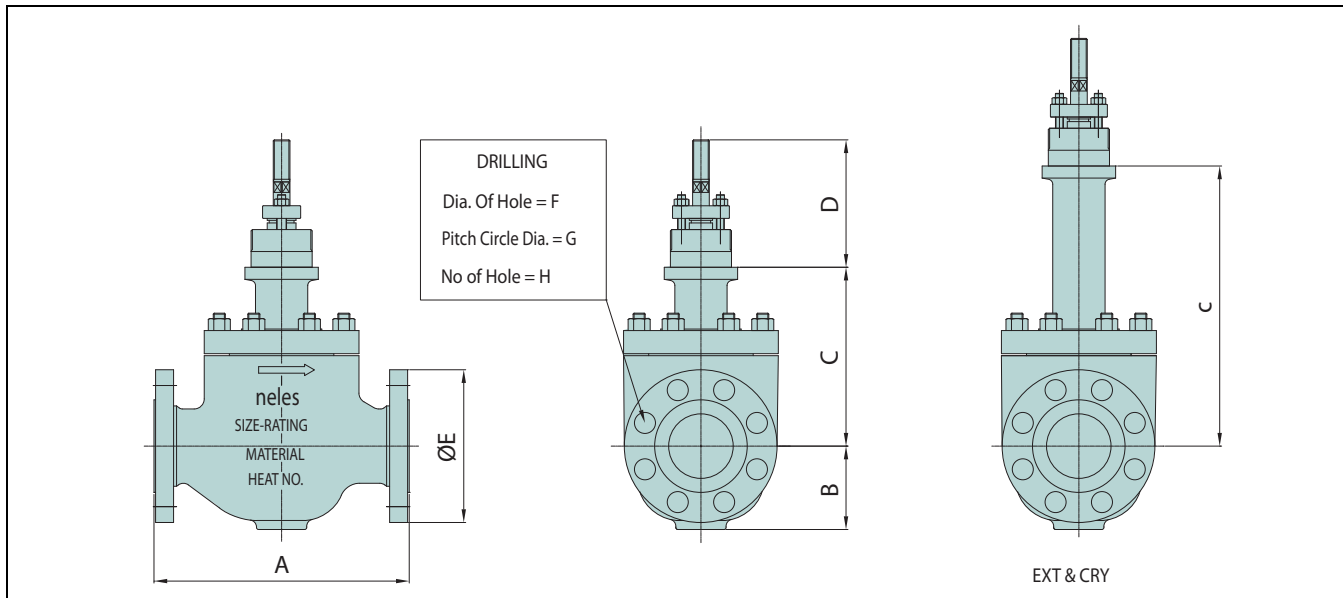

150 # / 300 # / 600 #

Dimension (mm)	A			B			C			D	E			F			G			H			Weight (kg) (Approximte)		
	150#	300#	600#	150#	300#	600#	STD	EXT	CRY	COMMON	150#	300#	600#	150#	300#	600#	150#	300#	600#	150#	300#	600#	150#	300#	600#
15	184	190	203	44.5	47.5	47.5	142	250	400	110	90	95	95	15.9	15.9	15.9	60.3	66.7	66.7	4	4	4	14	15	23
20	184	194	206	49	57.5	57.5	142	250	400	110	100	115	115	15.9	19.1	19.1	69.9	82.6	82.6	4	4	4	14	15	23
25	184	197	210	55	63	63	142	250	400	110	110	125	125	15.9	19.1	19.1	79.4	88.9	88.9	4	4	4	14	15	23
40	222	235	251	65	78	78	161	269	419	110	125	155	155	15.9	22.2	22.2	98.4	114.3	114.3	4	4	4	22	23	27
50	254	267	286	83	83	83	178	333	458	110	150	165	165	19.1	19.1	19.1	120.7	127	127	4	8	8	25	27	32
80	298	318	337	109	109	120	222	395	545	115	190	210	210	19.1	22.2	22.2	152.4	168.3	168.3	4	8	8	55	57	62
100	352	368	394	135	135	135	248	402	552	140	230	255	275	19.1	22.2	25.4	190.5	200	215.9	8	8	8	80	83	92

Dimension (inch)	A			B			C			D	E			F			G			H			Weight (lbs) (Approximte)		
	150#	300#	600#	150#	300#	600#	STD	EXT	CRY	COMMON	150#	300#	600#	150#	300#	600#	150#	300#	600#	150#	300#	600#	150#	300#	600#
1/2"	7.24	7.48	7.99	1.75	1.87	1.87	5.59	9.84	15.74	4.33	3.54	3.74	3.74	0.63	0.63	0.63	2.37	2.63	2.63	4	4	4	31	33	51
3/4"	7.24	7.64	8.11	1.93	2.26	2.26	5.59	9.84	15.74	4.33	3.94	4.53	4.53	0.63	0.75	0.75	2.75	3.25	3.25	4	4	4	31	33	51
1"	7.24	7.76	8.27	2.17	2.48	2.48	5.59	9.84	15.74	4.33	4.33	4.92	4.92	0.63	0.75	0.75	3.13	3.5	3.5	4	4	4	31	33	51
1-1/2"	8.74	9.25	9.88	2.56	3.07	3.07	6.34	10.59	16.49	4.33	4.92	6.1	6.1	0.63	0.87	0.87	3.87	4.5	4.5	4	4	4	49	51	60
2"	10	10.51	11.26	3.27	3.27	3.27	7.01	13.11	18.03	4.33	5.91	6.5	6.5	0.75	0.75	0.75	4.75	5	5	4	8	8	55	60	71
3"	11.73	12.52	13.27	4.29	4.29	4.72	8.74	15.55	21.45	4.53	7.48	8.27	8.27	0.75	0.87	0.87	6	6.63	6.63	4	8	8	121	126	137
4"	13.86	14.49	15.51	5.31	5.31	5.31	9.76	15.82	21.73	5.51	9.06	10.04	10.83	0.75	0.87	1	7.5	7.87	8.5	8	8	8	176	183	203

NOTE
P.C.D = Pitch Circle Diameter

900 # / 1500 #

Dimension (mm)	A		B		C		D	E		F		G		H		Weight (kg) (Approximte)	
	900#	1500#	900#	1500#	STD	EXT	COMMON	900#	1500#	900#	1500#	900#	1500#	900#	1500#	900#	1500#
15	292	292	78	78	236	330	150	120	120	22.2	22.2	82.6	82.6	4	4	60	60
20	292	292	78	78	236	330	150	130	130	22.2	22.2	88.9	88.9	4	4	60	60
25	292	292	82	82	236	330	150	150	150	25.4	25.4	101.6	101.6	4	4	60	60
40	333	333	100	100	240	380	150	180	180	28.5	28.5	123.8	123.8	4	4	63	63
50	375	375	113	113	240	380	225	215	215	25.4	25.4	165.1	165.1	8	8	67	67
80	441	460	142	142	322	430	225	240	265	25.4	31.7	190.5	203.2	8	8	150	163

Dimension (inch)	A		B		C		D	E		F		G		H		Weight (lbs) (Approximte)	
	900#	1500#	900#	1500#	STD	EXT	COMMON	900#	1500#	900#	1500#	900#	1500#	900#	1500#	900#	1500#
1/2"	11.5	11.5	3.07	3.07	9.29	13	5.9	4.72	4.72	0.87	0.87	3.25	3.25	4	4	132	132
3/4"	11.5	11.5	3.07	3.07	9.29	13	5.9	5.12	5.12	0.87	0.87	3.5	3.5	4	4	132	132
1"	11.5	11.5	3.23	3.23	9.29	13	5.9	5.91	5.91	1	1	4	4	4	4	132	132
1-1/2"	13.11	13.11	3.94	3.94	9.45	15	5.9	7.09	7.09	1.12	1.12	4.87	4.87	4	4	139	139
2"	14.76	14.76	4.45	4.45	9.45	15	8.86	8.46	8.46	1	1	6.5	6.5	8	8	148	148
3"	17.36	18.11	5.59	5.59	13.19	17	8.86	9.45	10.43	1	1.25	7.5	8	8	8	331	359

NOTE
P.C.D = Pitch Circle Diameter

VD Diaphragm actuators Actuator dimensions

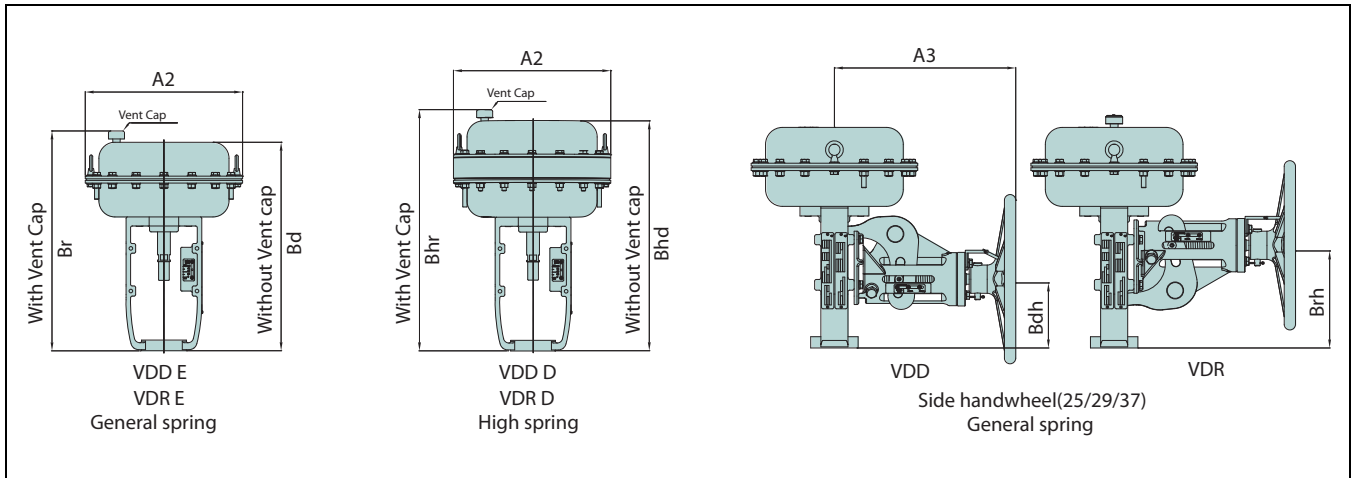

Dimension (mm)	Without handwheel				With handwheel				
	Size (mm)	A2	Bd / Bhd	Br / Bhr	Weight (kg)	A2	A3	Bdh	Brh
VD_25 E	255	348	373	12	255	312	110	170	23
VD_25 D	255	373	395	17					
VD_29 E	295	391	416	18	295	312	122	182	29
VD_29 D	295	431	453	26					
VD_37 E	375	464	489	28	375	352	131	211	43
VD_37 D	375	514	535	46					

Dimension (inch)	Without handwheel				With handwheel				
	Size (inch)	A2	Bd / Bhd	Br / Bhr	Weight (lbs)	A2	A3	Bdh	Brh
VD_25 E	10	14	15	26	10	12	4	7	51
VD_25 D	10	15	16	37					
VD_29 E	12	15	16	40	12	12	5	7	64
VD_29 D	12	17	18	57					
VD_37 E	15	18	19	62	15	14	5	8	95
VD_37 D	15	20	21	101					

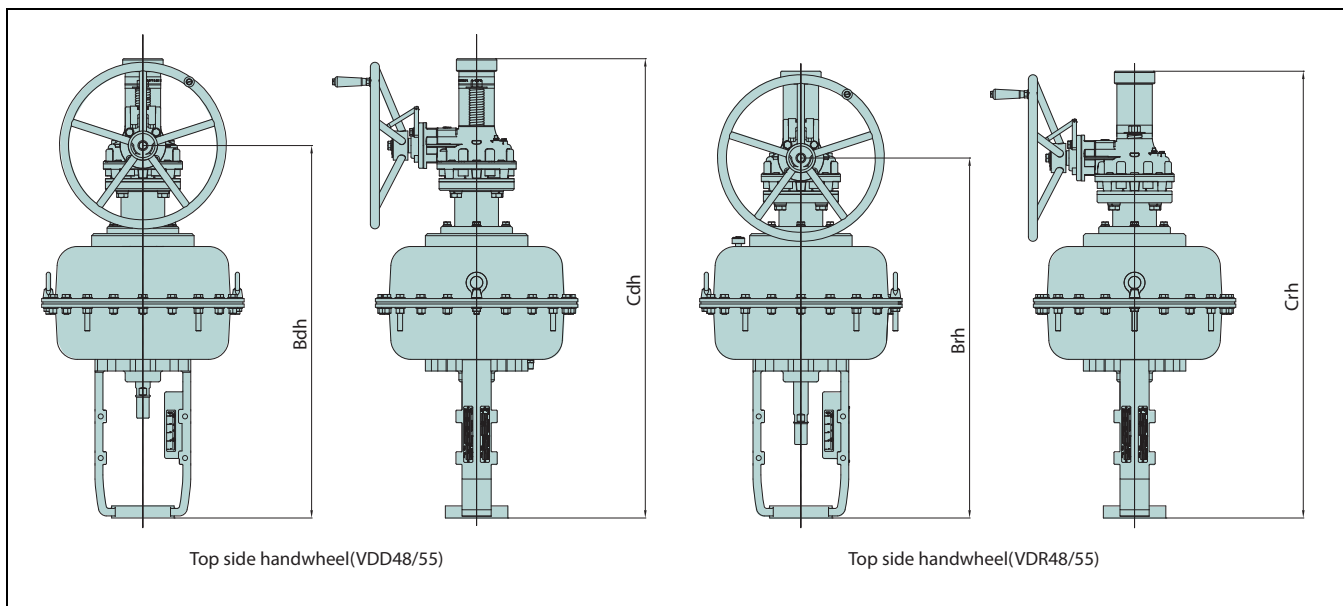

Dimension (mm)	Without handwheel				With handwheel				
	Size (mm)	A2	Bd / Bhd	Br / Bhr	Weight (kg)	Bdh	Brh	Cdh	Crh
VD_48 E	486	652	677	86	896	865	1102	1072	112
VD_48 D	486	702	724	118					
VD_55 E	566	695	720	112	940	910	1145	1115	145
VD_55 D	566	745	767	152					

Dimension (inch)	Without handwheel				With handwheel				
	Size (inch)	A2	Bd / Bhd	Br / Bhr	Weight (lbs)	Bdh	Brh	Cdh	Crh
VD_48 E	19	26	27	190	35	34	43	42	247
VD_48 D	19	28	29	260					
VD_55 E	22	27	28	247	37	36	45	44	320
VD_55 D	22	29	30	335					

- NOTE
1. "E" refers to Spring range 0.8~2.6
 2. "D" refers to Spring range 1.5~3.4
 3. "Br / Bhr" refers to reverse acting actuator, VDR E / D
 4. "Bd / Bhd" refers to direct acting actuator, VDD E / D
 5. "Cdh / Crh" Top side handwheel actuator, VD_48/55

Actuator dimensions

VC cylinder actuators without handwheel

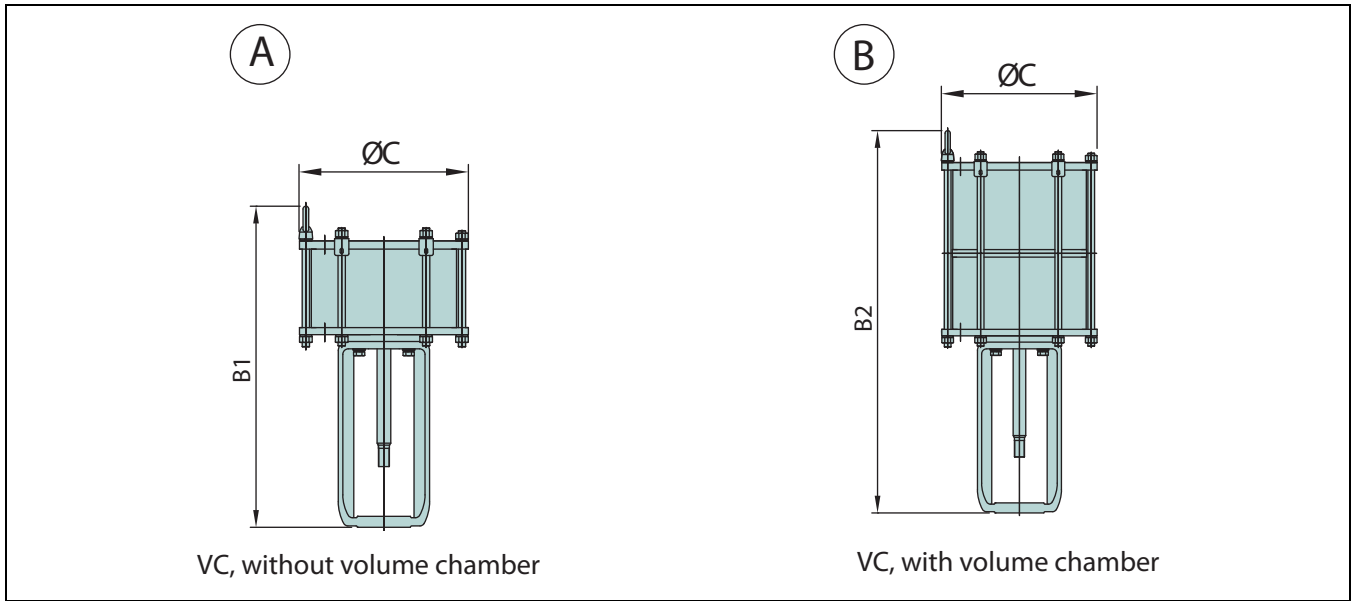

VC actuators without handwheel

Stroke (mm)	#30			#40			#50		
	ØC	370		ØC	460		ØC	560	
	B1	Weight(kg)		B1	Weight(kg)		B1	Weight(kg)	
	B2	A	B	B2	A	B	B2	A	B
40	640	92	115	810	120	148	810	186	234
	760			935			935		
50	650	94	118	820	123	152	820	189	237
	790			965			965		
60	660	97	121	830	126	155	830	192	242
	820			995			995		
70	670	100	124	840	128	159	840	195	246
	850			1025			1025		
80	680	103	127	850	131	162	850	198	251
	880			1055			1055		
90	690	106	130	860	134	166	860	201	256
	910			1085			1085		
100	700	108	133	870	137	173	870	203	261
	940			1115			1115		
120	720	114	139	890	142	177	890	209	270
	1000			1175			1175		
140				910	148	184	910	215	279
				1235			1235		
180				950	159	198	950	227	298
				1355			1355		

Stroke (mm)	#60			#70			#80		
	ØC	660		ØC	710		ØC	820	
	B1	Weight(kg)		B1	Weight(kg)		B1	Weight(kg)	
	B2	A	B	B2	A	B	B2	A	B
100	954	255	344	955	322	438	954	378	519
	1199			1203			1207		
120	974	262	355	975	330	450	974	386	531
	1259			1263			1267		
140	994	269	365	995	338	461	994	394	543
	1319			1323			1327		
180	1034	283	386	1035	354	484	1034	410	567
	1439			1443			1447		
240	1094	303	417	1095	377	518	1094	435	604
	1619			1623			1627		
280							1134	451	628
							1747		

VC actuators without handwheel

Stroke (mm)	#30			#40			#50		
	ØC	15		ØC	18		ØC	22	
	B1	Weight(lbs)		B1	Weight(lbs)		B1	Weight(lbs)	
	B2	A	B	B2	A	B	B2	A	B
40	25	203	254	32	265	326	32	410	516
	30			37			37		
50	26	207	260	32	271	335	32	417	522
	31			38			38		
60	26	214	267	33	278	342	33	423	534
	32			39			39		
70	26	220	273	33	282	351	33	430	542
	33			40			40		
80	27	227	280	33	289	357	33	437	553
	35			42			42		
90	27	234	287	34	295	366	34	443	564
	36			43			43		
100	28	238	293	34	302	381	34	448	575
	37			44			44		
120	28	251	306	35	313	390	35	461	595
	39			46			46		
140				36	326	406	36	474	615
				49			49		
180				37	351	437	37	500	657
				53			53		

Stroke (mm)	#60			#70			#80		
	ØC	26		ØC	28		ØC	32	
	B1	Weight(lbs)		B1	Weight(lbs)		B1	Weight(lbs)	
	B2	A	B	B2	A	B	B2	A	B
100	38	562	758	38	710	966	37	833	1144
	47			47			48		
120	38	578	783	38	728	992	38	851	1171
	50			50			50		
140	39	593	805	39	745	1016	39	869	1197
	52			52			52		
180	41	624	851	41	780	1067	41	904	1250
	57			57			57		
240	43	668	919	43	831	1142	43	959	1332
	64			64			64		
280							45	994	1385
							69		

Actuator dimensions

VC cylinder actuators with handwheel

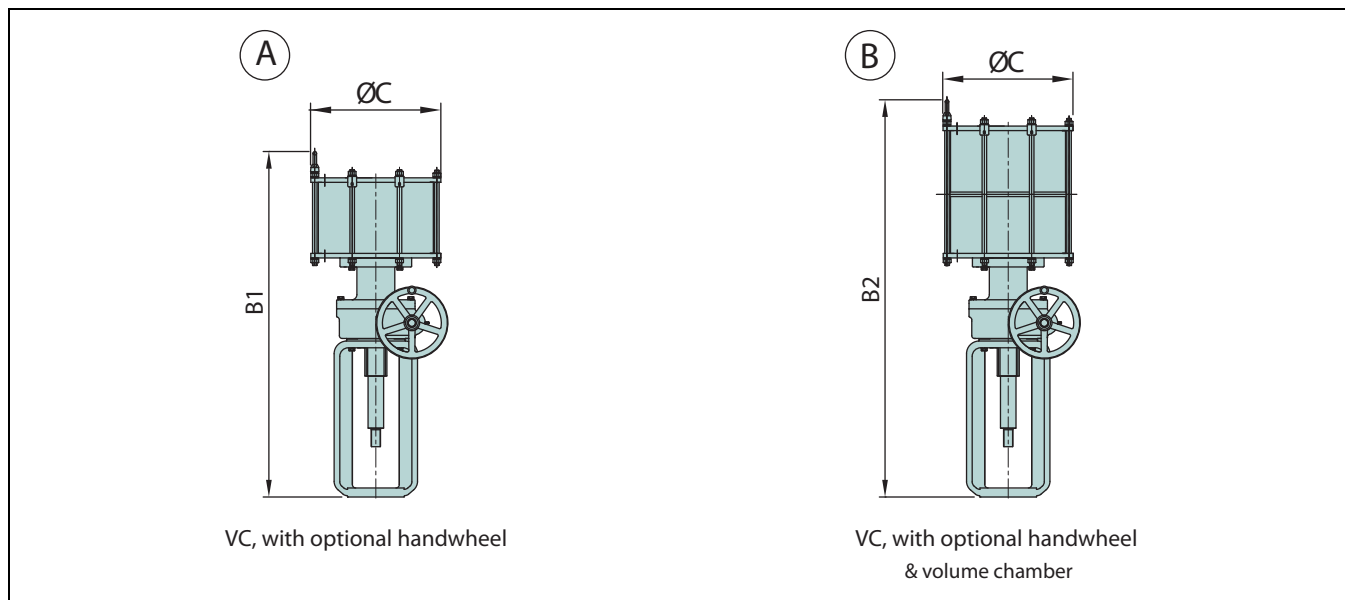

VC actuators with handwheel

Stroke (mm)	#30			#40			#50		
	ØC	370		ØC	460		ØC	560	
	B1	Weight(kg)		B1	Weight(kg)		B1	Weight(kg)	
	B2	A	B	B2	A	B	B2	A	B
40	930	134	157	1095	180	208	1095	246	294
	1055			1220			1220		
50	940	137	160	1105	183	212	1105	249	299
	1085			1250			1250		
60	950	139	163	1115	186	215	1115	252	303
	1115			1280			1280		
70	960	142	167	1125	188	219	1125	255	308
	1145			1310			1310		
80	970	144	170	1135	191	222	1135	258	313
	1175			1340			1340		
90	980	147	173	1145	194	226	1145	261	318
	1205			1370			1370		
100	990	150	176	1155	197	230	1155	263	322
	1235			1400			1400		
120	1010	155	183	1175	202	237	1175	269	332
	1295			1460			1460		
140				1195	208	244	1195	275	341
				1520			1520		
180				1235	219	258	1235	287	360
				1640			1640		

Stroke (mm)	#60			#70			#80		
	ØC	660		ØC	710		ØC	820	
	B1	Weight(kg)		B1	Weight(kg)		B1	Weight(kg)	
	B2	A	B	B2	A	B	B2	A	B
100	1239	315	404	1240	368	502	1289	438	579
	1484			1488			1542		
120	1259	322	415	1260	376	514	1309	446	591
	1544			1548			1602		
140	1279	329	425	1280	384	525	1329	454	603
	1604			1608			1662		
180	1319	343	446	1320	400	548	1369	470	627
	1724			1728			1782		
240	1379	363	477	1380	423	582	1429	495	664
	1904			1908			1962		
280							1469	511	688
							2082		

VC actuators with handwheel

Stroke (mm)	#30			#40			#50		
	ØC	15		ØC	18		ØC	22	
	B1	Weight(lbs)		B1	Weight(lbs)		B1	Weight(lbs)	
	B2	A	B	B2	A	B	B2	A	B
40	37	295	346	43	397	459	43	542	648
	42			48			48		
50	37	302	353	44	403	467	44	549	659
	43			49			49		
60	37	306	359	44	410	474	44	556	668
	44			50			50		
70	38	313	368	44	414	483	44	562	679
	45			52			52		
80	38	317	375	45	421	489	45	569	690
	46			53			53		
90	39	324	381	45	428	498	45	575	701
	47			54			54		
100	39	331	388	45	434	507	45	580	710
	49			55			55		
120	40	342	403	46	445	522	46	593	732
	51			57			57		
140				47	459	538	47	606	752
				60			60		
180				49	483	569	49	633	794
				65			65		

Stroke (mm)	#60			#70			#80		
	ØC	26		ØC	28		ØC	32	
	B1	Weight(lbs)		B1	Weight(lbs)		B1	Weight(lbs)	
	B2	A	B	B2	A	B	B2	A	B
100	49	694	891	49	811	1107	51	966	1276
	58			58			61		
120	50	710	915	50	829	1133	52	983	1303
	61			61			63		
140	50	725	937	50	847	1157	52	1001	1329
	63			63			65		
180	52	756	983	52	882	1208	54	1036	1382
	68			68			70		
240	54	800	1052	54	933	1283	56	1091	1464
	75			75			77		
280							58	1127	1517
							82		

HOW TO ORDER

Globe unbalanced, Top guided type, series GU

1.	2.	3.	4.	5.	6.	7.	8.	9.	10.	11.	12.	13.	14.	15.	16.	17.	18.	19.	20.	21.	22.
GU	01	C	W	A	J2	B	P1	X	BC	S1	R1	X	S	G	X	S	A	X	A	E	FC

VALVE CONSTRUCTIONS

1.	VALVE SERIES
GU	Globe unbalanced, Top guided type

2.	BODY SIZE			
0H	0.5" / DN 15	3Q	0.75" / DN 20	
01	1" / DN 25	1H	1-1/2" / DN 40	
02	2" / DN 50	03	3" / DN 80	
04	4" / DN 100			
Optional body size				
06	6" / DN 150	YY	Special	

3.	PRESSURE RATING			
C	ASME class 150	D	ASME class 300	
F	ASME class 600	K	EN PN 16	
M	EN PN 40			
Optional pressure rating				
G	ASME class 900	H	ASME class 1500	
I	ASME class 2500	N	EN PN 63	
P	EN PN 100	B	EN PN 160	
E	EN PN 250	Y	Special	

- K: available for DN50-DN150- M: available for DN50-DN150

4.	END CONNECTION
W	Flanged RF, ASME B16.5
C	Flanged RF, EN 1092-1
V	Socket welding, ASME B16.11
Q	Butt welding, ASME B16.25
Optional end connection	
Z	Ring joint flange, ASME B16.5
Y	Special

5.	BONNET CONSTRUCTION	
	Bonnet type	Actuator connection
A	General	Applicable for VD_25/29/37
B	General	Applicable for VD_48/55
E	Extension	Applicable for VD_25/29/37
F	Extension	Applicable for VD_48/55
P	Cryogenic	Applicable for VD_25/29/37
Q	Cryogenic	Applicable for VD_48/55
Optional bonnet construction		
J	Bellows seals	Applicable for VD_25/29/37
K	Bellows seals	Applicable for VD_48/55
Y	Special	Special

6.	BODY MATERIAL
J2	A216 gr. WCB
S6	A351 gr. CF8M
Optional body material	
S1	A351 gr. CF3M
YY	Special

- Bonnet material is equivalent with Body material.

7.	MODEL CODE
B	Model B

TRIM CONSTRUCTIONS

8.	PLUG MATERIAL	
	Material	Description
P1	410 SS	General for carbon steel valve
T6	316 SS	General for stainless steel valve
VM	Alloy 6	Use for small Cv and Micro plug
Optional plug material		
S1	316L SS	
YY	Special	Special materials

9.	PLUG APPLICATION
X	Not applicable
A	Cobalt based alloy
Optional plug material	
Y	Special

10.	STEM MATERIAL	
	Material	Description
BC	630 SS + HCr	General for carbon steel valve
TC	316 SS + HCr	General for stainless steel valve
Optional stem material		
FC	316L SS + HCr	
YY	Special	Special materials

11.	SEAT TYPE
S1	Single metal seat
T1	Single soft seat
Optional seat type	
YY	Special

12.	SEAT / RETAINER MATERIAL		
	Seat	Retainer	Guide bushing
R1	CA15 / 410 SS	CB7Cu-1 / 630 SS	AISI 440C
T6	CF8M / 316 SS	CF8M / 316 SS	AISI 316 + Alloy 6
V6	Alloy 6	CF8M / 316 SS	AISI 316 + Alloy 6
Optional Seat / Retainer Material			
R2	420J2 SS	CB7Cu-1 / 630 SS	AISI 440C
V6	316 SS	316 SS	AISI 316 + Alloy 6
YY	Special	Special	Special

- AISI 410 is general for carbon steel valve.

- AISI 316 is general for stainless steel valve.

13.	SEAT APPLICATION
X	Not applicable
A	Cobalt based alloy
P	Insert PTFE
Q	Insert PTFE + Cobalt based alloy
Optional seat application	
Y	Special

OTHERS

14.	PACKING / BELLOWS TYPE
S	General packing
E	Low emission, Live loaded
Optional Packing / Bellows Type	
C	Bellows Seal (304 SS, Formed)
Y	Special

15.	PACKING MATERIAL
G	PTFE + Carbon fiber
F	Graphite
T	PTFE V-Ring
Optional packing material	
H	Hi-Graphite
Y	Special

16.	SEAL RING MATERIAL
X	Not applicable

17.	GASKET MATERIAL
S	S/W gasket type, 316L SS + Graphite for general
L	S/W gasket type, 316L SS + PTFE
Optional gasket material	
H	S/W gasket type, 316L SS + Graphite for high temp.
Y	Special

18.	STUD / NUT MATERIAL
A	A193 gr. B7 / A194 gr. 2H
B	A193 gr. B8 / A194 gr. 8
K	A320 gr. B8M cl. 2 / A194 gr. 8M
Optional stud / Nut material	
H	A193 gr. B16 / A194 gr. 4
Y	Special

19.	OPTIONS
X	Not applicable
E	Anti-erosion
Special options	
L	Lub. & Isol. valve
W	Water seal
Y	Special

* Face to face length according to ISA 75.08

* The body, bonnet, trim materials are subject to change as equivalent depending on detail design.

* Please see 'Neles Globe Typecode Instruction' for further options.

TRIM TYPE & RATED Cv

20. Sign	TRIM TYPE	21. Sign	TRIM CHARACTERISTIC	22. Sign	DESCRIPTION	RATED Cv														
						BODY SIZE AND STROKE														
						1/2" Str.	3/4" Str.	1" Str.	1-1/2" Str.	2" Str.	3" Str.	4" Str.	6" Str.							
A	General plug type	L	Linear	FC	Full capacity	7 (20)	9 (20)	13.5 (20)	28 (20)	49 (20)	100 (40)	190 (40)	295 (60)							
					1A	1-Step reduction	4 (20)	5.5 (20)	8.5 (20)	16 (20)	28 (20)	70 (40)	120 (40)	165 (60)						
					2A	2-Step reduction	2.3 (20)	3 (20)	5.4 (20)	10.5 (20)	17 (20)	42 (40)	72 (40)	85 (60)						
					3A	3-Step reduction	1.5 (20)	2 (20)	3.1 (20)	6 (20)	10 (20)	25 (40)	42 (40)	50 (60)						
					4A	4-Step reduction	0.8 (20)	1.2 (20)	2 (20)	4 (20)										
					5A	5-Step reduction	0.5 (20)	0.7 (20)	1.2 (20)	2.2 (20)										
		E	Equal %	6A	6-Step reduction	0.3 (20)	0.4 (20)	0.8 (20)	1.2 (20)											
					L	Linear	FT	Tendril 1 / Full capacity	7 (20)	9 (20)	13.5 (20)	28 (20)	49 (20)	100 (40)	190 (40)					
								E	Equal %	1T	Tendril 1 / 1-Step reduction	4 (20)	5.5 (20)	8.5 (20)	16 (20)	28 (20)	70 (40)	120 (40)		
											2T	Tendril 1 / 2-Step reduction	2.3 (20)	3 (20)	5.4 (20)	10.5 (20)	17 (20)	42 (40)	72 (40)	
												3T	Tendril 1 / 3-Step reduction	1.5 (20)	2 (20)	3.1 (20)	6 (20)	10 (20)	25 (40)	42 (40)
											4T	Tendril 1 / 4-Step reduction	0.8 (20)	1.2 (20)	2 (20)	4 (20)				
											5T	Tendril 1 / 5-Step reduction	0.5 (20)	0.7 (20)	1.2 (20)	2.2 (20)				
											6T	Tendril 1 / 6-Step reduction	0.3 (20)	0.4 (20)	0.8 (20)	1.2 (20)				
C	Micro plug type	L	Linear	FC							Full capacity	0.1 (20)	0.1 (20)	0.1 (20)						
					1A	1-Step reduction	0.06 (20)				0.06 (20)	0.06 (20)								
					2A	2-Step reduction	0.03 (20)	0.03 (20)	0.03 (20)											
					3A	3-Step reduction	0.01 (20)	0.01 (20)	0.01 (20)											
					4A	4-Step reduction	0.006 (20)	0.006 (15)	0.006 (20)											
					5A	5-Step reduction	0.003 (20)	0.003 (15)	0.003 (20)											
Y	Special	Y	Special	YY	Special	Contact Metso Korea for Cv details														

* Rated Cv is separated depending on the trim type & trim characteristic.

* Optional rated Cv to meet to specific Cv are available.

* (Str) is the valve stroke.

* For trims without the specified Cv values, please contact Metso Korea.

Metso Corporation

Töölönlahdenkatu 2, PO Box 1220, 00100 Helsinki, Finland

Tel. +358 20 484 100

<http://contact.metso.com/>

Metso Flow Control Inc.

Vanha Porvoontie 229, P.O. Box 304, FI-01301 Vantaa, Finland.

Tel. +358 20 483 150. Fax +358 20 483 151

www.metso.com/valves

Subject to change without prior notice. Product names in this bulletin are all trademarks of Metso Flow Control Inc.

