

## SERIES GB CONTROL VALVES GLOBE-CAGE BALANCED, CAGE GUIDED

Metso's Neles series GB cage guided, balanced trim globe valves are economical high performance control valves designed to provide the best possible control accuracy and wide rangeability with all the inherent benefits of linear control valves. Standard units are equipped with spring diaphragm actuators and ND intelligent valve controllers for precise flow control, extended operational life and performance monitoring on-line.

### Construction

- Compact and lightweight construction
- Large range of trims with different Cv and characteristics per body size to fit many process conditions
- Both metal and soft seats are available depending on the application
- Optional bellows seal for toxic or other applications where no stem seal leakage is allowed
- Wide material selection for different applications
- Many end connection styles available for different applications
- Extension bonnet design for wide temperature range

### Accurate control

- Stable control with good rangeability
- ND9000 or NDX digital valve controller for auto-calibration and accurate control
- Accurate and sensitive diaphragm and piston actuators

### Wide range of applications

- Suitable for gas, liquid and steam
- Temperature limits -29 ... +260 °C / (-20 ... +500 °F) with standard bonnet construction and over +260 °C (+500 °F) and under -29 °C / (-20 °F) with extended bonnets
- Large variation of trim designs from standard cage to Tendril 1 or Tendril 2 for low noise and anti-cavitation applications
- Pilot balanced trim for ANSI class V leakage requirements in high temperature application
- Various seat and seal ring options for wide range of applications

### Design application flexibility

- Wide range of applicable noise control components, silencers, baffle plates
- Inherently characterized trims offered in equal percentage, linear
- Large range of Cvs per body size allowing for wide applicable in process conditions
- High integrity cage guiding system and clamped cage for heavy duty guiding on severe service applications
- Low emission packings available

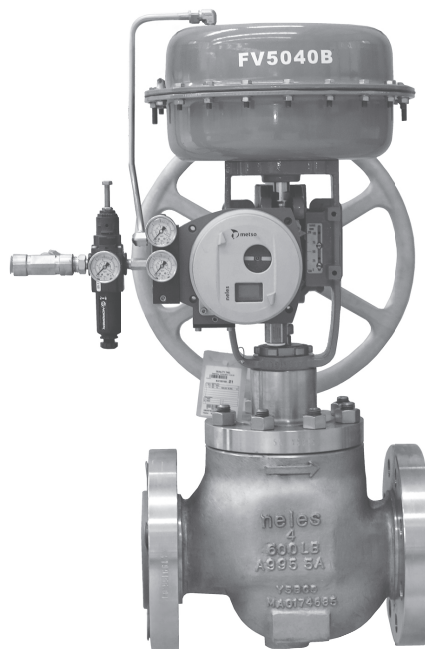

### Safety and quality

- Rugged one piece body to minimize the leak paths and makes the valve less prone to pipe stress
- Strictly tested to ensure specified performance with quality assurance systems in accordance to ISO 9001
- Certified ISO 15848 fugitive emissions
- Certified CE/PED & ATEX, TSG & EAC (GOST-R)

### Easy maintenance

- Quick change trim and top entry construction for easy in-line maintenance
- Self guided components makes for easy valve assembly
- Flow characteristics can be easily changed with interchangeable trim components
- ND digital valve controller with online diagnostics enables performance follow up and predictive maintenance
- Efficient asset management with Metso FieldCare open architecture software and excellent networking capabilities

**Different trim designs**

**Standard cage trim**

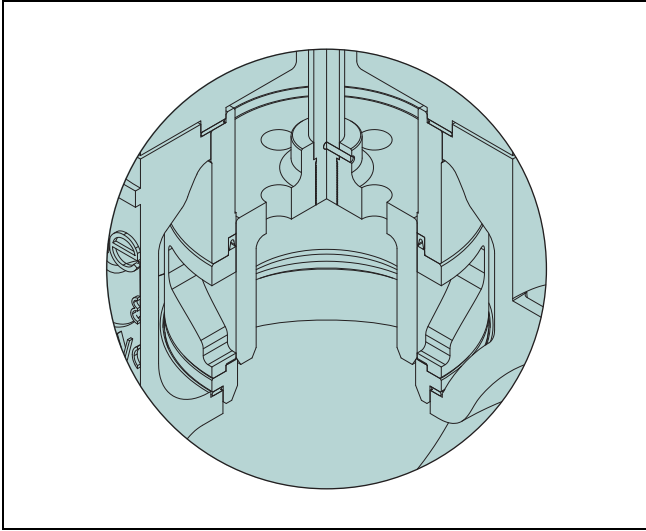

Quick change, standard cage trim

The standard cage trim is designed with a specially designed window shape cage and balanced plug. The window shape defines the flow path through the valve and the flow characteristic of the valve (linear, equal percentage, others ).

The balancing holes are located in the top of the plug. This trim is suited for both high and low pressure drop application and is used in the majority of control applications.

**Tendril(Multi-hole)trim**

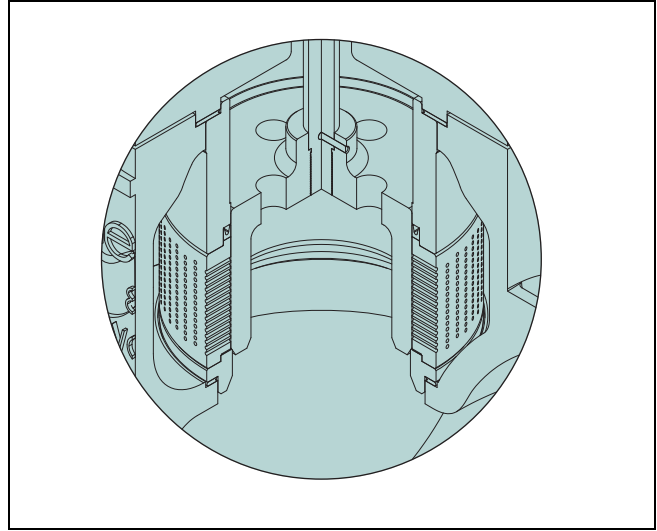

Tendril(Multi-hole)trim

The trim design presented a multi-hole trim. There are Tendril 1 or Tendril 2 designs in standard depending on pressure drop and potential for cavitation.

The pressure drop is divided by multi-holes so that the pressure progressively reduces as it passes through the trim. This gives excellent resistance to cavitation on high pressure drop applications.

**GB, Cage construction**

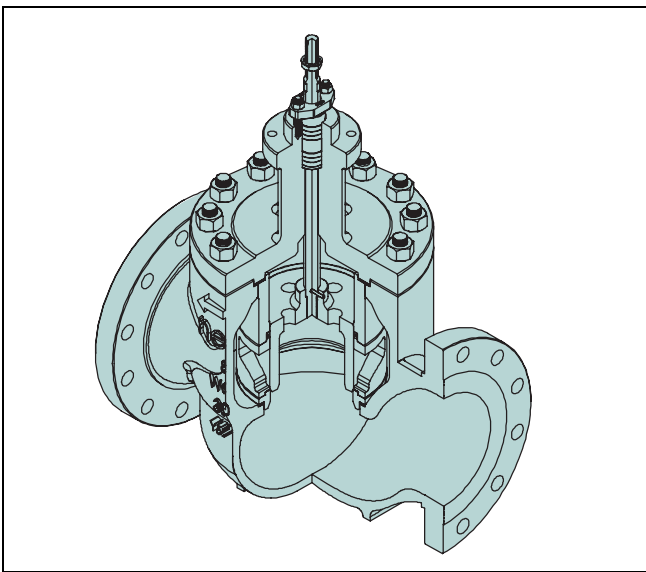

**GB, Tendril construction**

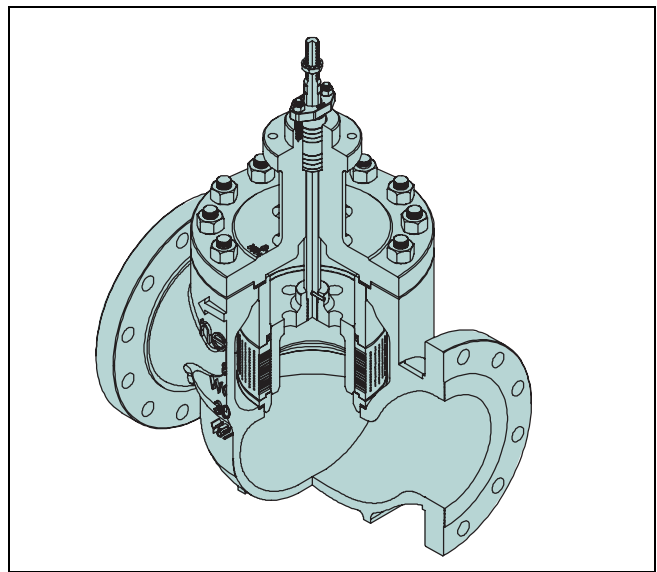

### Pilot balanced trim construction

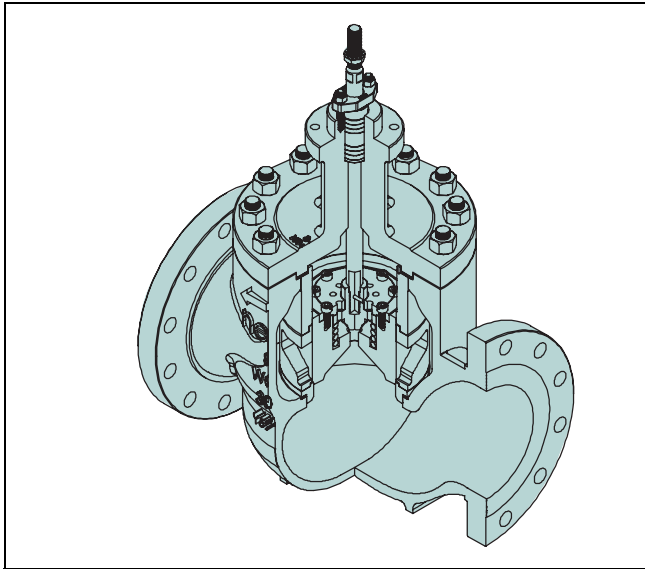

Pilot balanced trim

Pilot balanced trim construction is designed with a special pilot plug & seat built-in the main plug. The design is applicable both 'conventional cage' and Tendril trim. This design gives excellent seat tightness to leakage on high pressure drop and high temperature applications. The design helps to achieve seat leakage class V in high temperature services.

### Components & materials

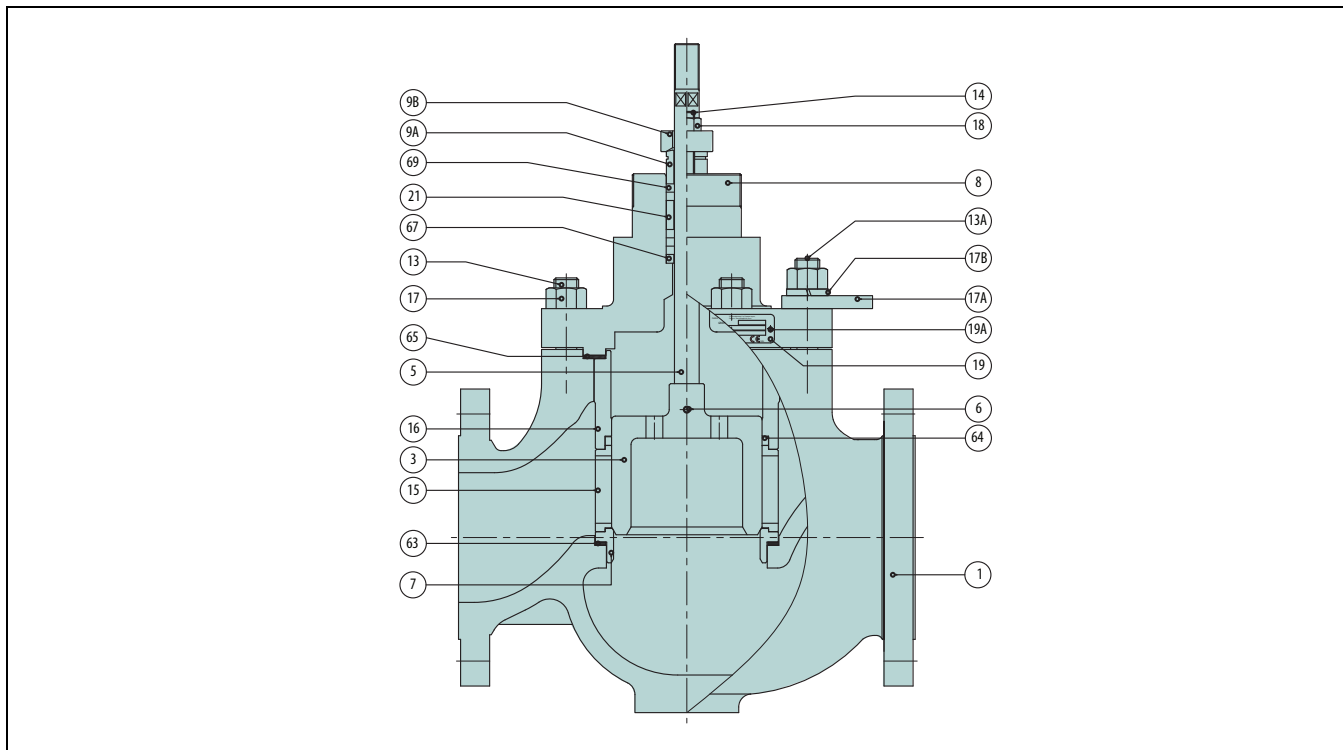

Part no.	Description	Material
1	BODY	A216 WCB / ALLOY STEEL AVAILABLE
2	PLUG SET	410 SS / 630 SS + HCr
3*	PLUG	410 STAINLESS STEEL
5*	STEM	630 STAINLESS STEEL + HCr
6*	PLUG PIN	316 STAINLESS STEEL
7	SEAT RING	410 STAINLESS STEEL
8	BONNET	A216 WCB / ALLOY STAINLESS STEEL
9A	GLAND	304 STAINLESS STEEL
9B	GLAND FLANGE	A351 CF8
13 / 13A	STUD	A193 Gr.B7
14	STUD	A193 Gr.B8
15	CAGE	630 STAINLESS STEEL + HCr
16	CAGE GUIDE	630 STAINLESS STEEL + HCr
17	HEXAGON NUT	A194 Gr.2H
17A	LIFTING PLATE	JIS G3101-SS400
17B	SPRING WASHER	AISI 304
18	HEXAGON NUT	A194 Gr.8
19	IDNTIFICATION PLATE	304 STAINLESS STEEL
19A	RIVET	304 STAINLESS STEEL
21	LANTERN RING	304 STAINLESS STEEL
63	SEAT GASKET	S/W GASKET, 316 SS + GRAPHITE
64	SEAL RING	PTFE + GRAPHITE
65	BODY GASKET	S/W GASKET, 316 SS + GRAPHITE
67	PACKING SPACER	304 STAINLESS STEEL
69	PACKING RING	PTFE + CARBON FIBER

Part no.	Material	Spare
1	A351 CF8M	
2	316 SS + HCr / 316 SS + HCr	
3*	316 STAINLESS STEEL + HCr	Cat 3
5*	316 STAINLESS STEEL + HCr	Cat 3
6*	316 STAINLESS STEEL	Cat 3
7	316 STAINLESS STEEL	Cat 3
8	A351 CF8M	
9A	304 STAINLESS STEEL	
9B	A351 CF8	
13 / 13A	A193 Gr.B8(M)	
14	A193 Gr.B8	
15	630 STAINLESS STEEL + HCr	Cat 3
16	630 STAINLESS STEEL + HCr	Cat 3
17	A194 Gr.8(M)	
17A	JIS G3101-SS400	
17B	AISI 304	
18	A194 Gr.8	
19	304 STAINLESS STEEL	
19A	304 STAINLESS STEEL	
21	304 STAINLESS STEEL	
63	S/W GASKET, 316 SS + GRAPHITE	Cat 1
64	PTFE + GRAPHITE	Cat 1
65	S/W GASKET, 316 SS + GRAPHITE	Cat 1
67	304 STAINLESS STEEL	
69	GRAPHITE	Cat 1

- Note.
1. Plug/Seat Hard Facing (Cobalt based alloy) & Soft Seat are available
  2. Materials description  
316 SS : ASTM A276 TP316 or JIS 316 St. Steel  
410 SS : ASTM A276 TP410 or JIS 410 St. Steel  
17-4PH : ASTM A564 630(H1100) or JIS 630(H1100) St. Steel
  3. Above standard materials to be applicable depending on specific service conditions. Other optional materials to cons
  4. Optional materials to meet to requirements of NACE MR 01-75 are available
  5. The materials are subject to change as equivalent depending on detail design
  6. The part no. 3 , 5 , 6 a\*r\*e deliv\*ered as\*a set with Part no.2

- Note.
1. Plug/Seat Hard Facing (Cobalt based alloy) & Soft Seat are available
  2. Materials description  
316 SS : ASTM A276 TP316 or JIS 316 St. Steel
  3. Above standard materials to be applicable depending on specific service conditions, other optional materials to consult Metso.
  4. Cryogenic application : ASTM A320 B7M & 8M for Studs(13) and Nuts(17)
  5. Optional materials to meet to requirements of NACE MR 01-75 are available
  6. The materials are subject to change as equivalent depending on detail design
  7. The part no. 3 , 5 , 6 ar\*e deliv\*ered as\*a set with Part no.2

## GB, Applications guide

### Temperature range

PTFE + Graphite pressure energized seal with metal seat:	-40...+260 °C
PTFE + Graphite + Carbon pressure energized seal with metal seat:	-29...+320°C
PTFE pressure energized seal with metal seat:	-196...+232 °C
Metal seat:	-196...+593 °C

### Shut-off classification

Class IV with soft seal & metal seat per ANSI FCI 70-2.  
(0.01 % of valve rated capacity).  
Class V with soft seat or pilot balanced plug per ANSI FCI 70-2.

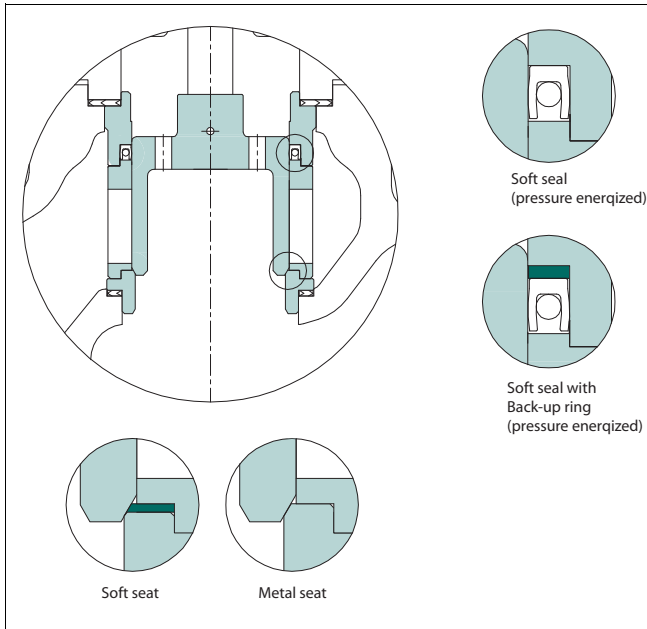

### Temperature range with different body and stud/nut materials

Body, Bonnet Material	Stud Bolt, Nut Application	Temp. Range (°C)	Sign
Carbon steel (WCB, A105)	ASTM A193-B7 STUD ASTM A194-2H NUT	-29 ~ +425	A
Stainless steel (CF3, CF8, CF3M, CF8M)	ASTM A193(320)-B8(M) STUD ASTM A194(320)-8(M) NUT	-196 ~ +593	B
Cr.Mo. Steel (WC6, F11, WC9, F22, C12A, F91)	ASTM A193-B16 STUD ASTM A194-4 NUT	-29 ~ +593	H

\*Please contact Metso

### Trim materials

GB, Trim				Temp. Range (°C)	Sign
Plug	Stem	Seat	Cage		
410 SS	630 SS + HCr	410 SS	630 SS + HCr	-29 ~ +425	P1XBCS1R1X
316 SS	316 SS + HCr	316 SS	316 SS + HCr	-196 ~ +425	T6XTCS1R6X
316 SS + Cobalt based	316 SS + HCr	316 SS + Cobalt based	316 SS + HCr	-196 ~ +425	T6ATCS1R6A
420 J2	630 SS + HCr	420 J2	420 J2	-10 ~ +540	*
316 SS	316 SS + HCr	316 SS + PTFE	316 SS + HCr	-196 ~ +232	*
630 SS	630 SS + HCr	410 SS	410 SS	-29 ~ +425	*
Inconel 718	Inconel 718	F91	F91	-29 ~ +593	*
Inconel 625, 718, 750				-196 ~ +645	*

\*Please contact Metso

### Gasket applications

Body, Bonnet Material	Gasket Material	Temp. Range (°C)	Sign
Carbon steel WCB, A105	S/W (Spiral Wound) 316SS + Graphite	-29 ~ +425	S
Stainless steel CF8, CF8M, CF3, CF3M	S/W (Spiral Wound) 316SS + Graphite	-196 ~ +593	S
	S/W (Spiral Wound) 316SS + PTFE	-196 ~ +232	L
Cr.Mo. Steel WC6, WC9, F22, C12A, F91	S/W (Spiral Wound) 316SS + Graphite + Non Asbestos	-29 ~ +593	H

\*Please contact Metso

### Packing applications

Packing Material	Temp (°C)	Pr. Class	Sign
PTFE + Carbon Fiber (Braided TEF + Graphite)	-196 ~ +260	Up to CL900	G
PTFE V-Ring	-49 ~ +232	Up to CL1600	T
Graphite (with Mold + Braided)	-196 ~ +400	Up to CL2500	F
Hi-Graphite (with Mold + Braided)	-49 ~ +593	Up to CL2500	H
RTFE V ring + Metal	-40 ~ +350	Up to CL600	M

### Flow directions

Series	Cage	General plug				Pilot balanced plug		
		General	Tendril 1 (Gas)	Tendril 1 (Liquid)	Tendril 2 (Gas)	Tendril 2 (Liquid)	General	Tendril 1
GB		FTC	FTO	FTC	FTO	FTC	FTC	FTC

\* FTO: Flow to open  
FTC: Flow to close

**Cv Ratio** 50 : 1  
**Flow Characteristics** Equal percentage, linear

### GB, Ratings & end connections

Valve Size DN / Inch	GB, ASME Ratings										
	Class 150 ~ 600				Class 900 ~ 1500				Class 2500		
	RF	RTJ	SW	BW	RF	RTJ	SW	BW	RF	RTJ	BW
50 / 2	0	0	0	0	0	0	0	0	0	0	0
80 / 3	0	0		0	0	0		0	0	0	0
100 / 4	0	0		0	0	0		0	0	0	0
150 / 6	0	0		0	0	0		0	0	0	0
200 / 8	0	0		0	0	0		0	0	0	0
250 / 10	0	0		0	0	0		0			
300 / 12	0	0		0	0	0		0			
350 / 14	0	0		0	0	0		0			
400 / 16	0	0		0	0	0		0			

\*Note 1. RF: Raised Face Flange, RTJ: Ring Joint, SW: Socket Weld, BW: Butt Weld.  
Bigger sizes are available, please contact Metsso.

### Packing constructions

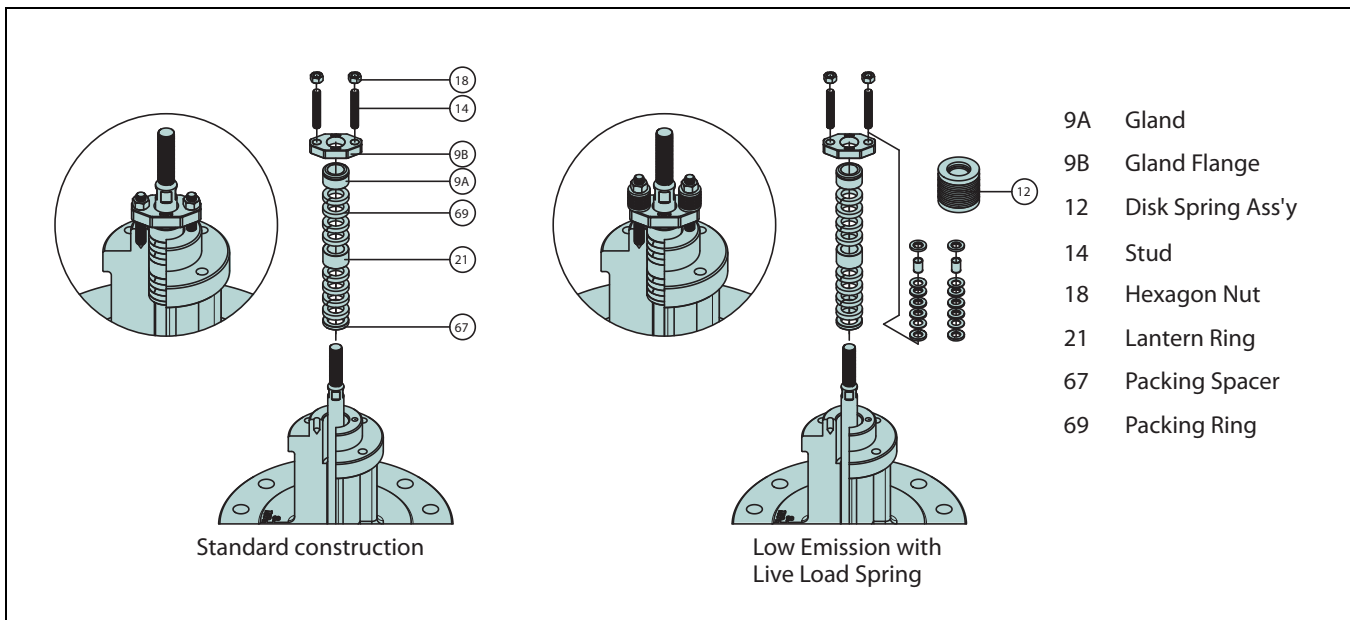

**Rated Cv and trim table (Globe single seat, balanced type, series GB)**

Sign	TRIM TYPE	Sign	TRIM CHARACTERISTIC	Sign	RATED Cv														
					Description	Body Size and Stroke													
						2" Str.	3" Str.	4" Str.	6" Str.	8" Str.	10" Str.	12" Str.	14" Str.	16" Str.					
A P	General plug Pilot balanced plug	L	Linear	FC	General / Full capacity	74 (40)	142 (50)	230 (50)	380 (60)	600 (70)	950 (80)	1270 (120)	1740 (140)	2215 (160)					
				1A	General / 1-Step reduction	48 (40)	98 (50)	160 (50)	275 (60)	455 (70)	700 (80)	970 (120)	1300 (140)	1530 (160)					
				2A	General / 2-Step reduction	26 (40)	56 (50)	86 (50)	150 (60)	254 (70)	398 (80)	550 (120)	776 (140)	940 (160)					
				3A	General / 3-Step reduction	16 (40)	34 (50)	52 (50)	90 (60)	152 (70)	238 (80)	340 (120)	464 (140)	568 (160)					
				FT	Tendril 1 / Full capacity	52 (40)	102 (50)	160 (50)	290 (60)	460 (70)	630 (80)	980 (120)	1300 (140)	1580 (160)					
				1T	Tendril 1 / 1-Step reduction	40 (40)	75 (50)	120 (50)	220 (60)	340 (70)	460 (80)	735 (120)	985 (140)	1145 (160)					
				2T	Tendril 1 / 2-Step reduction	27 (40)	40 (50)	70 (50)	130 (60)	195 (70)	255 (80)	405 (120)	565 (140)	670 (160)					
				3T	Tendril 1 / 3-Step reduction	10 (40)	21 (50)	46 (50)	75 (60)	105 (70)	140 (80)	240 (120)	310 (140)	415 (160)					
				FM	Tendril 2 / Full capacity	50 (40)	100 (50)	155 (50)	280 (60)	425 (70)	590 (80)	920 (120)	1240 (140)	1530 (160)					
				1M	Tendril 2 / 1-Step reduction	35 (40)	74 (50)	115 (50)	215 (60)	330 (70)	450 (80)	720 (120)	970 (140)	1130 (160)					
				2M	Tendril 2 / 2-Step reduction	23 (40)	33 (50)	65 (50)	120 (60)	190 (70)	240 (80)	380 (120)	550 (140)	640 (160)					
				3M	Tendril 2 / 3-Step reduction	8 (40)	18 (50)	38 (50)	67 (60)	100 (70)	130 (80)	220 (120)	290 (140)	390 (160)					
					E	Equal %	FC	General / Full capacity	71 (40)	138 (50)	210 (50)	340 (60)	560 (70)	830 (80)	1240 (120)	1650 (140)	2090 (160)		
							1A	General / 1-Step reduction	50 (40)	110 (50)	160 (50)	270 (60)	450 (70)	655 (80)	960 (120)	1275 (140)	1680 (160)		
							2A	General / 2-Step reduction	24 (40)	50 (50)	82 (50)	136 (60)	236 (70)	374 (80)	524 (120)	746 (140)	854 (160)		
							3A	General / 3-Step reduction	14 (40)	32 (50)	50 (50)	82 (60)	142 (70)	224 (80)	314 (120)	446 (140)	512 (160)		
							FT	Tendril 1 / Full capacity	50 (40)	82 (50)	135 (50)	235 (60)	370 (70)	500 (80)	840 (120)	1110 (140)	1400 (160)		
							1T	Tendril 1 / 1-Step reduction	35 (40)	58 (50)	95 (50)	170 (60)	265 (70)	370 (80)	600 (120)	785 (140)	1020 (160)		
							2T	Tendril 1 / 2-Step reduction	20 (40)	35 (50)	58 (50)	100 (60)	170 (70)	225 (80)	355 (120)	480 (140)	600 (160)		
							3T	Tendril 1 / 3-Step reduction	10 (40)	20 (50)	32 (50)	58 (60)	105 (70)	125 (80)	205 (120)	290 (140)	350 (160)		
				FM	Tendril 2 / Full capacity	47 (40)	74 (50)	130 (50)	230 (60)	330 (70)	470 (80)	770 (120)	1050 (140)	1320 (160)					
				1M	Tendril 2 / 1-Step reduction	33 (40)	56 (50)	92 (50)	165 (60)	245 (70)	330 (80)	570 (120)	720 (140)	960 (160)					
				2M	Tendril 2 / 2-Step reduction	19 (40)	33 (50)	52 (50)	95 (60)	145 (70)	190 (80)	330 (120)	430 (140)	550 (160)					
				3M	Tendril 2 / 3-Step reduction	8 (40)	16 (50)	25 (50)	52 (60)	80 (70)	110 (80)	190 (120)	270 (140)	295 (160)					
Y	Special	Y	Special	YY	Special	Contact Metso for Cv details													

### GB Series Cv vs travel Standard Trim (CAGE)

#### ASME Class: 150# ~ 600#

Size: 2" ~ 16"

Flow Characteristic: LINEAR

Valve Travel [%]							10	20	30	40	50	60	70	80	90	100	
FL							0.94	0.94	0.93	0.93	0.92	0.92	0.91	0.91	0.90	0.90	0.90
Valve Size		Orifice Dia.			Travel		Rated Cv										
Inch	mm	Sign	Inch	mm	Inch	mm											
2	50	FC	2.5	64.5	1.6	40	4.9	13.9	22.2	30.3	39.5	48.6	57.3	64.7	69.5	74	
		1A					3.5	7.6	12.5	17.3	22.4	27.6	33.1	38.5	43.6	48	
		2A					2.6	5.2	7.7	10.3	12.9	15.4	18.0	20.6	23.2	26	
		3A					1.6	3.2	4.8	6.3	7.9	9.5	11.1	12.7	14.3	16	
3	80	FC	3.5	89.0	2.0	50	8.0	22.0	39.0	59.0	75.0	90.0	105.0	119.0	130.0	142	
		1A					6.2	16.6	26.9	36.9	46.6	56.8	67.4	78.0	87.8	98	
		2A					4.5	11.1	16.6	22.2	27.7	33.3	38.8	44.4	49.9	56	
		3A					3.4	6.7	10.1	13.5	16.8	20.2	23.6	26.9	30.3	34	
4	100	FC	4.4	111.5	2.0	50	19.3	41.5	74.4	105.3	133.4	164.5	187.6	206.4	219.3	230	
		1A					8.0	25.4	43.1	60.4	77.2	93.8	110.7	127.6	143.9	160	
		2A					6.0	17.0	25.5	34.1	42.6	51.1	59.6	68.1	76.6	86	
		3A					5.2	10.3	15.4	20.6	25.7	30.9	36.0	41.2	46.3	52	
6	150	FC	5.3	133.6	2.4	60	23.0	62.0	123.5	181.0	229.1	269.3	315.2	349.9	370.1	380	
		1A					12.0	40.9	71.4	101.4	130.6	158.9	186.7	214.7	242.2	275	
		2A					9.5	29.7	44.6	59.4	74.3	89.1	104.0	118.8	133.7	150	
		3A					8.0	17.8	26.7	35.6	44.6	53.5	62.4	71.3	80.2	90	
8	200	FC	6.9	175.5	2.8	70	28.2	94.2	185.6	288.0	377.1	449.1	514.1	571.9	590.0	600	
		1A					14.5	52.5	108.0	172.0	232.0	299.0	365.0	417.0	430.0	455	
		2A					10.0	45.0	75.4	100.6	125.7	150.9	176.0	201.2	226.3	254	
		3A					9.0	30.1	45.1	60.2	75.2	90.3	105.3	120.4	135.4	152	
10	250	FC	8.4	214.2	3.1	80	45.9	189.3	329.3	461.8	583.3	689.9	778.5	847.7	897.9	950	
		1A					25.0	103.6	183.3	260.7	337.5	414.1	489.4	562.3	631.5	700	
		2A					17.0	78.8	118.2	157.6	197.0	236.4	275.8	315.2	354.6	398	
		3A					12.0	46.7	70.1	93.5	116.8	140.2	163.6	186.9	210.3	238	
12	300	FC	10.4	264.8	4.7	120	93.2	250.0	463.3	660.0	840.0	990.0	1115.0	1205.0	1250.0	1270	
		1A					66.7	167.8	276.8	382.9	485.5	586.9	692.1	796.9	893.0	970	
		2A					25.0	108.9	163.4	218.0	272.3	326.7	381.2	435.6	490.1	550	
		3A					17.0	67.3	101.0	134.6	168.3	202.0	235.6	269.3	302.9	340	
14	350	FC	12.4	315.5	5.5	140	127.4	407.5	673.4	915.6	1128.5	1316.5	1474.2	1593.1	1671.4	1740	
		1A					91.3	233.3	393.0	548.1	696.8	838.0	976.4	1105.4	1221.2	1300	
		2A					52.0	153.7	230.5	307.3	384.1	460.9	537.8	614.6	691.4	776	
		3A					27.0	91.9	137.8	183.7	229.7	275.6	321.6	367.5	413.4	464	
16	400	FC	14.1	357.7	6.3	160	189.0	497.0	891.8	1248.0	1535.4	1791.5	1950.0	2063.0	2161.6	2215	
		1A					101.3	276.5	448.1	615.0	779.1	941.9	1101.6	1255.7	1398.9	1530	
		2A					71.0	186.1	279.2	372.2	465.3	558.4	651.4	744.5	837.5	940	
		3A					47.0	112.5	168.7	224.9	281.2	337.4	393.6	449.9	506.1	568	

NOTE

C<sub>v</sub>: Valve flow coefficient

F<sub>L</sub>: Liquid pressure recovery factor

F<sub>C</sub>: Full Capacity                      1A: 1-Step reduction

2A: 2-Step reduction                      3A: 3-Step reduction

\* The bigger Cvs and sizes are available, please contact Metso.



### GB Series Cv vs travel Standard Trim (CAGE)

**ASME Class: 150# ~ 600#**

Size: 2" ~ 16"

Flow Characteristic: EQ-%

Valve Travel [%]							10	20	30	40	50	60	70	80	90	100	
FL							0.94	0.94	0.93	0.93	0.92	0.92	0.91	0.91	0.90	0.90	0.90
Valve Size		Orifice Dia.			Travel		Rated Cv										
Inch	mm	Sign	Inch	mm	Inch	mm											
2	50	FC	2.5	64.5	1.6	40	2.00	4.00	6.00	9.00	14.00	21.00	33.00	50.00	66.00	71	
		1A					1.07	3.28	5.45	7.57	9.75	12.79	17.86	26.28	39.68	50	
		2A					0.59	1.19	1.60	2.48	4.57	8.16	12.88	17.74	21.59	24	
		3A					0.34	0.70	0.94	1.45	2.67	4.76	7.51	10.35	12.59	14	
3	80	FC	3.5	89.0	2.0	50	4.00	8.50	14.50	22.00	33.50	51.00	75.00	108.00	128.00	138	
		1A					2.50	3.72	6.61	11.10	18.35	29.43	45.56	67.65	91.99	110	
		2A					1.22	2.48	3.34	5.17	9.52	17.00	26.82	36.97	44.98	50	
		3A					0.78	1.59	2.14	3.31	6.09	10.88	17.17	23.66	28.79	32	
4	100	FC	4.4	111.5	2.0	50	5.60	12.90	23.40	36.90	59.60	86.50	128.20	163.90	188.60	210	
		1A					2.75	6.68	11.68	17.92	28.59	46.21	71.85	105.81	141.21	160	
		2A					2.00	4.07	5.48	8.48	15.61	27.88	43.99	60.62	73.76	82	
		3A					1.22	2.48	3.34	5.17	9.52	17.00	26.82	36.97	44.98	50	
6	150	FC	5.3	133.6	2.4	60	6.50	15.00	27.70	47.10	77.10	123.80	198.50	265.20	316.00	340	
		1A					3.40	11.12	22.00	32.25	50.35	81.67	126.81	187.40	246.30	270	
		2A					3.32	6.76	9.08	14.06	25.89	46.24	72.95	100.54	122.34	136	
		3A					2.00	4.07	5.48	8.48	15.61	27.88	43.99	60.62	73.76	82	
8	200	FC	6.9	175.5	2.8	70	6.50	23.00	45.00	83.00	138.00	220.00	325.00	445.00	510.00	560	
		1A					5.60	19.00	39.00	58.00	94.00	148.00	222.00	310.00	405.00	450	
		2A					4.00	11.72	15.76	24.39	44.92	80.23	126.59	174.47	212.29	236	
		3A					3.00	7.05	9.48	14.68	27.03	48.27	76.17	104.98	127.73	142	
10	250	FC	8.4	214.2	3.1	80	8.10	33.20	65.70	124.40	216.80	350.10	493.20	619.90	747.60	830	
		1A					6.52	26.50	47.14	76.22	126.33	219.81	343.21	460.04	566.24	655	
		2A					6.13	18.58	24.97	38.66	71.19	127.15	200.62	276.49	336.42	374	
		3A					5.47	11.13	14.96	23.15	42.64	76.15	120.16	165.60	201.50	224	
12	300	FC	10.4	264.8	4.7	120	22.40	64.30	111.10	179.80	303.10	546.80	795.00	996.00	1155.00	1240	
		1A					15.54	44.65	73.67	110.47	174.20	277.57	441.34	650.51	837.52	960	
		2A					12.79	26.03	34.99	54.16	99.74	178.14	281.08	387.39	471.35	524	
		3A					7.67	15.60	20.97	32.45	59.77	106.75	168.43	232.14	282.45	314	
14	350	FC	12.4	315.5	5.5	140	24.70	82.30	158.30	266.70	427.00	693.90	1015.80	1277.20	1514.70	1650	
		1A					18.94	60.21	103.15	164.81	260.61	405.54	630.90	903.93	1141.45	1275	
		2A					16.21	37.06	49.81	77.10	142.00	253.61	400.17	551.51	671.05	746	
		3A					10.89	22.16	29.78	46.10	84.89	151.62	239.24	329.72	401.19	446	
16	400	FC	14.1	357.7	6.3	160	35.10	100.40	167.00	268.40	471.00	849.30	1265.10	1603.90	1911.60	2090	
		1A					26.32	73.03	119.55	175.70	286.98	477.71	773.09	1125.40	1432.44	1680	
		2A					20.85	42.42	57.03	88.27	162.55	290.33	458.10	631.35	768.20	854	
		3A					12.50	25.43	34.19	52.92	97.46	174.06	274.65	378.52	460.56	512	

**NOTE**

C<sub>v</sub>: Valve flow coefficient

F<sub>L</sub>: Liquid pressure recovery factor

F<sub>C</sub>: Full Capacity                      1A: 1-Step reduction

2A: 2-Step reduction                      3A: 3-Step reduction

\* The bigger Cvs and sizes are available, please contact Metso.

### GB Series CV vs travel Standard Trim (Tendril 1)

**ASME Class: 150# ~ 600#**

Size: 2" ~ 16"

Flow Characteristic: LINEAR

Valve Travel [%]							10	20	30	40	50	60	70	80	90	100		
FL							0.84	0.84	0.85	0.85	0.85	0.86	0.87	0.87	0.95	0.86		
Valve Size		Orifice Dia.			Travel		Rated Cv											
Inch	mm	Sign	Inch	mm	Inch	mm												
2	50	FT	2.5	64.5	1.6	40	3.0	11.8	19.7	26.6	33.2	39.0	43.8	47.7	50.8	52		
		1T					1.9	7.7	13.0	17.7	22.4	26.8	31.0	34.8	38.3	40		
		2T					1.2	4.8	8.1	11.2	14.3	17.2	20.1	22.8	25.4	27		
		3T					0.4	1.7	2.9	4.0	5.2	6.3	7.4	8.5	9.6	10		
3	80	FT	3.5	89.0	2.0	50	7.5	23.0	36.9	49.9	61.9	73.2	82.9	91.2	98.0	102		
		1T					4.7	14.6	23.7	32.4	40.6	48.8	56.4	63.6	70.4	75		
		2T					2.4	7.6	12.4	17.1	21.7	26.2	30.5	34.8	38.9	40		
		3T					1.2	3.9	6.4	8.9	11.3	13.8	16.1	18.4	20.7	21		
4	100	FT	4.4	111.5	2.0	50	8.5	32.6	55.1	75.9	95.6	113.8	130.5	144.6	156.2	160		
		1T					5.3	20.4	34.8	48.3	61.5	74.1	86.7	98.5	109.6	120		
		2T					2.9	11.3	19.5	27.3	34.9	42.4	49.9	57.1	64.2	70		
		3T					1.9	7.6	13.2	18.5	23.8	28.9	34.2	39.2	44.1	46		
6	150	FT	5.3	133.6	2.4	60	13.8	54.4	95.1	134.3	170.9	204.3	234.1	259.9	281.9	290		
		1T					9.0	35.2	61.8	88.2	114.1	139.2	163.1	185.7	206.9	220		
		2T					4.9	18.9	33.1	47.3	61.6	75.9	90.1	104.1	117.9	130		
		3T					2.9	10.8	18.8	26.9	35.0	43.2	51.4	59.5	67.7	75		
8	200	FT	6.9	175.5	2.8	70	19.7	87.1	152.3	213.7	271.5	323.2	368.8	409.4	444.2	460		
		1T					12.7	56.0	98.8	140.5	181.6	220.5	257.3	292.4	324.9	340		
		2T					6.4	28.0	49.5	70.8	92.4	113.6	134.4	155.2	175.5	195		
		3T					3.6	15.6	27.5	39.3	51.4	63.3	75.1	87.1	99.0	105		
10	250	FT	8.4	214.2	3.1	80	39.7	122.6	206.9	287.7	361.2	430.8	493.5	548.0	597.7	630		
		1T					25.7	78.3	132.7	186.4	237.5	288.4	337.1	382.2	426.0	460		
		2T					14.2	41.5	69.9	98.4	126.0	154.4	182.4	209.4	236.8	255		
		3T					8.4	23.2	38.6	54.1	69.1	84.6	100.2	115.3	130.8	140		
12	300	FT	10.4	264.8	4.7	120	76.8	216.1	351.6	478.6	594.1	696.7	786.2	863.1	928.4	980		
		1T					48.9	136.8	224.6	310.8	394.0	473.3	548.1	617.8	682.3	735		
		2T					25.2	68.8	112.8	156.8	200.8	244.4	287.5	330.0	371.7	405		
		3T					15.4	40.7	66.1	91.7	117.4	143.1	168.8	194.5	220.0	240		
14	350	FT	12.4	315.5	5.5	140	89.2	275.6	460.6	634.1	789.1	929.1	1050.3	1151.4	1237.4	1300		
		1T					56.5	174.0	293.5	410.7	521.9	629.9	731.6	824.7	912.3	985		
		2T					29.7	90.1	152.1	214.2	274.8	336.1	396.5	454.9	513.1	565		
		3T					16.4	48.4	81.3	114.3	146.8	179.9	212.9	245.3	278.2	310		
16	400	FT	14.1	357.7	6.3	160	121.6	332.6	546.9	756.9	949.0	1121.7	1274.6	1402.5	1508.5	1580		
		1T					73.6	198.0	326.6	458.4	586.9	712.2	834.3	948.3	1055.2	1145		
		2T					41.5	108.3	177.2	248.6	319.8	391.4	464.1	535.3	605.7	670		
		3T					26.9	68.0	110.1	153.6	197.1	241.1	286.2	330.8	375.6	415		

**NOTE**

- C<sub>v</sub>: Valve flow coefficient
- F<sub>L</sub>: Liquid pressure recovery factor
- F<sub>C</sub>: Full Capacity            1A: 1-Step reduction
- 2A: 2-Step reduction        3A: 3-Step reduction

\* The larger Cvs and sizes are available, please contact Metso.

**GB, Valve dimensions and weights**

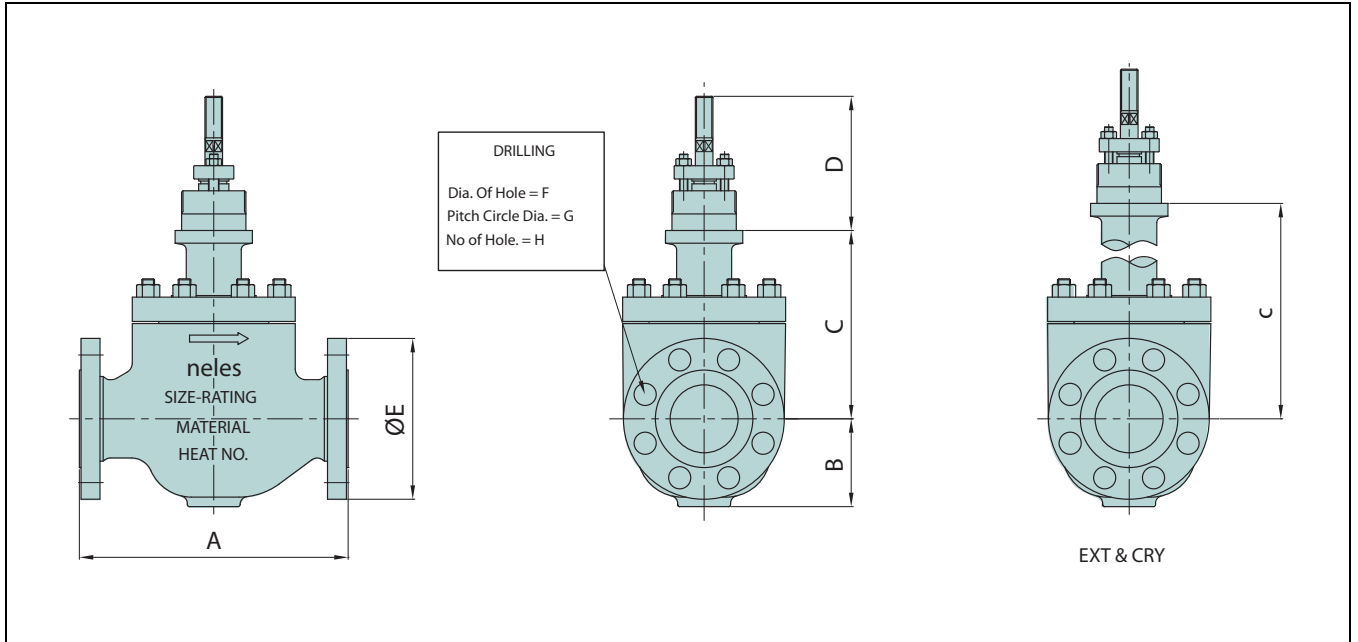

**150 # / 300 # / 600 #**

Dimension (mm)	A			B			C			D	E			F			G			H			Weight (kg) (Approximate)		
	150#	300#	600#	150#	300#	600#	STD	EXT	CRY	COMMON	150#	300#	600#	150#	300#	600#	150#	300#	600#	150#	300#	600#	150#	300#	600#
50	254	267	286	83	83	83	178	333	458	110	150	165	165	19.1	19.1	19.1	120.7	127	127	4	8	8	30	32	40
80	298	318	337	109	109	120	222	395	545	115	190	210	210	19.1	22.2	22.2	152.4	168.3	168.3	4	8	8	65	67	72
100	352	368	394	135	135	135	248	402	552	140	230	255	275	19.1	22.2	25.4	190.5	200	215.9	8	8	8	100	103	112
150	451	473	508	170	170	178	340	467	642	150	280	320	355	22.2	22.2	28.6	241.3	269.9	292.1	8	12	12	185	195	240
200	543	568	610	230	230	230	451	557	732	150	345	380	420	22.2	25.4	31.8	298.5	330.2	349.2	8	12	12	363	385	443
250	673	708	752	275	275	275	488	670	870	150	405	445	510	25.4	28.6	34.9	362	387.4	431.8	12	16	16	552	595	681
300	737	775	819	350	350	350	543	716	916	140	485	520	560	25.4	31.8	34.9	431.8	450.8	489	12	16	20	905	955	1020
350	889	927	972	385	385	385	616	846	1046	210	535	585	605	28.6	31.8	38.1	476.3	514.4	527	12	20	20	1170	1230	1311
400	1016	1057	1108	440	440	440	692	909	1109	220	595	650	685	28.6	34.9	41.3	539.8	571.5	603.2	16	20	20	1380	1460	1587

Dimension (inch)	A			B			C			D	E			F			G			H			Weight (kg) (Approximate)		
	150#	300#	600#	150#	300#	600#	STD	EXT	CRY	COMMON	150#	300#	600#	150#	300#	600#	150#	300#	600#	150#	300#	600#	150#	300#	600#
2"	10	10.5	11.3	3.3	3.3	3.3	7	13.1	18	4.3	5.9	6.5	6.5	0.75	0.75	0.75	4.8	5	5	4	8	8	66	71	88
3"	11.7	12.5	13.3	4.3	4.3	4.7	8.7	15.6	21.5	4.5	7.5	8.3	8.3	0.75	0.87	0.87	6	6.6	6.6	4	8	8	143	148	159
4"	13.9	14.5	15.5	5.3	5.3	5.3	9.8	15.8	21.7	5.5	9.1	10	10.8	0.75	0.87	1	7.5	7.9	8.5	8	8	8	220	227	247
6"	17.8	18.6	20	6.7	6.7	7	13.4	18.4	25.8	5.9	11	12.6	14	0.87	0.87	1.13	9.5	10.6	11.5	8	12	12	408	430	529
8"	21.4	22.4	24	9.1	9.1	9	17.8	21.9	28.8	5.9	13.6	15	16.5	0.87	1	1.25	11.8	13	13.8	8	12	12	800	849	977
10"	26.5	27.9	29.6	10.8	10.8	10.8	19.2	26.4	34.3	5.9	15.9	17.5	20.1	1	1.13	1.37	14.3	15.3	17	12	16	16	1217	1312	1501
12"	29	30.5	32.2	13.8	13.8	13.8	21.4	28.2	36.1	5.9	19.1	20.5	22.1	1	1.25	1.37	17	17.8	19.3	12	16	20	1995	2105	2249
14"	35	36.5	38.2	15.2	15.2	15.2	24.3	33.3	41.2	8.3	21.1	23	23.8	1.13	1.25	1.5	18.8	20.3	20.8	12	20	20	2579	2712	2890
16"	40	41.6	43.6	17.3	17.3	17.3	27.2	35.8	43.7	8.7	23.4	25.6	27	1.13	1.37	1.63	21.3	22.5	23.8	16	20	20	3042	3219	3499

900 #/ 1500#

Dimension (mm)	A		B		C		D	E		F		G		H		Weight (kg) (Approximate)	
	900#	1500#	900#	1500#	STD	EXT	COMMON	900#	1500#	900#	1500#	900#	1500#	900#	1500#	900#	1500#
040	333	333	100	100	240	380	110	180	180	28.5	28.5	123.8	123.8	4	4	63	63
050	375	375	113	113	240	380	110	215	215	25.4	25.4	165.1	165.1	8	8	67	67
080	441	460	142	142	322	430	115	240	265	25.4	31.7	190.5	203.2	8	8	150	163
100	511	530	182	182	376	475	140	290	310	31.8	34.9	235	241.3	8	8	244	255
150	714	768	210	240	420	500	150	380	395	31.8	39	317.5	317.5	12	12	530	540
200	914	972	290	290	550	600	150	470	485	38.1	45	393.7	393.7	12	12	698	821
250	991	1067	310	350	600	700	150	545	585	38.1	51	469.9	482.6	16	12	955	1137
300	1130	1219	385	385	680	800	140	610	675	38.1	54	533.4	571.5	20	16	1180	1240
350	1257	1257	385	385	770	920	210	640	750	41.3	61	558.8	635	20	16	1387	1477
400	1422	1422	450	450	850	1050	220	705	825	44.5	67	616	704.8	20	16	1601	1721

Dimension (inch)	A		B		C		D	E		F		G		H		Weight (lbs) (Approximate)	
	900#	1500#	900#	1500#	STD	EXT	COMMON	900#	1500#	900#	1500#	900#	1500#	900#	1500#	900#	1500#
1-1/2"	13.1	13.1	3.9	3.9	9.5	15	4.3	7.1	7.1	1.13	1.13	4.9	4.9	4	4	139	139
2"	14.8	14.8	4.5	4.5	9.5	15	4.3	8.5	8.5	1	1	6.5	6.5	8	8	148	148
3"	17.4	18.1	5.6	5.6	12.7	16.9	4.5	9.5	10.4	1	1.25	7.5	8	8	8	331	359
4"	20.1	20.9	7.2	7.2	14.8	18.7	5.5	11.4	12.2	1.25	1.37	9.3	9.5	8	8	538	562
6"	28.1	30.2	8.3	9.5	16.5	19.7	5.9	15	15.6	1.25	1.54	12.5	12.5	12	12	1168	1190
8"	36	38.3	11.4	11.4	21.7	23.6	5.9	18.5	19.1	1.5	1.77	15.5	15.5	12	12	1539	1810
10"	39	42	12.2	13.8	23.6	27.6	5.9	21.5	23	1.5	2.01	18.5	19	16	12	2105	2507
12"	44.5	48	15.2	15.2	26.8	31.5	5.9	24	26.6	1.5	2.13	21	22.5	20	16	2601	2734
14"	49.5	49.5	15.2	15.2	30.3	36.2	8.3	25.2	29.5	1.63	2.4	22	25	20	16	3058	3256
16"	56	56	17.7	17.7	33.5	41.3	8.3	27.8	32.5	1.75	2.64	24.3	27.8	20	16	3530	3794

\* Bigger sizes and ASME class 2500 ratings are available, please contact Metso.

## HOW TO ORDER

### Globe balanced, Cage guided type, Series GB

1.	2.	3.	4.	5.	6.	7.	8.	9.	10.	11.	12.	13.	14.	15.	16.	17.	18.	19.	20.	21.	22.
GB	03	C	W	A	J2	B	P1	X	BC	S1	R1	X	S	G	G	S	A	X	A	L	FC

#### VALVE CONSTRUCTIONS

1.	<b>VALVE SERIES</b>	
GB	Globe Balanced, Cage guided type	

2.	<b>BODY SIZE</b>			
02	2" / DN 50	03	3" / DN 80	
04	4" / DN 100	06	6" / DN 150	
08	8" / DN 200	10	10" / DN 250	
12	12" / DN 300	14	14" / DN 350	
16	16" / DN 400			
<b>Optional body size</b>				
18	18" / DN 450	20	20" / DN 500	
24	24" / DN 600	YY	Special	

3.	<b>PRESSURE RATING</b>			
C	ASME class 150	D	ASME class 300	
F	ASME class 600	K	EN PN 16	
M	EN PN 40			
<b>Optional Pressure Rating</b>				
G	ASME class 900	H	ASME class 1500	
I	ASME class 2500	N	EN PN 63	
P	EN PN 100	B	EN PN 160	
E	EN PN 250	Y	Special	

- K: available for DN50-DN150

- M: available for DN50-DN150

4.	<b>END CONNECTION</b>	
W	Flanged RF, ASME B16.5	
C	Flanged RF, EN 1092-1	
V	Socket welding, ASME B16.11	
Q	Butt welding, ASME B16.25	
<b>Optional end connection</b>		
Z	Ring joint flange, ASME B16.5	
Y	Special	

5.	<b>BONNET CONSTRUCTION</b>	
	<b>Bonnet type</b>	<b>Actuator connection</b>
A	General	Applicable for VD_25/29/37
B	General	Applicable for VD_48/55
C	General	Applicable for VC_30, VB_32
D	General	Applicable for VC/VB_40/50/60/70
E	Extension	Applicable for VD_25/29/37
F	Extension	Applicable for VD_48/55
G	Extension	Applicable for VC_30, VB_32
H	Extension	Applicable for VC/VB_40/50/60/70
P	Cryogenic	Applicable for VD_25/29/37
Q	Cryogenic	Applicable for VD_48/55
R	Cryogenic	Applicable for VC_30, VB_32
S	Cryogenic	Applicable for VC/VB_40/50/60/70
Y	Special	Special

6.	<b>BODY MATERIAL</b>			
J2	A216 gr. WCB	S6	A351 gr. CF8M	
<b>Optional Body &amp; Bonnet Material</b>				
S1	A351 gr. CF3M	YY	Special	

- Bonnet material is equivalent to Body material.

7.	<b>MODEL CODE</b>	
B	Model B	

#### TRIM CONSTRUCTIONS

8.	<b>PLUG MATERIAL</b>	
	<b>Material</b>	<b>Description</b>
P1	CA15	General for carbon steel valve
T6	CF8M	General for stainless steel valve
<b>Optional plug material</b>		
S1	CF3M	
YY	Special	Special materials

9.	<b>PLUG APPLICATION</b>	
X	Not applicable	
A	Cobalt based alloy	
Y	Special	

10.	<b>STEM MATERIAL</b>	
	<b>Material</b>	<b>Description</b>
BC	630 SS + HCr	General for carbon steel valve
TC	316 SS + HCr	General for stainless steel valve
<b>Optional stem material</b>		
FC	316L SS + HCr	
YY	Special	Special materials

11.	<b>SEAT TYPE</b>	
S1	Single metal seat	
T1	Single soft seat	
YY	Special	

12.	<b>SEAT / CAGE MATERIAL</b>		
	<b>Seat</b>	<b>Cage</b>	<b>Cage Guide</b>
R1	CA15	CB7Cu-1 / 630 SS + HCr	CB7Cu-1 + HCr
R6	CF8M	CF8M / 316 SS + HCr	CF8M + HCr
<b>Optional seat / Cage material</b>			
R3	CF3M	CF3M / 316L SS + HCr	CF3M + HCr
YY	Special	Special	Special

- CA15 / AISI 410 is general for carbon steel valve.  
- CF8M / AISI 316 is general for stainless steel valve..

13.	<b>SEAT APPLICATION</b>	
X	Not applicable	
A	Cobalt based alloy	
P	Insert PTFE	
<b>Optional seat application</b>		
Q	Insert PTFE + Cobalt based alloy	
Y	Special	

**OTHERS**

14. PACKING / BELLOWS TYPE	
S	General packing
E	Low Emission, Live Loaded
Optional packing / Bellows type	
C	Bellows Seal (316L SS, Formed)
Y	Special

15. PACKING MATERIAL	
G	PTFE + Carbon fiber
F	Graphite
T	PTFE V-Ring
Optional packing material	
H	Hi-Graphite
Y	Special

16. SEAL RING MATERIAL	
G	PTFE + Graphite
T	PTFE
H	PTFE + Graphite + Carbon
Y	Special

17. GASKET MATERIAL	
S	S/W gasket type, 316 SS + Graphite for general
L	S/W gasket type, 316 SS + PTFE
Optional gasket material	
H	S/W gasket type, 316 SS + Graphite for high temp.
Y	Special

18. STUD / NUT MATERIAL	
A	A193 gr. B7 / A194 gr. 2H
B	A193 gr. B8 / A194 gr. 8
K	A320 gr. B8M cl. 2 / A194 gr. 8M
Optional stud / Nut material	
H	A193 gr. B16 / A194 gr. 4
Y	Special

19. OPTIONS	
X	Not applicable
E	Anti-erosion
Special options	
L	Lub. & Isol. valve
W	Water seal
Y	Special

\* ASME valve face to face length according to ISA 75.08. EN valve face to face length according to ISA 75.08.  
 \* The body, bonnet, trim materials are subject to change as equivalent depending on detail design.  
 \* See 'NelesGlobe Type code Instruction' for further options and explanations.

**TRIM TYPE & RATED Cv**

20. Sign	TRIM TYPE	21. Sign	TRIM CHARACTERISTIC	22. Sign	Description	RATED Cv																							
						Body Size and Stroke																							
						2"	Str.	3"	Str.	4"	Str.	6"	Str.	8"	Str.	10"	Str.	12"	Str.	14"	Str.	16"	Str.						
A P	General plug Pilot balanced plug	L	Linear	FC	General / Full capacity	74	(40)	142	(50)	230	(50)	380	(60)	600	(70)	950	(80)	1270	(120)	1740	(140)	2215	(160)						
				1A	General / 1-Step reduction	48	(40)	98	(50)	160	(50)	275	(60)	455	(70)	700	(80)	970	(120)	1300	(140)	1530	(160)						
2A	General / 2-Step reduction			26	(40)	56	(50)	86	(50)	150	(60)	254	(70)	398	(80)	550	(120)	776	(140)	940	(160)								
3A	General / 3-Step reduction			16	(40)	34	(50)	52	(50)	90	(60)	152	(70)	238	(80)	340	(120)	464	(140)	568	(160)								
FT	Tendril 1 / Full capacity			52	(40)	102	(50)	160	(50)	290	(60)	460	(70)	630	(80)	980	(120)	1300	(140)	1580	(160)								
1T	Tendril 1 / 1-Step reduction			40	(40)	75	(50)	120	(50)	220	(60)	340	(70)	460	(80)	735	(120)	985	(140)	1145	(160)								
2T	Tendril 1 / 2-Step reduction			27	(40)	40	(50)	70	(50)	130	(60)	195	(70)	255	(80)	405	(120)	565	(140)	670	(160)								
3T	Tendril 1 / 3-Step reduction			10	(40)	21	(50)	46	(50)	75	(60)	105	(70)	140	(80)	240	(120)	310	(140)	415	(160)								
FM	Tendril 2 / Full capacity			50	(40)	100	(50)	155	(50)	280	(60)	425	(70)	590	(80)	920	(120)	1240	(140)	1530	(160)								
1M	Tendril 2 / 1-Step reduction			35	(40)	74	(50)	115	(50)	215	(60)	330	(70)	450	(80)	720	(120)	970	(140)	1130	(160)								
2M	Tendril 2 / 2-Step reduction			23	(40)	33	(50)	65	(50)	120	(60)	190	(70)	240	(80)	380	(120)	550	(140)	640	(160)								
3M	Tendril 2 / 3-Step reduction			8	(40)	18	(50)	38	(50)	67	(60)	100	(70)	130	(80)	220	(120)	290	(140)	390	(160)								
				E	Equal %	FC	General / Full capacity	71	(40)	138	(50)	210	(50)	340	(60)	560	(70)	830	(80)	1240	(120)	1650	(140)	2090	(160)				
						1A	General / 1-Step reduction	50	(40)	110	(50)	160	(50)	270	(60)	450	(70)	655	(80)	960	(120)	1275	(140)	1680	(160)				
		2A	General / 2-Step reduction			24	(40)	50	(50)	82	(50)	136	(60)	236	(70)	374	(80)	524	(120)	746	(140)	854	(160)						
		3A	General / 3-Step reduction			14	(40)	32	(50)	50	(50)	82	(60)	142	(70)	224	(80)	314	(120)	446	(140)	512	(160)						
		FT	Tendril 1 / Full capacity			50	(40)	82	(50)	135	(50)	235	(60)	370	(70)	500	(80)	840	(120)	1110	(140)	1400	(160)						
		1T	Tendril 1 / 1-Step reduction			35	(40)	58	(50)	95	(50)	170	(60)	265	(70)	370	(80)	600	(120)	785	(140)	1020	(160)						
		2T	Tendril 1 / 2-Step reduction			20	(40)	35	(50)	58	(50)	100	(60)	170	(70)	225	(80)	355	(120)	480	(140)	600	(160)						
		3T	Tendril 1 / 3-Step reduction			10	(40)	20	(50)	32	(50)	58	(60)	105	(70)	125	(80)	205	(120)	290	(140)	350	(160)						
		FM	Tendril 2 / Full capacity			47	(40)	74	(50)	130	(50)	230	(60)	330	(70)	470	(80)	770	(120)	1050	(140)	1320	(160)						
		1M	Tendril 2 / 1-Step reduction			33	(40)	56	(50)	92	(50)	165	(60)	245	(70)	330	(80)	570	(120)	720	(140)	960	(160)						
		2M	Tendril 2 / 2-Step reduction			19	(40)	33	(50)	52	(50)	95	(60)	145	(70)	190	(80)	330	(120)	430	(140)	550	(160)						
		3M	Tendril 2 / 3-Step reduction			8	(40)	16	(50)	25	(50)	52	(60)	80	(70)	110	(80)	190	(120)	270	(140)	295	(160)						
		Y	Special			Y	Special	YY	Special	Contact Metso for Cv details																			

- Rated Cv is different depending on trim characteristic.

- Str. : valve stroke length(mm). It should be matched with actuator stroke length.

**Metso Corporation**

Töölönlahdenkatu 2, PO Box 1220, 00100 Helsinki, Finland

Tel. +358 20 484 100

<http://contact.metso.com/>

**Metso Flow Control Inc.**

Vanha Porvoontie 229, P.O. Box 304, FI-01301 Vantaa, Finland.

Tel. +358 20 483 150. Fax +358 20 483 151

[www.metso.com/valves](http://www.metso.com/valves)

Subject to change without prior notice. Product names in this bulletin are all trademarks of Metso Flow Control Inc.

