

Series A angle pattern control valves

AU: Angle pattern-Unbalanced top guided

AB: Angle pattern-Balanced cage guided

AM: Angle pattern-Omega multi-path & multi-stage

Metso's Neles A series angle pattern globe valves are economical high-performance control valves designed to provide the best possible control accuracy and wide rangeability with the all inherent benefits of linear control valves. The A series valves are designed for use in modulating control, available with Unbalanced trim, Balanced cage trim and Omega multistage trim. They provide reliable operation and are well suited for many different kind of applications.

The angle pattern valves are especially suitable for severe applications where high pressure drop and erosive fluid exist. The flow in an angle valve does not impact directly into the body as it exits the trim, instead, it passes straight down into the downstream piping, which is an advantage if the fluid is erosive and moving at high velocity. Standard valves are equipped with spring diaphragm actuators and NDX® intelligent valve controllers for precise flow control, extended operational life and performance monitoring on-line.

Construction

- Compact and lightweight construction
- Wide variety of trims with different Cv and characteristics
- Both metal and soft seat available depending from the application
- Option for bellows seal for toxic or other application where no leak is allowed
- Wide material selection for different applications
- Many end connection styles available for different applications
- Extension bonnet design for wide temperature range

Wide range of applications

- Suitable for gas, liquid and steam
- Temperature limits -29...+260 °C with standard bonnet construction. Over +260 °C and under -29 °C with extension bonnet
- Tendril multi-hole trim for high pressure drop and cavitation applications
- Micro trim for small flow and/or to get rid of the stability problems in high pressure drop application
- Omega multistage trim for severe service applications



Accurate control

- ND9000 digital valve controller for auto-calibration and accurate control
- Accurate and sensitive diaphragm and piston actuators

Safety and quality

- Rugged one piece body structure to minimize the leak paths and makes the valve insensitive to pipe stress
- Strictly tested to ensure specified performance with quality assurance systems in according to ISO 9001
- Certified ISO 15848 fugitive emissions
- Certified CE/PED & ATEX, TSG & EAC (GOST-R)

Easy maintenance

- Quick change trim and top entry construction for easy in-line maintenance
- Valve assembly is easy and self guiding
- Flow characteristics can be easily changed with interchangeable trim parts
- ND9000 and NDX digital valve controller with online diagnostics enables performance follow up and predictive maintenance
- Efficient asset management with Metso FieldCare open architecture software and excellent networking capabilities

AU, Different trim designs

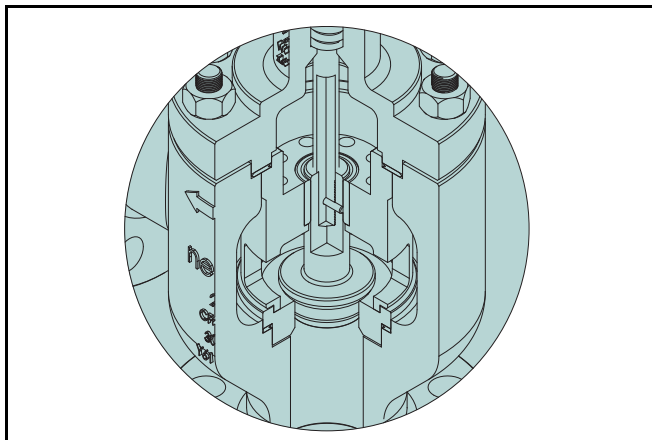

AU, Standard contoured trim

AU, Quick change standard contoured plug offers a smooth flow profile. The trim is most suited to low pressure drop application and is used in the majority of control applications.

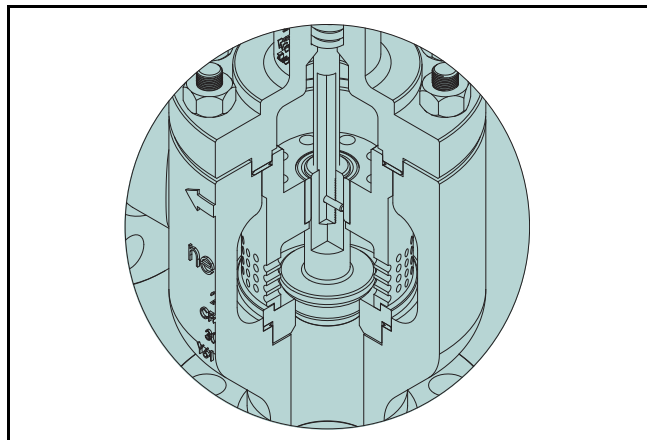

AU, Tendril trim

AU, Tendril trim is multi drilled hole trim. This gives excellent resistance to noise on high pressure drop applications.

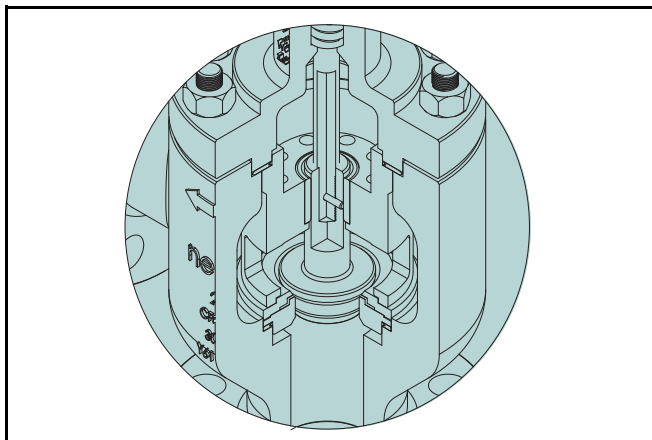

AU, Soft seat trim

AU, Soft seat option is used on applications where bubble tight shut off, seat leakage class VI is required.

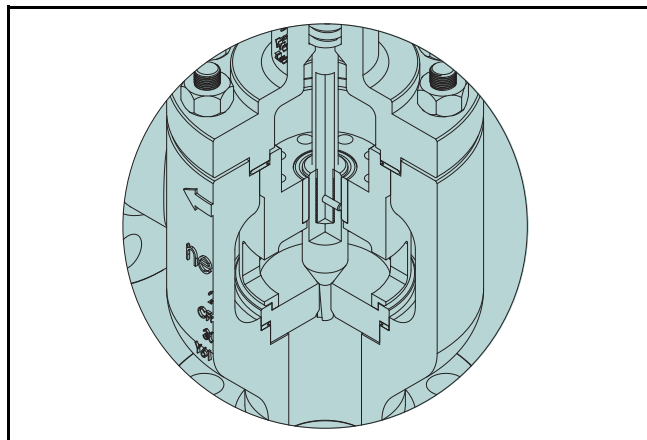

AU, Micro trim

AU, Micro trim design is an ideal selection for the very low flow rates which is from rated Cv 0.003 to 0.1.

AB, Different trim designs

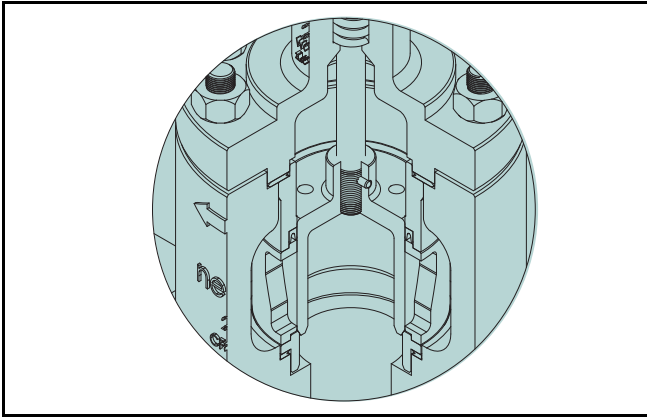

AB, Quick change, standard cage trim

The standard cage trim is designed with a specially represented window shape cage and balanced plug. The window shape defines the flow path and the flow characteristic of the valve (linear, equal percentage, others).. The balancing holes are located in the top of the plug. This trim is suited for both high and low pressure drop application and is used in the majority of control applications.

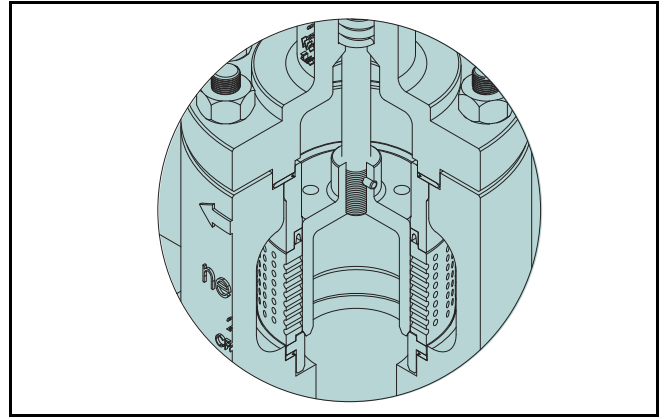

AB, Tendril Multi-hole trim

The trim design presented a multi-hole trim. There are Tendril 1 or Tendril 2 designs in standard depending on pressure drop and potential for cavitation.

The pressure drop is divided by multi-hole so that the pressure progressively reduces as it passes through the trim. This gives excellent resistance to cavitation on high pressure drop applications.

AM, Different trim designs

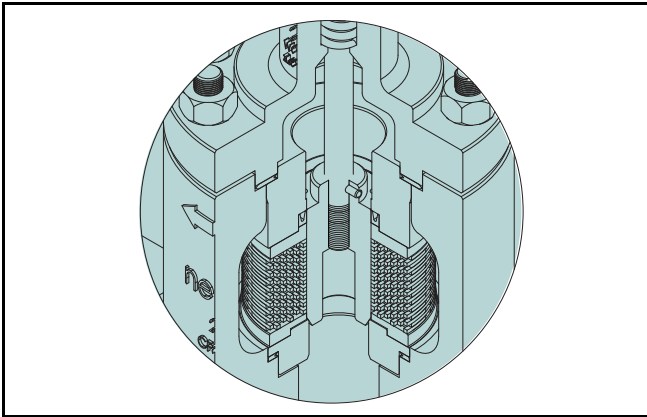

AM, Omega quick change, Standard balanced trim

The Omega standard balanced trim design is based on 2 or 3 dimensional labyrinth disk stack cage and balanced plug. The opened disk stack shape defines the flow path and flow characteristics of the valve (linear, equal percentage, others) standard trim characteristic is linear.

The balancing holes are located in the top of the plug. This trim is specially suited to high pressure drop application and is used in the majority of control applications.

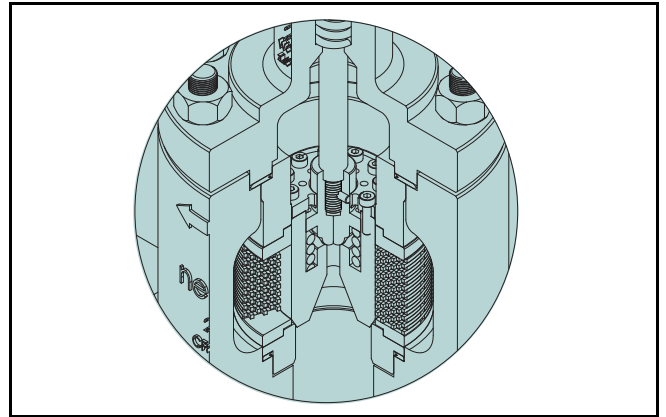

AM, Omega quick change, Pilot balanced trim

Pilot balanced trim construction is designed with a special pilot plug & seat built-in the main plug.

The design gives excellent seat tightness to leakage on high pressure drop and high temperature applications. The design applicable TSO (Tight Shut Off, seat leakage class V) requirement in high temperature services.

APPLICATION GUIDE

AU, Temperature range & seat leakage class with different bonnet & seat applications

Valve Size Inch	ASME Rating	Seat Type	Temperature Range (°C)		Seat Leakage class (ANSI B 16,104)	
			Standard Bonnet	Extension Bonnet	Standard	Optional
Up to 4	150 ~ 1500	Metal	-29 ~ +260	-196 ~ +593	IV	V
	150 ~ 600	Soft	-29 ~ +232	-196 ~ +232	VI	

AB/AM, Temperature range

PTFE + Graphite pressure energized seal with metal seat: -40...+260 °C
 PTFE + Graphite + Carbon pressure energized seal with metal seat: -29...+320°C
 PTFE pressure energized seal with metal seat: -196...+232 °C
 Metal seat: -196...+593 °C

Shut-off classification

Class IV with soft seal & metal seat per ANSI FCI 70-2. (0.01 % of valve rated capacity).
 Class V with soft seat or pilot balanced plug per ANSI FCI 70-2.

AU/AB/AM, Temperature range with different body and stud/nut materials

Body, Bonnet Material	Stud , Nut Material	Temp. Range (°C)	Sign
Carbon steel (WCB, A105)	ASTM A193-B7 STUD ASTM A194-2H NUT	-29 ~ +425	A
Stainless steel (CF3, CF8, CF3M, CF8M)	ASTM A193-B7 STUD ASTM A194-2H NUT	-46 ~ +538	A
	ASTM A193-B8 STUD ASTM A194-8 NUT	-196 ~ +538	B
Cr.Mo. Steel (WC6, F11, WC9, F22, C12A, F91)	ASTM A193-B16 STUD ASTM A194-4 NUT	-29 ~ +593	H

*Please contact Metso.

AU/AB/AM, Trim materials

AU/AB/AM, Trim				Temperature Range (°C)	Sign
Plug	Stem	Seat	Retainer/ Cage/Disk		
410 SS	630 SS + HCr	410 SS	630 SS	-29 ~ +425	P1XBCS1R1X
316 SS	316 SS + HCr	316 SS	316 SS	-196 ~ +425	T6XTCS1T6X
316 SS + Cobalt based	316 SS + HCr	316 SS + Cobalt based	316 SS	-196 ~ +425	T6ATCS1T6A
420 J2	630 SS + HCr	420 J2	420 J2	-10 ~ +540	P2XBCS1P2X
316 SS + HCr	316 SS + HCr	316 SS	316L SS	-196 ~ +425	T6XTCS1R4X
316 SS	316 SS + HCr	316 SS + HCr	316 SS	-196 ~ +232	*
6300 SS	630 SS + HCr	410 SS	410 SS	-29 ~ +425	*
Inconel 625, 718, 750				-196 ~ +645	*

*Please contact Metso.

*Disk (AM) : Standard materials are 420J2 & Inconel 718, please contact Metso for other applications.

AU/AB/AM, Gasket applications

Body, Bonnet Material	Gasket Material	Temp. Range (°C)	Sign
Carbon steel (WCB, A105)	S/W (Spiral Wound) 316SS + Graphite	-29 ~ +425	G
Stainless steel (CF8, CF8M, CF3, CF3M)	S/W (Spiral Wound) 316SS + Graphite	-196 ~ +425	T
	S/W (Spiral Wound) 316SS + PTFE	-196 ~ +232	F
Cr.Mo. Steel (WC6, WC9, F22, C12A, F91)	S/W (Spiral Wound) 316SS + Graphite + Non Asbestos	-29 ~ +593	H

*Please contact Metso.

AU/AB/AM, Packing applications

Packing Material	Temp (°C)	Pr. Class
PTFE + Carbon Fiber (Braided TEF + Graphite), standard	-196 ~ +260	Up to CL900
PTFE V-Ring	-49 ~ +232	Up to CL600
Graphite (with Mold + Braided)	-196 ~ +400	Up to CI2500
Hi-Graphite (with Mold + Braided)	-49 ~ +593	Up to CI2500
RTFE V-Ring + Metal	- 40 ~ +350	Up to CI600

*Please contact Metso.

Flow direction

Retainer Series	Plug		Cage Series	General plug					Pilot balanced plug		
	General	Tendrill 1		General	Tendrill 1 (Gas)	Tendrill 1 (Liquid)	Tendrill 2 (Gas)	Tendrill 2 (Liquid)	General	Tendrill 1	Tendrill 2
AU	FTO or FTC	FTO or FTC	AB	FTC	FTO	FTC	FTO	FTC	FTC	FTC	FTC

Disk stack Series	Plug		Pilot balanced plug	Unbalanced plug
	General (Gas)	General (Liquid)	General	General
AM	FTO	FTC	FTC	FTO

* FTO: Flow to open
 FTC: Flow to close

Cv ratio

AU & AB 50: 1
AM 100: 1

Flow characteristics

AU : Equal percentage, linear
AB : Equal percentage, linear
AM : Equal percentage, linear and customized %

Packing constructions

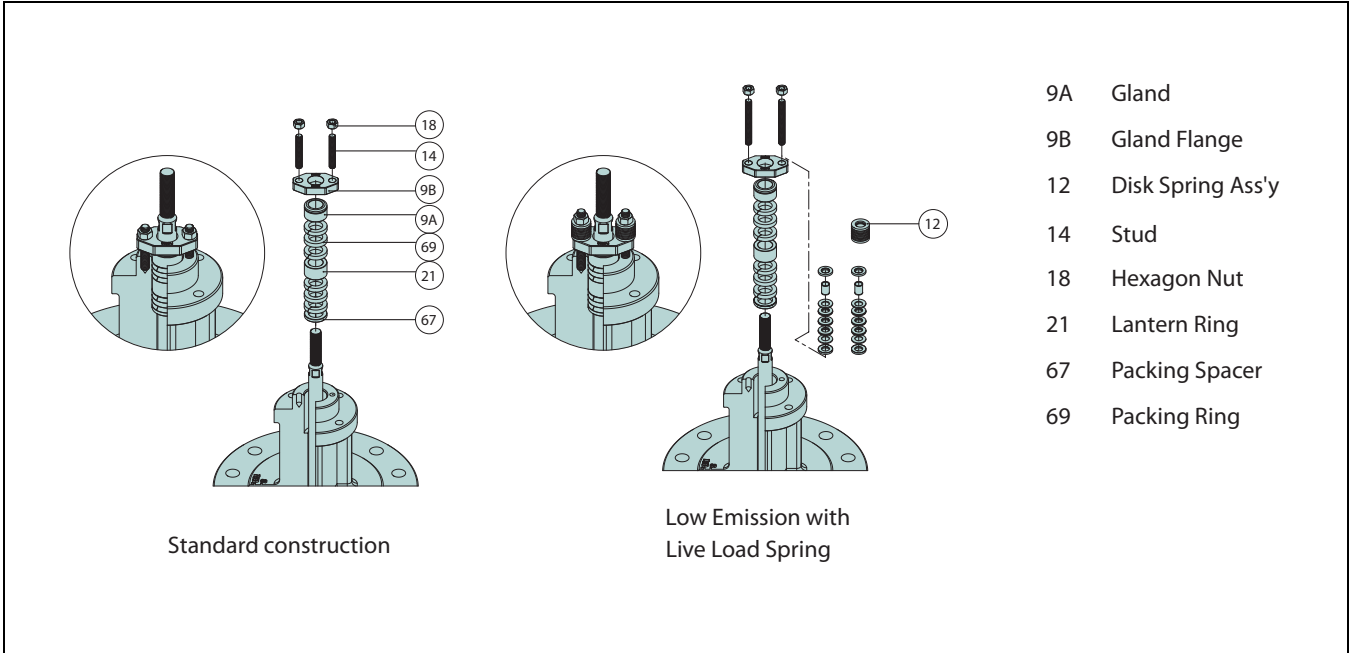

Seal-ring & seat solutions for AB & AM valve trims

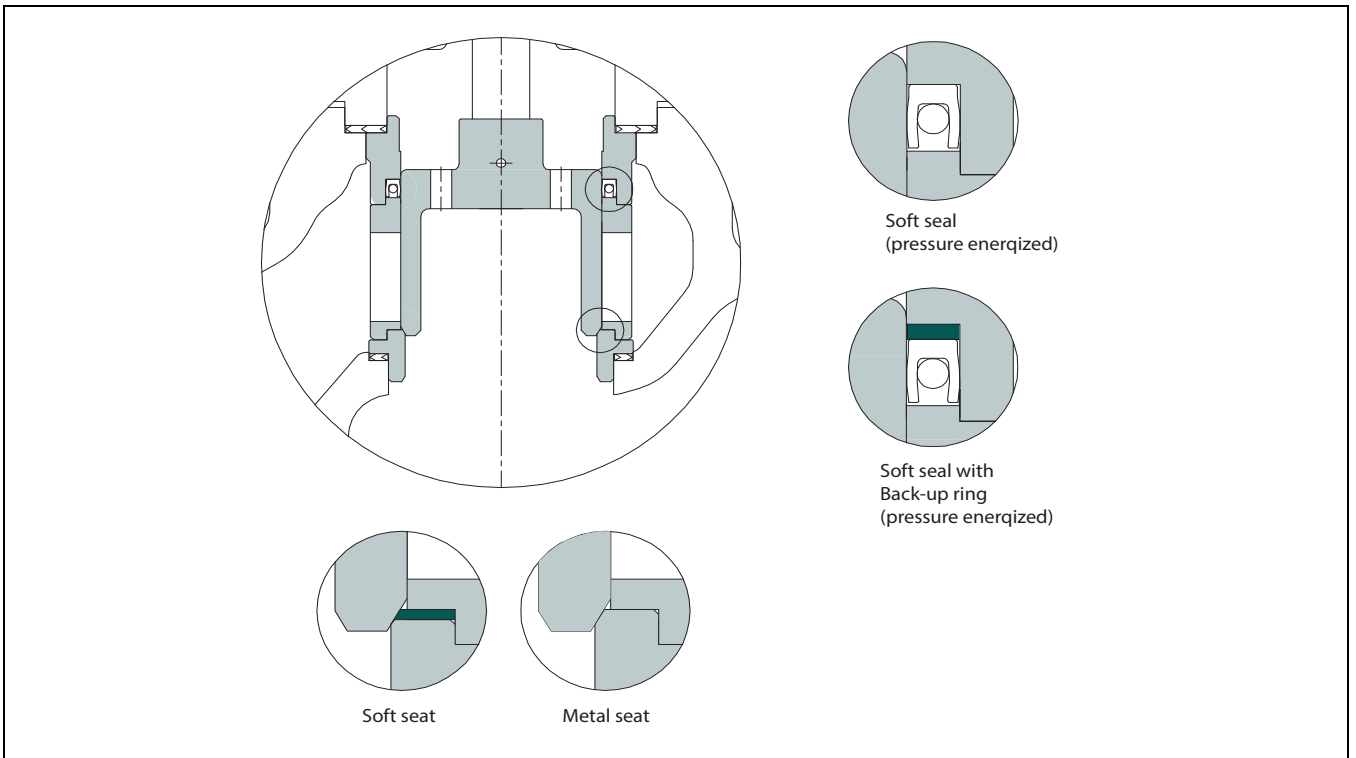

AU-Components & materials

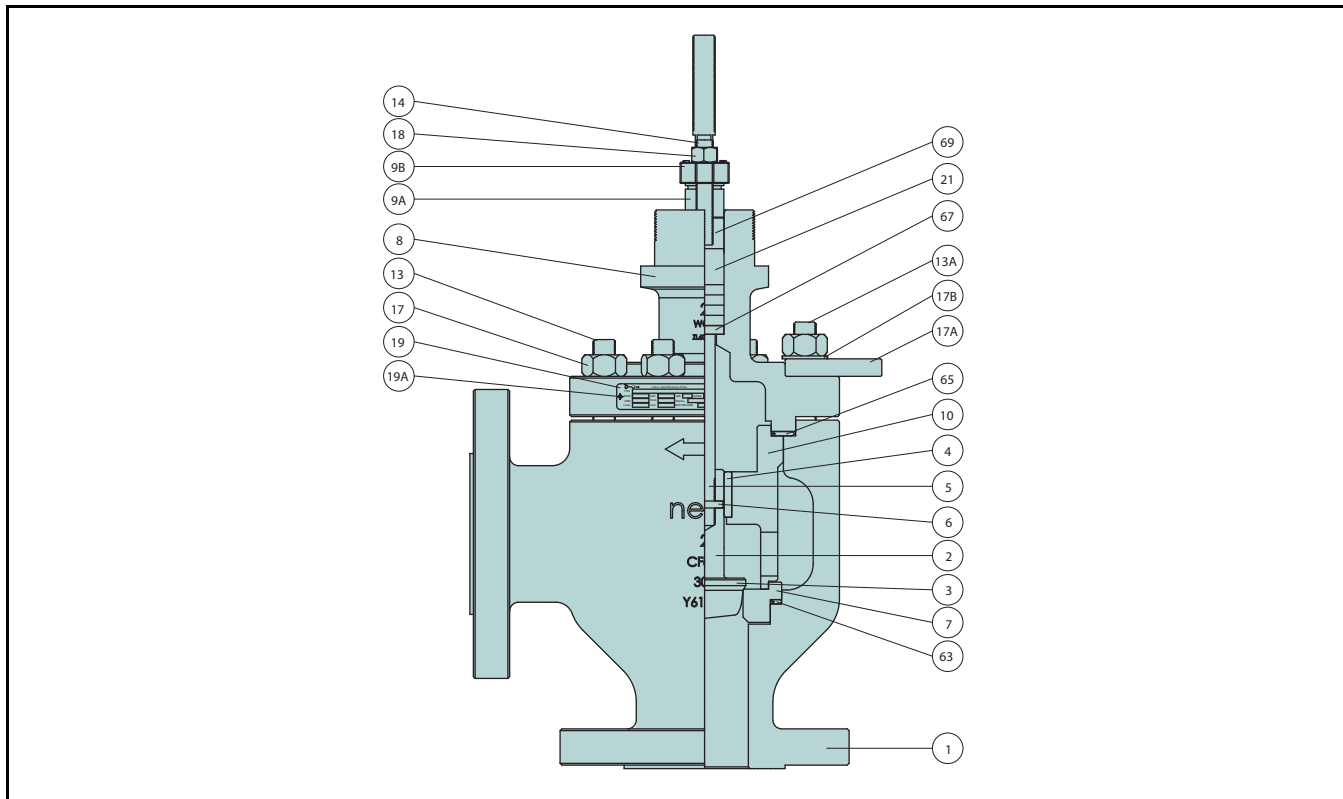

Part no.	Description	Material
1	BODY	A216 WCB / ALLOY STEEL AVAILABLE
2	PLUG SET	410 SS / 630 SS
3 *	PLUG	410 STAINLESS STEEL
5 *	STEM	630 STAINLESS STEEL + HCr
6 *	PLUG PIN	316 STAINLESS STEEL
4	GUIDE BUSHING	440C STAINLESS STEEL
7	SEAT RING	410 STAINLESS STEEL
8	BONNET	A216 WCB / ALLOY STAINLESS STEEL
9A	GLAND	304 STAINLESS STEEL
9B	GLAND FLANGE	A351 CF8
10	RETAINER	630 STAINLESS STEEL
13	STUD	A193 Gr.B7
13A	STUD	A193 Gr.B7
14	STUD	A193 Gr.B8
17	HEXAGON NUT	A194 Gr.2H
17A	LIFTING PLATE	JIS G3101-SS400
17B	SPRING WASHER	AISI 304
18	HEXAGON NUT	A194 Gr.8
19	IDENTIFICATION PLATE	304 STAINLESS STEEL
19A	RIVET	304 STAINLESS STEEL
21	LANTERN RING	304 STAINLESS STEEL
63	SEAT GASKET	S/W GASKET, 316 SS + GRAPHITE
65	BODY GASKET	S/W GASKET, 316 SS + GRAPHITE
67	PACKING SPACER	304 STAINLESS STEEL
69	PACKING RING	PTFE + CARBON FIBER, GRAPHITE

Material	Spare
A351 CF8M	
316 SS / 316 SS	Cat 3
316 STAINLESS STEEL	Cat 3
316 STAINLESS STEEL + HCr	Cat 3
316 STAINLESS STEEL	Cat 3
316 + COBALT BASED ALLOY	Cat 3
316 STAINLESS STEEL	Cat 3
A351 CF8M	
304 STAINLESS STEEL	
A351 CF8	
A351 CF8M	Cat 3
A193 Gr.B8(M)	
A193 Gr.B8(M)	
A193 Gr.B8	
A194 Gr.8(M)	
JIS G3101-SS400	
AISI 304	
A194 Gr.8	
304 STAINLESS STEEL	
304 STAINLESS STEEL	
304 STAINLESS STEEL	
S/W GASKET, 316 SS + GRAPHITE	Cat 1
S/W GASKET, 316 SS + GRAPHITE	Cat 1
304 STAINLESS STEEL	
PTFE + CARBON FIBER, GRAPHITE	Cat 1

- Note.
1. Plug/Seat Hard Facing(Cobalt based alloy) & Soft Seat are available
 2. Materials description
 316 SS : ASTM A276 TP316 or JIS 316 St. Steel
 410 SS : ASTM A276 TP410 or JIS 410 St. Steel
 440C SS : ASTM A276 TP440C or JIS 440C St. Steel
 17-4PH : ASTM A564 630(H1100) or JIS 630(H1100) St. Steel
 3. Above standard materials to be applicable depending on specic service conditions, other optional materials to consult Metso.
 4. Optional materials to meet to requirements of NACE MR 01-75 are available
 5. The materials are subject to change as equivalent depending on detail design
 6. The part no.3*, 5*, 6 *are delivered a*s a set with no.2

- Note.
1. Plug/Seat Hard Facing(Cobalt based alloy) & Soft Seat are available
 2. Materials description
 316 SS : ASTM A276 TP316 or JIS 316 St. Steel
 3. Above standard materials to be applicable depending on specic service conditions, other optional materials to consult Metso.
 4. Cryogenic application : ASTM A320 B8M & 8M for Studs(13) and Nuts(17)
 5. Optional materials to meet to requirements of NACE MR 01-75 are available
 6. The materials are subject to change as equivalent depending on detail design
 7. The part no.3*, 5*, 6 *are delivered as a set with no.2

AB-Components & materials

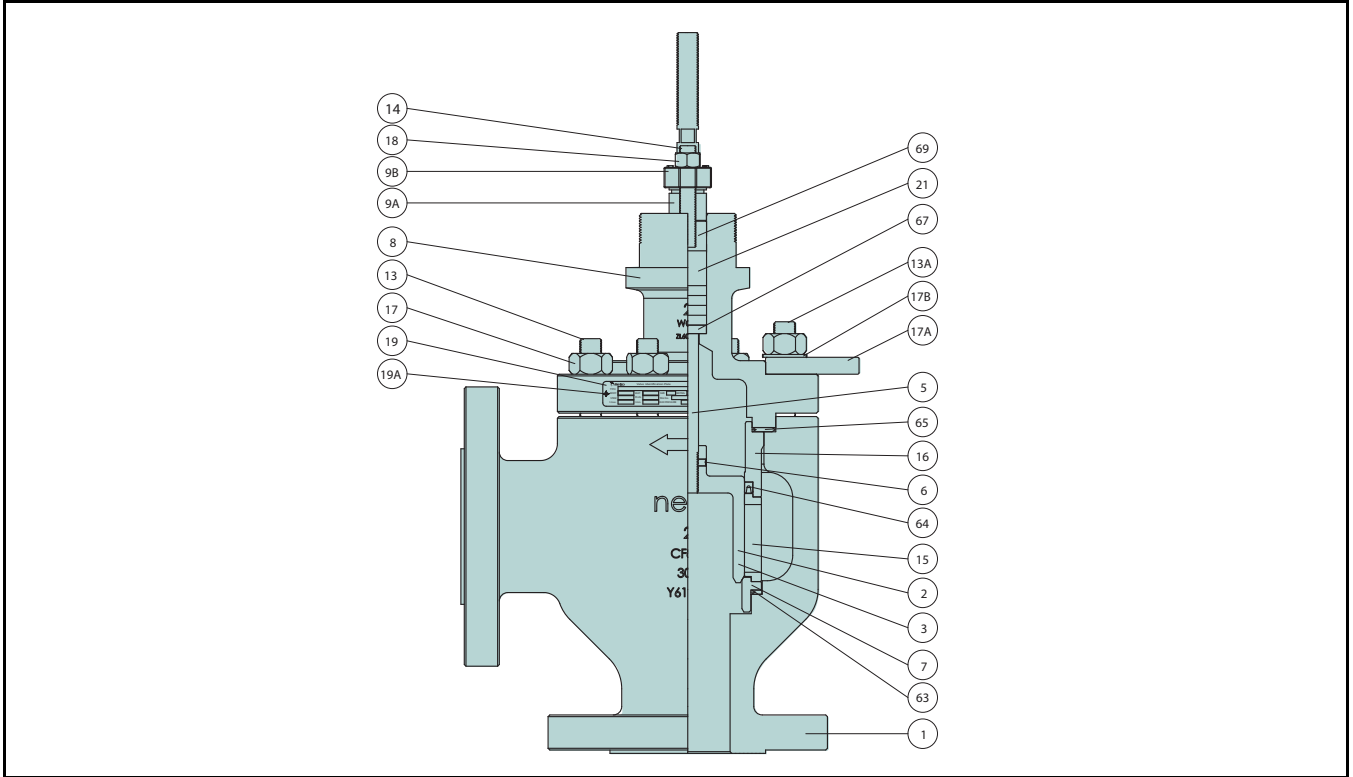

Part no.	Description	Material
1	BODY	A216 WCB / ALLOY STEEL AVAILABLE
2	PLUG SET	410 SS / 630 SS
3 *	PLUG	410 STAINLESS STEEL
5 *	STEM	630 STAINLESS STEEL + HCr
6 *	PLUG PIN	316 STAINLESS STEEL
7	SEAT RING	410 STAINLESS STEEL
8	BONNET	A216 WCB / ALLOY STAINLESS STEEL
9A	GLAND	304 STAINLESS STEEL
9B	GLAND FLANGE	A351 CF8
13	STUD	A193 Gr.B7
13A	STUD	A193 Gr.B7
14	STUD	A193 Gr.B8
15	CAGE	630 STAINLESS STEEL + HCr
16	CAGE GUIDE	630 STAINLESS STEEL + HCr
17	HEXAGON NUT	A194 Gr.2H
17A	LIFTING PLATE	JIS G3101-SS400
17B	SPRING WASHER	AISI 304
18	HEXAGON NUT	A194 Gr.8
19	IDENTIFICATION PLATE	304 STAINLESS STEEL
19A	RIVET	304 STAINLESS STEEL
21	LANTERN RING	304 STAINLESS STEEL
63	SEAT GASKET	S/W GASKET, 316 SS + GRAPHITE
64	SEAL RING	PTFE + GRAPHITE
65	BODY GASKET	S/W GASKET, 316 SS + GRAPHITE
67	PACKING SPACER	304 STAINLESS STEEL
69	PACKING RING	PTFE + CARBON FIBER, GRAPHITE

Material	Spare
A351 CF8M	
316 SS / 316 SS	Cat 3
316 STAINLESS STEEL	Cat 3
316 STAINLESS STEEL + HCr	Cat 3
316 STAINLESS STEEL	Cat 3
316 STAINLESS STEEL	Cat 3
A351 CF8M	
304 STAINLESS STEEL	
A351 CF8	
A193 Gr.B8(M)	
A193 Gr.B8(M)	
A193 Gr.B8	
316 SS + HCr / CF8M + HCr	Cat 3
316 SS + HCr / CF8M + HCr	Cat 3
A194 Gr.8(M)	
JIS G3101-SS400	
AISI 304	
A194 Gr.8	
304 STAINLESS STEEL	
304 STAINLESS STEEL	
304 STAINLESS STEEL	
S/W GASKET, 316 SS + GRAPHITE	Cat 1
PTFE + GRAPHITE	Cat 1
S/W GASKET, 316 SS + GRAPHITE	Cat 1
304 STAINLESS STEEL	
PTFE + CARBON FIBER, GRAPHITE	Cat 1

- Note.
- 1.Plug/Seat Hard Facing(Cobalt based alloy) & Soft Seat are available
 2. Materials description
316 SS : ASTM A276 TP316 or JIS 316 St. Steel
410 SS : ASTM A276 TP410 or JIS 410 St. Steel
440C SS : ASTM A276 TP440C or JIS 440C St. Steel
17-4PH : ASTM A564 630(H1100) or JIS 630(H1100) St. Steel
 3. Above standard materials to be applicable depending on specific service conditions, other optional materials to consult Metso
 4. Optional materials to meet to requirements of NACE MR 01-75 are available
 5. The materials are subject to change as equivalent depending on detail design
 6. The part no.3*, 5*, 6 *are delivered as a set with no.2

- Note.
1. Plug/Seat Hard Facing(Cobalt based alloy) & Soft Seat are available
 2. Materials description
316 SS : ASTM A276 TP316 or JIS 316 St. Steel
 3. Above standard materials to be applicable depending on specific service conditions, other optional materials to consult Metso.
 4. Cryogenic application : ASTM A320 B8M & 8M for Studs(13) and Nuts(17)
 5. Optional materials to meet to requirements of NACE MR 01-75 are available
 6. The materials are subject to change as equivalent depending on detail design
 7. The part no.3*, 5*, 6 *are delivered as a set with no.2

AM-Components & materials

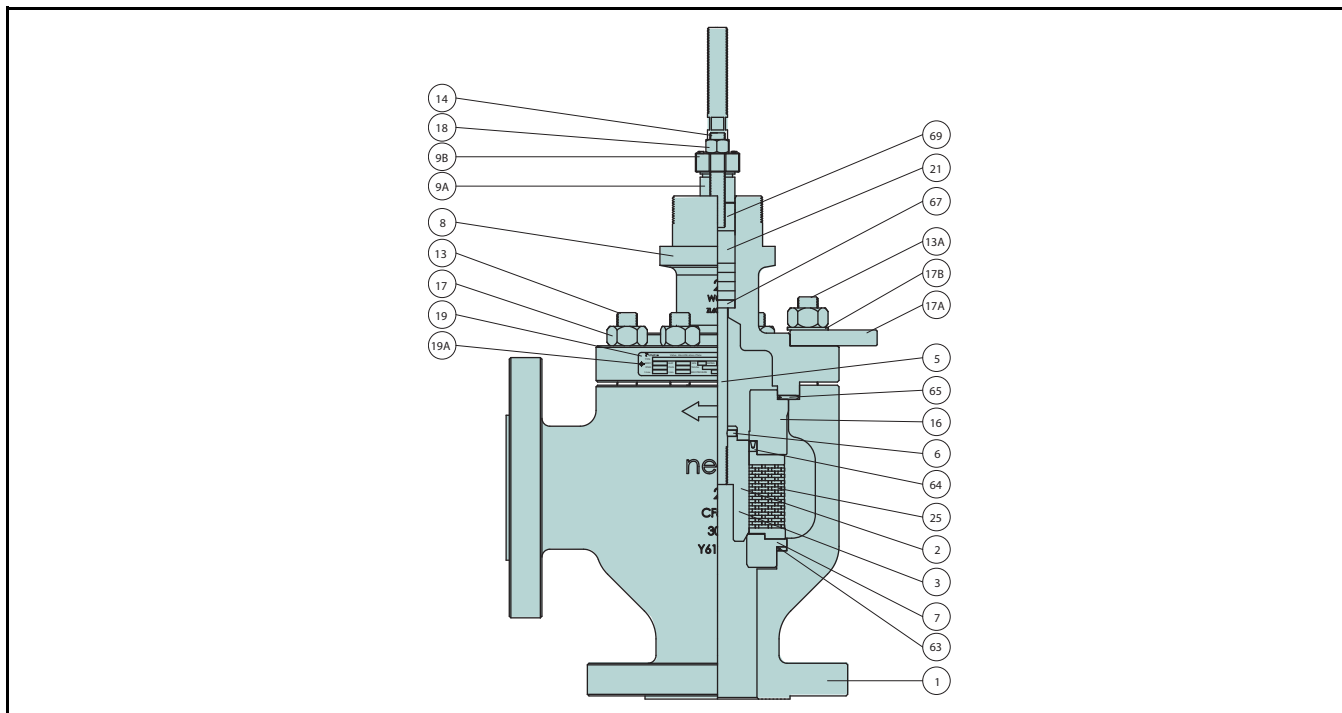

Part no.	Description	Material
1	BODY	A216 WCB / ALLOY STEEL AVAILABLE
2	PLUG SET	420(J2) SS / 630 SS
3 *	PLUG	420(J2) STAINLESS STEEL
5 *	STEM	630 STAINLESS STEEL + HCr
6 *	PLUG PIN	316 STAINLESS STEEL
7	SEAT RING	410 STAINLESS STEEL
8	BONNET	A216 WCB / ALLOY STEEL AVAILABLE
9A	GLAND	304 STAINLESS STEEL
9B	GLAND FLANGE	A351 CF8
13	STUD	A193 Gr.B7
13A	STUD	A193 Gr.B7
14	STUD	A193 Gr.B8
16	CAGE GUIDE	420(J2) STAINLESS STEEL
17	HEXAGON NUT	A194 Gr.2H
17A	LIFTING PLATE	JIS G3101-SS400
17B	SPRING WASHER	AISI 304
18	HEXAGON NUT	A194 Gr.8
19	IDENTIFICATION PLATE	304 STAINLESS STEEL
19A	RIVET	304 STAINLESS STEEL
21	LANTERN RING	304 STAINLESS STEEL
25	DISK STACK	420(J2) STAINLESS STEEL
63	SEAT GASKET	S/W GASKET, 316 SS + GRAPHITE
64	SEAL RING	PTFE + GRAPHITE
65	BODY GASKET	S/W GASKET, 316 SS + GRAPHITE
67	PACKING SPACER	304 STAINLESS STEEL
69	PACKING RING	PTFE + CARBON FIBER, GRAPHITE

Material	Spare
A351 CF8M	
420(J2) SS / 316 SS	Cat 3
420(J2) STAINLESS STEEL	Cat 3
316 STAINLESS STEEL + HCr	Cat 3
316 STAINLESS STEEL	Cat 3
316 STAINLESS STEEL	Cat 3
A351 CF8M	
304 STAINLESS STEEL	
A351 CF8	
A193 Gr.B8(M)	
A193 Gr.B8(M)	
A193 Gr.B8	
420(J2) STAINLESS STEEL	Cat 3
A194 Gr.8(M)	
JIS G3101-SS400	
AISI 304	
A194 Gr.8	
304 STAINLESS STEEL	
304 STAINLESS STEEL	
304 STAINLESS STEEL	
420(J2) STAINLESS STEEL	Cat 3
S/W GASKET, 316 SS + GRAPHITE	Cat 1
PTFE + GRAPHITE	Cat 1
S/W GASKET, 316 SS + GRAPHITE	Cat 1
304 STAINLESS STEEL	
PTFE + CARBON FIBER, GRAPHITE	Cat 1

Note.

1. Plug/Seat Hard Facing(Cobalt based alloy) & Soft Seat are available
2. Materials description
316 SS : ASTM A276 TP316 or JIS 316 St. Steel
410 SS : ASTM A276 TP410 or JIS 410 St. Steel
420 SS : ASTM A276 TP420 or JIS 420 St. Steel
440C SS : ASTM A276 TP440C or JIS 440C St. Steel
17-4PH : ASTM A564 630(H1100) or JIS 630(H1100) St. Steel
3. Above standard materials to be applicable depending on specic service conditions, other optional materials to consult Metso.
4. Optional materials to meet to requirements of NACE MR 01-75 are available
5. The materials are subject to change as equivalent depending on detail design
6. The part no.3*, 5 *, 6 *are deli*vered a*s a set with no.2

Note.

1. Plug/Seat Hard Facing(Cobalt based alloy) & Soft Seat are available
2. Materials description
316 SS : ASTM A276 TP316 or JIS 316 St. Steel
420 SS : ASTM A276 TP420 or JIS 420 St. Steel
3. Above standard materials to be applicable depending on specic service conditions, other optional materials to consult Metso.
4. Cryogenic application : ASTM A320 B8M & 8M for Studs(13) and Nuts(17)
5. Optional materials to meet to requirements of NACE MR 01-75 are available
6. The materials are subject to change as equivalent depending on detail design
7. The part no.3* , 5* , 6* are delivered as a set with no.2

Rated Cv and trim table (Angle single seat, unbalanced type, series AU)

Sign	TRIM TYPE	Sign	TRIM CHARACTERISTIC	Sign	RATED C																
					Description	Body Size and Stroke															
						1/2" Str.	3/4" Str.	1" Str.	1-1/2" Str.	2" Str.	3" Str.	4" Str.	6" Str.								
A	General plug	L	Linear	FC	General / Full capacity	7 (20)	9 (20)	13.5 (20)	28 (20)	49 (20)	100 (40)	190 (40)	295 (60)								
				E	Equal %	1A	General / 1-Step reduction	4 (20)	5.5 (20)	8.5 (20)	16 (20)	28 (20)	70 (40)	120 (40)	165 (60)						
				2A	General / 2-Step reduction	2.3 (20)	3 (20)	5.4 (20)	10.5 (20)	17 (20)	42 (40)	72 (40)	85 (60)								
				3A	General / 3-Step reduction	1.5 (20)	2 (20)	3.1 (20)	6 (20)	10 (20)	25 (40)	42 (40)	50 (60)								
				4A	General / 4-Step reduction	0.8 (20)	1.2 (20)	2 (20)	4 (20)												
				5A	General / 5-Step reduction	0.5 (20)	0.7 (20)	1.2 (20)	2.2 (20)												
				6A	General / 6-Step reduction	0.3 (20)	0.4 (20)	0.8 (20)	1.2 (20)												
				FT	Tendril / Full capacity	7 (20)	9 (20)	13.5 (20)	28 (20)	49 (20)	100 (40)	190 (40)	295 (60)								
				1T	Tendril / 1-Step reduction	4 (20)	5.5 (20)	8.5 (20)	16 (20)	28 (20)	70 (40)	120 (40)	165 (60)								
				2T	Tendril / 2-Step reduction	2.3 (20)	3 (20)	5.4 (20)	10.5 (20)	17 (20)	42 (40)	72 (40)	85 (60)								
				3T	Tendril / 3-Step reduction	1.5 (20)	2 (20)	3.1 (20)	6 (20)	10 (20)	25 (40)	42 (40)	50 (60)								
				4T	Tendril / 4-Step reduction	0.8 (20)	1.2 (20)	2 (20)	4 (20)												
				5T	Tendril / 5-Step reduction	0.5 (20)	0.7 (20)	1.2 (20)	2.2 (20)												
				6T	Tendril / 6-Step reduction	0.3 (20)	0.4 (20)	0.8 (20)	1.2 (20)												
C	Micro plug	L	Linear	FC	General / Full capacity	0.1 (20)	0.1 (20)	0.1 (20)													
				1A	General / 1-Step reduction	0.06 (20)	0.06 (20)	0.06 (20)													
				2A	General / 2-Step reduction	0.03 (20)	0.03 (20)	0.03 (20)													
				3A	General / 3-Step reduction	0.01 (20)	0.01 (20)	0.01 (20)													
				4A	General / 4-Step reduction	0.006 (20)	0.006 (20)	0.006 (20)													
				5A	General / 5-Step reduction	0.003 (20)	0.003 (20)	0.003 (20)													
Y	Special	Y	Special	YY	Special	Contact Metso for Cv details															

* Rated Cv is separated depending on the trim type & trim characteristic.
 *Optional rated Cv to meet to specific Cv are available.
 *Micro(Mini flow) trim is available.
 *(Str.) is the valve stroke.
 *For trims without the specified Cv values, please contact Metso Korea.

Rated Cv and trim table (Angle single seat, balanced type, series AB)

Sign	TRIM TYPE	Sign	TRIM CHARACTERISTIC	Sign	RATED Cv														
					Description	Body Size and Stroke													
						2" Str.	3" Str.	4" Str.	6" Str.	8" Str.	10" Str.	12" Str.	14" Str.	16" Str.					
A P	General plug Pilot balanced plug	L	Linear	FC	General / Full capacity	82 (40)	174 (50)	280 (50)	470 (60)	810 (70)	1250 (80)	1810 (120)	2530 (140)	2960 (160)					
				1A	General / 1-Step reduction	74 (40)	104 (50)	170 (50)	284 (60)	500 (70)	760 (80)	1100 (120)	1540 (140)	1780 (160)					
				2A	General / 2-Step reduction	44 (40)	62 (50)	100 (50)	170 (60)	320 (70)	460 (80)	680 (120)	940 (140)	1080 (160)					
				3A	General / 3-Step reduction	26 (40)	40 (50)	64 (50)	100 (60)	200 (70)	280 (80)	420 (120)	580 (140)	660 (160)					
				FT	Tendril 1 / Full capacity	52 (40)	102 (50)	160 (50)	290 (60)	460 (70)	630 (80)	980 (120)	1300 (140)	1580 (160)					
				1T	Tendril 1 / 1-Step reduction	40 (40)	75 (50)	120 (50)	220 (60)	340 (70)	460 (80)	735 (120)	985 (140)	1145 (160)					
				2T	Tendril 1 / 2-Step reduction	27 (40)	40 (50)	70 (50)	130 (60)	195 (70)	255 (80)	405 (120)	565 (140)	670 (160)					
				3T	Tendril 1 / 3-Step reduction	10 (40)	21 (50)	46 (50)	75 (60)	105 (70)	140 (80)	240 (120)	310 (140)	415 (160)					
				FM	Tendril 2 / Full capacity	50 (40)	100 (50)	155 (50)	280 (60)	425 (70)	590 (80)	920 (120)	1240 (140)	1530 (160)					
				1M	Tendril 2 / 1-Step reduction	35 (40)	74 (50)	115 (50)	215 (60)	330 (70)	450 (80)	720 (120)	970 (140)	1130 (160)					
		2M	Tendril 2 / 2-Step reduction	23 (40)	33 (50)	65 (50)	120 (60)	190 (70)	240 (80)	380 (120)	550 (140)	640 (160)							
		3M	Tendril 2 / 3-Step reduction	8 (40)	18 (50)	38 (50)	67 (60)	100 (70)	130 (80)	220 (120)	290 (140)	390 (160)							
		E	Equal %	FC	General / Full capacity	76 (40)	160 (50)	256 (50)	430 (60)	740 (70)	1140 (80)	1650 (120)	2300 (140)	2700 (160)					
				1A	General / 1-Step reduction	46 (40)	98 (50)	156 (50)	260 (60)	450 (70)	680 (80)	1000 (120)	1400 (140)	1640 (160)					
				2A	General / 2-Step reduction	28 (40)	60 (50)	94 (50)	156 (60)	270 (70)	410 (80)	640 (120)	840 (140)	980 (160)					
				3A	General / 3-Step reduction	18 (40)	35 (50)	60 (50)	96 (60)	164 (70)	250 (80)	384 (120)	520 (140)	600 (160)					
				FT	Tendril 1 / Full capacity	50 (40)	82 (50)	135 (50)	235 (60)	370 (70)	500 (80)	840 (120)	1110 (140)	1400 (160)					
				1T	Tendril 1 / 1-Step reduction	35 (40)	58 (50)	95 (50)	170 (60)	265 (70)	370 (80)	600 (120)	785 (140)	1020 (160)					
				2T	Tendril 1 / 2-Step reduction	20 (40)	35 (50)	58 (50)	100 (60)	170 (70)	225 (80)	355 (120)	480 (140)	600 (160)					
				3T	Tendril 1 / 3-Step reduction	10 (40)	20 (50)	32 (50)	58 (60)	105 (70)	125 (80)	205 (120)	290 (140)	350 (160)					
FM	Tendril 2 / Full capacity			47 (40)	74 (50)	130 (50)	230 (60)	330 (70)	470 (80)	770 (120)	1050 (140)	1320 (160)							
1M	Tendril 2 / 1-Step reduction			33 (40)	56 (50)	92 (50)	165 (60)	245 (70)	330 (80)	570 (120)	720 (140)	960 (160)							
2M	Tendril 2 / 2-Step reduction	19 (40)	33 (50)	52 (50)	95 (60)	145 (70)	190 (80)	330 (120)	430 (140)	550 (160)									
3M	Tendril 2 / 3-Step reduction	8 (40)	16 (50)	25 (50)	52 (60)	80 (70)	110 (80)	190 (120)	270 (140)	295 (160)									
Y	Special	Y	Special	YY	Special	Contact Metso for Cv details													

Rated Cv and Trim Table (Angle, Omega Trim, AM)

Sign	TRIM TYPE	Sign	TRIM CHARACTERISTIC	Sign	RATED Cv																
					Description	Body size and stroke															
						1" Str.	1.5" Str.	2" Str.	3" Str.	4" Str.	6" Str.	8" Str.	10" Str.	12" Str.	14" Str.	16" Str.					
A P U	Balanced plug Pilot balanced plug Unbalanced plug	L	Linear	FG	Full capa. / Gas	8 (20)	18 (20)	30 (40)	62 (50)	96 (50)	168 (60)	290 (70)	440 (80)	640 (120)	880 (140)	1160 (160)					
				FL	Full capa. / Liquid																
				1G	1-Step red. / Gas	5 (20)	12 (20)	20 (40)	40 (50)	60 (50)	100 (60)	180 (70)	270 (80)	400 (120)	530 (140)	700 (160)					
				1L	1-Step red. / Liquid																
				2G	2-Step red. / Gas	3 (20)	26 (20)	40 (40)	64 (50)	110 (50)	160 (60)	240 (70)	320 (80)	420 (120)	320 (140)	420 (160)					
				2L	2-Step red. / Liquid																
				3G	3-Step red. / Gas	2 (20)	5 (20)	8 (40)	16 (50)	24 (50)	42 (60)	70 (70)	100 (80)	150 (120)	200 (140)	260 (160)					
				3L	3-Step red. / Liquid																
				E	Equal %	FG	Full capa. / Gas	5 (20)	10 (20)	18 (40)	38 (50)	60 (50)	104 (60)	176 (70)	268 (80)	390 (120)	540 (140)	710 (160)			
		FL	Full capa. / Liquid																		
		1G	1-Step red. / Gas			2.5 (20)	6 (20)	11 (40)	24 (50)	36 (50)	64 (60)	108 (70)	164 (80)	236 (120)	328 (140)	430 (160)					
		1L	1-Step red. / Liquid																		
		2G	2-Step red. / Gas			1.2 (20)	3 (20)	5 (40)	12 (50)	18 (50)	32 (60)	54 (70)	82 (80)	118 (120)	164 (140)	214 (160)					
		2L	2-Step red. / Liquid																		
		3G	3-Step red. / Gas			0.6 (20)	1.5 (20)	2 (40)	6 (50)	9 (50)	16 (60)	27 (70)	40 (80)	60 (120)	82 (140)	106 (160)					
		3L	3-Step red. / Liquid																		
		Y	Special			Y	Special	YY	Special	Contact Metso for Cv details											

* Rated Cv is separated depending on the trim type & trim characteristic.
 *Optional rated Cv to meet to specific Cv are available.
 *Micro(Mini flow) trim is available.
 *(Str.) is the valve stroke.Subject to change without prior notice.
 *For trims without the specified Cv values, please contact Metso Korea.

AU Series Cv vs Travel (General Contoured)

Size: 1/2" ~ 6"

Flow Characteristic : LINEAR

Valve Travel [%]							10	20	30	40	50	60	70	80	90	100
F _L							0.94	0.93	0.91	0.90	0.89	0.89	0.88	0.88	0.87	0.77
Valve Size		Orifice Dia.			Travel		Rated Cv									
Inch	mm	Sign	Inch	mm	Inch	mm										
1/2"	15	FC	0.6	15.7	0.8	20	0.53	1.27	1.95	2.66	3.38	4.09	4.76	5.51	6.67	7
		1A	0.4	11.0			0.36	0.74	1.23	1.61	1.99	2.37	2.72	3.05	3.41	4
		2A	0.3	8.0			0.28	0.53	0.79	1.07	1.32	1.52	1.71	1.88	2.03	2.3
		3A	0.3	6.4			0.19	0.36	0.52	0.67	0.82	0.97	1.15	1.28	1.38	1.5
		4A	0.3	6.4			0.09	0.17	0.25	0.32	0.40	0.47	0.54	0.61	0.68	0.8
		5A	0.3	6.4			0.06	0.11	0.15	0.20	0.25	0.30	0.35	0.40	0.45	0.5
		6A	0.3	6.4			0.04	0.07	0.10	0.12	0.15	0.18	0.21	0.24	0.27	0.3
3/4"	20	FC	0.7	17.2	0.8	20	0.85	1.68	2.57	3.31	4.04	4.74	5.43	6.18	7.61	9
		1A	0.5	13.0			0.35	0.82	1.40	2.17	2.78	3.39	3.98	4.53	5.03	5.5
		2A	0.4	9.0			0.29	0.74	1.08	1.40	1.73	2.13	2.37	2.60	2.80	3
		3A	0.3	7.2			0.24	0.44	0.63	0.81	0.99	1.16	1.32	1.47	1.62	2
		4A	0.3	6.4			0.13	0.24	0.36	0.48	0.60	0.72	0.84	0.96	1.08	1.2
		5A	0.3	6.4			0.08	0.15	0.22	0.28	0.35	0.42	0.49	0.56	0.63	0.7
		6A	0.3	6.4			0.05	0.09	0.13	0.17	0.21	0.25	0.28	0.32	0.36	0.4
1"	25	FC	0.9	22.3	0.8	20	1.29	2.62	4.02	5.42	6.83	8.13	8.90	10.25	11.93	13.5
		1A	0.6	15.0			0.77	1.54	2.31	3.15	3.92	4.68	5.42	6.12	7.00	8.5
		2A	0.5	11.5			0.46	0.94	1.43	1.94	2.46	3.02	3.52	4.00	4.44	5.4
		3A	0.4	9.0			0.28	0.56	0.86	1.16	1.47	1.77	2.07	2.36	2.66	3.1
		4A	0.3	7.2			0.18	0.37	0.57	0.78	0.99	1.20	1.41	1.61	1.79	2
		5A	0.3	6.4			0.11	0.23	0.35	0.47	0.59	0.71	0.83	0.95	1.07	1.2
		6A	0.3	6.4			0.07	0.14	0.21	0.28	0.34	0.41	0.48	0.55	0.62	0.8
1-1/2"	40	FC	1.2	30.0	0.8	20	2.64	5.38	8.46	11.77	15.22	18.77	21.56	24.09	26.50	28
		1A	0.8	21.5			1.63	3.16	4.70	6.25	7.90	9.52	11.12	12.68	14.18	16
		2A	0.6	16.0			0.95	1.89	2.86	3.86	4.88	5.88	6.90	7.92	8.86	10.5
		3A	0.5	12.5			0.57	1.13	1.72	2.33	2.96	3.58	4.19	4.78	5.33	6
		4A	0.4	10.0			0.37	0.74	1.14	1.54	1.96	2.38	2.79	3.18	3.55	4
		5A	0.3	7.0			0.19	0.38	0.57	0.78	0.99	1.19	1.40	1.60	1.78	2.2
		6A	0.3	6.4			0.12	0.24	0.36	0.47	0.59	0.71	0.83	0.95	1.06	1.2
2"	50	FC	1.7	43.9	0.8	20	4.13	9.24	14.48	19.71	25.09	30.56	35.97	40.01	44.64	49
		1A	1.3	33.4			2.27	4.97	7.88	10.94	13.72	16.51	19.28	22.03	24.97	28
		2A	0.8	21.5			1.26	2.76	4.37	6.05	7.77	9.53	11.23	12.73	14.32	17
		3A	0.6	16.0			0.82	1.78	2.80	3.86	4.93	5.98	7.01	7.98	8.89	10
3"	80	FC	2.8	72.0	1.5	40	9.96	21.06	32.40	42.65	52.98	63.70	76.67	86.07	91.15	100
		1A	1.9	47.0			5.35	11.64	18.74	26.58	33.66	40.46	47.18	53.74	60.34	70
		2A	1.3	34.0			3.47	7.21	11.20	15.38	19.69	24.06	28.45	31.99	35.66	42
		3A	1.0	25.0			2.17	4.47	6.86	9.32	11.81	14.29	16.73	19.08	21.29	25
4"	100	FC	3.6	91.5	1.5	40	12.67	27.12	47.27	66.04	85.99	106.88	127.85	147.47	167.93	190
		1A	2.4	60.0			7.32	15.77	25.33	36.43	51.05	63.30	75.78	88.32	103.94	120
		2A	1.7	43.0			7.02	13.84	20.64	27.41	34.07	43.44	50.85	57.09	63.09	72
		3A	1.3	32.0			4.03	8.16	12.45	16.82	21.18	25.44	29.51	33.31	37.67	42
6"	150	FC	4.5	115.0	2.4	60	28.43	57.15	86.05	112.26	136.07	159.16	181.59	212.57	263.12	295
		1A	3.0	75.0			16.09	32.01	47.67	63.09	78.18	93.11	105.76	117.42	137.91	165.
		2A	1.8	46.5			8.78	17.43	25.90	34.15	42.13	49.78	57.07	63.94	71.49	85
		3A	1.4	35.5			4.32	9.07	14.14	19.45	24.88	30.32	35.64	40.72	45.42	50

ANSI Class : 150# ~ 600#

Size : 1/2" ~ 6"

Flow Characteristic : EQ%

Valve Travel [%]							10	20	30	40	50	60	70	80	90	100
F _L							0.94	0.94	0.93	0.93	0.92	0.90	0.89	0.88	0.87	0.77
Valve Size		Orifice Dia.			Travel		Rated Cv									
Inch	mm	Sign	Inch	mm	Inch	mm										
1/2"	15	FC	0.6	15.7	0.8	20	0.16	0.36	0.56	0.89	1.38	2.16	3.42	4.84	6.44	7
		1A	0.4	11.0			0.06	0.16	0.31	0.49	0.78	1.46	2.17	2.88	3.53	4
		2A	0.3	8.0			0.08	0.16	0.23	0.34	0.59	0.94	1.37	1.70	2.01	2.3
		3A	0.3	6.4			0.05	0.09	0.14	0.20	0.35	0.56	0.82	1.11	1.33	1.5
		4A	0.3	6.4			0.02	0.04	0.06	0.08	0.16	0.28	0.41	0.54	0.66	0.8
		5A	0.3	6.4			0.01	0.02	0.04	0.05	0.10	0.17	0.25	0.33	0.41	0.5
		6A	0.3	6.4			0.01	0.01	0.02	0.03	0.06	0.11	0.15	0.20	0.25	0.3
3/4"	20	FC	0.7	17.2	0.8	20	0.24	0.45	0.67	1.07	1.85	2.93	4.02	5.23	7.13	9
		1A	0.5	13.0			0.06	0.20	0.40	0.67	1.11	1.79	2.79	3.71	4.74	5.5
		2A	0.4	9.0			0.05	0.17	0.28	0.45	0.78	1.20	1.80	2.35	2.72	3
		3A	0.3	7.2			0.04	0.09	0.15	0.21	0.41	0.68	1.00	1.30	1.67	2
		4A	0.3	6.4			0.03	0.06	0.09	0.13	0.25	0.42	0.62	0.82	1.01	1.2
		5A	0.3	6.4			0.01	0.03	0.05	0.08	0.14	0.23	0.34	0.45	0.58	0.7
		6A	0.3	6.4			0.01	0.02	0.03	0.04	0.08	0.14	0.21	0.27	0.33	0.4
1"	25	FC	0.9	22.3	0.8	20	0.27	0.57	0.91	1.55	2.75	4.66	7.08	9.49	11.63	13.5
		1A	0.6	15.0			0.12	0.29	0.51	0.83	1.56	2.70	4.14	5.61	7.03	8.5
		2A	0.5	11.5			0.07	0.19	0.33	0.53	0.97	1.67	2.65	3.59	4.37	5.4
		3A	0.4	9.0			0.03	0.09	0.19	0.32	0.58	1.00	1.52	2.05	2.54	3.1
		4A	0.3	7.2			0.03	0.08	0.13	0.22	0.40	0.67	1.00	1.35	1.70	2
		5A	0.3	6.4			0.03	0.05	0.08	0.13	0.25	0.43	0.64	0.85	1.06	1.2
		6A	0.3	6.4			0.01	0.03	0.04	0.07	0.14	0.24	0.35	0.46	0.59	0.8
1-1/2"	40	FC	1.2	30.0	0.8	20	0.45	1.12	2.00	3.07	5.91	10.57	16.18	21.57	25.66	28
		1A	0.8	21.5			0.23	0.58	1.06	1.69	3.16	5.36	7.97	10.69	13.44	16
		2A	0.6	16.0			0.20	0.44	0.71	1.02	1.88	3.25	4.93	6.71	8.59	10.5
		3A	0.5	12.5			0.09	0.22	0.40	0.62	1.13	2.02	3.17	4.26	5.21	6
		4A	0.4	10.0			0.05	0.14	0.26	0.41	0.79	1.36	2.08	2.83	3.45	4
		5A	0.3	7.0			0.03	0.08	0.13	0.21	0.39	0.69	1.07	1.43	1.74	2.2
		6A	0.3	6.4			0.03	0.06	0.09	0.13	0.23	0.40	0.59	0.78	0.98	1.2
2"	50	FC	1.7	43.9	0.8	20	1.21	2.46	3.31	5.12	9.42	16.83	26.55	36.59	44.52	49
		1A	1.3	33.4			0.32	0.82	1.51	2.87	5.48	9.31	13.77	18.31	23.17	28
		2A	0.8	21.5			0.17	0.47	0.88	1.63	3.18	5.47	8.21	11.09	13.68	17
		3A	0.6	16.0			0.15	0.37	0.66	1.02	1.89	3.29	5.01	6.71	8.41	10
3"	80	FC	2.8	72.0	1.5	40	2.01	4.47	7.37	12.28	22.52	38.62	62.02	79.57	90.09	100
		1A	1.9	47.0			1.00	2.51	4.50	6.96	12.95	23.65	36.15	47.82	58.70	70
		2A	1.3	34.0			0.73	1.61	2.64	3.95	7.53	13.57	21.26	28.97	34.99	42
		3A	1.0	25.0			0.36	0.89	1.59	2.46	4.51	8.08	12.55	16.82	20.78	25
4"	100	FC	3.6	91.5	1.5	40	2.90	6.72	11.48	17.16	29.35	56.26	86.65	120.90	153.84	190
		1A	2.4	60.0			1.56	3.77	6.63	10.11	18.42	32.83	55.27	77.53	98.63	120
		2A	1.7	43.0			1.45	3.05	4.82	8.10	14.86	24.20	35.22	49.81	61.14	72
		3A	1.3	32.0			0.88	1.82	2.84	4.44	8.42	14.38	21.12	27.79	34.17	42
6"	150	FC	4.5	115.0	2.4	60	4.23	9.72	16.43	25.73	49.58	89.69	140.01	195.77	256.78	295
		1A	3.0	75.0			2.83	6.73	11.68	17.72	31.53	53.90	88.38	113.11	140.55	165
		2A	1.8	46.5			1.36	3.61	6.68	10.62	17.82	28.66	42.88	57.38	71.53	85
		3A	1.4	35.5			0.91	1.90	2.95	4.26	7.77	13.68	21.42	29.72	37.96	50

NOTE
 Cv : Valve flow coefficient
 FL: Liquid pressure recovery factor
 FC: Full Capacity
 2A: 2-Step reduction
 4A: 4-Step reduction

1A: 1-Step reduction
 3A: 3-Step reduction
 5A: 5-Step reduction

Contoured Trim (with Tendril 1)

ANSI Class : 150# ~ 600#

Size : 1/2" ~ 4"

Flow Characteristic : LINEAR

Valve Travel [%]							10	20	30	40	50	60	70	80	90	100
FL							0.95	0.95	0.95	0.94	0.94	0.94	0.93	0.93	0.91	0.91
Valve Size		Orifice Dia.			Travel		Rated Cv									
Inch	mm	Sign	Inch	mm	Inch	mm										
1/2"	15	FT	0.6	15.7	0.8	20	0.53	1.27	1.95	2.66	3.38	4.09	4.76	5.51	6.67	7
		1T	0.4	11.0			0.36	0.74	1.23	1.61	1.99	2.37	2.72	3.05	3.41	4
		2T	0.3	8.0			0.28	0.53	0.79	1.07	1.32	1.52	1.71	1.88	2.03	2.3
		3T	0.3	6.4			0.19	0.36	0.52	0.67	0.82	0.97	1.15	1.28	1.38	1.5
		4T	0.3	6.4			0.09	0.17	0.25	0.32	0.40	0.47	0.54	0.61	0.68	0.8
		5T	0.3	6.4			0.06	0.11	0.15	0.20	0.25	0.30	0.35	0.40	0.45	0.5
		6T	0.3	6.4			0.04	0.07	0.10	0.12	0.15	0.18	0.21	0.24	0.27	0.3
3/4"	20	FT	0.7	17.2	0.8	20	0.85	1.68	2.57	3.31	4.04	4.74	5.43	6.18	7.61	9
		1T	0.5	13.0			0.35	0.82	1.40	2.17	2.78	3.39	3.98	4.53	5.03	5.5
		2T	0.4	9.0			0.29	0.74	1.08	1.40	1.73	2.13	2.37	2.60	2.80	3
		3T	0.3	7.2			0.24	0.44	0.63	0.81	0.99	1.16	1.32	1.47	1.62	2
		4T	0.3	6.4			0.13	0.24	0.36	0.48	0.60	0.72	0.84	0.96	1.08	1.2
		5T	0.3	6.4			0.08	0.15	0.22	0.28	0.35	0.42	0.49	0.56	0.63	0.7
		6T	0.3	6.4			0.05	0.09	0.13	0.17	0.21	0.25	0.28	0.32	0.36	0.4
1"	25	FT	0.9	22.3	0.8	20	1.29	2.62	4.02	5.42	6.83	8.13	8.90	10.25	11.93	13.5
		1T	0.6	15.0			0.77	1.54	2.31	3.15	3.92	4.68	5.42	6.12	7.00	8.5
		2T	0.5	11.5			0.46	0.94	1.43	1.94	2.46	3.02	3.52	4.00	4.44	5.4
		3T	0.4	9.0			0.28	0.56	0.86	1.16	1.47	1.77	2.07	2.36	2.66	3.1
		4T	0.3	7.2			0.18	0.37	0.57	0.78	0.99	1.20	1.41	1.61	1.79	2
		5T	0.3	6.4			0.11	0.23	0.35	0.47	0.59	0.71	0.83	0.95	1.07	1.2
		6T	0.3	6.4			0.07	0.14	0.21	0.28	0.34	0.41	0.48	0.55	0.62	0.8
1-1/2"	40	FT	1.2	30.0	0.8	20	2.64	5.38	8.46	11.77	15.22	18.77	21.56	24.09	26.50	28
		1T	0.8	21.5			1.63	3.16	4.70	6.25	7.90	9.52	11.12	12.68	14.18	16
		2T	0.6	16.0			0.95	1.89	2.86	3.86	4.88	5.88	6.90	7.92	8.86	10.5
		3T	0.5	12.5			0.57	1.13	1.72	2.33	2.96	3.58	4.19	4.78	5.33	6
		4T	0.4	10.0			0.37	0.74	1.14	1.54	1.96	2.38	2.79	3.18	3.55	4
		5T	0.3	7.0			0.19	0.38	0.57	0.78	0.99	1.19	1.40	1.60	1.78	2.2
		6T	0.3	6.4			0.12	0.24	0.36	0.47	0.59	0.71	0.83	0.95	1.06	1.2
2"	50	FT	1.7	43.9	0.8	20	4.13	9.24	14.48	19.71	25.09	30.56	35.97	40.01	44.64	49
		1T	1.3	33.4			2.27	4.97	7.88	10.94	13.72	16.51	19.28	22.03	24.97	28
		2T	0.8	21.5			1.26	2.76	4.37	6.05	7.77	9.53	11.23	12.73	14.32	17
		3T	0.6	16.0			0.82	1.78	2.80	3.86	4.93	5.98	7.01	7.98	8.89	10
3"	80	FT	2.8	72.0	1.5	40	9.96	21.06	32.40	42.65	52.98	63.70	76.67	86.07	91.15	100
		1T	1.9	47.0			5.35	11.64	18.74	26.58	33.66	40.46	47.18	53.74	60.34	70
		2T	1.3	34.0			3.47	7.21	11.20	15.38	19.69	24.06	28.45	31.99	35.66	42
		3T	1.0	25.0			2.17	4.47	6.86	9.32	11.81	14.29	16.73	19.08	21.29	25
4"	100	FT	3.6	91.5	1.5	40	12.67	27.12	47.27	66.04	85.99	106.88	127.85	147.47	167.93	190
		1T	2.4	60.0			7.32	15.77	25.33	36.43	51.05	63.30	75.78	88.32	103.94	120
		2T	1.7	43.0			7.02	13.84	20.64	27.41	34.07	43.44	50.85	57.09	63.09	72
		3T	1.3	32.0			4.03	8.16	12.45	16.82	21.18	25.44	29.51	33.31	37.67	42

NOTE

cv: Valve flow coefficient
 FL: Liquid pressure recovery factor
 FT: Full Capacity
 2T: 2-Step reduction
 4T: 4-Step reduction
 6T: 6-Step reduction

1T: 1-Step reduction
 3T: 3-Step reduction
 5T: 5-Step reduction

AB Series Cv vs Travel (General Plug)

ANSI Class : 150# ~ 600#

Size : 2" ~ 16"

Flow Characteristic: LINEAR

Valve Travel [%]							10	20	30	40	50	60	70	80	90	100		
F _L							0.95	0.95	0.94	0.94	0.93	0.93	0.92	0.92	0.91	0.91		
Valve Size		Orifice Dia.			Travel		Rated Cv											
Inch	mm	Sign	Inch	mm	Inch	mm												
2	50	FC	2.5	64.5	1.6	40	8.1	16.1	24.1	32.2	40.2	48.2	56.3	64.3	72.3	82		
		1A					7.3	14.5	21.8	29.0	36.3	43.5	50.8	58.0	65.3	74		
		2A					4.3	8.6	12.9	17.3	21.6	25.9	30.2	34.5	38.8	44		
		3A					2.6	5.1	7.6	10.2	12.7	15.3	17.8	20.4	22.9	26		
3	80	FC	3.5	89.0	2	50	17.1	34.1	51.2	68.2	85.3	102.3	119.4	136.5	153.5	174		
		1A					10.2	20.4	30.6	40.8	51.0	61.2	71.4	81.6	91.7	104		
		2A					6.1	12.2	18.2	24.3	30.4	36.5	42.5	48.6	54.7	62		
		3A					3.9	7.8	11.8	15.7	19.6	23.5	27.4	31.4	35.3	40		
4	100	FC	4.4	111.5	2	50	27.5	54.9	82.4	109.8	137.3	164.7	192.1	219.6	247.0	280		
		1A					16.7	33.4	50.0	66.7	83.3	100.0	116.7	133.3	150.0	170		
		2A					9.8	19.6	29.4	39.2	49.0	58.8	68.6	78.4	88.2	100		
		3A					6.3	12.6	18.8	25.1	31.4	37.6	43.9	50.2	56.5	64		
6	150	FC	5.3	133.6	2.4	60	46.2	92.2	138.3	184.3	230.4	276.5	322.5	368.6	414.6	470		
		1A					27.9	55.7	83.6	111.4	139.2	167.0	194.9	222.7	250.5	284		
		2A					16.7	33.4	50.0	66.7	83.3	100.0	116.7	133.3	150.0	170		
		3A					9.8	19.6	29.4	39.2	49.0	58.8	68.6	78.4	88.2	100		
8	200	FC	6.9	175.5	2.8	70	79.5	158.9	238.3	317.7	397.1	476.4	555.8	635.2	714.6	810		
		1A					49.1	98.1	147.1	196.1	245.1	294.1	343.1	392.1	441.1	500		
		2A					31.4	62.8	94.1	125.5	156.9	188.2	219.6	250.9	282.3	320		
		3A					19.6	39.2	58.8	78.4	98.0	117.6	137.2	156.8	176.4	200		
10	250	FC	8.4	214.2	3.1	80	122.8	245.3	367.8	490.3	612.8	735.3	857.8	980.3	1102.8	1250		
		1A					74.6	149.1	223.6	298.1	372.6	447.0	521.5	596.0	670.5	760		
		2A					45.2	90.3	135.3	180.4	225.5	270.6	315.7	360.7	405.8	460		
		3A					27.5	54.9	82.4	109.8	137.3	164.7	192.1	219.6	247.0	280		
12	300	FC	10.4	264.8	3.9	120	177.7	355.1	532.5	709.9	887.3	1064.6	1242.0	1419.4	1596.8	1810		
		1A					108.0	215.8	323.6	431.4	539.2	647.0	754.8	862.6	970.4	1100		
		2A					66.8	133.4	200.1	266.7	333.3	400.0	466.6	533.3	599.9	680		
		3A					41.2	82.4	123.6	164.7	205.9	247.0	288.2	329.4	370.5	420		
14	350	FC	12.4	315.5	4.7	140	248.4	496.4	744.3	992.3	1240.2	1488.1	1736.1	1984.0	2232.0	2530		
		1A					150.9	302.1	453.1	604.0	754.9	905.8	1056.7	1207.7	1358.6	1540		
		2A					92.1	184.4	276.5	368.7	460.8	552.9	645.0	737.1	829.3	940		
		3A					56.9	113.8	170.6	227.5	284.3	341.2	398.0	454.8	511.7	580		
16	400	FC	14.1	357.7	5.5	160	290.1	580.8	870.8	1160.9	1451.0	1741.1	2031.2	2321.2	2611.3	2960		
		1A					174.5	349.2	523.7	698.1	872.6	1047.0	1221.4	1395.9	1570.3	1780		
		2A					105.9	211.9	317.7	423.6	529.4	635.3	741.1	846.9	952.8	1080		
		3A					64.7	129.5	194.2	258.9	323.5	388.2	452.9	517.6	582.3	660		

NOTE
 Cv: Valve flow coefficient
 FL: Liquid pressure recovery factor
 FC: Full Capacity 1A: 1-Step reduction
 2A: 2-Step reduction 3A: 3-Step reduction

AB Series Cv vs Travel (General Plug)

ANSI Class : 150# ~ 600#

Size: 2" ~ 16"

Flow Characteristic: EQ%

Valve Travel [%]							10	20	30	40	50	60	70	80	90	100	
F _L							0.95	0.95	0.95	0.94	0.94	0.94	0.93	0.92	0.92	0.92	0.90
Valve Size		Orifice Dia.			Travel		Rated Cv										
Inch	mm	Sign	Inch	mm	Inch	mm											
2	50	FC	2.5	64.5	1.6	40	2.3	3.3	4.9	8.4	15.2	25.1	41.0	57.8	68.4	76	
		1A					1.4	2.0	3.0	5.1	9.2	15.2	24.8	35.0	41.4	46	
		2A					0.8	1.2	1.8	3.1	5.6	9.2	15.1	21.3	25.2	28	
		3A					0.5	0.8	1.2	2.0	3.6	5.9	9.7	13.7	16.2	18	
3	80	FC	3.5	89.0	2	50	4.8	7.0	10.4	17.6	32.0	52.8	86.4	121.6	144.0	160	
		1A					2.9	4.3	6.4	10.8	19.6	32.3	52.9	74.5	88.2	98	
		2A					1.8	2.6	3.9	6.6	12.0	19.8	32.4	45.6	54.0	60	
		3A					1.1	1.6	2.3	4.0	7.2	11.9	19.4	27.4	32.4	36	
4	100	FC	4.4	111.5	2	50	7.7	11.3	16.6	28.2	51.2	84.5	138.2	194.6	230.4	256	
		1A					4.7	6.9	10.1	17.2	31.2	51.5	84.2	118.6	140.4	156	
		2A					2.8	4.1	6.1	10.3	18.8	31.0	50.8	71.4	84.6	94	
		3A					1.8	2.6	3.9	6.6	12.0	19.8	32.4	45.6	54.0	60	
6	150	FC	5.3	133.6	2.4	60	12.9	18.9	28.0	47.3	86.0	141.9	232.2	326.8	387.0	430	
		1A					7.8	11.4	16.9	28.6	52.0	85.8	140.4	197.6	234.0	260	
		2A					4.7	6.9	10.1	17.2	31.2	51.5	84.2	118.6	140.4	156	
		3A					2.9	4.2	6.2	10.6	19.2	31.7	51.8	73.0	86.4	96	
8	200	FC	6.9	175.5	2.8	70	22.2	32.6	48.1	81.4	148.0	244.2	399.6	562.4	666.0	740	
		1A					13.5	19.8	29.3	49.5	90.0	148.5	243.0	342.0	405.0	450	
		2A					8.1	11.9	17.6	29.7	54.0	89.1	145.8	205.2	243.0	270	
		3A					4.9	7.2	10.7	18.0	32.8	54.1	88.6	124.6	147.6	164	
10	250	FC	8.4	214.2	3.1	80	34.2	50.2	74.1	125.4	228.0	376.2	615.6	866.4	1026.0	1140	
		1A					20.4	29.9	44.2	74.8	136.0	224.4	367.2	516.8	612.0	680	
		2A					12.3	18.0	26.7	45.1	82.0	135.3	221.4	311.6	369.0	410	
		3A					7.5	11.0	16.3	27.5	50.0	82.5	135.0	190.0	225.0	250	
12	300	FC	10.4	264.8	3.9	120	49.5	72.6	107.3	181.5	330.0	544.5	891.0	1254.0	1485.0	1650	
		1A					30.0	44.0	65.0	110.0	200.0	330.0	540.0	760.0	900.0	1000	
		2A					19.2	28.2	41.6	70.4	128.0	211.2	345.6	486.4	576.0	640	
		3A					11.5	16.9	25.0	42.2	76.8	126.7	207.4	291.8	345.6	384	
14	350	FC	12.4	315.5	4.7	140	69.0	101.2	149.5	253.0	460.0	759.0	1242.0	1748.0	2070.0	2300	
		1A					42.0	61.6	91.0	154.0	280.0	462.0	756.0	1064.0	1260.0	1400	
		2A					25.2	37.0	54.6	92.4	168.0	277.2	453.6	638.4	756.0	840	
		3A					15.6	22.9	33.8	57.2	104.0	171.6	280.8	395.2	468.0	520	
16	400	FC	14.1	357.7	5.5	160	81.0	118.8	175.5	297.0	540.0	891.0	1458.0	2052.0	2430.0	2700	
		1A					49.2	72.2	106.6	180.4	328.0	541.2	885.6	1246.4	1476.0	1640	
		2A					29.4	43.1	63.7	107.8	196.0	323.4	529.2	744.8	882.0	980	
		3A					18.0	26.4	39.0	66.0	120.0	198.0	324.0	456.0	540.0	600	

NOTE

cv : Valve flow coefficient
 FL : Liquid pressure recovery factor
 FC: Full Capacity
 2A: 2-Step reduction

1A: 1-Step reduction
 3A: 3-Step reduction

AB Series Cv vs Travel (Tendril 1)

ANSI Class : 150# ~ 600#

Size: 2" ~ 16"

Flow Characteristic: LINEAR

Valve Travel [%]							10	20	30	40	50	60	70	80	90	100	
F _L							0.84	0.84	0.85	0.85	0.85	0.86	0.87	0.87	0.95	0.86	
Valve Size		Orifice Dia.			Travel		Rated Cv										
Inch	mm	Sign	Inch	mm	Inch	mm											
2	50	FC	2.5	64.5	1.6	40	3.0	11.8	19.7	26.6	33.2	39.0	43.8	47.7	50.8	52	
		1A					1.9	7.7	13.0	17.7	22.4	26.8	31.0	34.8	38.3	40	
		2A					1.2	4.8	8.1	11.2	14.3	17.2	20.1	22.8	25.4	27	
		3A					0.4	1.7	2.9	4.0	5.2	6.3	7.4	8.5	9.6	10	
3	80	FC	3.5	89.0	2	50	7.5	23.0	36.9	49.9	61.9	73.2	82.9	91.2	98.0	102	
		1A					4.7	14.6	23.7	32.4	40.6	48.8	56.4	63.6	70.4	75	
		2A					2.4	7.6	12.4	17.1	21.7	26.2	30.5	34.8	38.9	40	
		3A					1.2	3.9	6.4	8.9	11.3	13.8	16.1	18.4	20.7	21	
4	100	FC	4.4	111.5	2	50	8.5	32.6	55.1	75.9	95.6	113.8	130.5	144.6	156.2	160	
		1A					5.3	20.4	34.8	48.3	61.5	74.1	86.7	98.5	109.6	120	
		2A					2.9	11.3	19.5	27.3	34.9	42.4	49.9	57.1	64.2	70	
		3A					1.9	7.6	13.2	18.5	23.8	28.9	34.2	39.2	44.1	46	
6	150	FC	5.3	133.6	2.4	60	13.8	54.4	95.1	134.3	170.9	204.3	234.1	259.9	281.9	290	
		1A					9.0	35.2	61.8	88.2	114.1	139.2	163.1	185.7	206.9	220	
		2A					4.9	18.9	33.1	47.3	61.6	75.9	90.1	104.1	117.9	130	
		3A					2.9	10.8	18.8	26.9	35.0	43.2	51.4	59.5	67.7	75	
8	200	FC	6.9	175.5	2.8	70	19.7	87.1	152.3	213.7	271.5	323.2	368.8	409.4	444.2	460	
		1A					12.7	56.0	98.8	140.5	181.6	220.5	257.3	292.4	324.9	340	
		2A					6.4	28.0	49.5	70.8	92.4	113.6	134.4	155.2	175.5	195	
		3A					3.6	15.6	27.5	39.3	51.4	63.3	75.1	87.1	99.0	105	
10	250	FC	8.4	214.2	3.1	80	39.7	122.6	206.9	287.7	361.2	430.8	493.5	548.0	597.7	630	
		1A					25.7	78.3	132.7	186.4	237.5	288.4	337.1	382.2	426.0	460	
		2A					14.2	41.5	69.9	98.4	126.0	154.4	182.4	209.4	236.8	255	
		3A					8.4	23.2	38.6	54.1	69.1	84.6	100.2	115.3	130.8	140	
12	300	FC	10.4	264.8	3.9	120	76.8	216.1	351.6	478.6	594.1	696.7	786.2	863.1	928.4	980	
		1A					48.9	136.8	224.6	310.8	394.0	473.3	548.1	617.8	682.3	735	
		2A					25.2	68.8	112.8	156.8	200.8	244.4	287.5	330.0	371.7	405	
		3A					15.4	40.7	66.1	91.7	117.4	143.1	168.8	194.5	220.0	240	
14	350	FC	12.4	315.5	4.7	140	89.2	275.6	460.6	634.1	789.1	929.1	1050.3	1151.4	1237.4	1300	
		1A					56.5	174.0	293.5	410.7	521.9	629.9	731.6	824.7	912.3	985	
		2A					29.7	90.1	152.1	214.2	274.8	336.1	396.5	454.9	513.1	565	
		3A					16.4	48.4	81.3	114.3	146.8	179.9	212.9	245.3	278.2	310	
16	400	FC	14.1	357.7	5.5	160	121.6	332.6	546.9	756.9	949.0	1121.7	1274.6	1402.5	1508.5	1580	
		1A					73.6	198.0	326.6	458.4	586.9	712.2	834.3	948.3	1055.2	1145	
		2A					41.5	108.3	177.2	248.6	319.8	391.4	464.1	535.3	605.7	670	
		3A					26.9	68.0	110.1	153.6	197.1	241.1	286.2	330.8	375.6	415	

AB Series Cv vs Travel (Tendril 1)

ANSI Class : 150# ~ 600#

Size: 2" ~ 16"

Flow Characteristic: EQ%

Valve Travel [%]							10	20	30	40	50	60	70	80	90	100
F _L							0.84	0.84	0.84	0.84	0.84	0.85	0.85	0.86	0.95	0.88
Valve Size		Orifice Dia.			Travel		Rated Cv									
Inch	mm	Sign	Inch	mm	Inch	mm										
2	50	FC	2.5	64.5	1.6	40	0.4	2.4	4.4	8.1	13.7	20.5	28.3	36.4	44.1	50
		1A					0.4	2.4	4.2	5.9	9.5	14.6	20.4	25.7	30.7	35
		2A					0.2	1.0	2.3	4.0	6.2	8.9	11.9	14.8	17.7	20
		3A					0.2	1.0	2.2	3.4	4.5	5.7	6.8	7.9	9.0	10
3	80	FC	3.5	89.0	2	50	0.7	2.7	6.3	12.5	20.9	31.5	43.6	57.0	71.1	82
		1A					0.7	2.7	4.7	8.5	14.8	23.6	33.3	42.5	51.3	58
		2A					0.7	2.7	4.7	8.5	13.3	18.1	22.6	27.1	31.3	35
		3A					0.3	1.4	3.1	5.5	8.0	10.5	12.9	15.3	17.6	20
4	100	FC	4.4	111.5	2	50	1.0	5.2	9.5	17.1	30.3	48.2	71.3	95.5	117.5	135
		1A					0.5	2.6	6.3	13.0	22.3	34.2	48.8	65.1	82.1	95
		2A					0.5	2.6	4.8	8.7	15.6	24.6	33.8	42.5	51.1	58
		3A					0.5	2.6	4.8	8.5	12.6	16.6	20.7	24.6	28.5	32
6	150	FC	5.3	133.6	2.4	60	1.6	7.5	16.2	33.1	58.4	91.7	131.8	172.1	208.6	235
		1A					1.6	7.5	13.4	22.2	39.2	64.5	92.9	120.7	147.3	170
		2A					0.9	3.8	6.8	11.1	19.5	32.0	48.7	67.1	85.4	100
		3A					0.9	3.8	6.8	11.1	18.8	26.9	35.0	43.2	51.4	58
8	200	FC	6.9	175.5	2.8	70	1.5	12.8	35.3	68.6	113.2	167.1	227.7	288.0	341.3	370
		1A					1.5	8.5	21.5	45.3	80.7	122.9	163.9	204.1	242.0	265
		2A					0.8	4.3	10.8	22.6	40.3	63.6	91.9	122.8	152.7	170
		3A					0.8	4.3	8.0	15.1	28.0	44.6	61.2	78.0	94.6	105
10	250	FC	8.4	214.2	3.1	80	4.2	19.1	48.4	91.6	147.0	216.6	295.8	370.8	441.5	500
		1A					4.2	12.2	31.1	63.9	109.2	165.6	221.2	273.6	325.3	370
		2A					4.2	12.2	21.5	43.8	73.9	105.0	136.0	166.0	196.5	225
		3A					2.9	6.8	11.5	22.6	39.3	57.3	75.4	93.0	111.1	125
12	300	FC	10.4	264.8	3.9	120	7.4	26.7	75.3	153.7	260.7	391.7	527.8	648.9	754.0	840
		1A					7.4	18.8	52.7	116.3	202.8	289.5	373.5	453.9	529.8	600
		2A					4.5	10.2	27.1	58.6	104.8	156.2	207.5	258.3	308.3	355
		3A					4.5	10.2	27.1	52.5	78.0	103.7	129.4	155.1	180.7	205
14	350	FC	12.4	315.5	4.7	140	6.7	30.7	93.6	195.6	332.7	504.5	687.7	849.2	992.0	1110
		1A					6.7	21.0	67.3	152.6	264.7	378.6	489.2	593.3	693.8	785
		2A					4.0	11.1	34.1	76.5	137.3	207.6	277.7	345.7	414.0	480
		3A					4.0	11.1	34.1	70.6	107.0	144.2	181.4	217.9	255.1	290
16	400	FC	14.1	357.7	5.5	160	9.4	44.5	125.3	258.1	439.8	664.3	890.8	1090.8	1263.7	1400
		1A					9.4	30.8	94.0	207.6	349.8	493.0	635.9	771.9	901.1	1020
		2A					6.1	16.7	47.8	102.8	180.1	263.7	349.8	434.9	519.6	600
		3A					6.1	16.7	47.8	90.1	132.6	175.8	220.2	264.5	309.0	350

NOTE
 cv : Valve flow coefficient
 FL : Liquid pressure recovery factor
 FC : Full Capacity
 1A : 1-Step reduction
 2A : 2-Step reduction
 3A : 3-Step reduction

AB Series Cv vs Travel (Tendril 1)

ANSI Class : 150# ~ 600#

Size: 2" ~ 16"

Flow Characteristic :EQ%

Valve Travel [%]							10	20	30	40	50	60	70	80	90	100	
F _L							0.84	0.84	0.84	0.84	0.84	0.85	0.85	0.85	0.86	0.95	0.88
Valve Size		Orifice Dia.			Travel		Rated Cv										
Inch	mm	Sign	Inch	mm	Inch	mm											
2	50	FC	2.5	64.5	1.6	40	0.4	2.4	4.4	8.1	13.7	20.5	28.3	36.4	44.1	50	
		1A					0.4	2.4	4.2	5.9	9.5	14.6	20.4	25.7	30.7	35	
		2A					0.2	1.0	2.3	4.0	6.2	8.9	11.9	14.8	17.7	20	
		3A					0.2	1.0	2.2	3.4	4.5	5.7	6.8	7.9	9.0	10	
3	80	FC	3.5	89.0	2	50	0.7	2.7	6.3	12.5	20.9	31.5	43.6	57.0	71.1	82	
		1A					0.7	2.7	4.7	8.5	14.8	23.6	33.3	42.5	51.3	58	
		2A					0.7	2.7	4.7	8.5	13.3	18.1	22.6	27.1	31.3	35	
		3A					0.3	1.4	3.1	5.5	8.0	10.5	12.9	15.3	17.6	20	
4	100	FC	4.4	111.5	2	50	1.0	5.2	9.5	17.1	30.3	48.2	71.3	95.5	117.5	135	
		1A					0.5	2.6	6.3	13.0	22.3	34.2	48.8	65.1	82.1	95	
		2A					0.5	2.6	4.8	8.7	15.6	24.6	33.8	42.5	51.1	58	
		3A					0.5	2.6	4.8	8.5	12.6	16.6	20.7	24.6	28.5	32	
6	150	FC	5.3	133.6	2.4	60	1.6	7.5	16.2	33.1	58.4	91.7	131.8	172.1	208.6	235	
		1A					1.6	7.5	13.4	22.2	39.2	64.5	92.9	120.7	147.3	170	
		2A					0.9	3.8	6.8	11.1	19.5	32.0	48.7	67.1	85.4	100	
		3A					0.9	3.8	6.8	11.1	18.8	26.9	35.0	43.2	51.4	58	
8	200	FC	6.9	175.5	2.8	70	1.5	12.8	35.3	68.6	113.2	167.1	227.7	288.0	341.3	370	
		1A					1.5	8.5	21.5	45.3	80.7	122.9	163.9	204.1	242.0	265	
		2A					0.8	4.3	10.8	22.6	40.3	63.6	91.9	122.8	152.7	170	
		3A					0.8	4.3	8.0	15.1	28.0	44.6	61.2	78.0	94.6	105	
10	250	FC	8.4	214.2	3.1	80	4.2	19.1	48.4	91.6	147.0	216.6	295.8	370.8	441.5	500	
		1A					4.2	12.2	31.1	63.9	109.2	165.6	221.2	273.6	325.3	370	
		2A					4.2	12.2	21.5	43.8	73.9	105.0	136.0	166.0	196.5	225	
		3A					2.9	6.8	11.5	22.6	39.3	57.3	75.4	93.0	111.1	125	
12	300	FC	10.4	264.8	3.9	120	7.4	26.7	75.3	153.7	260.7	391.7	527.8	648.9	754.0	840	
		1A					7.4	18.8	52.7	116.3	202.8	289.5	373.5	453.9	529.8	600	
		2A					4.5	10.2	27.1	58.6	104.8	156.2	207.5	258.3	308.3	355	
		3A					4.5	10.2	27.1	52.5	78.0	103.7	129.4	155.1	180.7	205	
14	350	FC	12.4	315.5	4.7	140	6.7	30.7	93.6	195.6	332.7	504.5	687.7	849.2	992.0	1110	
		1A					6.7	21.0	67.3	152.6	264.7	378.6	489.2	593.3	693.8	785	
		2A					4.0	11.1	34.1	76.5	137.3	207.6	277.7	345.7	414.0	480	
		3A					4.0	11.1	34.1	70.6	107.0	144.2	181.4	217.9	255.1	290	
16	400	FC	14.1	357.7	5.5	160	9.4	44.5	125.3	258.1	439.8	664.3	890.8	1090.8	1263.7	1400	
		1A					9.4	30.8	94.0	207.6	349.8	493.0	635.9	771.9	901.1	1020	
		2A					6.1	16.7	47.8	102.8	180.1	263.7	349.8	434.9	519.6	600	
		3A					6.1	16.7	47.8	90.1	132.6	175.8	220.2	264.5	309.0	350	

NOTE
 cv : Valve flow coefficient
 FL : Liquid pressure recovery factor
 FC : Full Capacity
 1A : 1-Step reduction
 2A : 2-Step reduction
 3A : 3-Step reduction

A series, Valve dimensions and weights

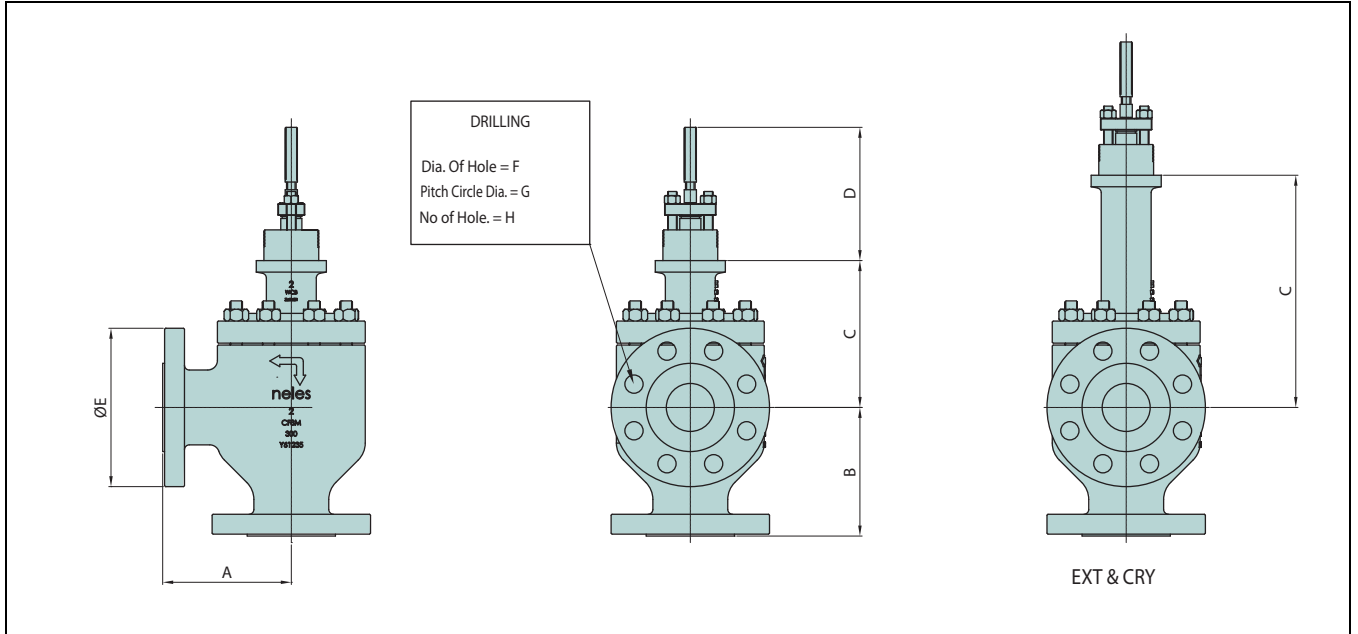

150 # / 300 # / 600 #

Dimension (mm)	A			B			C			D	E			F			G			H			Weight(kg) (Approximate)		
	150#	300#	600#	150#	300#	600#	STD	EXT	CRY	COMMON	150#	300#	600#	150#	300#	600#	150#	300#	600#	150#	300#	600#	150#	300#	600#
25	92	99	105	92	99	105	142	250	400	110	110	125	125	15.9	19.1	19.1	79.4	88.9	88.9	4	4	4	14	15	23
40	111	118	125	111	118	125	161	269	419	110	125	155	155	15.9	22.2	22.2	98.4	114.3	114.3	4	4	4	22	23	27
50	127	133	143	127	133	143	178	333	458	110	150	165	165	19.1	19.1	19.1	120.7	127	127	4	8	8	25	27	32
80	149	159	168	149	159	168	222	395	545	115	190	210	210	19.1	22.2	22.2	152.4	168.3	168.3	4	8	8	65	67	72
100	176	184	197	176	184	197	248	402	552	140	230	255	275	19.1	22.2	25.4	190.5	200	215.9	8	8	8	100	103	112
150	226	236	254	226	236	254	340	467	642	150	280	320	355	22.2	22.2	28.6	241.3	269.9	292.1	8	12	12	185	195	240
200	272	284	305	272	284	305	451	557	732	150	345	380	420	22.2	25.4	31.8	298.5	330.2	349.2	8	12	12	363	385	443
250	337	354	376	337	354	376	488	670	870	150	405	445	510	25.4	28.6	34.9	362	387.4	431.8	12	16	16	552	595	681
300	369	388	410	369	388	410	543	716	916	150	485	520	560	25.4	31.8	34.9	431.8	450.8	489	12	16	20	905	955	1020
350	445	464	486	445	464	486	616	846	1046	210	535	585	605	28.6	31.8	38.1	476.3	514.4	527	12	20	20	1170	1230	1311
400	508	529	554	508	529	554	692	909	1109	220	595	650	685	28.6	34.9	41.3	539.8	571.5	603.2	16	20	20	1380	1460	1587

Dimension (inch)	A			B			C			D	E			F			G			H			Weight(lbs) (Approximate)		
	150#	300#	600#	150#	300#	600#	STD	EXT	CRY	COMMON	150#	300#	600#	150#	300#	600#	150#	300#	600#	150#	300#	600#	150#	300#	600#
1"	3.6	3.9	4.1	3.6	3.9	4.1	5.6	9.8	15.7	4.3	4.3	4.9	4.9	0.6	0.8	0.8	3.1	3.5	3.5	4	4	4	30.9	33.1	50.7
1-1/2"	4.4	4.6	4.9	4.4	4.6	4.9	6.3	10.6	16.5	4.3	4.9	6.1	6.1	0.6	0.9	0.9	3.9	4.5	4.5	4	4	4	48.5	50.7	59.5
2"	5	5.2	5.6	5	5.2	5.6	7	13.1	18	4.3	5.9	6.5	6.5	0.8	0.8	0.8	4.8	5	5	4	8	8	55.1	59.5	70.5
3"	5.9	6.3	6.6	5.9	6.3	6.6	8.7	15.6	21.5	4.5	7.5	8.3	8.3	0.8	0.9	0.9	6	6.6	6.6	4	8	8	143.3	147.7	158.7
4"	6.9	7.2	7.8	6.9	7.2	7.8	9.8	15.8	21.7	5.5	9.1	10	10.8	0.8	0.9	1	7.5	7.9	8.5	8	8	8	220.5	227.1	246.9
6"	8.9	9.3	10	8.9	9.3	10	13.4	18.4	25.7	5.9	11	12.6	14	0.9	0.9	1.1	9.5	10.6	11.5	8	12	12	407.9	429.9	529.1
8"	10.7	11.2	12	10.7	11.2	12	17.8	21.9	28.8	5.9	13.6	15	16.5	0.9	1	1.3	11.8	13	13.7	8	12	12	800.3	848.8	976.6
10"	13.3	13.9	14.8	13.3	13.9	14.8	19.2	26.4	34.3	5.9	15.9	17.5	20.1	1	1.1	1.4	14.3	15.3	17	12	16	16	1217	1311.8	1501.3
12"	15	15.3	16.1	14.5	15.3	16.1	21.4	28.2	36.1	5.9	19.1	20.5	22	1	1.3	1.4	17	17.7	19.3	12	16	20	1995.2	2105.4	2248.7
14"	18	18.3	19.1	17.5	18.3	19.1	24.3	33.3	41.2	8.3	21.1	23	23.8	1.1	1.3	1.5	18.8	20.3	20.7	12	20	20	2579.4	2711.7	2890.3
16"	20	20.8	21.8	20	20.8	21.8	27.2	35.8	43.7	8.7	23.4	25.6	27	1.1	1.4	1.6	21.3	22.5	23.7	16	20	20	3042.4	3218.7	3498.7

900 #/ 1500 #

Dimension (mm)	A		B		C		D	E		F		G		H		Weight (kg) (Approximate)	
	900#	1500#	900#	1500#	STD	EXT	COMMON	900#	1500#	900#	1500#	900#	1500#	900#	1500#	900#	1500#
25	146	146	146	146	229	330	110	150	150	25.4	25.4	101.6	101.6	4	4	44	46
40	167	167	167	167	278	380	110	180	180	28.6	28.6	123.8	123.8	4	4	63	63
50	188	188	188	188	300	400	110	215	215	25.4	25.4	165.1	165.1	8	8	67	67
80	221	230	221	230	330	430	115	240	265	25.4	31.8	190.5	203.2	8	8	150	163
100	256	265	256	265	350	450	140	290	310	31.8	34.9	235	241.3	8	8	244	255
150	357	384	357	384	393	500	150	380	395	31.8	38.1	317.5	317.5	12	12	530	540
200	457	486	457	486	480	600	150	470	485	38.1	44.5	393.7	393.7	12	12	698	821
250	496	534	496	534	518	650	150	545	585	38.1	50.8	469.9	482.6	16	12	955	1137
300	565	610	565	610	680	800	150	610	675	38.1	54	533.4	571.5	20	16	1180	1240
350	629	629	629	629	770	920	210	640	750	41.3	60.3	558.8	635	20	16	1387	1477
400	711	711	711	711	850	1050	220	705	825	44.5	66.7	616	704.8	20	16	1601	1721

Dimension (inch)	A		B		C		D	E		F		G		H		Weight (lbs) (Approximate)	
	900#	1500#	900#	1500#	STD	EXT	COMMON	900#	1500#	900#	1500#	900#	1500#	900#	1500#	900#	1500#
1"	5.7	5.7	5.7	5.7	9	13	4.3	5.9	5.9	1	1	4	4	4	4	97	101.4
1-1/2"	6.6	6.6	6.6	6.6	11	15	4.3	7.1	7.1	1.1	1.1	4.9	4.9	4	4	138.9	138.9
2"	7.4	7.4	7.4	7.4	12	16	4.3	8.5	8.5	1	1	6.5	6.5	8	8	147.7	147.7
3"	8.7	9.1	8.7	9.1	13	17	4.5	9.4	10.4	1	1.3	7.5	8	8	8	330.7	359.4
4"	10.1	10.4	10.1	10.4	14	18	5.5	11.4	12.2	1.3	1.4	9.3	9.5	8	8	537.9	562.2
6"	14.1	15.1	14.1	15.1	15	20	5.9	15	15.6	1.3	1.5	12.5	12.5	12	12	1168.4	1190.5
8"	18	19.1	18	19.1	19	24	5.9	18.5	19.1	1.5	1.8	15.5	15.5	12	12	1538.8	1810
10"	20	21	19.5	21	20	26	5.9	21.5	23	1.5	2	18.5	19	16	12	2105.4	2506.7
12"	22.2	24	22.2	24	27	31	5.9	24	26.6	1.5	2.1	21	22.5	20	16	2601.5	2733.7
14"	24.8	24.8	24.8	24.8	30	36	8.3	25.2	29.5	1.6	2.4	22	25	20	16	3057.8	3256.2
16"	28	28	28	28	33	41	8.7	27.8	32.5	1.8	2.6	24.3	27.7	20	16	3529.6	3794.2

* Larger sizes and ASME class 2500 & 4500 ratings are available, please contact Metso.

HOW TO ORDER

Angle Unbalanced, Top Guided Type, Series AU

1.	2.	3.	4.	5.	6.	7.	8.	9.	10.	11.	12.	13.	14.	15.	16.	17.	18.	19.	20.	21.	22.
AU	01	C	W	A	J2	B	P1	X	BC	S1	R1	X	S	G	X	S	A	X	A	E	FC

VALVE CONSTRUCTIONS

1.	VALVE SERIES
AU	Angle Unbalanced, Top guided type

2.	BODY SIZE		
0H	0.5" / DN 15	3Q	0.75" / DN 20
01	1" / DN 25	1H	1.5" / DN 40
02	2" / DN 50	03	3" / DN 80
04	4" / DN 100	06	6" / DN 150
Y	Special		

3.	PRESSURE RATING			
C	ASME class 150	D	ASME class 300	
F	ASME class 600	G	ASME class 900	
H	ASME class 1500	I	ASME class 2500	
Y	Special			

4.	END CONNECTION
W	Flanged RF, ASME B16.5
Z	Ring joint flange, ASME B16.5
V	Socket welding, ASME B16.11
Q	Butt welding, ASME B16.25
Y	Special

5.	BONNET CONSTRUCTION	
	Bonnet Type	Actuator Connection
A	General	Applicable for VD_25/29/37
B	General	Applicable for VD_48/55
E	Extension	Applicable for VD_25/29/37
F	Extension	Applicable for VD_48/55
P	Cryogenic	Applicable for VD_25/29/37
Q	Cryogenic	Applicable for VD_48/55
J	Bellows Seals	Applicable for VD_25/29/37
K	Bellows Seals	Applicable for VD_48/55
Y	Special	Special

6.	BODY MATERIAL
J2	A216 gr. WCB
S6	A351 gr. CF8M
S1	A351 gr. CF3M
YY	Special

- Bonnet material is equivalent to Body material.

7.	MODEL CODE
B	Model B

TRIM CONSTRUCTIONS

8.	PLUG MATERIAL	
	Material	Description
P1	410 SS	General for carbon steel valve
T6	316 SS	General for stainless steel valve
VM	Alloy 6	Use for small Cv and Micro trim
S1	316L SS	
YY	Special	Special materials

9.	PLUG APPLICATION
X	Not applicable
A	Cobalt based alloy
Y	Special

10.	STEM MATERIAL	
	Material	Description
BC	630 SS + HCr	General for carbon steel valve
TC	316 SS + HCr	General for stainless steel valve
FC	316L SS + HCr	
YY	Special	Special materials

11.	SEAT TYPE
S1	Single metal seat
T1	Single soft seat
YY	Special

12.	SEAT / RETAINER MATERIAL		
	Seat	Retainer	Guide Bushing
R1	410 SS	CB7Cu-1 / 630 SS	AISI 440C
T6	316 SS	CF8M / 316 SS	AISI 316 + Alloy 6
V6	Alloy 6	CF8M / 316 SS	AISI 316 + Alloy 6
R2	420J2 SS	CB7Cu-1 / 630 SS	AISI 440C
R3	316L SS	316L SS	AISI 316 + Alloy 6
YY	Special	Special	Special

- AISI 410 is general for carbon steel valve.

- AISI 316 is general for carbon steel valve.

13.	SEAT APPLICATION
X	Not applicable
A	Cobalt based alloy
P	Insert PTFE
Q	Insert PTFE + Cobalt based alloy
Y	Special

OTHERS

14.	PACKING / BELLOWS TYPE
S	General packing
E	Low emission, Live loaded
C	Bellows Seal (316L SS, Formed)
Y	Special

18.	STUD / NUT MATERIAL
A	A193 gr. B7 / A194 gr. 2H
B	A193 gr. B8 / A194 gr. 8
K	A320 gr. B8M cl. 2 / A194 gr. 8M
H	A193 gr. B16 / A194 gr. 4
Y	Special

15.	PACKING MATERIAL
G	PTFE + Carbon fiber
F	Graphite
T	PTFE V-Ring
H	Hi-Graphite
Y	Special

19.	OPTIONS
X	Not applicable
E	Anti-erosion
L	Lub. & Isol. valve
W	Water seal
Y	Special

16.	SEAL RING MATERIAL
X	Not applicable

17.	GASKET MATERIAL
S	S/W gasket type, 316 SS + Graphite for standard
H	S/W gasket type, 316 SS + Graphite for high temp.
L	S/W gasket type, 316 SS + PTFE
Y	Special

* Face to face length according to ISA 75.08
 * The body, bonnet, trim materials are subject to change as equivalent depending on detail design.
 * See 'NelesGlobe Type code Instruction' for further options and explanations.

TRIM TYPE & RATED Cv

20.	TRIM TYPE	21.	TRIM CHARACTERISTIC	22.	RATED Cv													
					Sign	Description	Body Size and Stroke											
							0.5" Str.	0.75" Str.	1" Str.	1.5" Str.	2" Str.	3" Str.	4" Str.	6" Str.				
A	General plug	L	Linear	FC	General / Full capacity	7 (20)	9 (20)	13.5 (20)	28 (20)	49 (20)	100 (40)	190 (40)	295 (60)					
					1A	General / 1-Step reduction	4 (20)	5.5 (20)	8.5 (20)	16 (20)	28 (20)	70 (40)	120 (40)	165 (60)				
					2A	General / 2-Step reduction	2.3 (20)	3 (20)	5.4 (20)	10.5 (20)	17 (20)	42 (40)	72 (40)	85 (60)				
					3A	General / 3-Step reduction	1.5 (20)	2 (20)	3.1 (20)	6 (20)	10 (20)	25 (40)	42 (40)	50 (60)				
					4A	General / 4-Step reduction	0.8 (20)	1.2 (20)	2 (20)	4 (20)								
					5A	General / 5-Step reduction	0.5 (20)	0.7 (20)	1.2 (20)	2.2 (20)								
					6A	General / 6-Step reduction	0.3 (20)	0.4 (20)	0.8 (20)	1.2 (20)								
					FT	Tendril / Full capacity	7 (20)	9 (20)	13.5 (20)	28 (20)	49 (20)	100 (40)	190 (40)	IQI (60)				
					1T	Tendril / 1-Step reduction	4 (20)	5.5 (20)	8.5 (20)	16 (20)	28 (20)	70 (40)	120 (40)	IQI (60)				
					2T	Tendril / 2-Step reduction	2.3 (20)	3 (20)	5.4 (20)	10.5 (20)	17 (20)	42 (40)	72 (40)	IQI (60)				
					3T	Tendril / 3-Step reduction	1.5 (20)	2 (20)	3.1 (20)	6 (20)	10 (20)	25 (40)	42 (40)	IQI (60)				
					4T	Tendril / 4-Step reduction	0.8 (20)	1.2 (20)	2 (20)	4 (20)								
					5T	Tendril / 5-Step reduction	0.5 (20)	0.7 (20)	1.2 (20)	2.2 (20)								
					6T	Tendril / 6-Step reduction	0.3 (20)	0.4 (20)	0.8 (20)	1.2 (20)								
C	Micro plug	L	Linear	FC	General / Full capacity	0.1 (20)	0.1 (20)	0.1 (20)										
					1A	General / 1-Step reduction	0.06 (20)	0.06 (20)	0.06 (20)									
					2A	General / 2-Step reduction	0.03 (20)	0.03 (20)	0.03 (20)									
					3A	General / 3-Step reduction	0.01 (20)	0.01 (20)	0.01 (20)									
					4A	General / 4-Step reduction	0.006 (20)	0.006 (20)	0.006 (20)									
5A	General / 5-Step reduction	0.003 (20)	0.003 (20)	0.003 (20)														
Y	Special	Y	Special	YY	Special	Contact Metso for Cv details												

- Rated Cv is different depending on trim type and characteristic.- Str. : valve stroke length(mm). It should be matched with actuator stroke length.

HOW TO ORDER

Angle Balanced, Cage Guided Type, Series AB

1.	2.	3.	4.	5.	6.	7.	8.	9.	10.	11.	12.	13.	14.	15.	16.	17.	18.	19.	20.	21.	22.
AB	03	C	W	A	J2	B	P1	X	BC	S1	R1	X	S	F	G	S	A	X	A	E	FC

VALVE CONSTRUCTIONS

1.	VALVE SERIES
AB	Angle Balanced, Cage guided type

2.	BODY SIZE		
02	2" / DN 50	03	3" / DN 80
04	4" / DN 100	06	6" / DN 150
08	8" / DN 200	10	10" / DN 250
12	12" / DN 300	14	14" / DN 350
16	16" / DN 400	18	18" / DN 450
20	20" / DN 500	24	24" / DN 600
YY	Special		

3.	PRESSURE RATING		
C	ASME class 150	D	ASME class 300
F	ASME class 600	G	ASME class 900
H	ASME class 1500	I	ASME class 2500
Y	Special		

4.	END CONNECTION
W	Flanged RF, ASME B16.5
Z	Ring joint flange, ASME B16.5
V	Socket welding, ASME B16.11
Q	Butt welding, ASME B16.25
Y	Special

5.	BONNET CONSTRUCTION	
	Bonnet Type	Actuator Connection
A	General	Applicable for VD_25/29/37
B	General	Applicable for VD_48/55
C	General	Applicable for VC_30, VB_32
D	General	Applicable for VC/VB_40/50/60/70
E	Extension	Applicable for VD_25/29/37
F	Extension	Applicable for VD_48/55
G	Extension	Applicable for VC_30, VB_32
H	Extension	Applicable for VC/VB_40/50/60/70
P	Cryogenic	Applicable for VD_25/29/37
Q	Cryogenic	Applicable for VD_48/55
R	Cryogenic	Applicable for VC_30, VB_32
S	Cryogenic	Applicable for VC/VB_40/50/60/70
Y	Special	Special

6.	BODY MATERIAL
J2	A216 gr. WCB
S6	A351 gr. CF8M
S1	A351 gr. CF3M
YY	Special

- Bonnet material is equivalent to Body material.

7.	MODEL CODE
B	Model B

TRIM CONSTRUCTIONS

8.	PLUG MATERIAL	
	Material	Description
P1	CA15	General for carbon steel valve
T6	CF8M	General for stainless steel valve
S1	CF3M	
YY	Special	Special materials

9.	PLUG APPLICATION
X	Not applicable
A	Cobalt based alloy
Y	Special

10.	STEM MATERIAL	
	Material	Description
BC	630 SS + HCr	General for carbon steel valve
TC	316 SS + HCr	General for stainless steel valve
FC	316L SS + HCr	
YY	Special	Special materials

11.	SEAT TYPE
S1	Single metal seat
T1	Single soft seat
YY	Special

12.	SEAT / RETAINER MATERIAL		
	Seat	Retainer	Guide Bushing
R1	CA15	CB7Cu-1 / 630 SS + HCr	CB7Cu-1 + HCr
T6	CF8M	CF8M / 316 SS + HCr	CF8M + HCr
R3	CF3M	CF3M / 316L SS + HCr	CF3M + HCr
YY	Special	Special	Special

- CA15 / AISI 410 is general for carbon steel valve.
- CF8M / AISI 316 is general for stainless steel valve.

13.	SEAT APPLICATION
X	Not applicable
A	Cobalt based alloy
P	Insert PTFE
Q	Insert PTFE + Cobalt based alloy
Y	Special

OTHERS

14.	PACKING / BELLOWS TYPE
S	General packing
E	Low emission, Live loaded
C	Bellows Seal (316L SS, Formed)
Y	Special

17.	GASKET MATERIAL
S	S/W gasket type, 316 SS +Go to Previous Page
L	S/W gasket type, 316 SS + PTFE
H	S/W gasket type, 316 SS + Graphite for high temp.
Y	Special

15.	PACKING MATERIAL
G	PTFE + Carbon fiber
F	Graphite
T	PTFE V-Ring
H	Hi-Graphite
Y	Special

18.	STUD / NUT MATERIAL
A	A193 gr. B7 / A194 gr. 2H
B	A193 gr. B8 / A194 gr. 8
K	A320 gr. B8M cl. 2 / A194 gr. 8M
H	A193 gr. B16 / A194 gr. 4
Y	Special

16.	SEAL RING MATERIAL
G	PTFE + Graphite
T	PTFE
H	PTFE + Graphite + Carbon
Y	Special

19.	OPTIONS
X	Not applicable
E	Anti-erosion
L	Lub. & Isol. valve
W	Water seal
Y	Special

* Face to face length according to ISA 75.08
 * The body, bonnet, trim materials are subject to change as equivalent depending on detail design.
 * See 'NelesGlobe Type code Instruction' for further options and explanations.

TRIM TYPE & RATED Cv

20. Sign	TRIM TYPE	21. Sign	TRIM CHARACTERISTIC	22. Sign	Description	RATED Cv															
						Body Size and Stroke															
						2" Str.	3" Str.	4" Str.	6" Str.	8" Str.	10" Str.	12" Str.	14" Str.	16" Str.							
A P	General plug Pilot balanced plug	L	Linear	FC	General / Full capacity	82 (40)	174 (50)	280 (50)	470 (60)	810 (70)	1250 (80)	1810 (120)	2530 (140)	2960 (160)							
				1A	General / 1-Step reduction	74 (40)	104 (50)	170 (50)	284 (60)	500 (70)	760 (80)	1100 (120)	1540 (140)	1780 (160)							
				2A	General / 2-Step reduction	44 (40)	62 (50)	100 (50)	170 (60)	320 (70)	460 (80)	680 (120)	940 (140)	1080 (160)							
				3A	General / 3-Step reduction	26 (40)	40 (50)	64 (50)	100 (60)	200 (70)	280 (80)	420 (120)	580 (140)	660 (160)							
				FT	Tendril 1 / Full capacity	52 (40)	102 (50)	160 (50)	290 (60)	460 (70)	630 (80)	980 (120)	1300 (140)	1580 (160)							
				1T	Tendril 1 / 1-Step reduction	40 (40)	75 (50)	120 (50)	220 (60)	340 (70)	460 (80)	735 (120)	985 (140)	1145 (160)							
				2T	Tendril 1 / 2-Step reduction	27 (40)	40 (50)	70 (50)	130 (60)	195 (70)	255 (80)	405 (120)	565 (140)	670 (160)							
				3T	Tendril 1 / 3-Step reduction	10 (40)	21 (50)	46 (50)	75 (60)	105 (70)	140 (80)	240 (120)	310 (140)	415 (160)							
				FM	Tendril 2 / Full capacity	50 (40)	100 (50)	155 (50)	280 (60)	425 (70)	590 (80)	920 (120)	1240 (140)	1530 (160)							
				1M	Tendril 2 / 1-Step reduction	35 (40)	74 (50)	115 (50)	215 (60)	330 (70)	450 (80)	720 (120)	970 (140)	1130 (160)							
				2M	Tendril 2 / 2-Step reduction	23 (40)	33 (50)	65 (50)	120 (60)	190 (70)	240 (80)	380 (120)	550 (140)	640 (160)							
				3M	Tendril 2 / 3-Step reduction	8 (40)	18 (50)	38 (50)	67 (60)	100 (70)	130 (80)	220 (120)	290 (140)	390 (160)							
		E	Equal %	FC	General / Full capacity	76 (40)	160 (50)	256 (50)	430 (60)	740 (70)	1140 (80)	1650 (120)	2300 (140)	2700 (160)							
				1A	General / 1-Step reduction	46 (40)	98 (50)	156 (50)	260 (60)	450 (70)	680 (80)	1000 (120)	1400 (140)	1640 (160)							
				2A	General / 2-Step reduction	28 (40)	60 (50)	94 (50)	156 (60)	270 (70)	410 (80)	640 (120)	840 (140)	980 (160)							
				3A	General / 3-Step reduction	18 (40)	35 (50)	60 (50)	96 (60)	164 (70)	250 (80)	384 (120)	520 (140)	600 (160)							
				FT	Tendril 1 / Full capacity	50 (40)	82 (50)	135 (50)	235 (60)	370 (70)	500 (80)	840 (120)	1110 (140)	1400 (160)							
				1T	Tendril 1 / 1-Step reduction	35 (40)	58 (50)	95 (50)	170 (60)	265 (70)	370 (80)	600 (120)	785 (140)	1020 (160)							
				2T	Tendril 1 / 2-Step reduction	20 (40)	35 (50)	58 (50)	100 (60)	170 (70)	225 (80)	355 (120)	480 (140)	600 (160)							
				3T	Tendril 1 / 3-Step reduction	10 (40)	20 (50)	32 (50)	58 (60)	105 (70)	125 (80)	205 (120)	290 (140)	350 (160)							
				FM	Tendril 2 / Full capacity	47 (40)	74 (50)	130 (50)	230 (60)	330 (70)	470 (80)	770 (120)	1050 (140)	1320 (160)							
				1M	Tendril 2 / 1-Step reduction	33 (40)	56 (50)	92 (50)	165 (60)	245 (70)	330 (80)	570 (120)	720 (140)	960 (160)							
				2M	Tendril 2 / 2-Step reduction	19 (40)	33 (50)	52 (50)	95 (60)	145 (70)	190 (80)	330 (120)	430 (140)	550 (160)							
				3M	Tendril 2 / 3-Step reduction	8 (40)	16 (50)	25 (50)	52 (60)	80 (70)	110 (80)	190 (120)	270 (140)	295 (160)							
Y	Special	Y	Special	YY	Special	Contact Metso for Cv details															

NOTE
 1. Rated Cvs are applied differently depending on the trim type & trim characteristics.
 2. The bigger Cvs and sizes are available, please contact Metso.
 3. (Str) means the valve stroke in mm.
 4. The other Cvs and trim types : please contact Metso.

HOW TO ORDER

Angle Omega Trim, Multi-Stage Type, Series AM

1.	2.	3.	4.	5.	6.	7.	8.	9.	10.	11.	12.	13.	14.	15.	16.	17.	18.	19.	20.	21.	22.
AM	02	C	W	A	J2	B	P2	X	BC	S1	P2	X	S	G	G	S	A	X	A	E	FG

VALVE CONSTRUCTIONS

1.	VALVE SERIES
AM	Angle Omega trim, Multi-stage type

2.	BODY SIZE		
01	2" / DN 25	1h	1.5" / DN 40
02	2" / DN 50	03	3" / DN 80
04	4" / DN 100	06	6" / DN 150
08	8" / DN 200	10	10" / DN 250
12	12" / DN 300	14	14" / DN 350
16	16" / DN 400	18	18" / DN 450
20	20" / DN 500	24	24" / DN 600
YY	Special		

3.	PRESSURE RATING		
C	ASME class 150	D	ASME class 300
F	ASME class 600	G	ASME class 900
H	ASME class 1500	I	ASME class 2500
Y	Special		

4.	END CONNECTION
W	Flanged RF, ASME B16.5
Z	Ring joint flange, ASME B16.5
V	Socket welding, ASME B16.11
Q	Butt welding, ASME B16.25
Y	Special

5.	BONNET CONSTRUCTION	
	Bonnet Type	Actuator Connection
A	General	Applicable for VD_25/29/37
B	General	Applicable for VD_48/55
C	General	Applicable for VC_30, VB_32
D	General	Applicable for VC/VB_40/50/60/70
E	Extension	Applicable for VD_25/29/37
F	Extension	Applicable for VD_48/55
G	Extension	Applicable for VC_30, VB_32
H	Extension	Applicable for VC/VB_40/50/60/70
P	Cryogenic	Applicable for VD_25/29/37
Q	Cryogenic	Applicable for VD_48/55
R	Cryogenic	Applicable for VC_30, VB_32
S	Cryogenic	Applicable for VC/VB_40/50/60/70
Y	Special	Special

6.	BODY MATERIAL
J2	A216 gr. WCB
S6	A351 gr. CF8M
S1	A351 gr. CF3M
YY	Special

- Bonnet material is equivalent to Body material.

7.	MODEL CODE
B	Model B

TRIM CONSTRUCTIONS

8.	PLUG MATERIAL	
	Material	Description
P2	SUS 420J2	General for carbon steel valve
T6	CF8M + HCr	General for stainless steel valve
YY	Special	Special materials

9.	PLUG APPLICATION
X	Not applicable
A	Cobalt based alloy
Y	Special

10.	STEM MATERIAL	
	Material	Description
BC	630 SS + HCr	General for carbon steel valve
TC	316 SS + HCr	General for stainless steel valve
YY	Special	Special materials

11.	SEAT TYPE
S1	Single metal seat
YY	Special

12.	SEAT / RETAINER MATERIAL		
	Seat	Retainer	Guide Bushing
P2	SUS 420J2	SUS 420J2	SUS 420J2
R4	CF8M	316L SS	CF8M + HCr
YY	Special	Special	Special

13.	SEAT APPLICATION
X	Not applicable
A	Cobalt based alloy
Y	Special

OTHERS

14.	PACKING / BELLOWS TYPE
S	General packing
E	Low emission, Live loaded
C	Bellows Seal (316L SS, Formed)
Y	Special

17.	GASKET MATERIAL
S	S/W gasket type, 316 SS + Graphite for general
H	S/W gasket type, 316 SS + Graphite for high temp.
L	S/W gasket type, 316 SS + PTFE
Y	Special

15.	PACKING MATERIAL
G	PTFE + Carbon fiber
F	Graphite
T	PTFE V-Ring
H	Hi-Graphite
Y	Special

18.	STUD / NUT MATERIAL
A	A193 gr. B7 / A194 gr. 2H
B	A193 gr. B8 / A194 gr. 8
K	A320 gr. B8M cl. 2 / A194 gr. 8M
H	A193 gr. B16 / A194 gr. 4
Y	Special

16.	SEAL RING MATERIAL
G	PTFE + Graphite
T	PTFE
H	PTFE + Graphite + Carbon
X	Not applicable
Y	Special

19.	OPTIONS
X	Not applicable
E	Anti-erosion
L	Lub. & Isol. valve
W	Water seal
Y	Special

* Face to face length according to ISA 75.08
 * The body, bonnet, trim materials are subject to change as equivalent depending on detail design.
 * See 'NelesGlobe Type code Instruction' for further options and explanations.

TRIM TYPE & RATED Cv

20. Sign	TRIM TYPE	21. Sign	TRIM CHARACTERISTIC	22. Sign	Description	RATED Cv												
						Body size and stroke												
						1" Str.	1.5" Str.	2" Str.	3" Str.	4" Str.	6" Str.	8" Str.	10" Str.	12" Str.	14" Str.	16" Str.		
A P U	Balanced plug Pilot balanced plug Unbalanced plug	L	Linear	FG	Full capa. / Gas	8 (20)	18 (20)	30 (40)	62 (50)	96 (50)	168 (60)	290 (70)	440 (80)	640 (120)	880 (140)	1160 (160)		
				FL	Full capa. / Liquid													
				1G	1-Step red. / Gas	5 (20)	12 (20)	20 (40)	40 (50)	60 (50)	100 (60)	180 (70)	270 (80)	400 (120)	530 (140)	700 (160)		
				1L	1-Step red. / Liquid													
				2G	2-Step red. / Gas	3 (20)	8 (20)	12 (40)	26 (50)	40 (50)	64 (60)	110 (70)	160 (80)	240 (120)	320 (140)	420 (160)		
				2L	2-Step red. / Liquid													
				3G	3-Step red. / Gas	2 (20)	5 (20)	8 (40)	16 (50)	24 (50)	42 (60)	70 (70)	100 (80)	150 (120)	200 (140)	260 (160)		
				3L	3-Step red. / Liquid													
				E	Equal %	FG	Full capa. / Gas	5 (20)	10 (20)	18 (40)	38 (50)	60 (50)	104 (60)	176 (70)	268 (80)	390 (120)	540 (140)	710 (160)
						FL	Full capa. / Liquid											
						1G	1-Step red. / Gas	2.5 (20)	6 (20)	11 (40)	24 (50)	36 (50)	64 (60)	108 (70)	164 (80)	236 (120)	328 (140)	430 (160)
						1L	1-Step red. / Liquid											
						2G	2-Step red. / Gas	1.2 (20)	3 (20)	5 (40)	12 (50)	18 (50)	32 (60)	54 (70)	82 (80)	118 (120)	164 (140)	214 (160)
						2L	2-Step red. / Liquid											
3G	3-Step red. / Gas	0.6 (20)	1.5 (20)			2 (40)	6 (50)	9 (50)	16 (60)	27 (70)	40 (80)	60 (120)	82 (140)	106 (160)				
3L	3-Step red. / Liquid																	
Y	Special	Y	Special	YY	Special	Contact Metso for Cv details												

NOTE
 1. Rated Cvs are applied differently depending on the trim type & trim characteristics.
 2. The bigger Cvs and sizes are available, please contact Metso.
 3. (Str) means the valve stroke in mm.
 4. The other Cvs and trim types : please contact Metso.

Metso Corporation

Töölönlahdenkatu 2, PO Box 1220, 00100 Helsinki, Finland

Tel. +358 20 484 100

<http://contact.metso.com/>

Metso Flow Control Inc.

Vanha Porvoontie 229, P.O. Box 304, FI-01301 Vantaa, Finland.

Tel. +358 20 483 150. Fax +358 20 483 151

www.metso.com/valves

Subject to change without prior notice. Product names in this bulletin are all trademarks of Metso Flow Control Inc.

