

NELES® TRUNNION MOUNTED, BALL VALVES, FULL BORE, SERIES X

Metso's Neles® series X is a trunnion modular ball valve. Neles X series valves incorporate robust stem to ball connection. This assures valves are delivering solid long lasting performance in high cycle isolation and control applications. Application based seat selection assures valves are capable of delivering long lasting tightness even in most demanding applications including abrasive fluids and solids handling. Valve modularity widens the options in material selections to meet application specific requirements. Valves are also capable of delivering excellent control accuracy together with Metso Q-trim® anti-cavitation and noise reduction trim technology. Valve series meets modern industry requirements concerning safety and emissions.

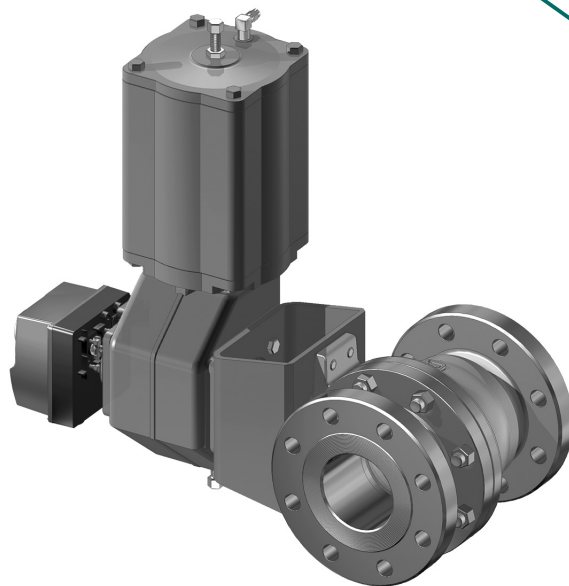

Applications

- Oil and gas production
- Chemical and petrochemical plants
- Power plants
- Liquids, gas and steam
- High temperature service
- Cryogenic service
- Hydrocarbons
- Catalyst handling
- Solids handling
- Polymers
- Control and tight shut-off applications
- High cycling
- Emergency applications ESD/ESV
- LNG
- Natural gas

Sizes/Pressure Classes

- 2"...16" / ASME Class 150 & 300.
- For ASME Class 600 and larger sizes refer to bulletin 1D21.

Trunnion mounted

- Low operating torque.
- Fully rated seats.
- Smooth control.
- Double block & bleed.
- Quick operations.
- High cycle capability.

Full bore

- Maximum Cv per nominal size.
- Cylindrical flow path allows low flow resistance.
- Full bore design for API requirements.

Increased safety

- V-ring gland packing ensures long maintenance free operation and low emission level.
- Live-loaded construction as standard.
- Fire tested API 607, with selected constructions and seat designs.
- Spiral wound body joint gasket.
- Anti-blowout shaft.

Tightness

- Durable two-way ISO 5208 Rate C or ANSI Class V tightness as standard with spring-loaded metal seats.
- Available with improved tightness rates.
 - API 598 for metal seats above 2".
- ISO 5208 Rate B or ANSI Class VI shut-off as standard with soft seats.

Minimized emissions

- Live-loaded gland packing.
 - ISO 15848
 - Clean Air Act.
- Off-center body joint.
 - Uninterrupted circular spiral wound body gasket.
 - No bending forces to gland packing.

Excellent control characteristics

- Equal percentage inherent characteristic.
- Self flushing, low noise anti-cavitation Q-TRIM® is optional.
- High noise reduction Q2-trim for gas applications.

EXPLODED VIEW

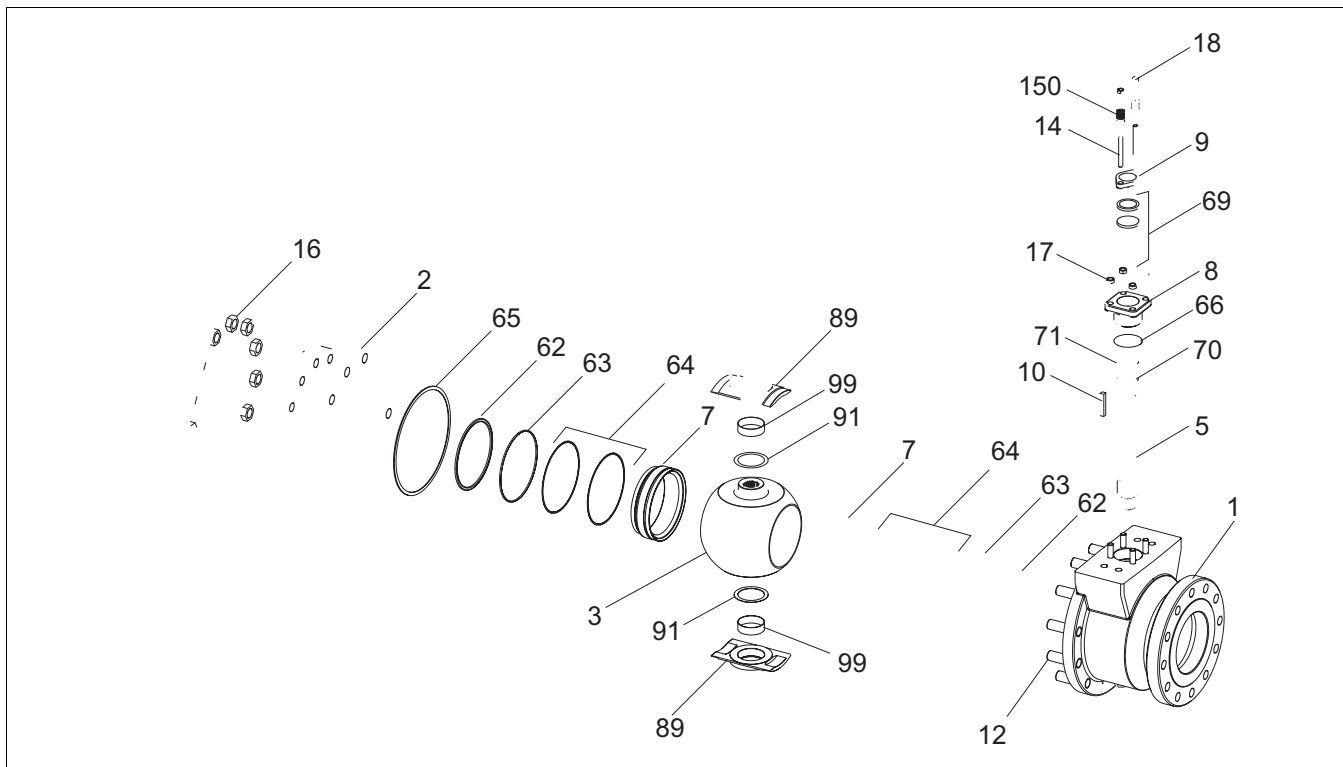

PARTS LIST

Item	Part description	Material		
1	Body	Stainless steel CF8M	Carbon steel WCB	Chrome Moly C5
2	Body cap	Stainless steel CF8M	Carbon steel WCB	Chrome Moly C5
3	Ball	Stainless steel AISI 316 / CF8M		Stainless steel 410
5	Shaft	Stainless steel 17-4PH / XM-19		
7	Ball seat	Stainless steel + cobalt based alloy / PTFE or filled PTFE		Stainless steel 410 +CrC
8	Bonnet	Stainless steel CF8M	Carbon steel WCB	Chrome Moly C5
9	Gland	Stainless steel CF8M		
10	Key	Stainless steel AISI 329		
12	Stud	ASTM A 193 gr. B8M	ASTM A 320 gr. L7M	
13	Stud	ASTM A 193 gr. B8M	ASTM A 320 gr. L7M	
14	Stud	ASTM A 193 gr. B8M	ASTM A 320 gr. L7M	
16	Hexagon nut	ASTM A 193 gr. 8M	ASTM A 194 gr. 2 HM	
17	Hexagon nut	ASTM A 193 gr. 8M	ASTM A 194 gr. 2 HM	
18	Hexagon nut	ASTM A 193 gr. 8M	ASTM A 194 gr. 2 HM	
62	Seat spring	Alloy 825		
63	Back seal	PTFE or graphite		
64	Back-up ring	PTFE		
65	Body gasket	Stainless steel AISI 316 + PTFE or graphite filled spiral wound		
66	Bonnet gasket	PTFE or graphite		
69	Packing ring	PTFE or graphite		
70	Thrust bearing	PTFE or cobalt based alloy		
71	Thrust bearing	Cobalt based alloy		
89	Trunnion plate	Stainless steel, ASTM A 351 gr. CF8M	Stainless steel, ASTM A743 gr. CA15	
91	Bearing spacer	Cobalt based alloy		
99	Trunnion bearing	PTFE + Stainless steel		
150	Disc spring set	Electroless nickel plated spring steel (EN 10083-1.8159)		

TECHNICAL SPECIFICATION

Product type

Full bore trunnion mounted ball valve.
Split body design.
Flanged.

Pressure ratings

ASME Class 150 and 300.

Size range

2"...16" in ASME Class 150 & 300.

Temperature range

-50 ... +400 °C / -60 ... +750 °F, consult factory for higher temperature applications.

Design standard

Valve body ASME B16.34.
Valve flanges ASME B16.5.
Face-to-face ASME B16.10 long pattern.
Actuator mounting ISO 5211.

Standard materials

Body ASTM A216 gr. WCB.
ASTM A351 gr. CF8M.
Ball ASTM A351 gr. CF8M/AISI 316 +
hard chrome plating with metal seats.
Bearings PTFE or cobalt based alloy.
Seats AISI 316+cobalt based alloy.
AISI 316+PTFE insert.
Seals/gaskets PTFE, graphite.
Body gaskets Spiral wound with PTFE or graphite
filler.

Gland packing

PTFE (V-ring) or graphite with live loaded construction.

Bolting

B8M/8M with stainless steel body.
L7M/2HM with carbon steel body.

Standard options

High temperature linkages.
Oxygen construction for gaseous oxygen service.
High temperature design.
Carbide or NiBo ball coating.
Q-TRIM design
Q2-TRIM design
NACE MR-01-03 as standard, NACE MR-01-75 on request.

Material and test certification

EN 10204-3.1 material certificates for body and bonnet.
Tightness test certificate.

Fire tested

API 607, with D and H seats.

Valve testing

Each valve is tested for body integrity and seat tightness.
The body test pressure is 1.5 x PN. The seat test pressure is 1.1 x PN. Test medium is inhibited water.
Air test upon request.

Valve tightness

ISO 5208 Rate C or Class V for metal seats.
ISO 5208 Rate B or Class VI for soft seats.
Other tightness rates upon request.

MAXIMUM ALLOWABLE Δp IN CONTROL SERVICE

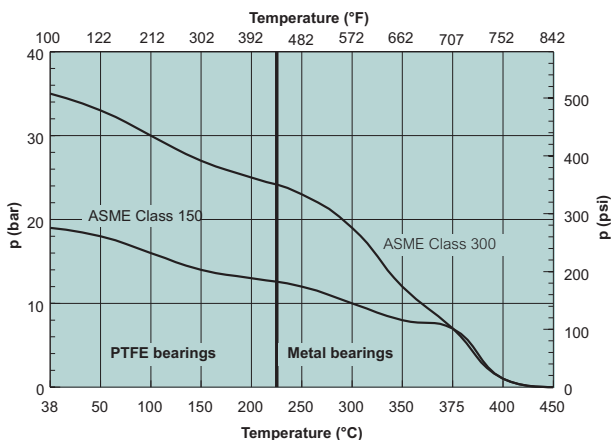

MAXIMUM ALLOWABLE Δp IN ON-OFF SERVICE

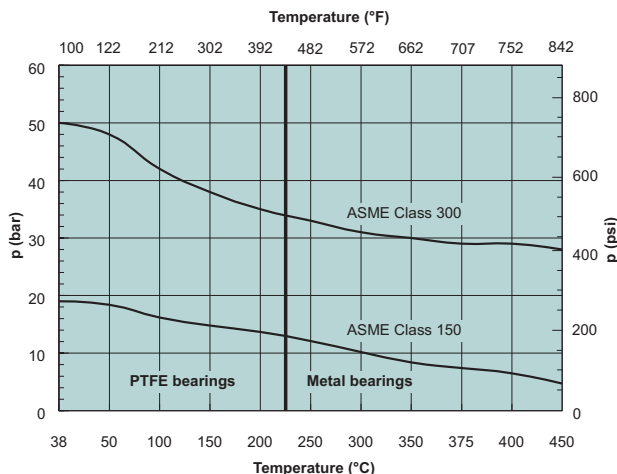

PTFE/metal bearings

Chrome plated ball

PTFE/metal bearings

Chrome plated ball

Note: When Carbide or Nickel Boron coatings are used according to given technical limitations, max body material P/T values can be used. Always consider shaft strength, consult factory.

STANDARD SEAT CONSTRUCTIONS AND MATERIALS

S

Metal seat

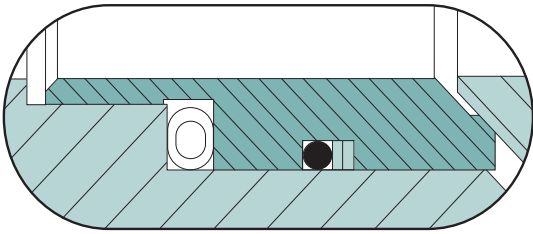

Ball seat: Stainless steel + hard facing.
 Seat seal: Viton® GF O-ring.
 Spring: INCONEL® 625.
 Temp. range: -30 ... +200 °C / -22 ... +390 °F.

B

Solids proof metal seat

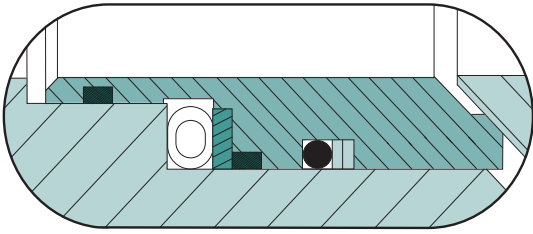

Ball seat: Stainless steel + hard facing.
 Seat seal: Viton® GF O-ring/graphite.
 Spring: INCONEL® 625.
 Temp. range: -30 ... +200 °C / -22 ... +390 °F.
 Fire safe

K

High temperature solids proof metal seat

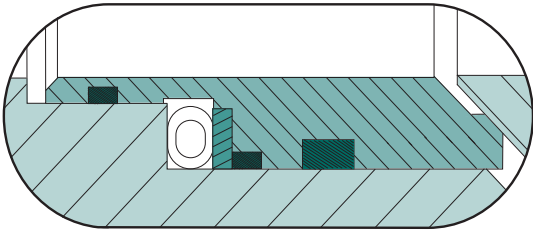

Ball seat: Stainless steel + hard facing.
 Seat seal: Graphite/graphite
 Spring: INCONEL® 625.
 Temp. range: -50 ... 450 °C / -60 ... +840 °F.
 Fire safe

L

Polymer proof seat

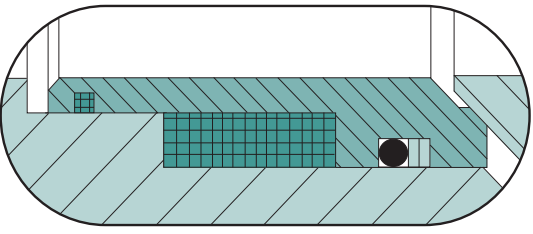

Ball seat: Stainless steel + hard facing.
 Seat seal: Viton GF O-ring / Graphite.
 Temp. range: - 30 ... +200 °C / -22 ... +390 °F.
 Note: - Sizes 2" - 8"
 - Size 10" with single seat design only.

H

Bellows seat

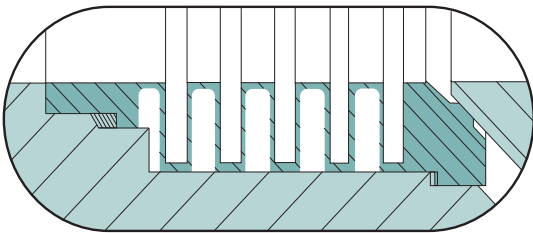

Ball seat: Stainless steel + hard facing.
 Seat seal: Graphite.
 Temp. range: -50 ... +400 °C / -60 ... +750 °F.
 Note: For temperature above +400 °C / +750 °F please consult factory.
 Not available for XM (Class 150) sizes 2"-6" / DN 50-150

STANDARD SEAT CONSTRUCTIONS AND MATERIALS

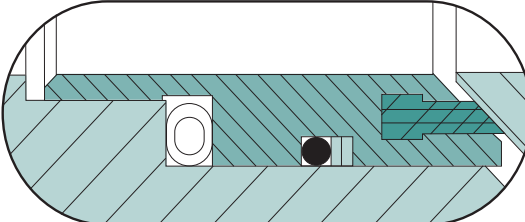
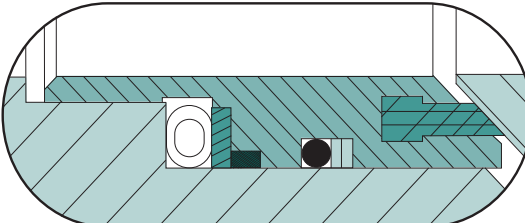
T	<p style="text-align: center;">Soft seat</p> 	<p>Ball seat: Seat body: Seat seal: Spring: Temp. range:</p>	<p>PTFE. Stainless steel. Viton GF O-ring. INCONEL 625. -30 ... +200 °C / -22 ... +390 °F.</p>
D	<p style="text-align: center;">Soft seat, fire safe</p> 	<p>Ball seat: Seat body: Seat seal: Spring: Temp. range:</p>	<p>PTFE. Stainless steel. Viton GF O-ring. INCONEL 625. -30 ... +200 °C / -22 ... +390 °F.</p>

ACTUATOR SELECTION

X-series valve can be equipped with the following Metso actuator types:

B1C/B1J Pneumatic double acting or spring return actuator.
Actuators available for size range DN 50 - 400 / 2"-16"
B1C/B1J actuators have an ISO 5211 mounting face.

M Gear operator for valve sizes DN 50-300 / 2"-12".

When selecting other actuators, please contact your local Metso representative.

For the correct actuator selection in on-off service, you need to know the following process data:

- valve size and seat type
- supply pressure for the actuator
- maximum shut-off pressure across the valve.

DIMENSIONS

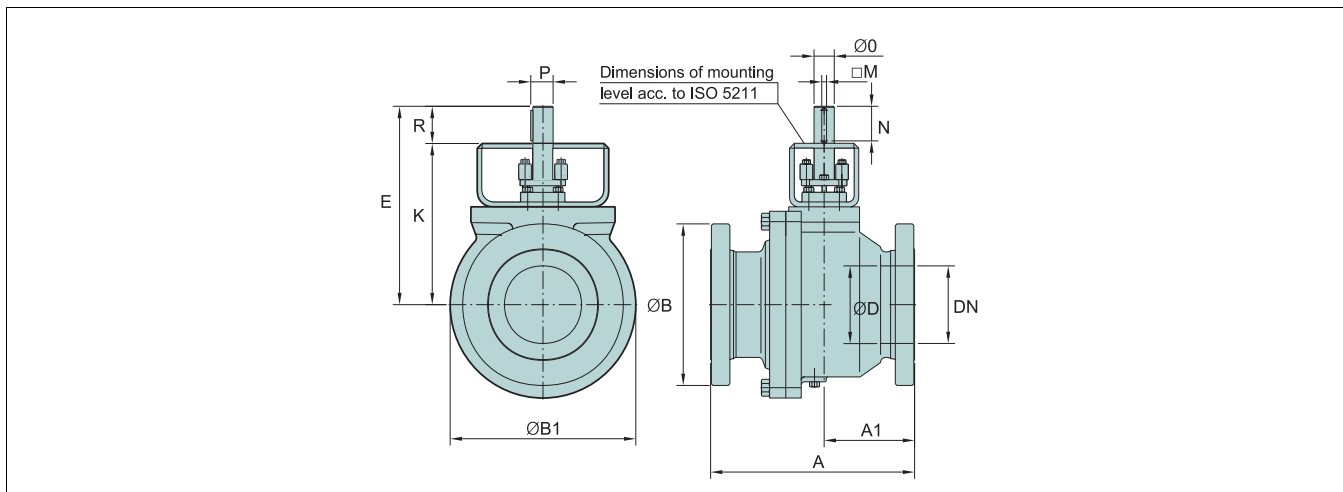

ASME 150

Size	ISO FLANGE	DIMENSIONS, mm												kg
		A	A1	ØB	ØB1	ØD	E	K	□M	N	ØO	P	R	
50	F07, F10	178	79	150	146	50.8	203	168	4.76	35	20	22.16	35	10
80	F07, F10, F12, F14	203	96.5	190	190	76.2	225	190	4.76	35	20	22.16	35	22
100	F10, F12, F14	229	112	230	241	101.6	296	250	6.35	46	25	27.75	46	32
150	F14, F16	394	197	280	338	152.4	373	305	9.53	68	40	44.23	68	75
200	F14, F16, F25	457	229	343	426	203.2	453	385	9.53	68	40	44.23	68	190
250	F14, F16, F25, F30	533	267	407	514	254	562	472	12.7	90	55	60.6	90	325
300	F14, F16, F25, F30	610	305	483	592	304.8	605	515	12.7	90	55	60.6	90	480
350	F16, F25, F30, F35	686	343	533	665	340	741	607	19.05	134	75	83.15	134	635
400	F16, F25, F30, F35	762	381	597	750	390	779	633	22.23	146	85	94.63	146	840

Face-to-face dimension acc. to ANSI B16.10, Table 1, long pattern

Size	ISO FLANGE	DIMENSIONS, inch												lbs
		A	A1	ØB	ØB1	ØD	E	K	□M	N	ØO	P	R	
2	F07, F10	7.01	3.11	5.91	5.75	2.00	7.99	6.61	0.19	1.38	0.79	0.87	1.38	22
3	F07, F10, F12, F14	7.99	3.80	7.48	7.48	3.00	8.86	7.48	0.19	1.38	0.79	0.87	1.38	48.4
4	F10, F12, F14	9.02	4.41	9.06	9.49	4.00	11.65	9.84	0.25	1.81	0.98	1.09	1.81	70.4
6	F14, F16	15.51	7.76	11.02	13.31	6.00	14.69	12.01	0.38	2.68	1.57	1.74	2.68	165
8	F14, F16, F25	17.99	9.02	13.50	16.77	8.00	17.83	15.16	0.38	2.68	1.57	1.74	2.68	418
10	F14, F16, F25, F30	20.98	10.51	16.02	20.24	10.00	22.13	18.58	0.50	3.54	2.17	2.39	3.54	715
12	F14, F16, F25, F30	24.02	12.01	19.02	23.31	12.00	23.82	20.28	0.50	3.54	2.17	2.39	3.54	1056
14	F16, F25, F30, F35	27.01	13.50	20.98	26.18	13.39	29.17	23.90	0.75	5.28	2.95	3.27	5.28	1397
16	F16, F25, F30, F35	30.00	15.00	23.50	29.53	15.35	30.67	24.92	0.88	5.75	3.35	3.73	5.75	1848

Face-to-face dimension acc. to ANSI B16.10, Table 1, long pattern

ASME 300

TYPE	DN	ISO FLANGE	DIMENSIONS, mm												kg
			A	A1	ØB	ØB1	ØD	E	K	□M	N	ØO	P	R	
XG	50	F07, F10	216	89	165	146	50.8	203	168	4.76	35	20	22.16	35	15
	80	F07, F10, F12, F14	282	141	210	200	76.2	225	190	4.76	35	20	22.16	35	32
	100	F10, F12, F14	305	152	255	254	101.6	296	250	6.35	46	25	27.75	46	58
	150	F14, F16	403	201	320	353	152.4	373	305	9.53	68	40	44.23	68	125
	200	F14, F16, F25	502	249	380	462	203.2	453	385	9.53	68	40	44.23	68	225
	250	F14, F16, F25, F30	568	284	445	580	254.0	562	472	12.70	90	55	60.60	90	330
	300	F14, F16, F25, F30	648	324	520	652	304.8	605	515	12.70	90	55	60.60	90	610
	350	F16, F25, F30, F35	762	381	585	700	340.0	741	607	19.05	134	75	83.15	134	800
	400	F16, F25, F30, F35	838	419	650	799	390.0	779	633	22.23	146	85	94.63	146	1015

TYPE	SIZE	ISO FLANGE	DIMENSIONS, inch												lbs
			A	A1	ØB	ØB1	ØD	E	K	□M	N	ØO	P	R	
XG	2	F07, F10	8.50	3.50	6.50	5.75	2.0	7.99	6.61	0.19	1.38	0.79	0.87	1.38	33
	3	F07, F10, F12, F14	11.12	5.55	8.25	7.87	3.0	8.86	7.48	0.19	1.38	0.79	0.87	1.38	70
	4	F10, F12, F14	12.00	6.00	10.00	10.00	4.0	11.65	9.84	0.25	1.81	0.98	1.09	1.81	128
	6	F14, F16	15.88	7.93	12.50	13.90	6.0	14.69	12.01	0.38	2.68	1.57	1.74	2.68	276
	8	F14, F16, F25	19.75	9.80	15.00	18.19	8.0	17.83	15.16	0.38	2.68	1.57	1.74	2.68	496
	10	F14, F16, F25, F30	22.38	11.18	17.50	22.83	10.0	22.13	18.58	0.50	3.54	2.17	2.39	3.54	727
	12	F14, F16, F25, F30	25.50	12.76	20.50	25.67	12.0	23.82	20.28	0.50	3.54	2.17	2.39	3.54	1345
	14	F16, F25, F30, F35	30.00	15.00	23.00	27.56	13.4	29.17	23.90	0.75	5.27	2.95	3.27	5.27	1764
	16	F16, F25, F30, F35	33.00	16.50	25.50	31.46	15.4	30.67	24.92	0.88	5.75	3.35	3.73	5.75	2237

Face-to-face dimension acc. to ANSI B16.10, Table 2, long pattern

*) See K dimension from tables on page 6.

VALVE + B1C/B1J/B1JA

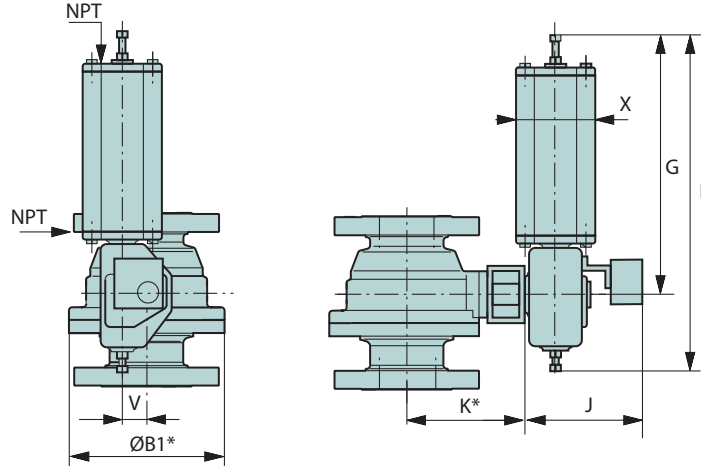

*) See K and ØB1 dimension from tables on page 6.

B1C ACTUATOR

Actuator	DIMENSIONS, mm					NPT	kg
	F	G	J	V	X		
B1C6	400	260	283	36	90	1/4	4.2
B1C9	455	315	279	43	110	1/4	9.6
B1C11	540	375	290	51	135	3/8	16
B1C13	635	445	316	65	175	3/8	31
B1C17	770	545	351	78	215	1/2	54
B1C20	840	575	385	97	215	1/2	73
B1C25	1040	710	448	121	265	1/2	131
B1C32	1330	910	525	153	395	3/4	256
B1C40	1660	1150	595	194	505	3/4	446
B1C50	1970	1350	690	242	610	1	830

Actuator	DIMENSIONS, inch					NPT	lbs
	F	G	J	V	X		
B1C6	15.75	10.24	11.14	1.42	3.54	1/4	9
B1C9	17.91	12.40	10.98	1.69	4.33	1/4	21
B1C11	21.26	14.76	11.42	2.01	5.31	3/8	35
B1C13	25.00	17.52	12.44	2.56	6.89	3/8	68
B1C17	30.31	21.46	13.82	3.07	8.46	1/2	119
B1C20	33.07	22.64	15.16	3.82	8.46	1/2	161
B1C25	40.94	27.95	17.64	4.76	10.43	1/2	289
B1C32	52.36	35.83	20.67	6.02	15.55	3/4	564
B1C40	65.35	45.28	23.43	7.64	19.88	3/4	983
B1C50	77.56	53.15	27.17	9.53	24.02	1	1829

B1J/B1JA ACTUATOR

Actuator	DIMENSIONS, mm					NPT	kg
	F	G	J	V	X		
B1J/B1JA6	485	368	273	36	110	3/8	8
B1J/B1JA8	560	420	279	43	135	3/8	17
B1J/B1JA10	650	490	290	51	175	3/8	30
B1J/B1JA12	800	620	316	65	215	1/2	57
B1J/B1JA16	990	760	351	78	265	1/2	100
B1J/B1JA20	1200	935	358	97	395	3/4	175
B1J/B1JA25	1530	1200	448	121	505	3/4	350
B1J/B1JA32	1830	1410	525	153	540	1	671
B1J/B1JA40	2095	1578	580	194	724	1	1100

Actuator	DIMENSIONS, inch					NPT	lbs
	F	G	J	V	X		
B1J/B1JA6	19.09	14.49	10.75	1.42	4.33	3/8	20
B1J/B1JA8	22.05	16.54	10.98	1.69	5.31	3/8	37
B1J/B1JA10	25.59	19.29	11.42	2.01	6.89	3/8	66
B1J/B1JA12	31.50	24.41	12.44	2.56	8.46	1/2	126
B1J/B1JA16	38.98	29.92	13.82	3.07	10.43	1/2	220
B1J/B1JA20	47.24	36.81	14.09	3.82	15.55	3/4	386
B1J/B1JA25	60.24	47.24	17.64	4.76	19.88	3/4	771
B1J/B1JA32	72.05	55.51	20.67	6.02	21.26	1	1479
B1J/B1JA40	82.48	62.13	22.8	7.64	28.5	1	2424

HOW TO ORDER

1.	2.	3.	4.	5.	6.	7.	8.	9.	10.	11.
XG	06	D	W	TA	S6	PJ	S	A	B	E

1. sign	VALVE SERIES & STYLE & FACE-TO-FACE
XM	Full bore, trunnions, f-to-f ANSI B 16.10, Table 1, long pattern, ASME 150.
XG	Full bore, trunnions, f-to-f ANSI B 16.10, Table 2, long pattern, ASME 300.

2. sign	SIZE		
	ASME VALVES	EN VALVES	
2. sign	NPS	2. sign	DN
02	2"	050	50
03	3"	080	80
04	4"	100	100
06	6"	150	150
08	8"	200	200
10	10"	250	250
12	12"	300	300
14	14"	350	350
16	16"	400	400

3. sign	PRESSURE CLASS
C	ASME Class 150
D	ASME Class 300
J	PN 10
K	PN 16
L	PN 25
M	PN 40

4. sign	END CONNECTION STYLE
W	Raised face, ASME B 16.5, (Ra 3.2 - 6.3/RMS 125 - 250) standard with ASME flanges.
C	EN 1092 -1 Type B1, raised face, standard with EN flanges.

5. sign	CONSTRUCTION & APPLICATION
TA	Standard construction. Live loaded packing.
TE	Single seated. Otherwise standard.
TQ	Q-Trim construction. Otherwise standard
EQ	Single seated, Q-Trim construction.
2G	Q2-trim for gas application, single seated construction, otherwise standard construction
TZ	BAM tested non-metallic parts, for oxygen service. Double seated. Metal bearings; cobalt based alloy. Live loaded graphite packing. Temperature range -50...+200 °C. Max pressure per body rating. Oxygen cleaning acc. to Metso internal procedure FC-QC-0001 included.

6. sign	BODY MATERIAL
J2	ASTM A216 gr WCB
S6	ASTM A351 gr CF8M
J5	ASTM A217 gr C5

7. sign	BALL / COATING & STEM MATERIAL
PJ	316SS / Hard Chrome & 17-4PH
PP	316SS & 17-4PH
PX	316SS / Chrome carbide & 17-4PH
PR	316SS / WC-CO & 17-4PH
PL	316SS / NiBo & 17-4PH

NOTE ! Balls with coating (/) are normally used in metal seated valves.

8. sign	SEAT TYPES AND BACK SEAL/SPRING MATERIALS			
	Seat type	Back seal type	Spring	Back-up ring
S	S, metal, general service	O-ring	Inconel 625	PTFE
L	L, metal, Polymer proof	Graphite / O-ring		PTFE
B	B, metal, solid proof	Graphite/ O-ring	Inconel 625	PTFE
K	K, metal, solid proof	Graphite/graphite	Inconel 625	
H	H, metal, bellows	Graphite	----	----
T	T, soft, general service	O-ring	Inconel 625	PTFE
D	D, soft fire safe service	Graphite / O-ring	Inconel 625	PTFE

9. sign	SEAT AND COATING MATERIAL	
	Seat material	Coating
A	Type 316 stainless steel with S, B and L type seats AVESTA 248SV with H type seat.	Cobalt based hard facing
R	Type 316 stainless steel with S, B and L type seats AVESTA 248SV with H type seat.	Tungsten Carbide, WC-CO
B	Type 316 stainless steel with S, B and L type seats AVESTA 248SV with H type seat.	Chrome Carbide, CrC-LF
F	F6NM with H-type seat for high temperature NACE service.	Chrome Carbide, CrC-LF
	Seat material	Insert
T	Type 316 stainless steel.	PTFE
M	Type 316 stainless steel.	Filled PTFE
N	Type 316 stainless steel.	Polyamid

10. sign	BEARING AND SEAL MATERIALS				
	Trunnion bearing	Packings	Body gaskets	O-rings	Thrust bearing
A	PTFE / SS net	V-rings PTFE	PTFE	Viton GF	Cobalt based alloy
B	PTFE / SS net	Graphite	Graphite	Viton GF	Cobalt based alloy
C	Cobalt based alloy	V-rings PTFE	PTFE	Viton GF	Cobalt based alloy
D	Cobalt based alloy	Graphite	Graphite	Viton GF	Cobalt based alloy
H	PTFE / SS net	V-rings PTFE	PTFE	EPDM	Cobalt based alloy
S	PTFE / SS net	Graphite	Graphite	EPDM	Cobalt based alloy

11. sign	BOLTING MATERIALS			
	Pressure retaining		Packing gland bolting	
	Studs	Nuts	Studs	Nuts
For low emission gland packing design ISO 15848				
E*	B8M	8M	gr. 660	gr. 660
T**	L7M	2HM	B7	2H
For general service gland packing				
D*	B8M	8M	B8M	8M
F**	L7M	2HM	L7M	2HM

* Bolting materials for stainless steel body

** Bolting materials for carbon and low alloy steel body

Metso Corporation

Töölönlahdenkatu 2, PO Box 1220, 00100 Helsinki, Finland
Tel. +358 20 484 100

Metso Flow Control Inc.

Vanha Porvoontie 229, P.O. Box 304, FI-01301 VANTAA, Finland.
Tel. +358 20 483 150. Fax +358 20 483 151

www.metso.com/valves

Subject to change without prior notice. Product names in this bulletin are all trademarks of Metso Flow Control Inc.

