

## NELES FINETROL® ECCENTRIC ROTARY PLUG CONTROL VALVE, SERIES FC

Finetrol® eccentric rotary plug valves are economical high-performance control valves designed to provide the best possible control accuracy and wide rangeability with the all inherent benefits of rotary control valves. Standard units are equipped with spring-diaphragm actuators and ND9000® intelligent valve controllers for precise flow control, extended operational life and performance monitoring on-line.



### FEATURES

#### Versatility: wide application range

- Finetrol valves are suitable for liquid, gas, steam and slurry applications.
- All actuator mounting directions can be used
- Temperature limits -80 °C ... +425° / -112 °F...+797 °F with the standard construction.  
Cryogenic version -200 °C / -328 °F.
- Full conformity to both ASME and EN standard requirements.
- Fulfils NACE MR0103-2003 requirements.

#### Accurate control

- The plug shape of the Finetrol valve is engineered to offer a constant gain expanded to a full 90° rotation.
- Optimum flow characteristic through plug shape, instead of positioner cams, provides control valve dynamic performance and control loop stability.
- Plug shape provides balanced dynamic torque.
- High rangeability minimizes need for reduced C<sub>v</sub>-trim and trim changes.

#### Safety

- SIL 3 certified
- Fire-tested and certified.
- Anti-blowout feature is achieved by enlarged stem diameter.
- Valve turns clockwise to close.
- Rugged one-piece-body construction minimizes potential leak paths and makes the valve insensitive to pipe stress.

#### Environmental design

- Live loaded standard packing and rotary operation reduces emissions dramatically compared to sliding stem valves
- ISO 15848-1 Class BH certified with endurance class CC-3 (100 000 mechanical cycles). Standard packing construction meets the Clean Air Act, TA-Luft and SPE 77/312 requirements.

#### Low cost of ownership

- Large diameter shafts and heavy duty bearings.
- Heavy duty reliable actuators.
- Predictive maintenance and asset management features.

#### Noise/cavitation abatement

- Patented Q-Trim®: rotating attenuator design provides up to 18 dB (A) noise attenuation, self-flushing for impure fluids, high Cv and wide rangeability.
- Q-Trim + valve outlet attenuator plate construction extends Q-Trim performance for high pressure drop ratios and provides extra noise attenuation, up to 23 dB (A).

#### Easy maintenance

- Seat can be removed without valve disassembly.
- Spiral groove joint between seat and the valve body guarantees perfect alignment of seat without feeler gauges or lapping.
- Heavy square threads between valve body and seat ensures easy seat removal (rusting and jamming prevented).
- No pins, retaining bolts or shims.
- Valve assembly is simple and self-aligning.

### TECHNICAL SPECIFICATION

**Product type** Eccentric rotary plug valve, flanged  
**Sizes** **DN** 25, 40, 50, 80, 100, 150, 200, 250  
**Inch** 1, 1 1/2, 2, 3, 4, 6, 8, 10  
**Pressure ratings** ASME Class 150-600 / PN10-100.  
**End connections** See table 1. on page 3.  
**Face-to-face**  
**Design FC:** ASME/ISA 75.08.02 = IEC/EN 60534-3-2  
**Maximum shut-off pressure**  
 See table 2. on page 3.  
 See page 6 for maximum pressure drops available with different actuators.  
**Shut-off classification** Class VI with soft seat (1"~6")  
 Class IV with metal seat per ANSI FCI 70-2.  
 (0.01 % of valve rated capacity).  
**Materials** See page 5.  
**Temperature range** Metal seat: -200...+425 °C  
 See table 3. on page 3.  
 Softseat: -50...+260 °C  
**Trim style** Quarter turn eccentric rotary plug.

**Flow characteristic** Inherent linear characteristics. Please use the valve selection and sizing tool to verify the installed gain and flow characteristics according to the process data.  
**Flow direction** FTO = FLOW TO OPEN. Flow through seat ring and past the plug. Standard flow direction.  
 FTC = FLOW TO CLOSE. Flow past the plug and through the seat ring. Recommended for erosive and flashing services.

**Flow capacity** See table below.  
**Valve plug rotation** Clockwise to close.  
**OPTIONS**  
**Q-trim**  
**Sizes** **DN** 50, 80, 100, 150, 200, 250  
**Inch** 2, 3, 4, 6, 8, 10  
**Plates on valve outlet**  
 Attenuator plate = standard plate used in gas applications.  
 Q2 plate = advanced noise attenuation plate for gas application including 3 capacity options.  
 Baffle plate = customized plate used in liquid applications.  
**Reduced Cv trim** One reduction (50 %)/size is available on standard metal seated valve.

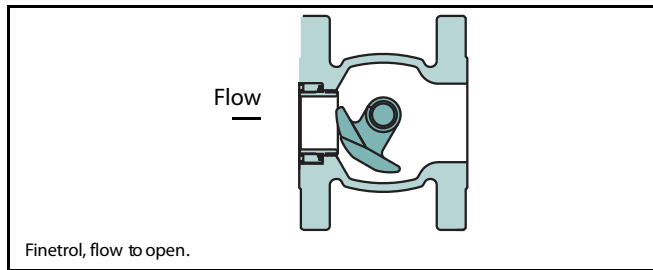

### NOISE ATTENUATION

Q-Trim attenuator plates rotate with the plug.

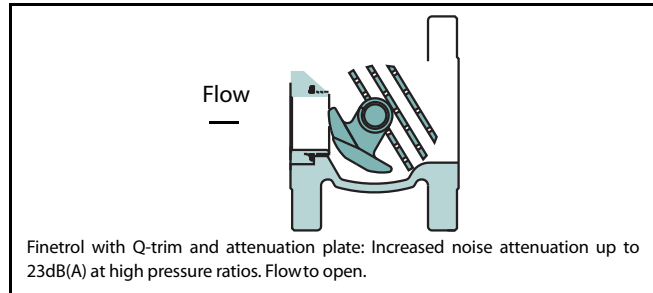

### FLOW DIRECTION RECOMMENDATION

Flow to open direction produces typically 2-4 dB (A) lower noise level.

Application/Construction	Flow to open	Flow to close
General	x	(x)
Erosive	-	x
Vacuum after valve	-	x
Noise attenuating trims	x	-
High temperature	x	(x)
Flashing	-	x

Flow direction is marked on each FINETROL valve by a flow direction arrow.  
 X = recommended.  
 (X) = optional

### MAXIMUM C<sub>v</sub>-VALUES

Valve size DN Size/red"	Valve size inch Size/red	90° ROTATION								
		Standard Metal Seat				Soft seat		Q trim with metal seat		Q trim with soft seat
		FTO		FTC		FTO	FTC	FTO		FTO
		Cv100 %	CvR100 %	Cv100 %	CvR100 %	Cv100 %	Cv100 %	Cv100 %	CvR100 %	Cv100 %
25	1	14,5	7,9	16,5	7,9	7,5	8	-	-	-
40	1 1/2	31	15,5	39	15,5	17,5	22	-	-	-
50	2	52	26	62	26	35	40	31	22	25
80	3	137	66	155	66	105	120	84	56	75
100	4	239	120	265	120	195	220	144	95	130
150	6	520	260	575	260	440	359	310	210	290
200	8	870	440	1050	440	730	880	540	350	490
250	10	1330	680	1540	680	1100	1250	840	550	760

C<sub>v</sub> R = 50 % reduced C<sub>v</sub> seat.

FTO = Flow to open

FTC = Flow to close

### PRESSURE RATINGS AND FLANGE COMPATIBILITY

Size inch	ASME Flanged			Size DN	EN Flanged					
	Class 150 <sup>1</sup>	Class 300	Class 600		PN 10 <sup>2</sup>	PN 16 <sup>2</sup>	PN 25 <sup>2</sup>	PN 40 <sup>2</sup>	PN 63 <sup>3</sup>	PN100 <sup>3</sup>
1	x	x	x <sup>5</sup>	25	x	x	x	x	x	x
1 1/2	x	x	x	40	x	x	x	x	x	x
2	x	x	x <sup>4</sup>	50	x	x	x	x	x	x
3	x	x	x <sup>4</sup>	80	x	x	x	x	x <sup>4</sup>	x <sup>4</sup>
4	x	x	x <sup>4</sup>	100	x	x	x	x	x <sup>5</sup>	x <sup>5</sup>
6	x	x	x <sup>4</sup>	150	x	x	x	x	x <sup>4</sup>	x <sup>4</sup>
8	x	x	x <sup>4</sup>	200	x	x	x	x	x <sup>4</sup>	x <sup>4</sup>
10	x	x	x <sup>4</sup>	250	x	x	x	x	x <sup>4</sup>	x <sup>4</sup>

x = available

<sup>1</sup> In ASME 150 valve, the flange drilling is according to class 150, while flange thickness according to ASME 300

<sup>2</sup> ASME class 300 flange thickness.

<sup>3</sup> ASME class 600 flange thickness.

<sup>4</sup> 2 threaded flange drillings in the valve neck area.

<sup>5</sup> All flange wholes are threaded drillings

### MAXIMUM PRESSURE/TEMPERATURE RATINGS

**A 216 Gr. WCC**

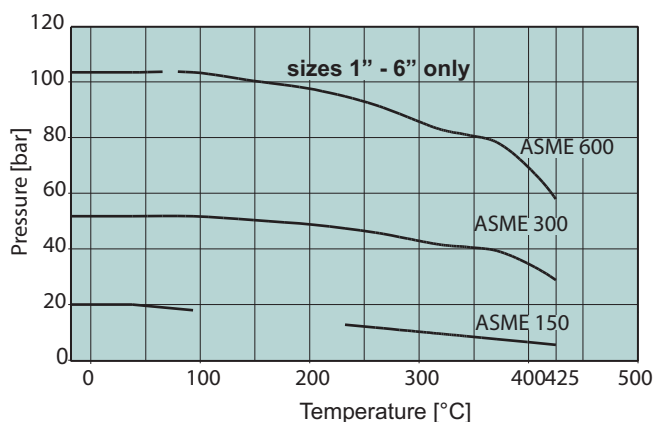

**W.No. 1.0619**

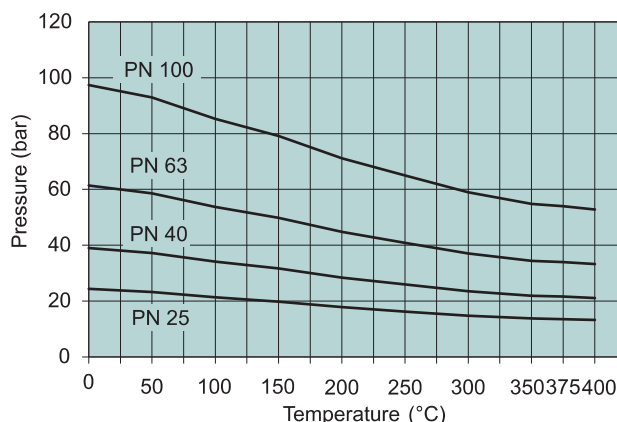

**A 351 Gr. CF8M**

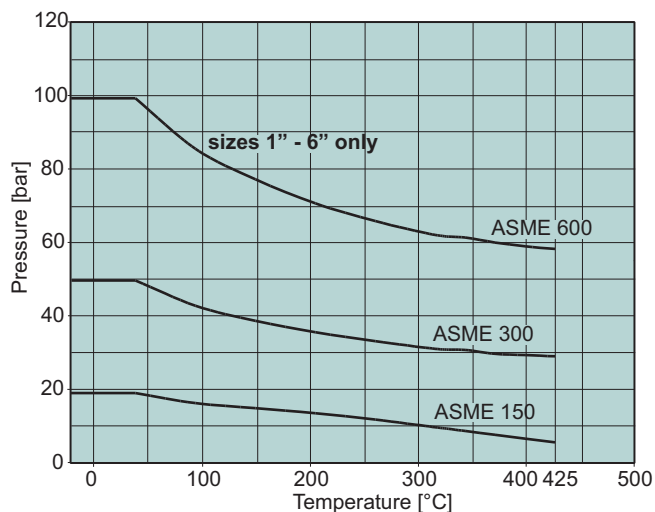

**W.No. 1.**

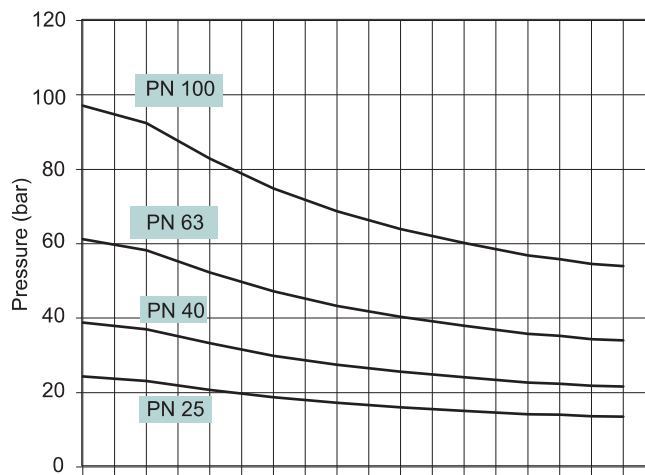

Note: For applications involving cavitation, impurities or excessive noise, contact Metso for max Δp.

### TEMPERATURE RANGES

	Metal seat valve		Soft seat valve	
	WCC/1.0619 body	CF8M/1.4408 body	CF8M Low temperature/cryo	
	-29 ... +425 °C*	-20 ... +797 °F*	-29 ... +260 °C*	-20 ... +500 °F*
	-80 ... +425 °C*	-112 ... +797 °F*	-50 ... +260 °C*	-58 ... +500 °F*
	-200 °C (min)**	-328 °F**	N/A	N/A

Graphite (PTFE lubricated) packing is recommended above 250 °C / 482 °F and for firesafe applications.

\* Standard construction, no extension pipe needed.

\*\* Extension pipe needed.

**17-4PH shaft in Flow-to-Open direction**

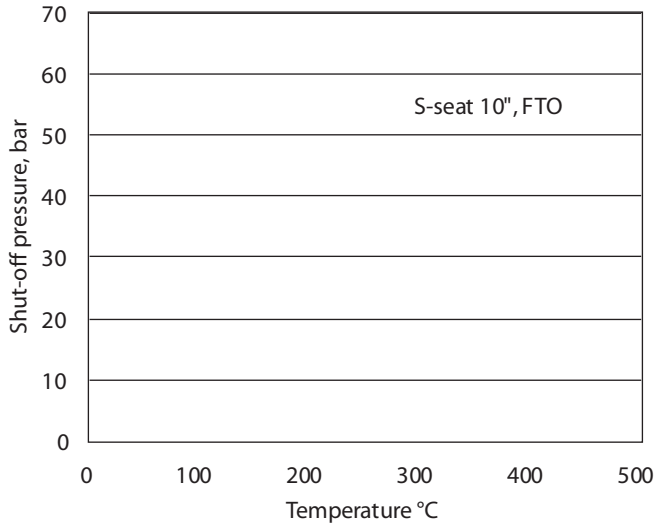

Other sizes as per valve body pressure rating  
FTO = Flow to open

**17-4PH shaft in Flow-to-Close direction**

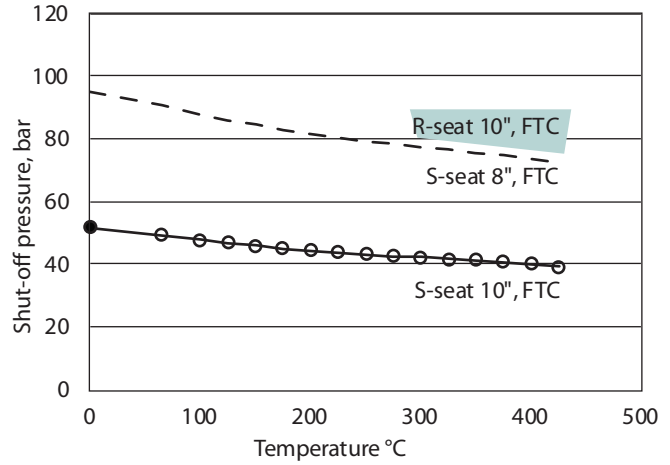

Other sizes as per valve body pressure rating  
FTC = Flow to close

**XM-19 shaft in Flow-to-Open direction**

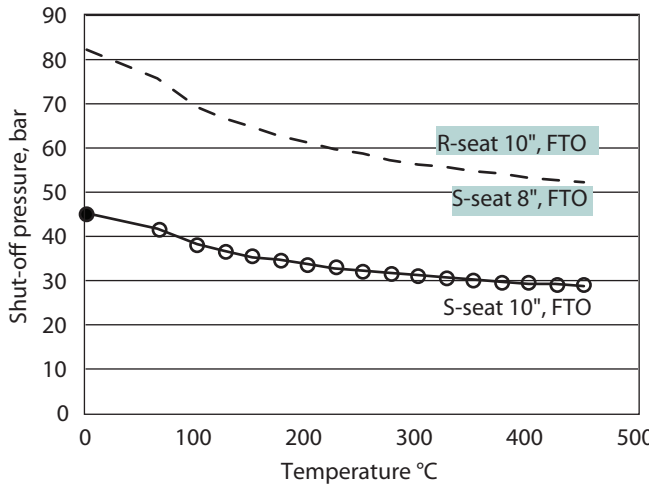

Other sizes as per valve body pressure rating  
FTO = Flow to open

**XM-19 shaft in Flow-to-Close direction**

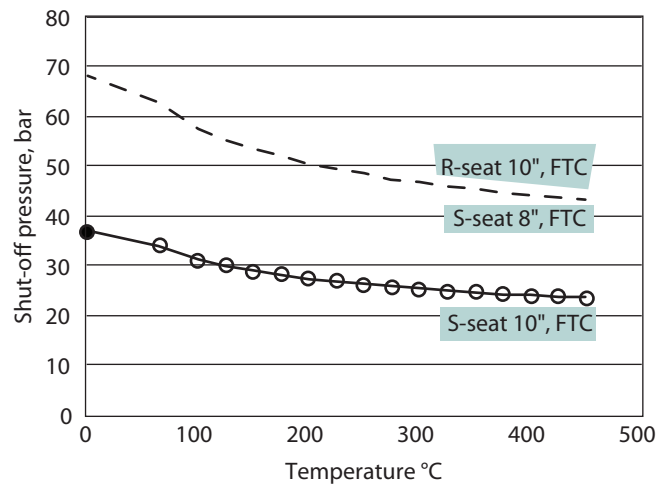

Other sizes as per valve body pressure rating  
FTC = Flow to close

**OPERATING PRINCIPLE OF THE FINETROL WITH Q-TRIM**

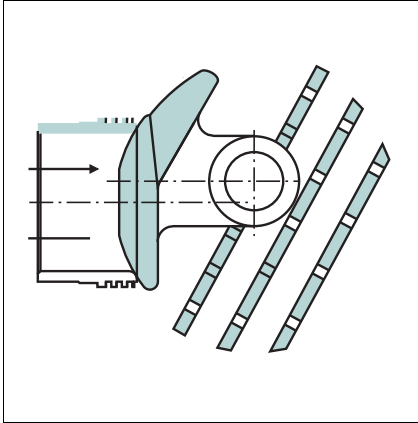

0 degree rotation / Closed position

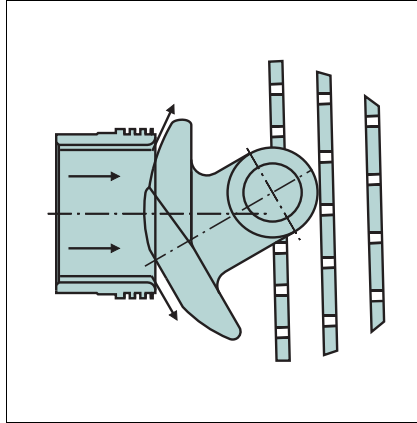

30 degree rotation showing effect of patented balanced eccentric rotary plug design

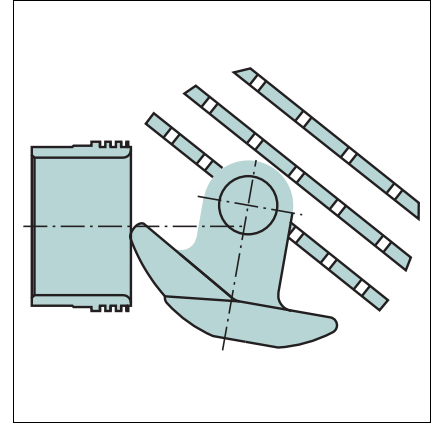

Open position / 80 degree rotation

**STANDARD BONNET CONSTRUCTIONS**

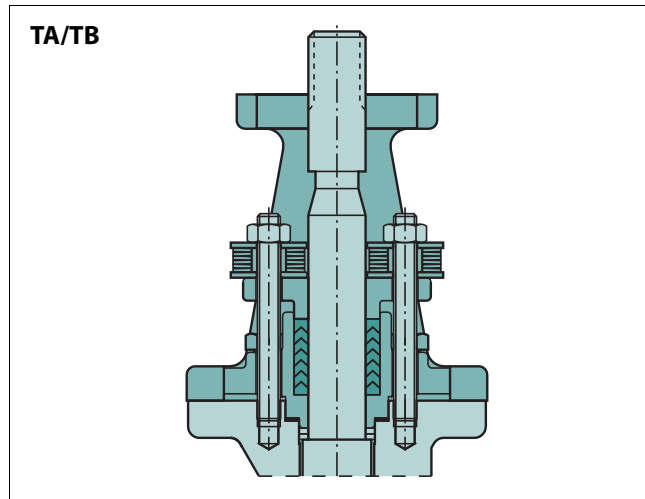

Live-loaded PTFE / V-ring construction.  
TA-Luft certified. Standard construction.

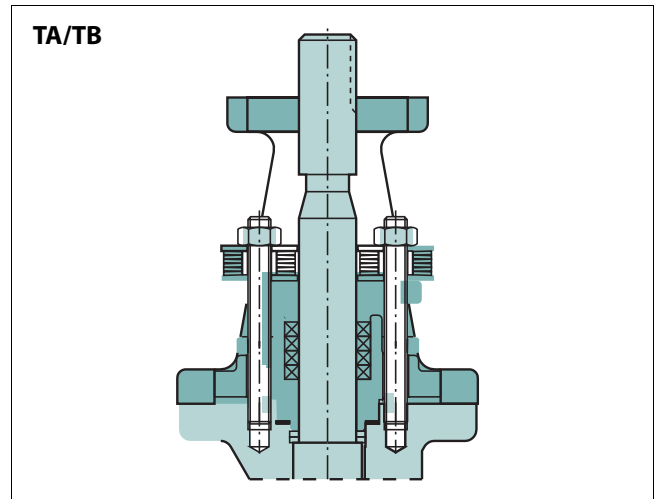

Live-loaded graphite (PTFE lubricated) construction. TA-Luft & ISO 15848-1 certified. Standard construction for high temperature applications (+250 °C to +425 °C / +482 °F to +797 °F).

**PARTS LIST\***

Part	Description	Material
1	Body	Carbon steel (WCC) / stainless steel (CF8M)
2	Insert	Stainless steel
3A	Plug	Stainless steel + cobalt based hard facing
3B	Plug with Q2 plate	Stainless steel + cobalt based hard facing
5	Stem	Stainless steel 17-4 PH Nitrated
7	Seat	Metal seat: Stainless steel XM-19/stainless steel+cobalt based hard facing Soft seat: Stainless steel + Xtreme
8	Bonnet	Carbon steel (WCC) / stainless steel (CF8M)
9	Gland	Stainless steel (CF8M)
10	Key	SS 142324
13	Stud	Carbon steel / stainless steel
14	Stud	Carbon steel / stainless steel
15	Upper bearing	Stainless steel 17-4 PH Nitrated
16	Lower bearing	Stainless steel 17-4 PH Nitrated
17	Hexagon nut	Carbon steel / stainless steel
18	Hexagon nut	Carbon steel / stainless steel
19	Identification plate	Stainless steel
63	Back seal	Graphite
66	Bonnet seal	Graphite
69	Gland packing	PTFE / graphite+PTFE
70	Thrust bearing	Cobalt based alloy
86	Flow direction arrow	Aluminium
150	Disc spring set	SIS 2324 & CrMO steel + ENP

\*The parts are not in number order since certain part has dedicated part number.

**EXPLODED VIEW**

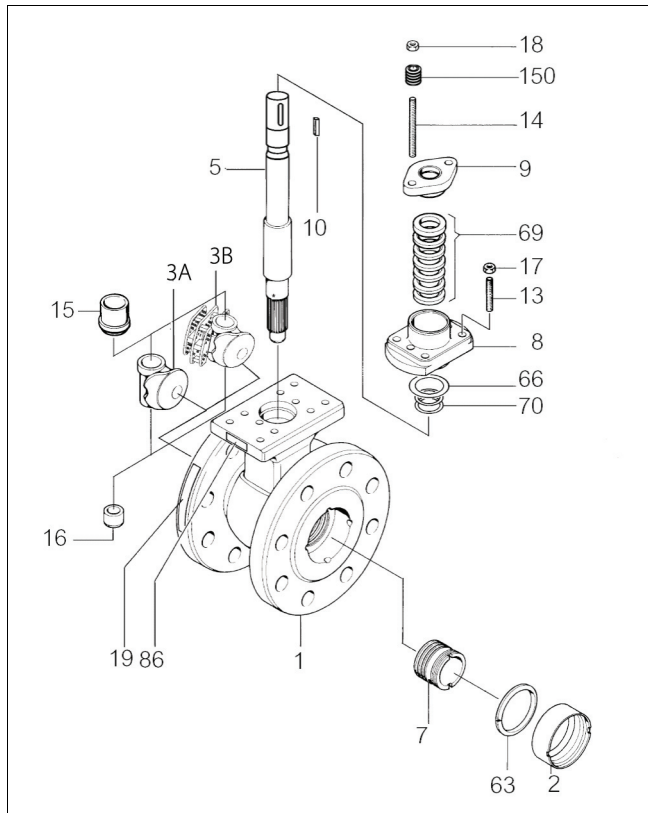

**ACTUATORS**



**Series Quadra-Powr X**  
 Type Pneumatic rotary spring-diaphragm actuator  
 Temperature range -29 to +66 °C / -20 to + 150 °F  
 Bulletin reference 6QPX21



**Series B1**  
 Type Pneumatic rotary cylinder actuator  
 Temperature range -40 to +120 °C / -40 to +248 °F  
 Bulletin reference 6B20

**POSITIONERS**



**Intelligent valve controller ND9000**  
 Input 4 - 20 mA or 0 - 100 %  
 Split range 4 - 12 mA, 12 - 20 mA  
 Temperature range -40 to + 85 °C / -40 to +185 °F  
 Communication HART, Profibus PA, FOUNDATION fieldbus  
 Bulletin reference 7ND9120



**Electropneumatic positioner, NE 700**  
 Input 4 - 20 mA, 0 - 20 mA  
 Split range 4 - 12 mA, 12 - 20 mA  
 Temperature range -25 to +85 °C / -13 to +185 °F  
 Bulletin reference 7NENP20



**Pneumatic positioner, NP 700**  
 Input 0.2 - 1 bar, 20 - 200 kPa, 3 - 15 psi  
 Split range 0.2 - 0.6 bar, 0.6 bar - 1 bar, 3 - 9 psi, 9 - 15 psi  
 Temperature range -40 to +90 °C / -40 to +194 °F  
 Bulletin reference 7NENP20

**DIMENSIONAL DRAWINGS, ACTUATOR QUADRA-POWR, DIMENSIONS IN mm (inch)**

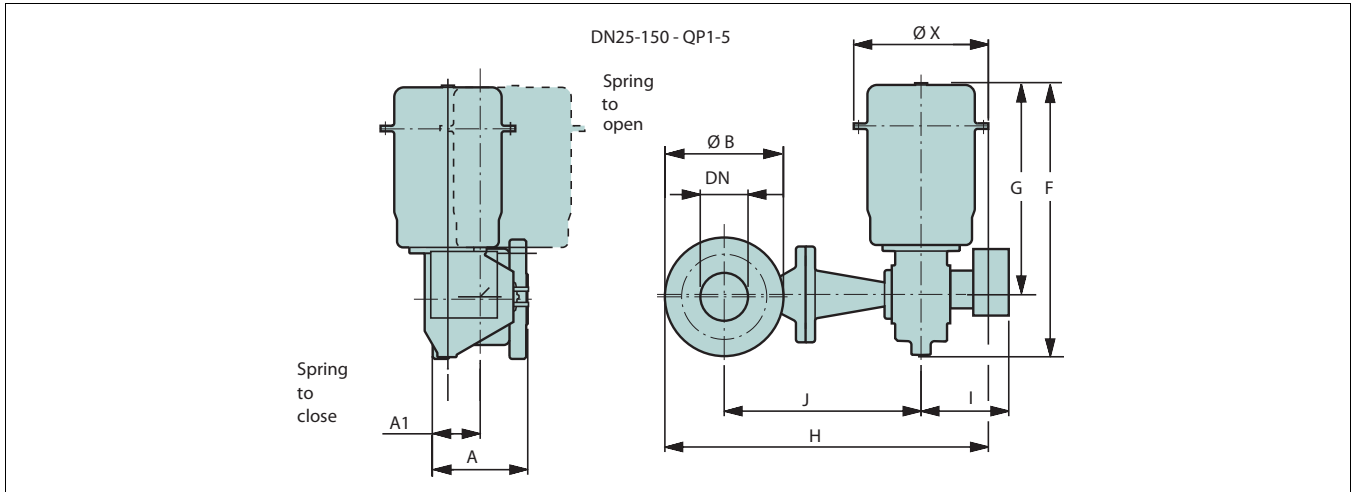

DN	Actuator size	A1	J	Jcryo	I	G	F	øX
25 (1)	QP1	51 (2.01)	235 (9.25)	464 (18.27)	205 (8.07)	280 (11.02)	332 (13.07)	213 (8.39)
25 (1)	QP2	51 (2.01)	244 (9.61)	473 (18.62)	215 (8.46)	339 (13.35)	430 (16.93)	228 (8.98)
40 (1 1/2)	QP1	57 (2.24)	250 (9.84)	479 (18.86)	205 (8.07)	280 (11.02)	332 (13.07)	213 (8.39)
40 (1 1/2)	QP2	57 (2.24)	259 (10.20)	488 (19.21)	215 (8.46)	339 (13.35)	430 (16.93)	228 (8.98)
50 (2)	QP2	62 (2.44)	269 (10.59)	482 (18.98)	215 (8.46)	339 (13.35)	430 (16.93)	228 (8.98)
50 (2)	QP3	62 (2.44)	273 (10.75)	486 (19.13)	220 (8.66)	396 (15.59)	515 (20.28)	274 (10.79)
80 (3)	QP3	82.5 (3.25)	309 (12.17)	628 (24.72)	220 (8.66)	396 (15.59)	515 (20.28)	274 (10.79)
80 (3)	QP4	82.5 (3.25)	315 (12.40)	634 (24.96)	225 (8.86)	445 (17.52)	585 (23.03)	320 (12.60)
100 (4)	QP4	97 (3.82)	387 (15.24)	676 (26.61)	225 (8.86)	445 (17.52)	585 (23.03)	320 (12.60)
100 (4)	QP5	97 (3.82)	402 (15.83)	691 (27.20)	240 (9.45)	558 (21.97)	718 (28.27)	382 (15.04)
150 (6)	QP5	114.5 (4.51)	442 (17.40)	731 (28.78)	240 (9.45)	558 (21.97)	718 (28.27)	382 (15.04)

VALVE AND ACTUATOR SIZE		Normal face-to-face, series FC			
		ASME/ISA 75.08.02			
DN	QP	A	Ø B	H	Kg / lbs
<b>ASME 150</b>					
25 (1)	1	102 (4.00)	124 (4.88)	405 (15.94)	18.5 / 41
25 (1)	2	102 (4.00)	124 (4.88)	420 (16.54)	26.5 / 59
40 (1 1/2)	1	114 (4.50)	156 (6.14)	435 (17.13)	21 / 47
40 (1 1/2)	2	114 (4.50)	156 (6.14)	455 (17.91)	29 / 64
50 (2)	2	124 (4.88)	165 (6.50)	470 (18.50)	35 / 77
50 (2)	3	124 (4.88)	165 (6.50)	495 (19.49)	51 / 113
80 (3)	3	165 (6.50)	200 (7.87)	555 (21.85)	55 / 121
80 (3)	4	165 (6.50)	200 (7.87)	580 (22.83)	77 / 170
100 (4)	4	194 (7.62)	235 (9.25)	675 (26.57)	89 / 196
100 (4)	5	194 (7.62)	235 (9.25)	720 (28.35)	138 / 304
150 (6)	5	229 (9.00)	318 (12.52)	795 (31.30)	154 / 339
<b>ASME 300</b>					
25 (1)	1	102 (4.00)	124 (4.88)	405 (15.94)	19 / 42
25 (1)	2	102 (4.00)	124 (4.88)	420 (16.54)	27 / 60
40 (1 1/2)	1	114 (4.50)	156 (6.14)	435 (17.13)	22 / 49
40 (1 1/2)	2	114 (4.50)	156 (6.14)	455 (17.91)	30 / 66
50 (2)	2	124 (4.88)	165 (6.50)	470 (18.50)	37 / 82
50 (2)	3	124 (4.88)	165 (6.50)	495 (19.49)	52 / 115
80 (3)	3	165 (6.50)	210 (8.27)	555 (21.85)	57 / 126
80 (3)	4	165 (6.50)	210 (8.27)	580 (22.83)	79 / 174
100 (4)	4	194 (7.62)	254 (10.00)	675 (26.57)	94 / 207
100 (4)	5	194 (7.62)	254 (10.00)	720 (28.35)	143 / 315
150 (6)	5	229 (9.00)	318 (12.52)	795 (31.30)	165 / 363
<b>ASME 600</b>					
25 (1)	1	102 (4.00)	124 (4.88)	405 (15.94)	19.5 / 41
25 (1)	2	102 (4.00)	124 (4.88)	420 (16.54)	27.5 / 61
40 (1 1/2)	1	114 (4.50)	156 (6.14)	435 (17.13)	22.5 / 50
40 (1 1/2)	2	114 (4.50)	156 (6.14)	455 (17.91)	30.5 / 68
50 (2)	2	124 (4.88)	165 (6.50)	470 (18.50)	38 / 84
50 (2)	3	124 (4.88)	165 (6.50)	495 (19.49)	53 / 117
80 (3)	3	165 (6.50)	210 (8.27)	555 (21.85)	59 / 130
80 (3)	4	165 (6.50)	210 (8.27)	580 (22.83)	81 / 179
100 (4)	4	194 (7.62)	274 (10.79)	685 (26.97)	99 / 218
100 (4)	5	194 (7.62)	274 (10.79)	730 (28.74)	148 / 326
150 (6)	5	229 (9.00)	356 (14.02)	815 (32.09)	180 / 396



**DIMENSIONAL DRAWINGS, OPTIONAL ACTUATOR B1C/B1J, DIMENSIONS IN mm (inch)**

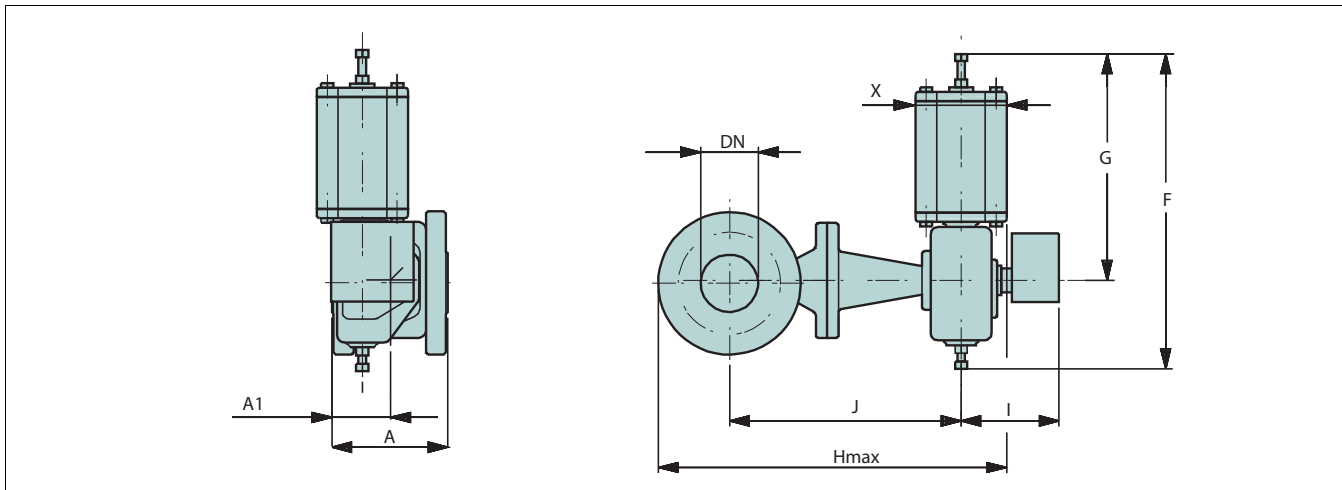

DN	B1C	A1	H max	J	Jcryo	I	G	F	X
25 (1)	6	51 (2.01)	362 (14.25)	250 (9.84)	479 (18.86)	200 (7.87)	260 (10.24)	400 (15.75)	90 (3.54)
40 (1 1/2)	6	57 (2.24)	393 (15.47)	265 (10.43)	494 (19.45)	200 (7.87)	260 (10.24)	400 (15.75)	90 (3.54)
50 (2)	6	62 (2.44)	408 (16.06)	275 (10.83)	488 (19.21)	200 (7.87)	260 (10.24)	400 (15.75)	90 (3.54)
50 (2)	9	62 (2.44)	434 (17.09)	276 (10.87)	489 (19.25)	225 (8.86)	315 (12.40)	455 (17.91)	110 (4.33)
80 (3)	9	82.5 (3.25)	492 (19.37)	312 (12.28)	631 (24.84)	225 (8.86)	315 (12.40)	455 (17.91)	110 (4.33)
80 (3)	11	82.5 (3.25)	503 (19.80)	318 (12.52)	637 (25.08)	230 (9.06)	375 (14.76)	540 (21.26)	135 (5.31)
100 (4)	11	97 (3.82)	607 (23.90)	390 (15.35)	679 (26.73)	230 (9.06)	375 (14.76)	540 (21.26)	135 (5.31)
100 (4)	13	97 (3.82)	638 (25.12)	406 (15.98)	695 (27.36)	245 (9.65)	445 (17.52)	635 (25.00)	175 (6.89)
150 (6)	13	114.5 (4.51)	719 (28.31)	446 (17.56)	735 (28.94)	245 (9.65)	445 (17.52)	635 (25.00)	175 (6.89)
150 (6)	17	114.5 (4.51)	749 (29.49)	461 (18.15)	750 (29.53)	260 (10.24)	545 (21.46)	770 (30.31)	215 (8.46)
200 (8)	17	121.5 (4.78)	889 (35.00)	565 (22.24)	836 (32.91)	260 (10.24)	545 (21.46)	770 (30.31)	215 (8.46)
200 (8)	20	121.5 (4.78)	923 (36.34)	565 (22.24)	836 (32.91)	275 (10.83)	575 (22.64)	840 (33.07)	215 (8.46)
250 (10)	20	148.5 (5.85)	1008 (39.69)	634 (24.96)	905 (35.63)	275 (10.83)	575 (22.64)	840 (33.07)	215 (8.46)
250 (10)	25	148.5 (5.85)	1066 (41.97)	634 (24.96)	905 (35.63)	310 (12.20)	710 (27.95)	1040 (40.94)	265 (10.43)
DN	B1J/B1JA	A1	H max	J	Jcryo	I	G	F	X
25 (1)	6	51 (2.01)	375.5(14.78)	251 (9.88)	480 (18.90)	225 (8.86)	368(14.49)	485(19.09)	110(4.33)
40 (1 1/2)	6	57 (2.24)	406.5(16.00)	266 (10.47)	495 (19.49)	225 (8.86)	368(14.49)	485(19.09)	110(4.33)
50 (2)	6	62 (2.44)	421.5(16.59)	276 (10.87)	489 (19.25)	225 (8.86)	368(14.49)	485(19.09)	110(4.33)
25 (1)	8	51 (2.01)	388 (15.28)	251 (9.88)	480 (18.90)	225 (8.86)	420 (16.54)	560 (22.05)	135 (5.31)
40 (1 1/2)	8	57 (2.24)	419 (16.50)	266 (10.47)	495 (19.49)	225 (8.86)	420 (16.54)	560 (22.05)	135 (5.31)
50 (2)	8	62 (2.44)	434 (17.09)	276 (10.87)	489 (19.25)	225 (8.86)	420 (16.54)	560 (22.05)	135 (5.31)
80 (3)	10	82.5 (3.25)	511 (20.12)	318 (12.52)	637 (25.08)	230 (9.06)	490 (19.29)	650 (25.59)	175 (6.89)
100 (4)	12	97 (3.82)	651 (25.63)	406 (15.98)	695 (27.36)	245 (9.65)	620 (24.41)	800 (31.50)	215 (8.46)
150 (6)	16	114.5 (4.51)	772 (30.39)	461 (18.15)	750 (29.53)	260 (10.24)	760 (29.92)	990 (38.98)	265 (10.43)
200 (8)	20	121.5 (4.78)	996 (39.21)	565 (22.24)	836 (32.91)	275 (10.83)	935 (36.81)	1200 (47.24)	395 (15.55)
250 (10)	25	148.5 (5.85)	1159 (45.63)	634 (24.96)	905 (35.63)	310 (12.20)	1200 (47.24)	1530 (60.24)	505 (19.88)

VALVE AND ACTUATOR SIZE		ASME		EN	
		Normal face-to-face, series FC		Normal face-to-face, series FC	
		ASME/ISA 75.08.02		IEC/EN 60534-3-2	
DN	B1C	A	Kg / lbs	A	Kg / lbs
25 (1)	6	102 (4.02)	12 / 27	102 (4.02)	12 / 27
40 (1 1/2)	6	114 (4.49)	16 / 36	114 (4.49)	16 / 36
50 (2)	6	124 (4.88)	23 / 51	124 (4.88)	23 / 51
50 (2)	9	124 (4.88)	28 / 62	124 (4.88)	28 / 62
80 (3)	9	165 (6.50)	34 / 75	165 (6.50)	34 / 75
80 (3)	11	165 (6.50)	40 / 88	165 (6.50)	40 / 88
100 (4)	11	194 (7.64)	54 / 119	194 (7.64)	54 / 119
100 (4)	13	194 (7.64)	70 / 154	194 (7.64)	70 / 154
150 (6)	13	229 (9.02)	94 / 207	229 (9.02)	94 / 207
150 (6)	17	229 (9.02)	117 / 258	229 (9.02)	117 / 258
200 (8)	17	243 (9.57)	175 / 385	-	-
200 (8)	20	243 (9.57)	200 / 440	-	-
250 (10)	20	297 (11.69)	230 / 506	-	-
250 (10)	25	297 (11.69)	290 / 638	-	-
DN	B1J/B1JA	A	Kg / lbs	A	Kg / lbs
25 (1)	8	102 (4.02)	25 / 55	102 (4.02)	25 / 55
40 (1 1/2)	8	114 (4.49)	28 / 62	114 (4.49)	28 / 62
50 (2)	8	124 (4.88)	35 / 77	124 (4.88)	35 / 77
80 (3)	10	165 (6.50)	54 / 119	165 (6.50)	54 / 119
100 (4)	12	194 (7.64)	97 / 214	194 (7.64)	97 / 214
150 (6)	16	229 (9.02)	163 / 359	229 (9.02)	163 / 359
200 (8)	20	243 (9.57)	310 / 682	-	-
250 (10)	25	297 (11.69)	500 / 1100	-	-

\*) Class 150 face-to-face according to class 300.

## HOW TO ORDER

1.	2.	3.	4.	5.	6.	7.	8.	9.	10.
FC	04	D	W	TA	S6	KB	SGT	D	A

Example: The following example is for a FC flanged valve, 4" size with ASME class 300 body (D), end connection style according to ASME B16.5 (W), general and fire safe construction with live loaded packing and flow-to-open flow direction (TA), CF8M body with 316SS insert, CF8M bonnet and 316SS gland (S6), CF8M plug with cobalt based hard facing and 17-4PH stem and bearing (KB), Cv-100% XM-19 seat with cobalt based hard facing and graphite back seal with PTFE V-ring and graphite bonnet seal (SGT), B8M studs and 8M nuts for stainless steel body (D), standard actuator mounting face (A).

### ASME/ISA VALVES

1. sign	Valve series & style, face-to-face length
FC	Finetrol rotary control valve, flanged face-to-face acc. to ASME/ISA 575.08.02

2. sign	Connection size
01	1"
1H	1 1/2"
02	2"
03	3"
04	4"
06	6"
08	8"
10	10"

3. sign	Pressure ratings, flanges, flange drilling
C	ASME class 150*
D	ASME class 300
F	ASME class 600

\* Flange thickness' according to ASME 300

4. sign	End connection style
W	ASME B16.5, Raised face, (Ra 3.2-6.3 / AARH 125-250)

### PN VALVES

1. sign	Valve series & style, face-to-face length
FC	Finetrol rotary control valve, flanged face-to-face acc. to IEC/EN 60534-3-2

2. sign	Size
025	25 mm
040	40 mm
050	50 mm
080	80 mm
100	100 mm
150	150 mm
200	200 mm
250	250 mm

3. sign	Pressure ratings, flanges, flange drilling
J	PN 10*
K	PN 16*
L	PN 25*
M	PN 40*
N	PN 63**
P	PN100**

\* Flange thickness according to class 300 for all sizes  
 \*\* Flange thickness according to class 600 for all sizes; DN80, 150, 200, 250 have 2 threaded flange drillings in the valve neck area  
 DN100 has all threaded flange drilling

4. sign	End connection style
C	Raised face, standard Rz 40-160 (Ra 10-40)

## ALL FINETROL VALVES

5. sign	Application and / or construction
TA	General and Fire Safe, Live loaded single packing, FTO, TA-Luft tested and certified by TÜV.
TB	General and Fire Safe, Live loaded single packing, FTC, TA-Luft tested and certified by TÜV.
QT	Q-trim FTO, Live loaded single packing
KA	Cryogenic construction, extended bonnet, FTO
KB	Cryogenic construction, extended bonnet, FTC
KQ	Cryogenic construction with Q-trim, extended bonnet, FTO

### ASME/ISA VALVES

6. sign	Body	Insert	Bonnet	Gland
S6	CF8M / 1.4408	316SS / 1.4436	CF8M / 1.4408	316SS / 1.4436
J1	WCC / 1.0619	316SS / 1.4436	WCC / 1.0619	316SS / 1.4436

## ALL FINETROL VALVES

7.	PLUG, STEM AND BEARINGS MATERIAL AND STEM TYPE			
	Plug	Coating	Stem Material / Type	Bearing
KB	CF8M / 1.4581	Cobalt based hard facing	17-4PH, Nitrated Keyway	17-4PH, Nitrated

## ALL FINETROL VALVES

8. sign	SEAT AND SEAT MATERIAL AND CONSTRUCTION				
	Seat type	Seat material	Back seal	Packings	Bonnet seal
NGT	S, Cv 100 %	6"-10": 316 (no coating)	Graphite	V-ring PTFE	Graphite
NGG	S, Cv 100 %	6"-10": 316 (no coating)	Graphite	Graphite	Graphite
MGT	R, Cv 50 %	6"-10": 316 (no coating)	Graphite	V-ring PTFE	Graphite
MGG	R, Cv 50 %	6"-10": 316 (no coating)	Graphite	Graphite	Graphite
SGT	S, Cv 100 %	1"-4": XM-19, 6"-10": 316 + cobalt based hard facing	Graphite	V-ring PTFE	Graphite
SGG	S, Cv 100 %	1"-4": XM-19, 6"-10": 316 + cobalt based hard facing	Graphite	Graphite	Graphite
RGT	R, Cv 50 %	1"-4": XM-19, 6"-10": 316 + cobalt based hard facing	Graphite	V-ring PTFE	Graphite
RGG	R, Cv 50 %	1"-4": XM-19, 6"-10": 316 + cobalt based hard facing	Graphite	Graphite	Graphite
TTT	T, Cv 100 %	316+Xtreme	PTFE	V-ring PTFE	Graphite
TTG	T, Cv 100 %	316+Xtreme	PTFE	Graphite	Graphite

9. sign	Studs	Nuts
D *	B8M	8M
F **	L7M	2HM

10. sign	Actuator mounting face
A	Standard
-	Special

\* Bolting material for stainless steel body.  
 \*\* Bolting material for carbon steel body.

## ACTUATORS, POSITIONERS

For Quadra-Powr<sup>\*</sup> actuators see bulletin 6 QPX 21  
 For B-series actuators see bulletin 6 B 20  
 For ND-positioners see bulletin 7 ND90 21  
 For NE/NP-positioners see bulletin 7 NE/NP 20.  
 Codes for Finetrol in Nelpref control valve selection software: FI - FTO, FI - FTC, Q - FI

**Metso Corporation**  
 Töölönlahdenkatu 2, PO Box 1220, 00100 Helsinki, Finland  
 Tel. +358 20 484 100

**Metso Flow Control Inc.**  
 Vanha Porvoontie 229, P.O. Box 304, FI-01301 VANTAA, Finland.  
 Tel. +358 20 483 150. Fax +358 20 483 151

[www.metso.com/valves](http://www.metso.com/valves)

Subject to change without prior notice. Product names in this bulletin are all trademarks of Metso Flow Control Inc.

