

NELES® ROTARYGLOBE CONTROL VALVE, SERIES ZX

Metso's Neles RotaryGlobe control valve is designed to control a wide range of process liquids, gases and vapors. Its reliable and rugged construction with variety of different trim choices makes the Neles RotaryGlobe an ideal choice for general, difficult and even severe service control valve applications in a wide range of industries.

The Neles RotaryGlobe valve provides excellent control accuracy with the inherent benefits of a rotary valve. The optimized design results in reliability and control stability and also reduces lifetime costs and maintenance needs.

The latest technology intelligent valve controller ensures that the control performance is in the highest class and the user-friendly software with online diagnostics enables true predictive maintenance capabilities.

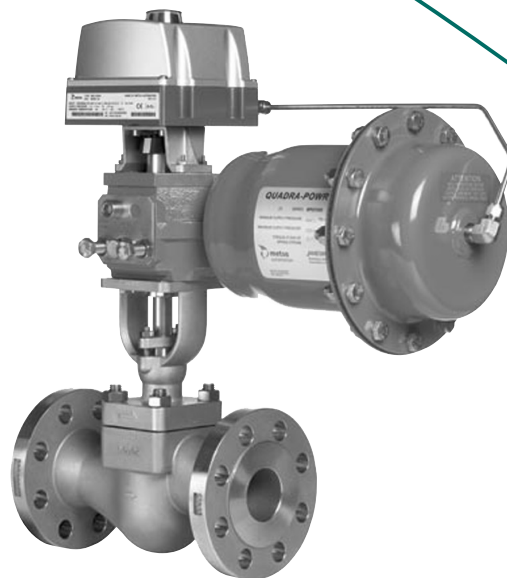

FEATURES

Construction

- The construction combines all the benefits of a linear globe valve and a rotary control valve.
- Modular design with variety of interchangeable trims selections.
- Balanced and low noise trims for higher pressure drop application.
- Wide material selection for severe service applications.
- Meets all the requirements of both ASME and EN standards.
- Compact and lightweight design.
- Free actuator mounting directions.
- Easy to size and select.
- Patent pending.

Modular and reliable design

- Modular design enables use of parts across sizes and decreases the spare part needs.
- Thrust bearing is not a wetted part and is not effected by corrosive fluids

Safety

- Fire safe tested and certified according to API 607 5th edition.
- Stem anti-blowout construction ensures safety in operation and during maintenance.
- Valve turns clockwise to close.
- Rugged one-piece-body construction minimizes potential leak paths and makes the valve insensitive to pipe stress.
- Live loaded packing as option. Economical and simple solution to reduce emissions (fulfills the ISO 15848-1 standard)

Accurate control

- Construction is inherently stable against the flow forces, resulting in stable control also with low opening angles.
- Lever-less position feedback eliminates backlash and provides ruggedness and reliability

Versatility: Wide range of applications

- Temperature limits -80 °C ... +425 °C / -112 °F ... +797 °F with the standard construction.
- Fulfills NACE requirements as option.
- Suitable for liquid, gas and vapor applications in all industry areas

Easy maintenance

- Engineered for easy maintenance
- Top entry design enables inline service
- Internal parts, Cv values and flow characteristic can be easily changed with the interchangeable trim parts.
- Valve controller with online diagnostics enables performance follow-up and predictive maintenance
- Efficient asset management with Metso FieldCare™ open architecture software and excellent networking capabilities

EXPLODED VIEW AND PARTS LIST*

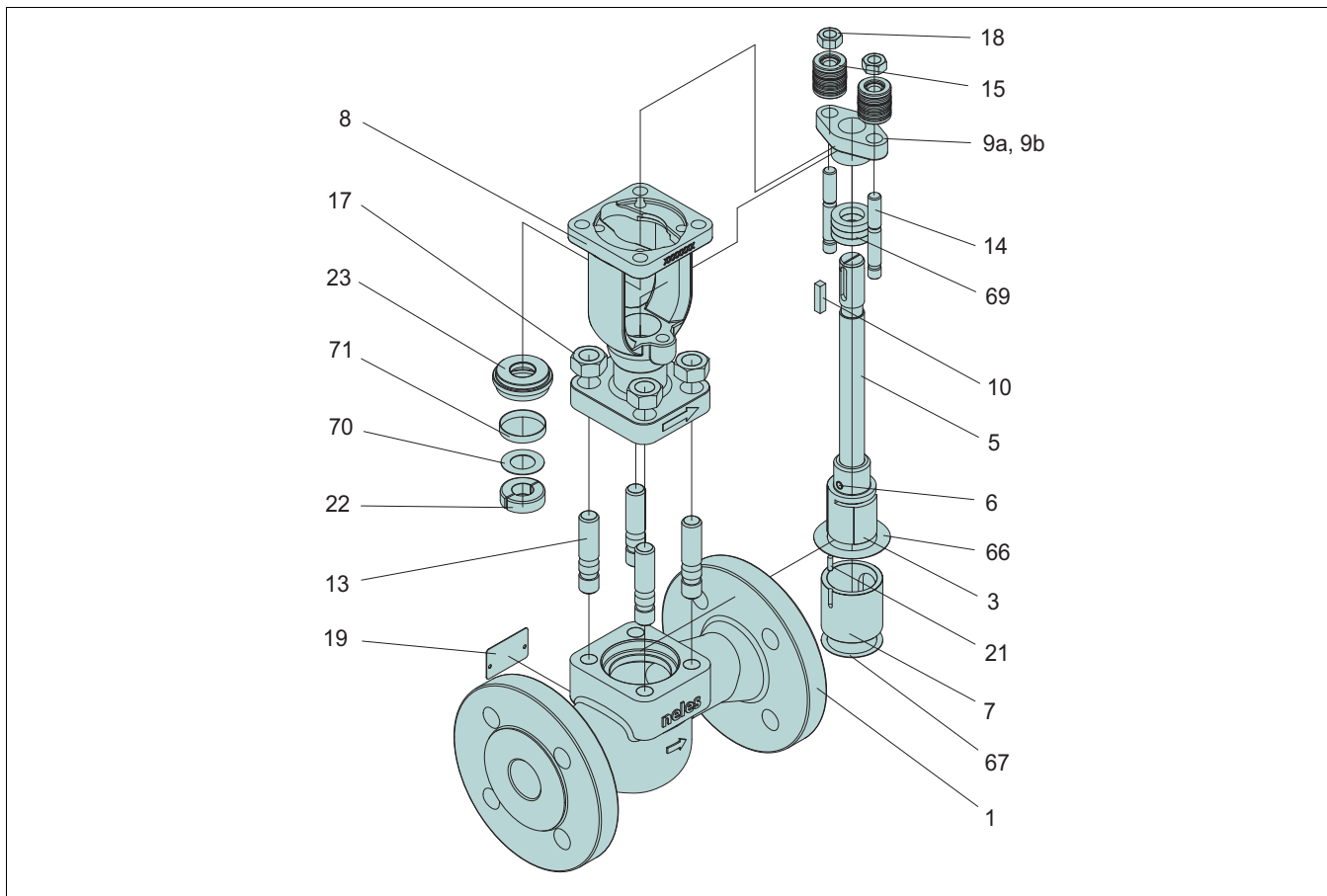

Item	Qty.	Description	Material
1	1	Body	Stainless steel CF8M/Carbon steel WCC
3	1	Plug	17-4PH + hard chrome coating
5	1	Shaft	AISI 316
6	1	Pin	AISI 316
7	1	Valve cage	Nitronic 60
8	1	Bonnet	Stainless steel CF8M/Carbon steel WCC
9 a	1	Gland	Stainless steel CF8M
9 b	1	Compression sleeve **)	Stainless steel CF8M
10	1	Key	SS 142324
13	4	Stud	A2-70
14	2	Stud	A2-70
15	2	Disc spring set	SIS 2324 & CrMO steel + ENP
17	4	Hexagon nut	A2-70
18	2	Hexagon nut	A2-70
19	1	Identification plate	AISI 304
21	1	Pin	AISI 316
22	2	Thrust bearing	AISI 316
23	1	Support ring	AISI 316
66	1	Sheet ring	Graphite
67	1	Sheet ring	Graphite
69	1	Packing rings	PTFE/Graphite
70	1	Bearing strip	PTFE + AISI 316
71	1	Bearing strip	PTFE + AISI 316

*) The parts are not in number order since certain part has dedicated part number.

***) sizes 3" and 4" only

TECHNICAL SPECIFICATION

Product type

- Flanged, RotaryGlobe control valve

Pressure ratings

- ASME Class 150 - 1500
- PN10-PN100

Size range

- 1/2" - 4" / DN15 - 100

Temperature range

- -80 °C... +425 °C / -112 °F...+797 °F

Face-to face

- ANSI/ISA 75.08.01 - 2002, ASME class 150 - 600
- ANSI/ISA 75.08.06 - 2002 (long dimension), ASME class 900 - 1500

Tightness classification

- IEC 60534-4 Class III - IV (water)

Standard materials

- CF8M and WCC

Optional materials

- Hastelloy C
- Alloy 20
- WC6
- CF8

Trim for cavitation and noise reduction

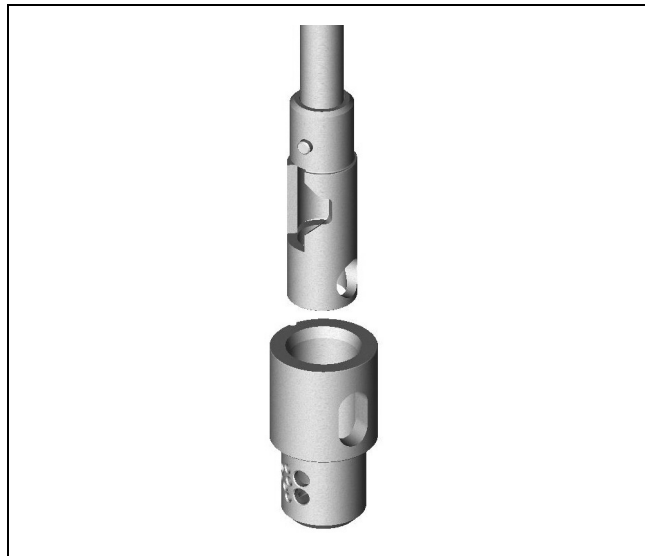

- Liquid cavitation and aerodynamic noise problems can be solved with the patented Q-Trim™ valve trim. This design is based on pressure staging and flow stream division.

ACTUATORS AND POSITIONERS

ACTUATORS

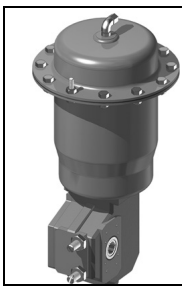

Series Quadra-Powr X

Type	Pneumatic rotary spring-diaphragm actuator
Temperature range	-29 to +66 °C / -20 to + 150 °F
Bulletin reference	6QPX20



Series B1

Type	Pneumatic rotary cylinder actuator
Temperature range	-40 to +120 °C / -40 to +248 °F
Bulletin reference	6B20, 6B21

POSITIONERS



Intelligent valve controller ND9000

Input	4 - 20 mA or 0 - 100 %
Split range	4 - 12 mA, 12 - 20 mA
Temperature range	-40 to +85 °C / -40 to +185 °F
Communication	HART, Profibus PA, FOUNDATION fieldBus
Bulletin reference	7ND9120

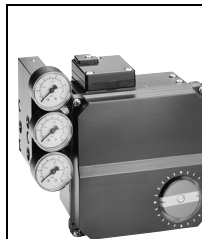

Electropneumatic positioner, NE 700

Input	4 - 20 mA, 0 - 20 mA
Split range	4 - 12 mA, 12 - 20 mA
Temperature range	-25 to +85 °C / -13 to +185 °F
Bulletin reference	7NENP20



Pneumatic positioner, NP 700

Input	0.2 - 1 bar, 20 - 200 kPa, 3 - 15 psi
Split range	0.2 - 0.6 bar, 0.6 bar - 1 bar, 3 - 9 psi, 9 - 15 psi
Temperature range	-40 to +90 °C / -40 to +194 °F
Bulletin reference	7NENP20

PRESSURE/TEMPERATURE RATINGS

A 351 Gr. CF8M

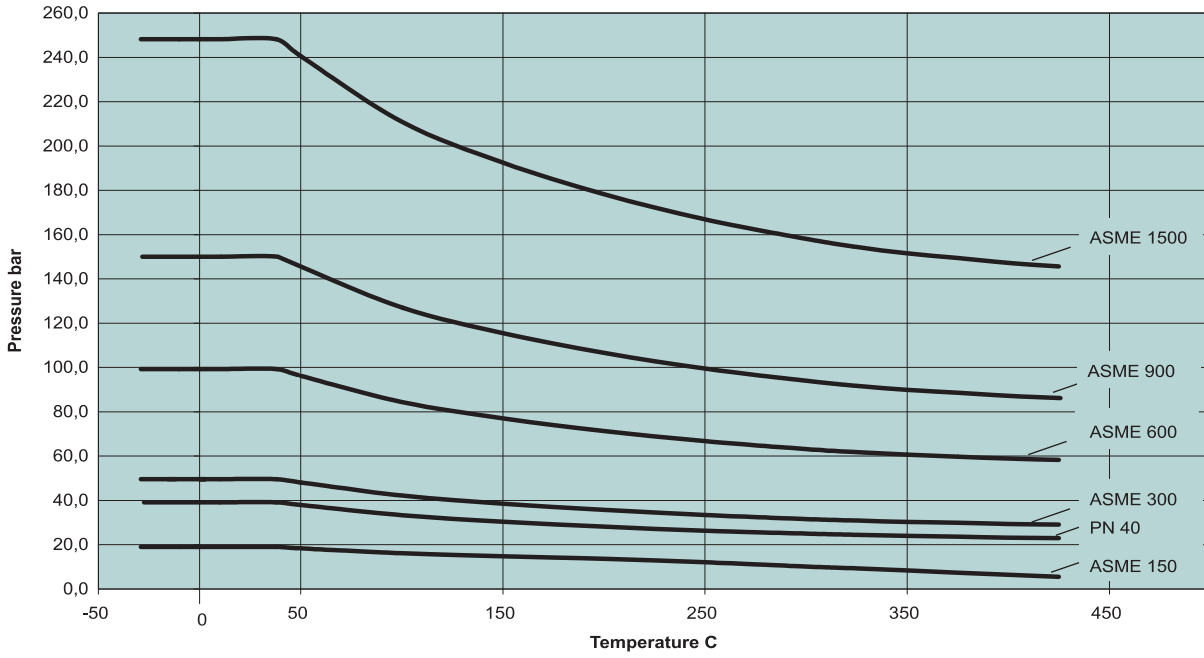

A 216 Gr.WCC

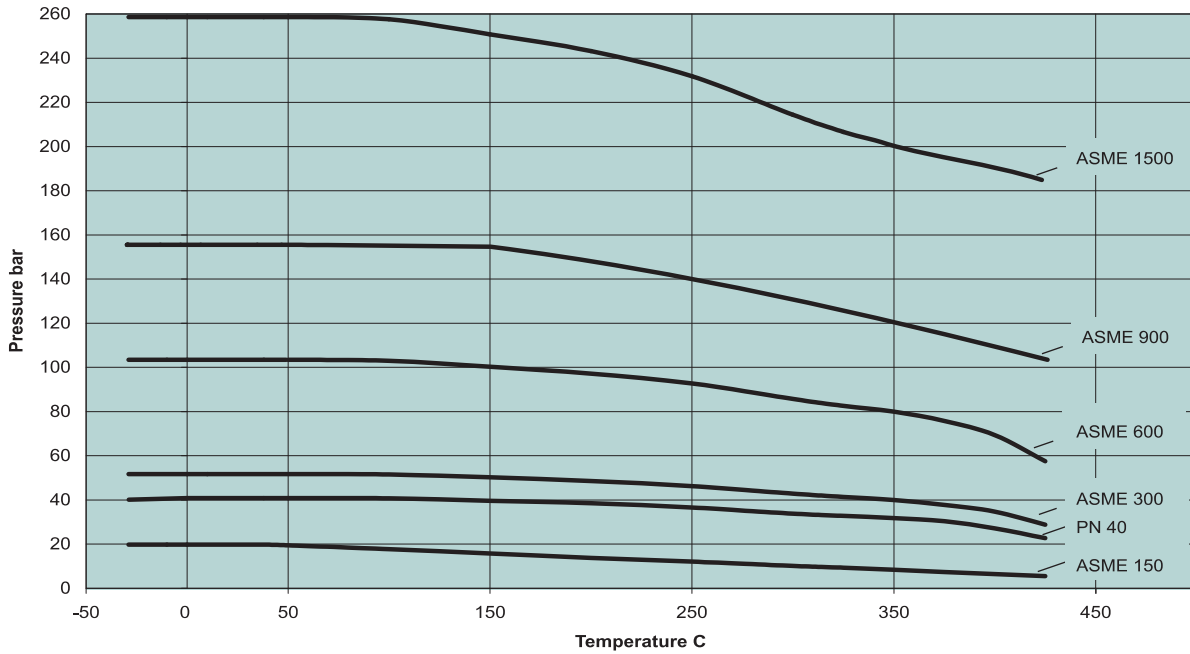

Actuator selection and maximum differential pressures

Safety factor 1.1		Shut-off pressure, bar																					
		Supply pressure 4 barG min																					
		B1C6			B1C9			B1C11			B1C13			B1C17			B1C20			B1C25			
Actuator Class	150-600	900	1500	150-600	900	1500	150-600	900	1500	150-600	900	1500	150-600	900	1500	150-600	900	1500	150-600	900	1500		
Size (mm/inch)																							
015 / 1/2"	<100	N/A			N/A			N/A			N/A			N/A			N/A			N/A			
020 / 3/4"	<100	N/A			N/A			N/A			N/A			N/A			N/A			N/A			
025 / 1"	<100	N/A	<250		N/A			N/A			N/A			N/A			N/A			N/A			
040 / 1-1/2"	<70	N/A		<100	N/A			N/A	<245		N/A	<250		N/A			N/A			N/A			
050 / 2"	<70	N/A		<100	N/A			N/A	<245		N/A	<250		N/A			N/A			N/A			
080 / 3"								<85			<100	<125	<95			<150	<250						
100 / 4"											<65				<100	<80	<60			<110	<90	<150	<230

		Shut-off pressure, bar																					
		Supply pressure 3.5 barG min																					
		B1J6			B1J8			B1J10			B1J12			B1J16			B1J20			B1J25			
Actuator Class	150-600	900	1500	150-600	900	1500	150-600	900	1500	150-600	900	1500	150-600	900	1500	150-600	900	1500	150-600	900	1500		
Size (mm/inch)																							
015 / 1/2"	<100	N/A		<100	N/A			N/A			N/A			N/A			N/A			N/A			
020 / 3/4"	<100	N/A		<100	N/A			N/A			N/A			N/A			N/A			N/A			
025 / 1"	<100	N/A	<220	<100	N/A	<250		N/A			N/A			N/A			N/A			N/A			
040 / 1-1/2"	<60	N/A		<75	N/A		<100	N/A	<155		N/A	<250		N/A			N/A			N/A			
050 / 2"	<60	N/A		<75	N/A		<100	N/A	<155		N/A	<250		N/A			N/A			N/A			
080 / 3"							<45				<100	<70	<40			<150	<150			<250			
100 / 4"											<35				<90	<45	<25	<100	<120	<100		<150	<250

		Shut-off pressure, bar																				
		Supply pressure 3.5 barG min																				
		Spring to close																				
Actuator Class	QPX1C			QPX2C			QPX3C			QPX4C			QPX5C									
Size (mm/inch)	150-600	900	1500	150-600	900	1500	150-600	900	1500	150-600	900	1500	150-600	900	1500	150-600	900	1500				
015 / 1/2"	<100		N/A					N/A			N/A			N/A			N/A			N/A		
020 / 3/4"	<100		N/A					N/A			N/A			N/A			N/A			N/A		
025 / 1"	<100	N/A						N/A	<250		N/A			N/A			N/A			N/A		
040 / 1-1/2"		N/A		<80	N/A			N/A	<250		N/A			N/A	<250			N/A		N/A		
050 / 2"		N/A		<80	N/A			N/A	<250		N/A			N/A	<250			N/A		N/A		
080 / 3"														<100							<150	<145
100 / 4"																				<85		

		Shut-off pressure, bar																				
		Supply pressure 3.5 barG min																				
		Spring to open																				
Actuator Class	B1JA6			B1JA8			B1JA10			B1JA12			B1JA16			B1JA20			B1JA25			
Size (mm/inch)	150-600	900	1500	150-600	900	1500	150-600	900	1500	150-600	900	1500	150-600	900	1500	150-600	900	1500	150-600	900	1500	
015 / 1/2"	<100			<100	N/A			N/A			N/A			N/A			N/A			N/A		
020 / 3/4"	<100			<100	N/A			N/A			N/A			N/A			N/A			N/A		
025 / 1"	<100		<120	<100	N/A	<180		N/A	<250		N/A			N/A			N/A			N/A		
040 / 1-1/2"	<30			<50	N/A		<100	N/A	<110		N/A	<225		N/A			N/A			N/A		
050 / 2"	<30			<50	N/A		<100	N/A	<110		N/A	<225		N/A			N/A			N/A		
080 / 3"							<25			<75	<30		<100	<110	<80		<150	<245				
100 / 4"										<20			<55	<20		<100	<80	<60			<150	<170

		Shut-off pressure, bar																				
		Supply pressure 3.5 barG min																				
		Spring to open																				
Actuator Class	QPX1C			QPX2C			QPX3C			QPX4C			QPX5C									
Size (mm/inch)	150-600	900	1500	150-600	900	1500	150-600	900	1500	150-600	900	1500	150-600	900	1500	150-600	900	1500				
015 / 1/2"	<100		N/A					N/A			N/A			N/A			N/A			N/A		
020 / 3/4"	<100		N/A					N/A			N/A			N/A			N/A			N/A		
025 / 1"	<65	N/A		<100	N/A	<135		N/A	<250		N/A			N/A			N/A			N/A		
040 / 1-1/2"		N/A		<35	N/A		<80	N/A		<100	N/A	<165		N/A			N/A			N/A	<250	
050 / 2"		N/A		<35	N/A		<80	N/A		<100	N/A	<165		N/A			N/A			N/A	<250	
080 / 3"														<50						<100	<70	<40
100 / 4"																				<35		

DIMENSIONS

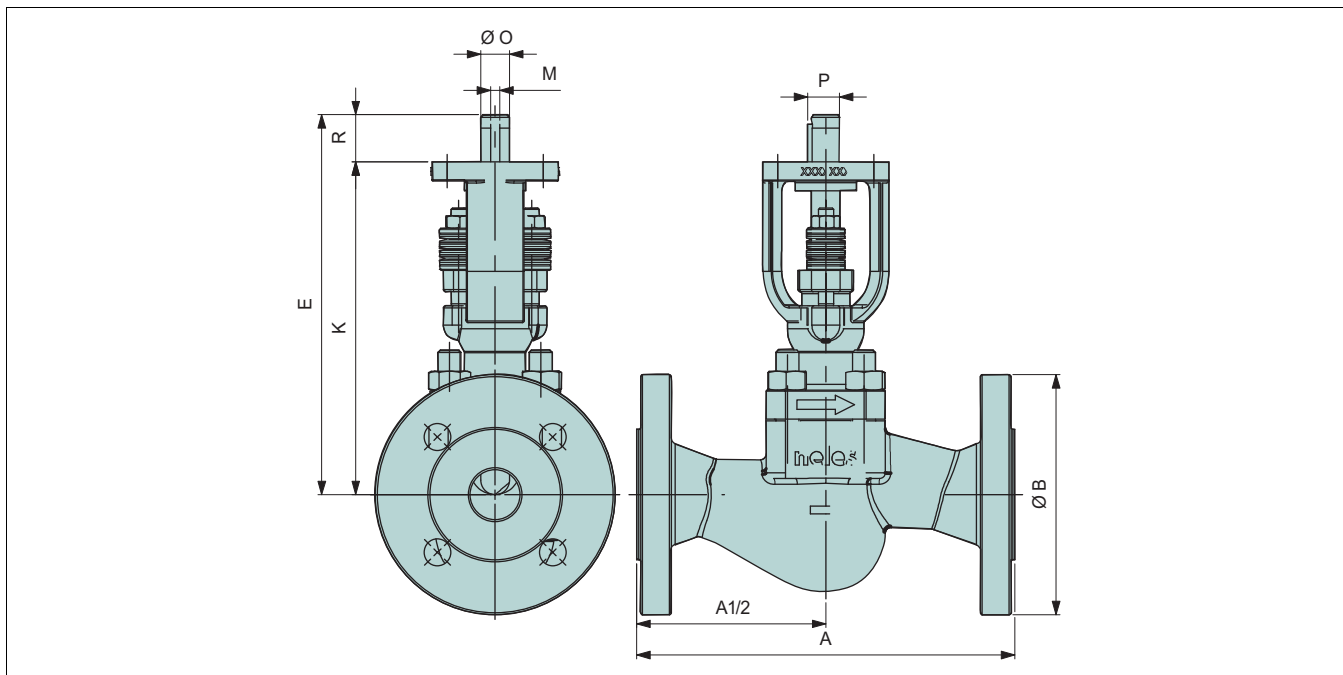

Class 150

TYPE	SIZE	ISO FLANGE	DIMENSIONS, mm (inch)								kg (lbs)
			A	ØB	E	K	M	ØO	P	R	
ZXC	1/2	F05, F07	184 (7.24)	90 (3.54)	199 (7.83)	174 (6.85)	4.76 (0.19)	15 (0.59)	17 (0.67)	25 (0.98)	4.6 (10.1)
	3/4	F05, F07	184 (7.24)	100 (3.94)	199 (7.83)	174 (6.85)	4.76 (0.19)	15 (0.59)	17 (0.67)	25 (0.98)	5.0 (11.0)
	1	F05, F07	184 (7.24)	110 (4.33)	199 (7.83)	174 (6.85)	4.76 (0.19)	15 (0.59)	17 (0.67)	25 (0.98)	5.4 (11.9)
	1 1/2	F07, F10	222 (8.74)	125 (4.92)	236 (9.29)	201 (7.91)	4.76 (0.19)	20 (0.79)	22.2 (0.87)	35 (1.38)	11.2 (24.7)
	2	F07, F10	254 (10.00)	150 (5.91)	236 (9.29)	201 (7.91)	4.76 (0.19)	20 (0.79)	22.2 (0.87)	35 (1.38)	13.2 (29.2)
	3	F10, F12	298 (11.73)	190 (7.48)	382 (15.03)	331 (13.02)	6.35 (0.25)	30 (1.18)	32.9 (1.29)	51 (2.01)	41.0 (90.0)
4	F12, F14	352 (13.85)	230 (9.05)	436 (17.16)	368 (14.48)	9.53 (0.37)	40 (1.57)	44.2 (1.74)	68 (2.68)	65.9 (144.7)	

Class 300

TYPE	SIZE	ISO FLANGE	DIMENSIONS, mm (inch)								kg (lbs)
			A	ØB	E	K	M	ØO	P	R	
ZXD ZXM	1/2	F05, F07	190 (7.48)	95 (3.74)	199 (7.83)	174 (6.85)	4.76 (0.19)	15 (0.59)	17 (0.67)	25 (0.98)	5.6 (12.3)
	3/4	F05, F07	194 (7.64)	115 (4.53)	199 (7.83)	174 (6.85)	4.76 (0.19)	15 (0.59)	17 (0.67)	25 (0.98)	6.8 (14.9)
	1	F05, F07	197 (7.76)	125 (4.92)	199 (7.83)	174 (6.85)	4.76 (0.19)	15 (0.59)	17 (0.67)	25 (0.98)	7.5 (16.5)
	1 1/2	F07, F10	235 (9.25)	155 (6.10)	236 (9.29)	201 (7.91)	4.76 (0.19)	20 (0.79)	22.2 (0.87)	35 (1.38)	15 (32.9)
	2	F07, F10	267 (10.51)	165 (6.50)	236 (9.29)	201 (7.91)	4.76 (0.19)	20 (0.79)	22.2 (0.87)	35 (1.38)	16.9 (37.2)
	3	F10, F12	318 (12.52)	210 (8.26)	382 (15.03)	331 (13.02)	6.35 (0.25)	30 (1.18)	32.9 (1.29)	51 (2.01)	45.9 (100.8)
4	F12, F14	368 (14.49)	255 (10.03)	436 (17.16)	368 (14.48)	9.53 (0.37)	40 (1.57)	44.2 (1.74)	68 (2.68)	75.6 (166.0)	

Class 600

TYPE	SIZE	ISO FLANGE	DIMENSIONS, mm (inch)								kg (lbs)
			A	ØB	E	K	M	ØO	P	R	
ZXD ZXM ZXP	1/2	F05, F07	203 (7.99)	95 (3.74)	199 (7.83)	174 (6.85)	4.76 (0.19)	15 (0.59)	17 (0.67)	25 (0.98)	5.7 (12.6)
	3/4	F05, F07	206 (8.11)	115 (4.53)	199 (7.83)	174 (6.85)	4.76 (0.19)	15 (0.59)	17 (0.67)	25 (0.98)	6.7 (14.8)
	1	F05, F07	210 (8.27)	125 (4.92)	199 (7.83)	174 (6.85)	4.76 (0.19)	15 (0.59)	17 (0.67)	25 (0.98)	7.6 (16.7)
	1 1/2	F07, F10	251 (9.88)	155 (6.10)	236 (9.29)	201 (7.91)	4.76 (0.19)	20 (0.79)	22.2 (0.87)	35 (1.38)	15.8 (34.8)
	2	F07, F10	286 (11.26)	165 (6.50)	236 (9.29)	201 (7.91)	4.76 (0.19)	20 (0.79)	22.2 (0.87)	35 (1.38)	18.0 (39.7)
	3	F10, F12	337 (13.26)	210 (8.26)	382 (15.03)	331 (13.02)	6.35 (0.25)	30 (1.18)	32.9 (1.29)	51 (2.01)	50.5 (110.9)
4	F12, F14	394 (15.5)	275 (10.82)	436 (17.16)	368 (14.48)	9.53 (0.37)	40 (1.57)	44.2 (1.74)	68 (2.68)	87.1 (191.3)	

Class 900

TYPE	SIZE	ISO FLANGE	DIMENSIONS, mm (inch)								kg (lbs)
			A	ØB	E	K	M	ØO	P	R	
ZXC	3	F12, F14	441 (17.36)	240 (9.45)	473 (18.62)	405 (15.94)	9.53 (0.38)	40 (1.57)	44.2 (1.74)	68 (2.68)	93.9 (207.0)
	4	F14, F16	511 (20.12)	290 (11.42)	567 (22.32)	477 (18.78)	12.70 (0.50)	50 (1.97)	55.5 (2.19)	90 (3.54)	160 (351.4)

Class 1500

TYPE	SIZE	ISO FLANGE	DIMENSIONS, mm (inch)								kg (lbs)
			A	ØB	E	K	M	ØO	P	R	
ZXH	1	F07, F10	292 (11.50)	150 (5.91)	264 (10.39)	229 (9.02)	4.76 (0.19)	20 (0.79)	22.2 (0.87)	35 (1.38)	23.5 (51.8)
	1 1/2	F10, F12	333 (13.11)	180 (7.09)	373 (14.69)	327 (12.87)	6.35 (0.25)	25 (0.98)	27.8 (1.09)	46 (1.81)	38.0 (83.7)
	2	F10, F12	375 (14.76)	215 (8.46)	373 (14.69)	327 (12.87)	6.35 (0.25)	25 (0.98)	27.8 (1.09)	46 (1.81)	49.2 (108.4)
	3	F12, F14	460 (18.11)	265 (10.43)	473 (18.62)	405 (15.94)	9.53 (0.38)	40 (1.57)	44.2 (1.74)	68 (2.68)	105 (230.6)
4	F14, F16	530 (20.87)	310 (12.20)	567 (22.32)	477 (18.78)	12.70 (0.50)	50 (1.97)	55.5 (2.19)	90 (3.54)	174 (382.1)	

Dimensions, QPX actuators

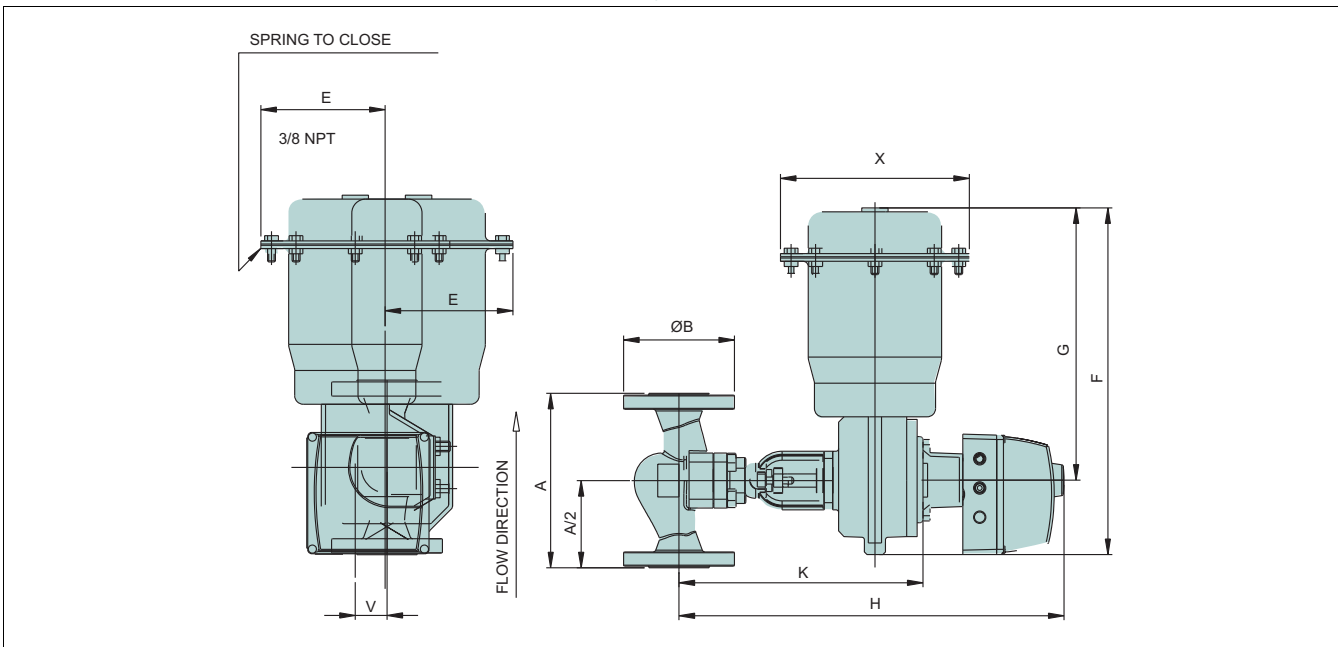

Class 150

TYPE	SIZE	ACTUATOR	ISO FLANGE	DIMENSIONS, mm (inch)								kg (lbs)	
				A	ØB	E	F	G	H	K	V		X
ZXC	1/2	QPX1C	F05	184 (7.24)	90 (3.54)	142 (5.59)	338 (13.31)	330 (12.99)	430 (16.93)	271 (10.67)	36 (1.42)	197 (7.76)	17.9 (39.5)
	3/4	QPX1C	F05	184 (7.24)	100 (3.94)	142 (5.59)	338 (13.31)	330 (12.99)	430 (16.93)	271 (10.67)	36 (1.42)	197 (7.76)	18.3 (40.3)
	1	QPX1C	F05	184 (7.24)	110 (4.33)	142 (5.59)	338 (13.31)	330 (12.99)	430 (16.93)	271 (10.67)	36 (1.42)	197 (7.76)	18.7 (41.0)
	1 1/2	QPX2C	F07	222 (8.74)	125 (4.92)	156 (6.14)	430 (16.93)	389 (15.31)	464 (18.27)	305 (12.01)	42 (1.65)	228 (8.98)	32.5 (71.6)
	2	QPX2C	F07	254 (10.00)	150 (5.91)	156 (6.14)	430 (16.93)	389 (15.31)	464 (18.27)	305 (12.01)	42 (1.65)	228 (8.98)	34.4 (75.8)
	3	QPX4C	F10	298 (11.73)	190 (7.48)	228 (8.98)	592 (23.31)	452 (17.8)	612 (24.1)	453 (17.83)	68 (2.68)	320 (12.6)	83 (182.6)
4	QPX5C	F12	352 (13.85)	230 (9.05)	276 (10.87)	721 (28.39)	561 (22.09)	681 (26.81)	522 (20.55)	85 (3.35)	382 (15.04)	170 (374)	

Class 300

TYPE	SIZE	ACTUATOR	ISO FLANGE	DIMENSIONS, mm (inch)								kg (lbs)	
				A	ØB	E	F	G	H	K	V		X
ZXD ZXM	1/2	QPX1C	F05	190 (7.48)	95 (3.74)	142 (5.59)	338 (13.31)	330 (12.99)	430 (16.93)	271 (10.67)	36 (1.42)	197 (7.76)	18.6 (41.0)
	3/4	QPX1C	F05	194 (7.64)	115 (4.53)	142 (5.59)	338 (13.31)	330 (12.99)	430 (16.93)	271 (10.67)	36 (1.42)	197 (7.76)	19.8 (43.7)
	1	QPX1C	F05	197 (7.76)	125 (4.92)	142 (5.59)	338 (13.31)	330 (12.99)	430 (16.93)	271 (10.67)	36 (1.42)	197 (7.76)	20.5 (45.2)
		QPX2C	F07	235 (9.25)	155 (6.10)	156 (6.14)	430 (16.93)	389 (15.31)	464 (18.27)	305 (12.01)	42 (1.65)	228 (8.98)	36.0 (79.4)
	1 1/2	QPX3C	F07	235 (9.25)	155 (6.10)	190 (7.48)	520 (20.47)	446 (17.56)	472 (18.58)	313 (12.32)	53 (2.09)	274 (10.79)	50.0 (110.2)
		QPX2C	F07	267 (10.51)	165 (6.50)	156 (6.14)	430 (16.93)	389 (15.31)	464 (18.27)	305 (12.01)	42 (1.65)	228 (8.98)	37.9 (83.2)
	2	QPX3C	F07	267 (10.51)	165 (6.50)	190 (7.48)	520 (20.47)	446 (17.56)	472 (18.58)	313 (12.32)	53 (2.09)	274 (10.79)	51.9 (114.4)
		QPX4C	F10	318 (12.52)	210 (8.26)	228 (8.98)	592 (23.31)	452 (17.8)	612 (24.1)	453 (17.83)	68 (2.68)	320 (12.6)	87.9 (193.4)
	3	QPX4C	F10	318 (12.52)	210 (8.26)	228 (8.98)	592 (23.31)	452 (17.8)	612 (24.1)	453 (17.83)	68 (2.68)	320 (12.6)	87.9 (193.4)
	4	QPX5C	F12	368 (14.49)	255 (10.03)	276 (10.87)	721 (28.39)	561 (22.09)	681 (26.81)	522 (20.55)	85 (3.35)	382 (15.04)	178 (391.6)

Class 600

TYPE	SIZE	ACTUATOR	ISO FLANGE	DIMENSIONS, mm (inch)								kg (lbs)	
				A	ØB	E	F	G	H	K	V		X
ZXF ZXN ZXP	1/2	QPX1C	F05	203 (7.99)	95 (3.74)	142 (5.59)	338 (13.31)	330 (12.99)	430 (16.93)	271 (10.67)	36 (1.42)	197 (7.76)	18.7 (41.0)
	3/4	QPX1C	F05	206 (8.11)	115 (4.53)	142 (5.59)	338 (13.31)	330 (12.99)	430 (16.93)	271 (10.67)	36 (1.42)	197 (7.76)	19.7 (43.4)
	1	QPX1C	F05	210 (8.27)	125 (4.92)	142 (5.59)	338 (13.31)	330 (12.99)	430 (16.93)	271 (10.67)	36 (1.42)	197 (7.76)	20.6 (45.4)
		QPX2C	F07	210 (8.27)	125 (4.92)	156 (6.14)	430 (16.93)	389 (15.31)	437 (17.20)	278 (10.94)	42 (1.65)	228 (8.98)	28.6 (63.1)
	1 1/2	QPX2C	F07	251 (9.88)	155 (6.10)	156 (6.14)	430 (16.93)	389 (15.31)	464 (18.27)	305 (12.01)	42 (1.65)	228 (8.98)	36.8 (81.1)
		QPX3C	F07	251 (9.88)	155 (6.10)	190 (7.48)	520 (20.47)	446 (17.56)	472 (18.58)	313 (12.32)	53 (2.09)	274 (10.79)	50.8 (112.0)
	2	QPX2C	F07	286 (11.26)	165 (6.50)	156 (6.14)	430 (16.93)	389 (15.31)	464 (18.27)	305 (12.01)	42 (1.65)	228 (8.98)	39.0 (86.0)
		QPX3C	F07	286 (11.26)	165 (6.50)	190 (7.48)	520 (20.47)	446 (17.56)	472 (18.58)	313 (12.32)	53 (2.09)	274 (10.79)	53.0 (116.8)
	3	QPX4C	F10	337 (13.26)	210 (8.26)	228 (8.98)	592 (23.31)	452 (17.8)	612 (24.1)	453 (17.83)	68 (2.68)	320 (12.6)	96.9 (213.2)
	4	QPX5C	F12	394 (15.5)	275 (10.82)	276 (10.87)	721 (28.39)	561 (22.09)	681 (26.81)	522 (20.55)	85 (3.35)	382 (15.04)	184.5 (405.9)

Class 900

Type	SIZE	ACTUATOR	ISO FLANGE	DIMENSIONS, mm (inch)								kg (lbs)	
				A	ØB	E	F	G	H	K	V		X
ZXG	3	QPX5C	F12	441 (17.36)	240 (9.45)	276 (10.87)	768 (30.24)	608 (23.94)	738 (29.06)	572 (22.52)	85 (3.35)	382 (15.04)	207.9 (458.3)

Class 1500

Type	SIZE	ACTUATOR	ISO FLANGE	DIMENSIONS, mm (inch)								kg (lbs)	
				A	ØB	E	F	G	H	K	V		X
ZXH	1	QPX2C	F07	292 (11.50)	150 (5.91)	156 (6.14)	430 (16.93)	389 (15.31)	492 (19.37)	333 (13.11)	42 (1.65)	228 (8.98)	44.8 (98.8)
	1 1/2	QPX4C	F10	333 (13.11)	180 (7.09)	228 (8.98)	592 (23.31)	495 (19.49)	609 (23.98)	450 (17.72)	68 (2.68)	320 (12.60)	93.5 (206.1)
	2	QPX4C	F10	375 (14.76)	215 (8.46)	228 (8.98)	592 (23.31)	495 (19.49)	609 (23.98)	450 (17.72)	68 (2.68)	320 (12.60)	104.7 (230.8)
	3	QPX5C	F12	460 (18.11)	265 (10.43)	276 (10.87)	768 (30.24)	608 (23.94)	738 (29.06)	572 (22.52)	85 (3.35)	382 (15.04)	218.9 (482.6)

Dimensions, B1C & B1J_ actuators

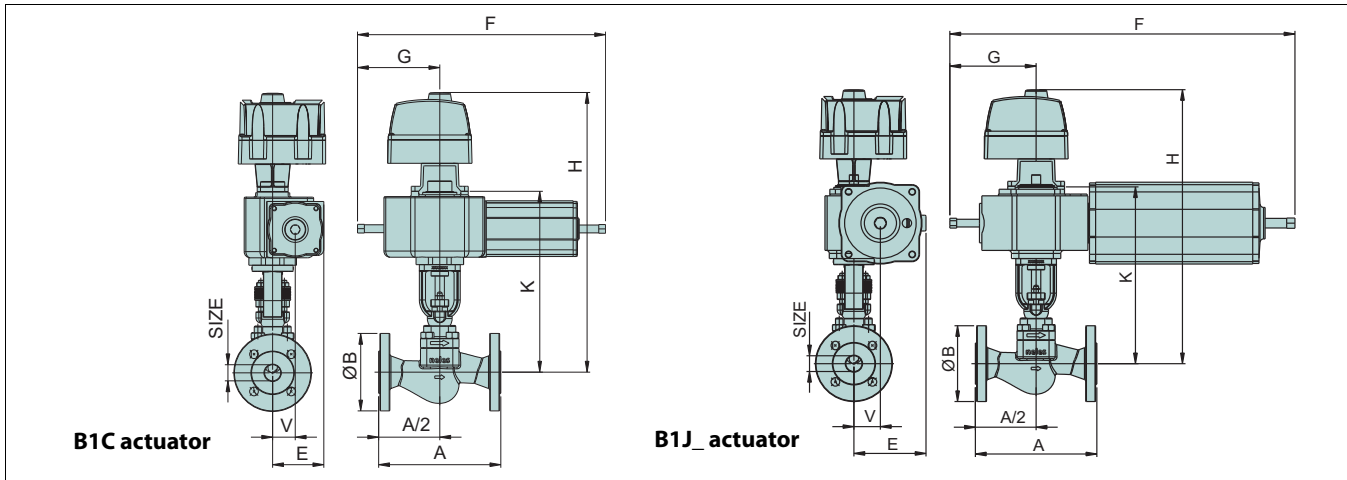

Class 150

Type	SIZE	ACTUATOR	ISO FLANGE	DIMENSIONS, mm (inch)							kg (lbs)	
				A	ØB	E	F	G	H	K		V
ZXC	1/2	B1C6	F07	184 (7.24)	90 (3.54)	83 (3.27)	395 (15.55)	125 (4.92)	451 (17.76)	292 (11.50)	36 (1.42)	11.1 (24.6)
	3/4	B1C6	F07	184 (7.24)	100 (3.94)	83 (3.27)	395 (15.55)	125 (4.92)	451 (17.76)	292 (11.50)	36 (1.42)	11.5 (25.3)
	1	B1C6	F07	184 (7.24)	110 (4.33)	83 (3.27)	395 (15.55)	125 (4.92)	451 (17.76)	292 (11.50)	36 (1.42)	11.9 (26.2)
	1 1/2	B1C6	F07	222 (8.74)	125 (4.92)	83 (3.27)	395 (15.55)	125 (4.92)	478 (18.82)	319 (12.56)	36 (1.42)	17.7 (39.0)
	2	B1C6	F07	254 (10.00)	150 (5.91)	83 (3.27)	395 (15.55)	125 (4.92)	478 (18.82)	319 (12.56)	36 (1.42)	19.7 (43.3)
		B1C11	F10	298 (11.73)	190 (7.48)	124 (4.88)	535 (21.06)	160 (6.30)	644 (25.35)	485 (19.10)	51 (2.01)	46 (101.2)
	3	B1C13	F12	352 (13.85)	230 (9.05)	155 (6.10)	640 (25.20)	195 (7.68)	690 (27.17)	521 (20.51)	65 (2.56)	61.2 (134.6)
		B1C13	F12	352 (13.85)	230 (9.05)	155 (6.10)	640 (25.20)	195 (7.68)	727 (28.62)	558 (21.97)	65 (2.56)	94.2 (207.2)
4	B1C17	F14	352 (13.85)	230 (9.05)	186 (7.32)	785 (30.91)	230 (9.06)	756 (29.76)	590 (23.23)	78 (3.07)	121.7 (267.7)	

Class 300

Type	SIZE	ACTUATOR	ISO FLANGE	DIMENSIONS, mm (inch)							kg (lbs)	
				A	ØB	E	F	G	H	K		V
ZXD, ZXM	1/2	B1C6	F07	190 (7.48)	95 (3.74)	83 (3.27)	395 (15.55)	125 (4.92)	451 (17.76)	292 (11.50)	36 (1.42)	12.1 (26.7)
	3/4	B1C6	F07	194 (7.64)	115 (4.53)	83 (3.27)	395 (15.55)	125 (4.92)	451 (17.76)	292 (11.50)	36 (1.42)	13.3 (29.3)
	1	B1C6	F07	197 (7.76)	125 (4.92)	83 (3.27)	395 (15.55)	125 (4.92)	451 (17.76)	292 (11.50)	36 (1.42)	14.0 (30.8)
	1 1/2	B1C6	F07	235 (9.25)	155 (6.10)	83 (3.27)	395 (15.55)	125 (4.92)	478 (18.82)	319 (12.56)	36 (1.42)	21.5 (47.4)
	2	B1C6	F07	267 (10.51)	165 (6.50)	83 (3.27)	395 (15.55)	125 (4.92)	478 (18.82)	319 (12.56)	36 (1.42)	23.4 (51.6)
		B1C11	F10	318 (12.52)	210 (8.26)	124 (4.88)	535 (21.06)	160 (6.30)	644 (25.35)	485 (19.10)	51 (2.01)	50.6 (111.3)
	3	B1C13	F12	318 (12.52)	210 (8.26)	155 (6.10)	640 (25.20)	195 (7.68)	690 (27.17)	521 (20.51)	65 (2.56)	66.1 (145.4)
		B1C13	F12	368 (14.49)	255 (10.03)	155 (6.10)	640 (25.20)	195 (7.68)	727 (28.62)	558 (21.97)	65 (2.56)	102.2 (224.8)
4	B1C17	F14	368 (14.49)	255 (10.03)	186 (7.32)	785 (30.91)	230 (9.06)	756 (29.76)	590 (23.23)	78 (3.07)	129.7 (285.3)	

Class 600

Type	SIZE	ACTUATOR	ISO FLANGE	DIMENSIONS, mm (inch)							kg (lbs)	
				A	ØB	E	F	G	H	K		V
ZXF, ZXN, ZXP	1/2	B1C6	F07	203 (7.99)	95 (3.74)	83 (3.27)	395 (15.55)	125 (4.92)	451 (17.76)	292 (11.50)	36 (1.42)	12.2 (26.9)
	3/4	B1C6	F07	206 (8.11)	115 (4.53)	83 (3.27)	395 (15.55)	125 (4.92)	451 (17.76)	292 (11.50)	36 (1.42)	13.2 (29.1)
	1	B1C6	F07	210 (8.27)	125 (4.92)	83 (3.27)	395 (15.55)	125 (4.92)	451 (17.76)	292 (11.50)	36 (1.42)	14.1 (31.1)
	1 1/2	B1C6	F07	251 (9.88)	155 (6.10)	83 (3.27)	395 (15.55)	125 (4.92)	478 (18.82)	319 (12.56)	36 (1.42)	22.3 (49.1)
		B1C9	F07	251 (9.88)	155 (6.10)	102 (4.02)	450 (17.72)	135 (5.31)	480 (18.90)	321 (12.64)	43 (1.69)	27.7 (61.1)
	2	B1C6	F07	286 (11.26)	165 (6.50)	83 (3.27)	395 (15.55)	125 (4.92)	478 (18.82)	319 (12.56)	36 (1.42)	24.5 (54.0)
		B1C9	F07	286 (11.26)	165 (6.50)	102 (4.02)	450 (17.72)	135 (5.31)	480 (18.90)	321 (12.64)	43 (1.69)	29.9 (65.9)
	3	B1C11	F10	337 (13.26)	210 (8.26)	124 (4.88)	535 (21.06)	160 (6.30)	644 (25.35)	485 (19.10)	51 (2.01)	59.9 (131.8)
B1C13		F12	337 (13.26)	210 (8.26)	155 (6.10)	640 (25.20)	195 (7.68)	690 (27.17)	521 (20.51)	65 (2.56)	75.1 (165.2)	
4	B1C13	F12	394 (15.5)	275 (10.82)	155 (6.10)	640 (25.20)	195 (7.68)	727 (28.62)	558 (21.97)	65 (2.56)	108.7 (239.1)	
	B1C17	F14	394 (15.5)	275 (10.82)	186 (7.32)	785 (30.91)	230 (9.06)	756 (29.76)	590 (23.23)	78 (3.07)	136.2 (299.6)	

Class 900

Type	SIZE	ACTUATOR	ISO FLANGE	DIMENSIONS, mm (inch)							kg (lbs)	
				A	ØB	E	F	G	H	K		V
ZXG	3	B1C13	F12	441 (17.36)	240 (9.45)	155 (6.10)	640 (25.20)	195 (7.68)	746 (29.37)	580 (22.83)	65 (2.56)	131.9 (290.8)
		B1C17	F14	441 (17.36)	240 (9.45)	186 (7.32)	785 (30.91)	230 (9.06)	778 (30.63)	612 (24.09)	78 (3.07)	154.9 (341.5)
		B1C20	F14	441 (17.36)	240 (9.45)	205 (8.07)	880 (34.65)	290 (11.42)	811 (31.93)	645 (25.39)	97 (3.82)	173.9 (383.4)
	4	B1C17	F14	511 (20.12)	290 (11.42)	186 (7.32)	785 (30.91)	230 (9.06)	850 (33.46)	684 (26.93)	78 (3.07)	220.6 (486.3)
		B1C20	F14	511 (20.12)	290 (11.42)	205 (8.07)	880 (34.65)	290 (11.42)	883 (34.76)	717 (28.23)	97 (3.82)	239.6 (528.2)
		B1C25	F16	511 (20.12)	290 (11.42)	254 (10.00)	1075 (42.32)	350 (13.78)	943 (37.13)	777 (30.59)	121 (4.76)	297.6 (656.1)

Class 1500

Type	SIZE	ACTUATOR	ISO FLANGE	DIMENSIONS, mm (inch)							kg (lbs)	
				A	ØB	E	F	G	H	K		V
ZXH	1	B1C6	F07	292 (11.50)	150 (5.91)	83 (3.27)	395 (15.55)	125 (4.92)	506 (19.92)	347 (13.66)	36 (1.42)	30.0 (66.1)
		B1C9	F07	292 (11.50)	150 (5.91)	102 (4.02)	450 (17.72)	135 (5.31)	508 (20.00)	349 (13.74)	43 (1.69)	35.4 (78.0)
	1 1/2	B1C11	F10	333 (13.11)	180 (7.09)	124 (4.88)	535 (21.06)	160 (6.30)	620 (24.41)	461 (18.15)	51 (2.01)	56.3 (124.1)
		B1C13	F12	333 (13.11)	180 (7.09)	155 (6.10)	640 (25.20)	195 (7.68)	656 (25.83)	487 (19.17)	65 (2.56)	71.5 (157.6)
	2	B1C11	F10	375 (14.76)	215 (8.46)	124 (4.88)	535 (21.06)	160 (6.30)	620 (24.41)	461 (18.15)	51 (2.01)	65.5 (148.7)
		B1C13	F12	375 (14.76)	215 (8.46)	155 (6.10)	640 (25.20)	195 (7.68)	656 (25.83)	487 (19.17)	65 (2.56)	82.6 (182.1)
	3	B1C13	F12	460 (18.11)	265 (10.43)	155 (6.10)	640 (25.20)	195 (7.68)	746 (29.37)	580 (22.83)	65 (2.56)	142.9 (315.0)
		B1C17	F14	460 (18.11)	265 (10.43)	186 (7.32)	785 (30.91)	230 (9.06)	778 (30.63)	612 (24.09)	78 (3.07)	165.9 (365.7)
	4	B1C20	F14	460 (18.11)	265 (10.43)	205 (8.07)	880 (34.65)	290 (11.42)	811 (31.93)	645 (25.39)	97 (3.82)	184.9 (407.6)
		B1C17	F14	530 (20.87)	310 (12.20)	186 (7.32)	785 (30.91)	230 (9.06)	850 (33.46)	684 (26.93)	78 (3.07)	235.1 (518.3)
	4	B1C20	F14	530 (20.87)	310 (12.20)	205 (8.07)	880 (34.65)	290 (11.42)	883 (34.76)	717 (28.23)	97 (3.82)	254.1 (560.2)
		B1C25	F16	530 (20.87)	310 (12.20)	254 (10.00)	1075 (42.32)	350 (13.78)	943 (37.13)	777 (30.59)	121 (4.76)	312.1 (688.1)

Class 150

TYPE	SIZE	ACTUATOR	ISO FLANGE	Dimensions, mm (inch)								kg (lbs)
				A	ØB	E	F	G	H	K	V	
ZXC	1/2	B1J_6	F07	184 (7.24)	90 (3.54)	100 (3.94)	485 (19.01)	118 (4.65)	451 (17.76)	292 (11.50)	36 (1.42)	19.9 (43.9)
	3/4	B1J_6	F07	184 (7.24)	100 (3.94)	100 (3.94)	485 (19.01)	118 (4.65)	451 (17.76)	292 (11.50)	36 (1.42)	20.3 (44.8)
	1	B1J_6	F07	184 (7.24)	110 (4.33)	100 (3.94)	485 (19.01)	118 (4.65)	451 (17.76)	292 (11.50)	36 (1.42)	20.7 (45.6)
	1 1/2	B1J_6	F07	222 (8.74)	125 (4.92)	100 (3.94)	485 (19.01)	118 (4.65)	478 (18.82)	319 (12.56)	36 (1.42)	26.5 (58.4)
	2	B1J_6	F07	254 (10.00)	150 (5.91)	100 (3.94)	485 (19.01)	118 (4.65)	478 (18.82)	319 (12.56)	36 (1.42)	28.5 (62.8)
	1/2	B1J_8	F07	184 (7.24)	90 (3.54)	117 (4.61)	555 (21.85)	135 (5.31)	453 (17.83)	294 (11.57)	43 (1.69)	23.9 (52.7)
	3/4	B1J_8	F07	184 (7.24)	100 (3.94)	117 (4.61)	555 (21.85)	135 (5.31)	453 (17.83)	294 (11.57)	43 (1.69)	24.3 (53.6)
	1	B1J_8	F07	184 (7.24)	110 (4.33)	117 (4.61)	555 (21.85)	135 (5.31)	453 (17.83)	294 (11.57)	43 (1.69)	24.7 (54.4)
	1 1/2	B1J_8	F07	222 (8.74)	125 (4.92)	117 (4.61)	555 (21.85)	135 (5.31)	480 (18.90)	321 (12.64)	43 (1.69)	30.5 (67.2)
	2	B1J_8	F07	254 (10.00)	150 (5.91)	117 (4.61)	555 (21.85)	135 (5.31)	480 (18.90)	321 (12.64)	43 (1.69)	32.5 (71.6)
	3	B1J_10	F10	298 (11.73)	190 (7.48)	137 (5.39)	640 (25.20)	160 (6.30)	617 (24.29)	458 (18.03)	51 (2.01)	60 (132)
		B1J_12	F12	352 (13.85)	230 (9.05)	172 (6.77)	815 (32.09)	195 (7.68)	690 (27.17)	521 (20.51)	65 (2.56)	90.8 (199.8)
		B1J_12	F12	352 (13.85)	230 (9.05)	172 (6.77)	815 (32.09)	195 (7.68)	727 (28.62)	558 (21.97)	65 (2.56)	123.8 (272.4)
		B1J_16	F14	352 (13.85)	230 (9.05)	211 (8.31)	990 (38.98)	230 (9.06)	756 (29.76)	590 (23.23)	78 (3.07)	168 (369.6)
	4	B1J_20	F14	352 (13.85)	230 (9.05)	295 (11.61)	1230 (48.43)	290 (11.42)	796 (31.34)	630 (24.80)	97 (3.82)	243 (534.6)

Class 300

TYPE	SIZE	ACTUATOR	ISO FLANGE	Dimensions, mm (inch)								kg (lbs)
				A	ØB	E	F	G	H	K	V	
ZXD, ZXM	1/2	B1J_6	F07	190 (7.48)	95 (3.74)	100 (3.94)	485 (19.01)	118 (4.65)	451 (17.76)	292 (11.50)	36 (1.42)	20.9 (46.1)
	3/4	B1J_6	F07	194 (7.64)	115 (4.53)	100 (3.94)	485 (19.01)	118 (4.65)	451 (17.76)	292 (11.50)	36 (1.42)	22.1 (48.7)
	1	B1J_6	F07	197 (7.76)	125 (4.92)	100 (3.94)	485 (19.01)	118 (4.65)	451 (17.76)	292 (11.50)	36 (1.42)	22.8 (50.3)
	1 1/2	B1J_6	F07	235 (9.25)	155 (6.10)	100 (3.94)	485 (19.01)	118 (4.65)	478 (18.82)	319 (12.56)	36 (1.42)	30.3 (66.8)
	2	B1J_6	F07	267 (10.51)	165 (6.50)	100 (3.94)	485 (19.01)	118 (4.65)	478 (18.82)	319 (12.56)	36 (1.42)	32.2 (71.0)
	1/2	B1J_8	F07	190 (7.48)	95 (3.74)	117 (4.61)	555 (21.85)	135 (5.31)	453 (17.83)	294 (11.57)	43 (1.69)	24.9 (54.9)
	3/4	B1J_8	F07	194 (7.64)	115 (4.53)	117 (4.61)	555 (21.85)	135 (5.31)	453 (17.83)	294 (11.57)	43 (1.69)	26.1 (57.5)
	1	B1J_8	F07	197 (7.76)	125 (4.92)	117 (4.61)	555 (21.85)	135 (5.31)	453 (17.83)	294 (11.57)	43 (1.69)	26.8 (59.1)
	1 1/2	B1J_8	F07	235 (9.25)	155 (6.10)	117 (4.61)	555 (21.85)	135 (5.31)	480 (18.90)	321 (12.64)	43 (1.69)	34.3 (75.6)
	2	B1J_8	F07	267 (10.51)	165 (6.50)	117 (4.61)	555 (21.85)	135 (5.31)	480 (18.90)	321 (12.64)	43 (1.69)	36.2 (79.8)
	3	B1J_10	F10	316 (12.43)	210 (8.26)	137 (5.39)	640 (25.20)	160 (6.30)	617 (24.29)	458 (18.03)	51 (2.01)	64.9 (142.8)
		B1J_12	F12	316 (12.43)	210 (8.26)	172 (6.77)	815 (32.09)	195 (7.68)	690 (27.17)	521 (20.51)	65 (2.56)	95.7 (210.5)
	4	B1J_12	F12	368.2 (14.49)	255 (10.03)	172 (6.77)	815 (32.09)	195 (7.68)	727 (28.62)	558 (21.97)	65 (2.56)	131.8 (290)
		B1J_16	F14	368.2 (14.49)	255 (10.03)	211 (8.31)	990 (38.98)	230 (9.06)	756 (29.76)	590 (23.23)	78 (3.07)	176 (387.2)
		B1J_20	F14	368.2 (14.49)	255 (10.03)	295 (11.61)	1230 (48.43)	290 (11.42)	796 (31.34)	630 (24.80)	97 (3.82)	251 (552.2)

Class 600

TYPE	SIZE	ACTUATOR	ISO FLANGE	Dimensions, mm (inch)								kg (lbs)
				A	ØB	E	F	G	H	K	V	
ZXF, ZXN, ZXP	1/2	B1J_6	F07	203 (7.99)	95 (3.74)	100 (3.94)	485 (19.01)	118 (4.65)	451 (17.76)	292 (11.50)	36 (1.42)	21 (46.3)
	3/4	B1J_6	F07	206 (8.11)	115 (4.53)	100 (3.94)	485 (19.01)	118 (4.65)	451 (17.76)	292 (11.50)	36 (1.42)	22 (48.5)
	1	B1J_6	F07	210 (8.27)	125 (4.92)	100 (3.94)	485 (19.01)	118 (4.65)	451 (17.76)	292 (11.50)	36 (1.42)	22.9 (50.5)
	1 1/2	B1J_6	F07	251 (9.88)	155 (6.10)	100 (3.94)	485 (19.01)	118 (4.65)	478 (18.82)	319 (12.56)	36 (1.42)	31.1 (68.6)
	1/2	B1J_8	F07	203 (7.99)	95 (3.74)	117 (4.61)	555 (21.85)	135 (5.31)	453 (17.83)	294 (11.57)	43 (1.69)	25.0 (55.1)
	3/4	B1J_8	F07	206 (8.11)	115 (4.53)	117 (4.61)	555 (21.85)	135 (5.31)	453 (17.83)	294 (11.57)	43 (1.69)	26.0 (57.3)
	1	B1J_8	F07	210 (8.27)	125 (4.92)	117 (4.61)	555 (21.85)	135 (5.31)	453 (17.83)	294 (11.57)	43 (1.69)	26.9 (59.3)
	1 1/2	B1J_8	F07	251 (9.88)	155 (6.10)	117 (4.61)	555 (21.85)	135 (5.31)	480 (18.90)	321 (12.64)	43 (1.69)	35.1 (77.4)
		B1J_10	F10	251 (9.88)	155 (6.10)	137 (5.39)	640 (25.20)	160 (6.30)	494 (19.45)	335 (13.19)	51 (2.01)	48.1 (106.0)
	2	B1J_6	F07	286 (11.26)	165 (6.50)	100 (3.94)	485 (19.01)	118 (4.65)	478 (18.82)	319 (12.56)	36 (1.42)	33.3 (73.4)
		B1J_8	F07	286 (11.26)	165 (6.50)	117 (4.61)	555 (21.85)	135 (5.31)	480 (18.90)	321 (12.64)	43 (1.69)	37.3 (82.2)
	3	B1J_10	F10	286 (11.26)	165 (6.50)	137 (5.39)	640 (25.20)	160 (6.30)	494 (19.45)	335 (13.19)	51 (2.01)	50.3 (110.9)
		B1J_10	F10	337 (13.26)	210 (8.26)	137 (5.39)	640 (25.20)	160 (6.30)	617 (24.29)	458 (18.03)	51 (2.01)	73.9 (162.6)
	4	B1J_12	F12	337 (13.26)	210 (8.26)	172 (6.77)	815 (32.09)	195 (7.68)	690 (27.17)	521 (20.51)	65 (2.56)	104.7 (230.3)
		B1J_12	F12	394 (15.5)	275 (10.82)	172 (6.77)	815 (32.09)	195 (7.68)	727 (28.62)	558 (21.97)	65 (2.56)	138.3 (140.5)
		B1J_16	F14	394 (15.5)	275 (10.82)	211 (8.31)	990 (38.98)	230 (9.06)	756 (29.76)	590 (23.23)	78 (3.07)	182.5 (401.5)
B1J_20		F14	394 (15.5)	275 (10.82)	295 (11.61)	1230 (48.43)	290 (11.42)	796 (31.34)	630 (24.80)	97 (3.82)	257.5 (566.5)	

Class 900

TYPE	SIZE	ACTUATOR	ISO FLANGE	Dimensions, mm (inch)								kg (lbs)
				A	ØB	E	F	G	H	K	V	
ZXG	3	B1J_12	F12	441 (17.36)	240 (9.45)	173 (6.81)	815 (32.09)	195 (7.68)	746 (29.37)	580 (22.83)	65 (2.56)	157 (348.1)
		B1J_16	F14	441 (17.36)	240 (9.45)	211 (8.31)	990 (38.98)	230 (9.06)	778 (30.63)	612 (24.09)	78 (3.07)	200.9 (442.9)
		B1J_20	F14	441 (17.36)	240 (9.45)	295 (11.61)	1230 (48.43)	290 (11.42)	811 (31.93)	645 (25.39)	97 (3.82)	275.9 (608.3)
	4	B1J_16	F14	511 (20.12)	290 (11.42)	211 (8.31)	990 (38.98)	230 (9.06)	850 (33.46)	684 (26.93)	78 (3.07)	266.9 (588.4)
		B1J_20	F14	511 (20.12)	290 (11.42)	295 (11.61)	1230 (48.43)	290 (11.42)	883 (34.76)	717 (28.23)	97 (3.82)	341.9 (753.8)
		B1J_25	F16	511 (20.12)	290 (11.42)	374 (14.72)	1490 (58.66)	350 (13.78)	943 (37.13)	777 (30.59)	121 (4.76)	516.9 (1139.6)

Class 1500

TYPE	SIZE	ACTUATOR	ISO FLANGE	Dimensions, mm (inch)								kg (lbs)
				A	ØB	E	F	G	H	K	V	
ZXH	1	B1J_6	F07	292 (11.50)	150 (5.91)	100 (3.94)	485 (19.01)	118 (4.65)	451 (17.76)	292 (11.50)	36 (1.42)	38.8 (85.5)
		B1J_8	F07	292 (11.50)	150 (5.91)	117 (4.61)	555 (21.85)	135 (5.31)	453 (17.83)	294 (11.57)	43 (1.69)	42.8 (94.3)
		B1J_10	F10	333 (13.11)	180 (7.09)	137 (5.39)	640 (25.20)	160 (6.30)	522 (20.55)	363 (14.29)	51 (2.01)	42.8 (94.3)
	1 1/2	B1J_10	F10	333 (13.11)	180 (7.09)	137 (5.39)	640 (25.20)	160 (6.30)	620 (24.41)	461 (18.15)	51 (2.01)	70.3 (155.0)
		B1J_12	F12	333 (13.11)	180 (7.09)	172 (6.77)	815 (32.09)	195 (7.68)	656 (25.83)	487 (19.17)	65 (2.56)	97.5 (214.9)
		B1J_10	F10	375 (14.76)	215 (8.46)	137 (5.39)	640 (25.20)	160 (6.30)	620 (24.41)	461 (18.15)	51 (2.01)	81.5 (179.6)
	2	B1J_12	F12	375 (14.76)	215 (8.46)	172 (6.77)	815 (32.09)	195 (7.68)	656 (25.83)	487 (19.17)	65 (2.56)	108.6 (239.4)
		B1J_12	F12	460 (18.11)	265 (10.43)	173 (6.81)	815 (32.09)	195 (7.68)	746 (29.37)	580 (22.83)	65 (2.56)	168.9 (372.4)
		B1J_16	F14	460 (18.11)	265 (10.43)	211 (8.31)	990 (38.98)	230 (9.06)	778 (30.63)	612 (24.09)	78 (3.07)	211.9 (467.2)
	3	B1J_20	F14	460 (18.11)	265 (10.43)	295 (11.61)	1230 (48.43)	290 (11.42)	811 (31.93)	645 (25.39)	97 (3.82)	286.9 (632.5)
		B1J_16	F14	530 (20.87)	310 (12.20)	211 (8.31)	990 (38.98)	230 (9.06)	850 (33.46)	684 (26.93)	78 (3.07)	281.1 (619.7)
		B1J_20	F14	530 (20.87)	310 (12.20)	295 (11.61)	1230 (48.43)	290 (11.42)	883 (34.76)	717 (28.23)	97 (3.82)	356.1 (785.1)
4	B1J_25	F16	530 (20.87)	310 (12.20)	374 (14.72)	1490 (58.66)	350 (13.78)	943 (37.13)	777 (30.59)	121 (4.76)	531.1 (1170.9)	

HOW TO ORDER

RotaryGlobe Control Valve, Series ZX

Example: The following example is for a RotaryGlobe valve (ZX), with an ASME Class 300 body (D), 1" size with CF8M / 1.4408 body material (A), stem, pin and seat material 17-4PH + HCr AISI 316 Nitronic 60 (A), PTFE V-ring packing (A) and linear trim type (L060).

1.	2.	3.	4.	5.	6.	7.
ZX	D	01	A	A	A	L060

1.	VALVE SERIES, CONNECTION AND FACE TO FACE LENGTH
ZX	RotaryGlobe valve, flanged, f-to-f length acc. to ISA S75.03 and EN 558-2 series 37-39

2.	PRESSURE RATING, FLANGES, FLANGE DRILLINGS
C	ASME class 150
D	ASME class 300
F	ASME class 600
G	ASME class 900 (available for sizes 3" and 4")*
H	ASME class 1500 (not available for sizes 1/2" and 3/4")
M	PN40 (PN10-40)
N	PN63
P	PN100

*) In sizes 1", 1 1/2" and 2" class 900 sign (H) as class 1500

3.	SIZE
0H	1/2"
3Q	3/4"
01	1"
1H	1 1/2"
02	2"
03"	3"
04"	4"

4.	BODY MATERIAL & BODY RELATED MATERIALS
Standard materials	
Body and bonnet	
A	CF8M / 1.4408
D	WCC / 1.0619
Optional materials	
Body and bonnet	
J	WC6 / F11 Cl 2

5.	PLUG, STEM, PIN AND SEAT CAGE MATERIALS			
Standard materials				
	Plug	Stem and pin	Seat Cage	Max. temp.
A	17-4PH + HCr	AISI 316	Nitronic 60	425 °C
Optional materials				
	Plug	Stem and pin	Seat Cage	Max. temp.
J	17-4PH + HCr	AISI 316	Nitronic 50	425 °C

6.	PACKING	SEALS
STANDARD		
A	PTFE	Graphite
T	Live loaded PTFE	Graphite
F	Graphite	Graphite
G	Live loaded graphite	Graphite
OPTIONAL		
P	PTFE	PTFE
S	Live loaded PTFE	PTFE

7.	TRIM		
C _v VALUES FOR SIZES DN15 - DN25 / 1/2" - 1"			
TRIM TYPE	DESCRIPTION (SIZE)	C _v VALUE	INITIAL OPENINGS (h ₀) in %
L001	Linear (DN15-DN25 / 1/2" - 1")	0.1	16.7
L003	Linear (DN15-DN25 / 1/2" - 1")	0.3	16.7
L011	Linear (DN15-DN25 / 1/2" - 1")	1.1	16.7
L025	Linear (DN15-DN25 / 1/2" - 1")	2.5	16.7
L060	Linear (DN20-DN25 / 3/4" - 1")	6.0	15.0
L120	Linear (DN25 / 1")	12.0	12.8
E011	Equal % (DN15-DN25 / 1/2" - 1")	1.1	8.9
E022	Equal % (DN15-DN25 / 1/2" - 1")	2.2	15.6
E043	Equal % (DN15-DN25 / 1/2" - 1")	4.3	15.0
E090	Equal % (DN25 / 1")	9.0	12.8
B020	Balanced trim for high Δp and noise reduction. Linear (DN15-DN25 / 1/2" - 1")	2.0	15.0
B050	Balanced trim for high Δp and noise reduction. Linear (DN20-DN25 / 3/4" - 1")	5.0	15.0
C _v VALUES FOR SIZES DN40 - DN50 / 1 1/2" - 2"			
TRIM TYPE	DESCRIPTION	C _v VALUE	INITIAL OPENINGS (h ₀) in %
L030	Linear	3.0	15.0
L070	Linear	7.0	15.0
L150	Linear	15.0	13.3
L310	Linear	31.0	12.8
E115	Equal %	11.5	13.3
E260	Equal %	26.0	12.8
B050	Balanced trim for high Δp and noise reduction. Linear.	6.0	15.0
B130	Balanced trim for high Δp and noise reduction. Linear.	13.0	15.0
C _v VALUES FOR SIZE DN80 / 3"			
TRIM TYPE	DESCRIPTION	C _v VALUE	INITIAL OPENINGS (h ₀) in %
L180	Linear	18	8.9
L350	Linear	35	9.4
L550	Linear	55	8.3
E320	Equal %	32	10.0
E460	Equal %	46	8.9
B130	Balanced trim for high Δp and noise reduction. Linear.	13	9.4
B280	Balanced trim for high Δp and noise reduction. Linear.	28	9.4
C _v VALUES FOR SIZE DN100 / 4"			
TRIM TYPE	DESCRIPTION	C _v VALUE	INITIAL OPENINGS (h ₀) in %
L350	Linear	35	9.4
L700	Linear	70	9.4
L1150	Linear	115	9.4
E540	Equal %	54	9.4
E800	Equal %	80	9.4
B280	Balanced trim for high Δp and noise reduction. Linear.	28	10.0
B520	Balanced trim for high Δp and noise reduction. Linear.	52	10.0

Metso Corporation

Töölönlahdenkatu 2, PO Box 1220, 00100 Helsinki, Finland
Tel. +358 20 484 100

Metso Flow Control Inc.

Vanha Porvoontie 229, P.O. Box 304, FI-01301 VANTAA, Finland.
Tel. +358 20 483 150. Fax +358 20 483 151

www.metso.com/valves

Subject to change without prior notice. Product names in this bulletin are all trademarks of Metso Flow Control Inc.

