

# Intrinsically safe submersible pressure transmitter

## For applications in hazardous areas

### Model IL-10

WIKA data sheet PE 81.23



for further approvals  
see page 4

#### Applications

- Wastewater treatment and biogas production
- Brackish water and fuel tanks in shipbuilding
- Oil and fuel storage tanks
- Mining and gas extraction
- Refineries
- Distilling equipment

#### Special features

- Suitable for all level measurements in hazardous areas
- Explosion protection in accordance with ATEX, FM and CSA
- Shipbuilding approval in accordance with GL
- Ingress protection IP 68 up to 984 ft (300 m) immersion depth



**Intrinsically safe submersible pressure transmitter  
model IL-10**

#### Description

##### For the highest demands

The model IL-10 intrinsically safe submersible pressure transmitter has been designed for the highest requirements of level measurement. Owing to their high accuracy, reliability and their excellent media resistance, it is the ideal solution for almost all level measurements in hazardous areas.

Especially noteworthy are the outstanding approval-related characteristics (CENELEC approval per ATEX). In addition, the model IL-10 has the North-American approvals FM (USA) and CSA (Canada).

##### Design

A hermetically sealed and robust stainless steel case with an ingress protection IP 68 enables immersion depths of up to 984 ft (300 m).

The submersible pressure transmitter is supplied with a power supply of DC 10 ... 40 V via a suitable isolated barrier and provides an output signal of 4 ... 20 mA, 2-wire.

## Measuring ranges

Gauge pressure						
bar	<b>Measuring range</b>	<b>0 ... 0.1</b>	<b>0 ... 0.16</b>	<b>0 ... 0.25</b>	<b>0 ... 0.4</b>	<b>0 ... 0.6</b>
	Overpressure limit	1	1.5	2	2	3
	<b>Measuring range</b>	<b>0 ... 1</b>	<b>0 ... 1.6</b>	<b>0 ... 2.5</b>	<b>0 ... 4</b>	<b>0 ... 6</b>
	Overpressure limit	5	8	8	10	10
	<b>Measuring range</b>	<b>0 ... 10</b>	<b>0 ... 16</b>	<b>0 ... 25</b>		
	Overpressure limit	10	16	25		
inWC	<b>Measuring range</b>	<b>0 ... 50</b>	<b>0 ... 100</b>	<b>0 ... 150</b>	<b>0 ... 250</b>	
	Overpressure limit	750	750	750	1,100	
psi	<b>Measuring range</b>	<b>0 ... 5</b>	<b>0 ... 10</b>	<b>0 ... 15</b>	<b>0 ... 25</b>	<b>0 ... 50</b>
	Overpressure limit	30	45	70	120	150
	<b>Measuring range</b>	<b>0 ... 100</b>	<b>0 ... 160</b>	<b>0 ... 200</b>	<b>0 ... 300</b>	
	Overpressure limit	150	160	200	300	
	<b>Measuring range</b>	<b>0 ... 1</b>	<b>0 ... 1.6</b>	<b>0 ... 2.5</b>	<b>0 ... 4</b>	<b>0 ... 6</b>
	Overpressure limit	10	15	20	20	30
mH <sub>2</sub> O	<b>Measuring range</b>	<b>0 ... 10</b>	<b>0 ... 16</b>	<b>0 ... 25</b>	<b>0 ... 40</b>	<b>0 ... 60</b>
	Overpressure limit	50	80	80	100	100
	<b>Measuring range</b>	<b>0 ... 100</b>	<b>0 ... 160</b>	<b>0 ... 250</b>		
	Overpressure limit	100	160	250		

When choosing the FEP cable, measuring ranges up to and including 0 ... 10 bar, 0 ... 150 psi and 0 ... 100 mH<sub>2</sub>O are available. The given measuring ranges are also available in mbar, kPa and MPa.

## Output signal

### Signal

4 ... 20 mA, 2-wire

### Load in Ω

≤ (power supply - 10 V) / 0.02 A - (cable length in m x 0.14 Ω)

## Voltage supply

### Power supply

DC 10 ... 30 V

## Reference conditions

Temperature: 15 ... 25 °C (59 ... 77 °F)  
 Atmospheric pressure: 860 ... 1,060 mbar (12.5 ... 15.4 psi)  
 Humidity: 45 ... 75 % r. h.  
 Mounting position: Calibrated in vertical mounting position with process connection facing downwards.  
 Power supply: DC 24 V

## Accuracy data

### Accuracy at reference conditions

Measuring ranges < 0.25 bar (3.6 psi): ≤ ±0.50 % of span  
 Measuring ranges ≥ 0.25 bar (3.6 psi): ≤ ±0.25 % of span

Including non-linearity, hysteresis, zero offset and end value deviation (corresponds to measured error per IEC 61298-2).

### Non-linearity (per IEC 61298-2)

≤ ±0.2 % of span

### Non-repeatability

≤ ±0.1 % of span

### Temperature error at 32 ... 122 °F (0 ... 50 °C)

■ Mean temperature coefficient of zero point  
 Measuring ranges ≤ 0.25 bar (3.6 psi): ≤ ±0.4 % of span/10 K  
 Measuring ranges > 0.25 bar (3.6 psi): ≤ ±0.2 % of span/10 K

■ Mean temperature coefficient of span  
 ≤ ±0.2 % of span/10 K

### Long-term stability at reference conditions

≤ ±0.2 % of span/year

## Operating conditions

### Ingress protection (per IEC 60529)

IP 68

### Immersion depths

Submersible pressure transmitter with FEP cable: up to 100 m (328 ft)

Submersible pressure transmitter with PUR cable: up to 300 m (984 ft)

### Weight

Submersible pressure transmitter: approx. 200 g (0.44 lbs)

Cable: approx. 80 g/m (0.054 lbs/ft)

### Maximum tensile force of the cable

FEP cable: up to 350 N without strain relief

up to 500 N with strain relief

PUR cable: up to 350 N without strain relief

up to 1,000 N with strain relief

### Permissible temperature ranges

Medium: see table

Storage: -10 ... +60 °C (14 ... 140 °F)

Cable material	Category	Additional marking	Ambient and medium temperature (°C)
PUR	1G	EEx ia IIA	-10 ≤ Ta ≤ +60 (T6)
	2G		-10 ≤ Ta ≤ +60 (T5)
	1D	IP 65 T80 °C	-10 ≤ Ta ≤ +60 (T4)
	2D		-10 ≤ Ta ≤ +60
	M1	EEx ia I	-10 ≤ Ta ≤ +60
FEP	1G	EEx ia IIA	-10 ≤ Ta ≤ +60 (T6)
	2G		-10 ≤ Ta ≤ +80 (T5)
			-10 ≤ Ta ≤ +85 (T4)
	1D	IP 65 T80 °C	-10 ≤ Ta ≤ +85
	2D		
	M1	EEx ia I	-10 ≤ Ta ≤ +85

## Explosion protection

### Ignition protection types ATEX

II 1G EEx ia IIA T4/T5/T6

II 2G EEx ia IIA T4/T5/T6

II 1D IP 65 T80 °C

II 2D IP 65 T80 °C

I M1 EEx ia I

### Ignition protection types FM

Intrinsically safe class I, II and III, division 1, groups A, B, C, D, E, F and G

Class I, zone 0, AEx ia IIC dust ignitionproof for class II, III division 1, groups E, F and G

### Ignition protection types CSA

Class I, groups A, B, C and D; class II, groups E, F and G; class III

Class I, zone 0; Ex ia; IIC; IP65; DIP A20

### Safety-related maximum values for ATEX

Voltage U<sub>i</sub>: DC 30 V

Current I<sub>i</sub>: 100 mA

Power P<sub>i</sub>: 1 W

Signal current I<sub>s</sub>: 4 ... 20 mA

Effective internal capacitance C<sub>i</sub>

(dependent on cable length): 22 nF + 0.2 nF/m

Effective internal inductance L<sub>i</sub>

(dependent on cable length): 100 μH + 2 μH/m

For further operating conditions and safety-related data, please refer to the EC-type examination certificate at [www.wika.com](http://www.wika.com)

## Electrical connection

### Reverse polarity protection

U+ vs. U-

### Insulation voltage

DC 500 V

### Cable lengths

Available cable lengths					
Meter (m)	1.5	3	5	10	15
	20	25	30	40	50
	60	80	100	200	300
Feet (ft)	5	10	20	30	40
	50				

### Connection diagrams

Cable outlet		
	U+	brown
	U-	green
	Shield	grey

Transparent ventilation tube serves for pressure compensation between the interior of the instrument and the environment. Do not plug.

## Process connections

Standard	Thread size
-	G 1/2 B
-	G 1/4 female thread (only in Hastelloy®)

## Materials

### Wetted parts

	Standard	Option
Case, sensor, process connection	Stainless steel 316L	Hastelloy®
Protection cap	Stainless steel 316L	-
Cable	PUR	FEP

## CE conformity

### EMC directive

2004/108/EC, EN 61326 emission (group 1, class B) and interference immunity (industrial application)

### ATEX directive

94/9/EC

## Approvals



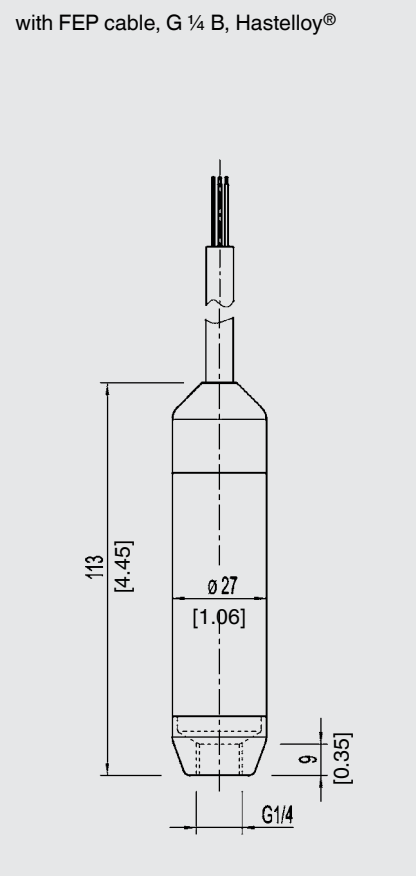
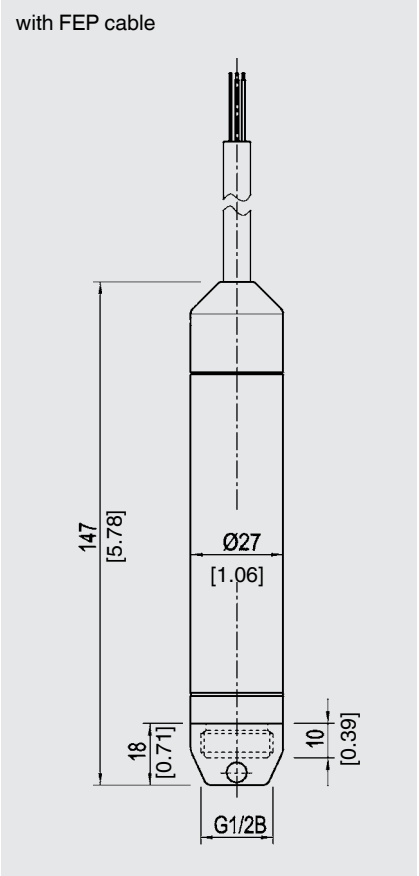
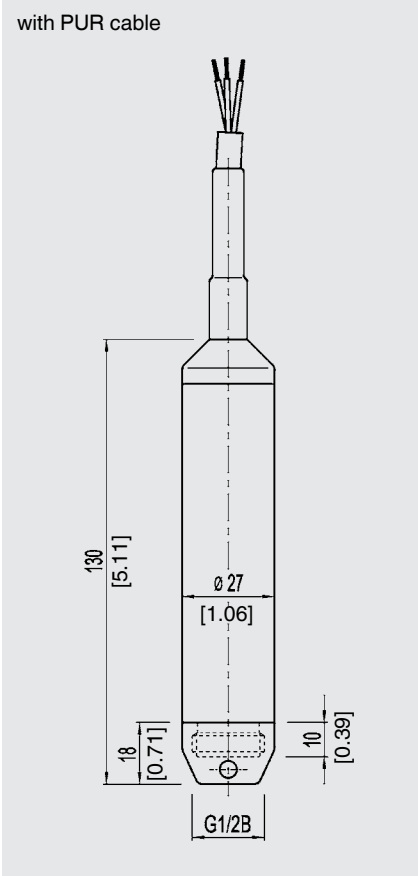

- **FM**, ignition protection type "I" - intrinsic safety, USA
- **cCSAus**, ignition protection type "I" - intrinsic safety, North America
- **GL**, ships, shipbuilding, (e.g. offshore) environmental category C, F, EMC 1, Germany
- **GOST-R**, import certificate, Russia
- **CRN**, safety (e.g. electr. safety, overpressure, ...), Canada

Approvals and certificates, see website

**Dimensions in mm [inch]**



## Accessories

	Description	Order no.																
	<p><b>Additional weight</b></p> <p>The additional weight increases the dead weight of the submersible pressure transmitter. It simplifies the lowering in monitoring wells, narrow shafts and deep wells. It effectively reduces negative environmental influences of the measuring medium (e.g. turbulent flows) on the measurement result.</p>	14052341 (stainless steel 316L)																
	<p><b>Cable strain relief clamp</b></p> <p>The cable strain relief clamp ensures easy and secure mechanical fastening of the submersible pressure transmitter's cable. It serves to guide the cable to prevent mechanical damage and to reduce the action of tensile stresses.</p>	14052336																
	<p><b>Filter element</b></p> <p>The filter element prevents dirt and moisture from entering the venting tube. The watertight diaphragm also offers a reliable protection for the submersible pressure transmitter in the harshest environments.</p>	14052344																
	<p><b>Isolated barrier, model KFD2-STC-Ex1</b></p> <table border="0"> <tr> <td>Dimensions</td> <td>20 x 122 x 115 mm</td> </tr> <tr> <td>Input/Output signal</td> <td>4 ... 20 mA, 0 ... 20 mA</td> </tr> <tr> <td>Input voltage</td> <td>DC 20 ... 35 V</td> </tr> <tr> <td>Transmitter power supply</td> <td>max DC 25.4 V</td> </tr> <tr> <td>Ambient temperature</td> <td>-20 ... +60 °C</td> </tr> <tr> <td>Ingress protection</td> <td>IP 20</td> </tr> <tr> <td>Mounting</td> <td>Standard rail, wall in non-hazardous area</td> </tr> <tr> <td>Explosion protection</td> <td>II (1) G [EEx ia] IIC</td> </tr> </table>	Dimensions	20 x 122 x 115 mm	Input/Output signal	4 ... 20 mA, 0 ... 20 mA	Input voltage	DC 20 ... 35 V	Transmitter power supply	max DC 25.4 V	Ambient temperature	-20 ... +60 °C	Ingress protection	IP 20	Mounting	Standard rail, wall in non-hazardous area	Explosion protection	II (1) G [EEx ia] IIC	2341268
Dimensions	20 x 122 x 115 mm																	
Input/Output signal	4 ... 20 mA, 0 ... 20 mA																	
Input voltage	DC 20 ... 35 V																	
Transmitter power supply	max DC 25.4 V																	
Ambient temperature	-20 ... +60 °C																	
Ingress protection	IP 20																	
Mounting	Standard rail, wall in non-hazardous area																	
Explosion protection	II (1) G [EEx ia] IIC																	

### Ordering information

Model / Measuring range / Process connection / Cable length / Materials / Accessories

## Accessories

Dimensions in inches (mm)

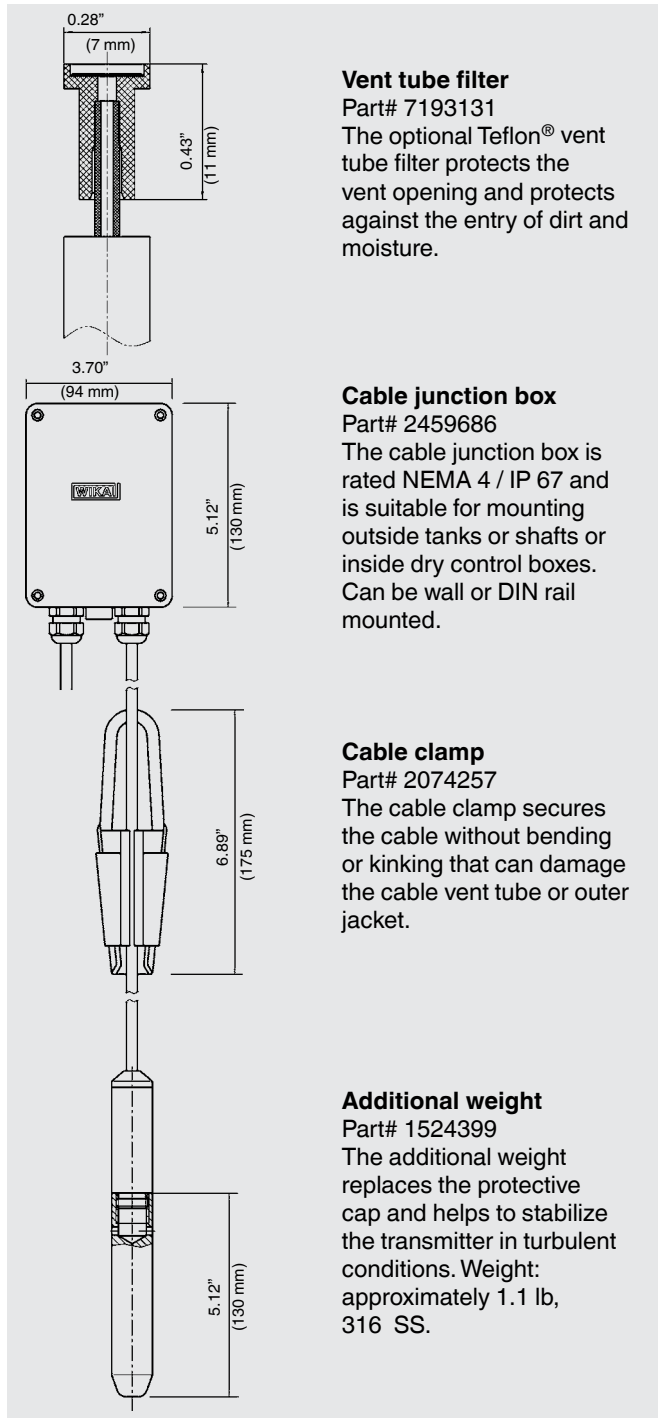

### Desiccant drying cartridge

part # 9836700

The desiccant drying cartridge helps prevent moisture buildup inside the vent tube.

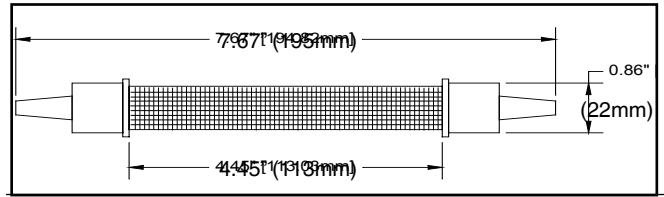

### NPT adapter

Part# 1631322

The 316 SS G1/2 adapter replaces the removable protective cap and converts the threads to 1/2" NPT male external, 1/4" female internal threads. Includes O-ring.

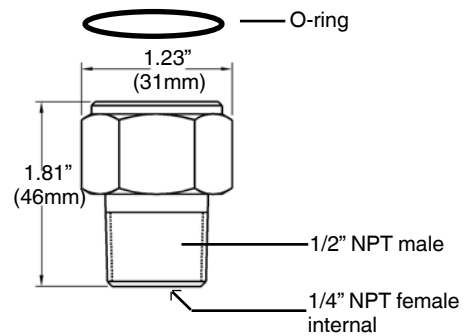

### Conduit adapter

Part# 50476114

316 SS 1/2" NPT male cable conduit adapter. Must be factory installed.

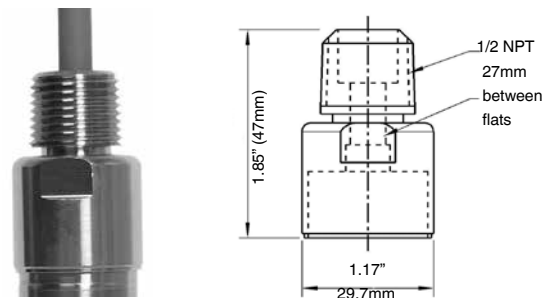

### LevelGuard Anti-clog attachment

Part # 50077091



The stainless steel LevelGuard attachment must be factory installed and calibrated.

