

Series AP



AVENTICS™ Series AP



2/2-directional valve, Series AP

- Qn = 350 l/min
- Compressed air connection output G 1/8
- Pipe connection



Version	Poppet valve
Activation	Mechanical
Switching principle	2/2
Nominal flow Qn	350 l/min
Working pressure min./max.	0 ... 10 bar
Ambient temperature min./max.	-30 ... 80 °C
Medium temperature min./max.	-30 ... 80 °C
Medium	Compressed air
Max. particle size	5 µm
Oil content of compressed air	0 ... 5 mg/m ³
Weight	See table below

An example configuration is illustrated.
The delivered product may thus deviate from the illustration.

Technical data

Part No.		Actuating element	Compressed air connection type	Compressed air connection Input
0820404020		Plunger	Internal thread	G 1/8
0820404021		Roller	Internal thread	G 1/8
0820404022		Roller lever, one-way trip	Internal thread	G 1/8
0820404023		Push button	Internal thread	G 1/8
0820404024		Lever	Internal thread	G 1/8

Part No.	Compressed air connection Output	Material actuating control	Weight	Fig.
0820404020	G 1/8	Brass	0.065 kg	Fig. 1
0820404021	G 1/8	Polyoxymethylene	0.075 kg	Fig. 2
0820404022	G 1/8	Polyoxymethylene Polyamide	0.075 kg	Fig. 3
0820404023	G 1/8	Polyamide	0.075 kg	Fig. 4
0820404024	G 1/8	Polyamide	0.065 kg	Fig. 5

Nominal flow Qn at 6 bar and Δp = 1 bar

Technical information

Material	
Housing	Aluminum
Seals	Acrylonitrile butadiene rubber
Actuating element	Brass Polyoxymethylene Polyoxymethylene, Polyamide Polyamide

Dimensions

Dimensions, Fig. 1

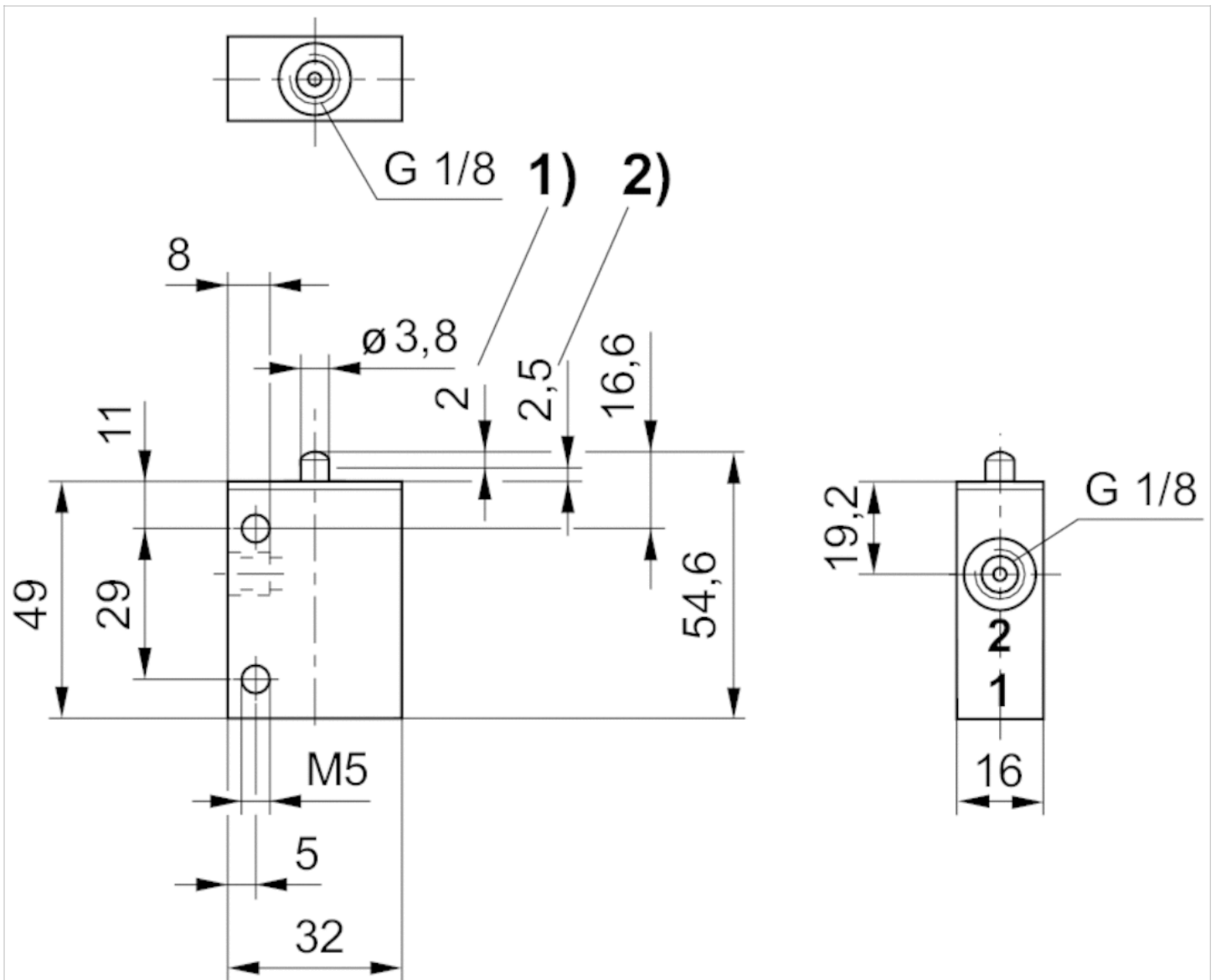

1) actuating stroke

2) overstroke

Dimensions of basic valve apply to all types of actuation.

Dimensions, Fig. 2

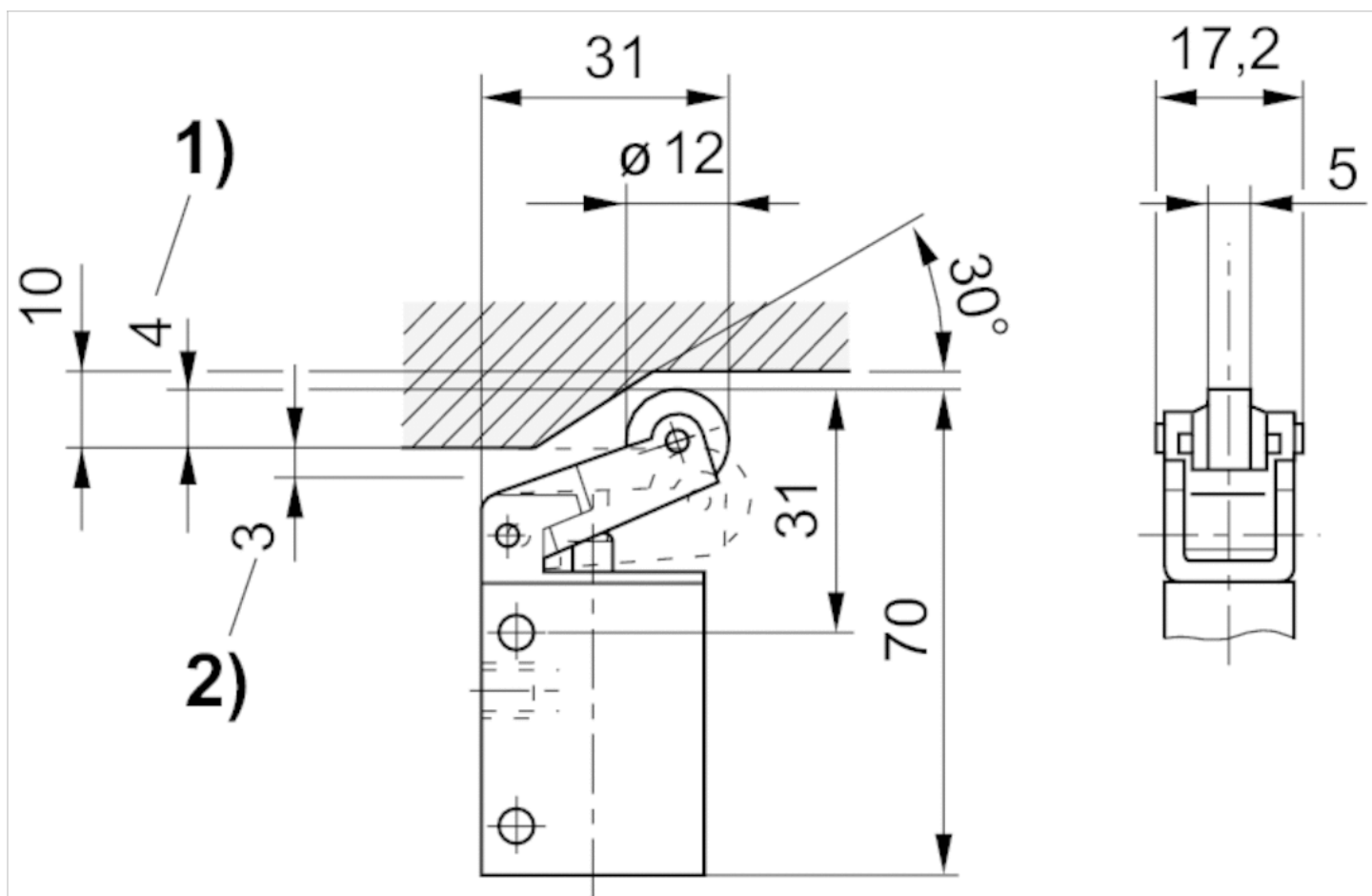

- 1) actuating stroke
- 2) overstroke

Dimensions, Fig. 3

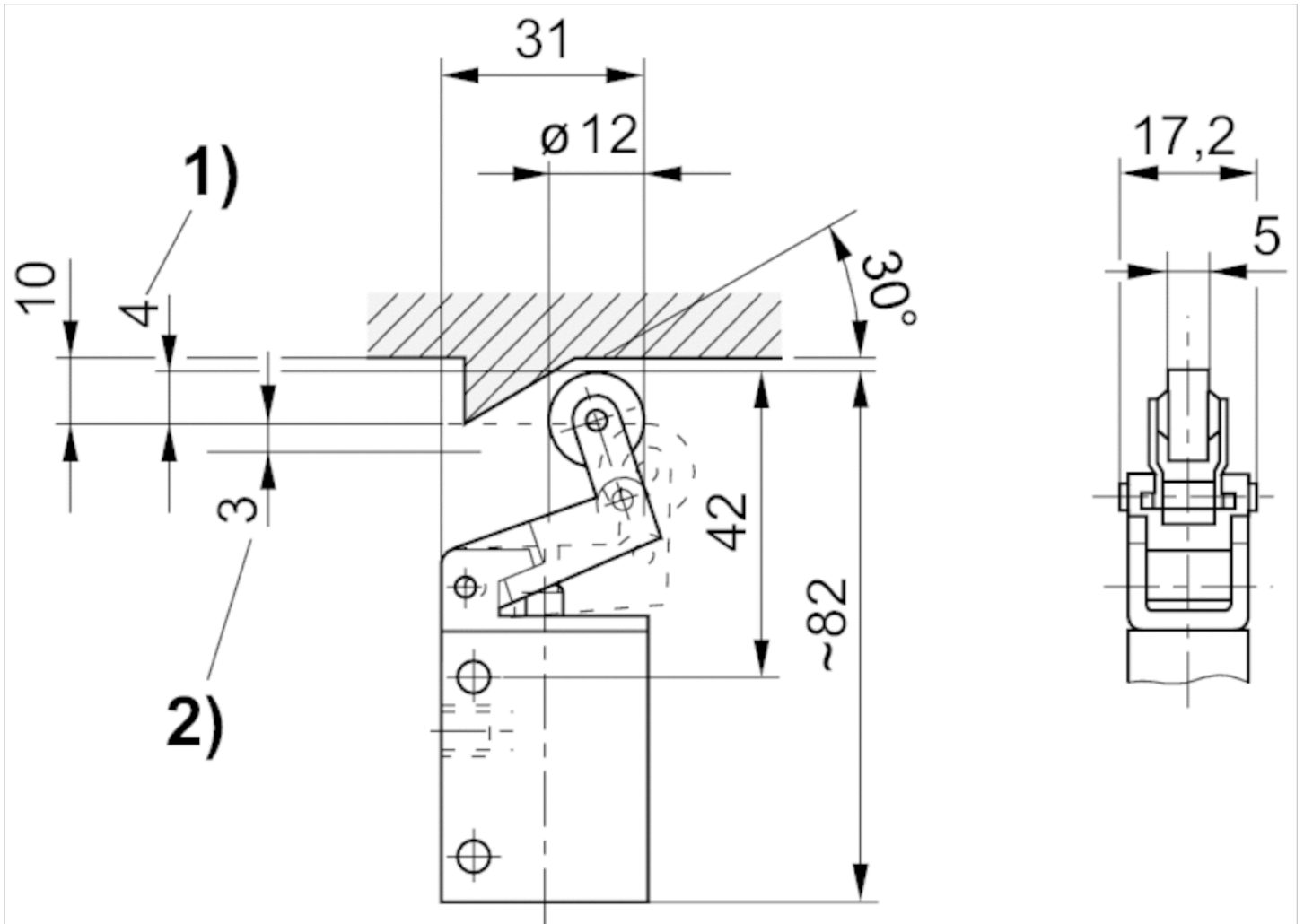

- 1) actuating stroke
- 2) overstroke

Dimensions, Fig. 4

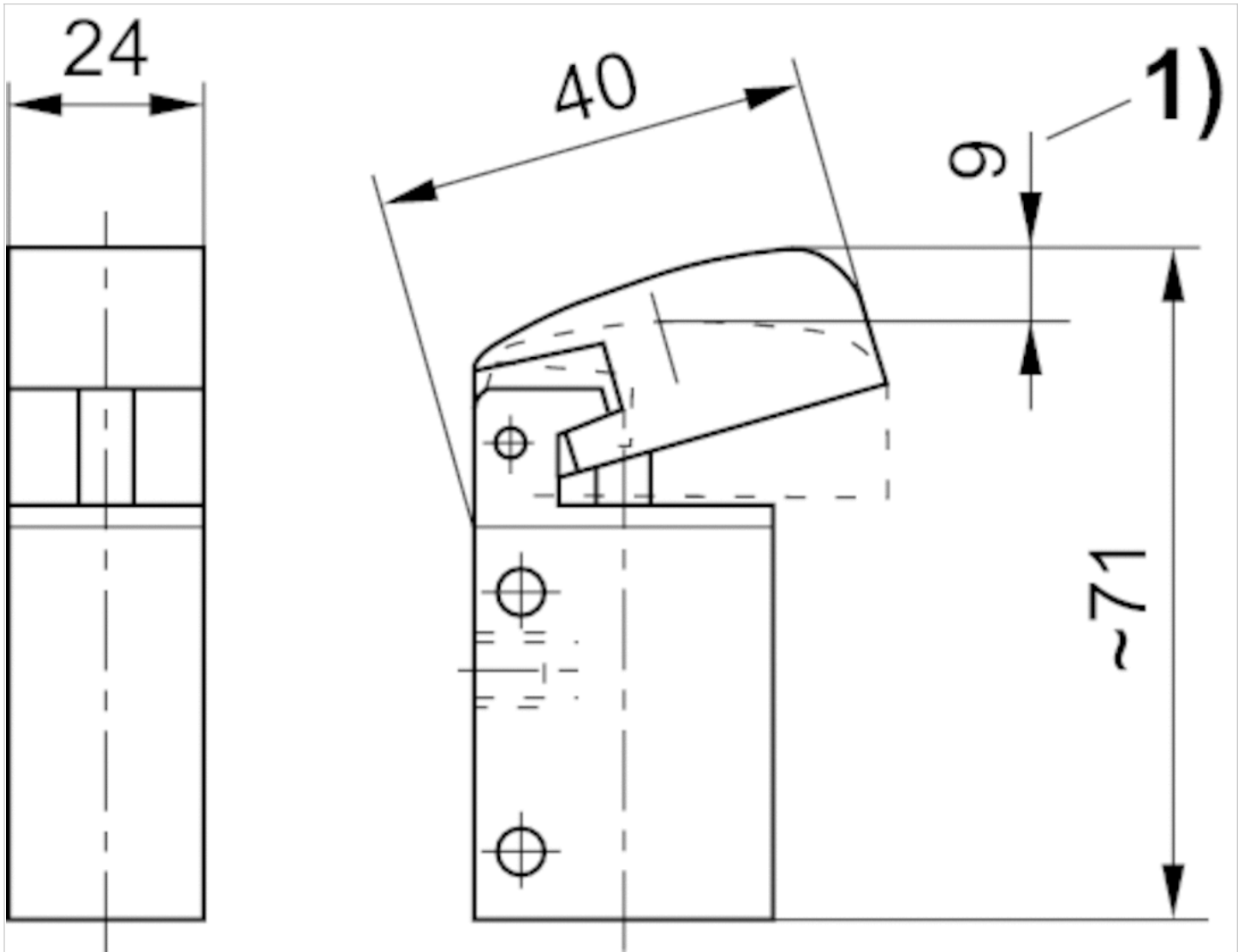

1) actuating stroke

Dimensions, Fig. 5

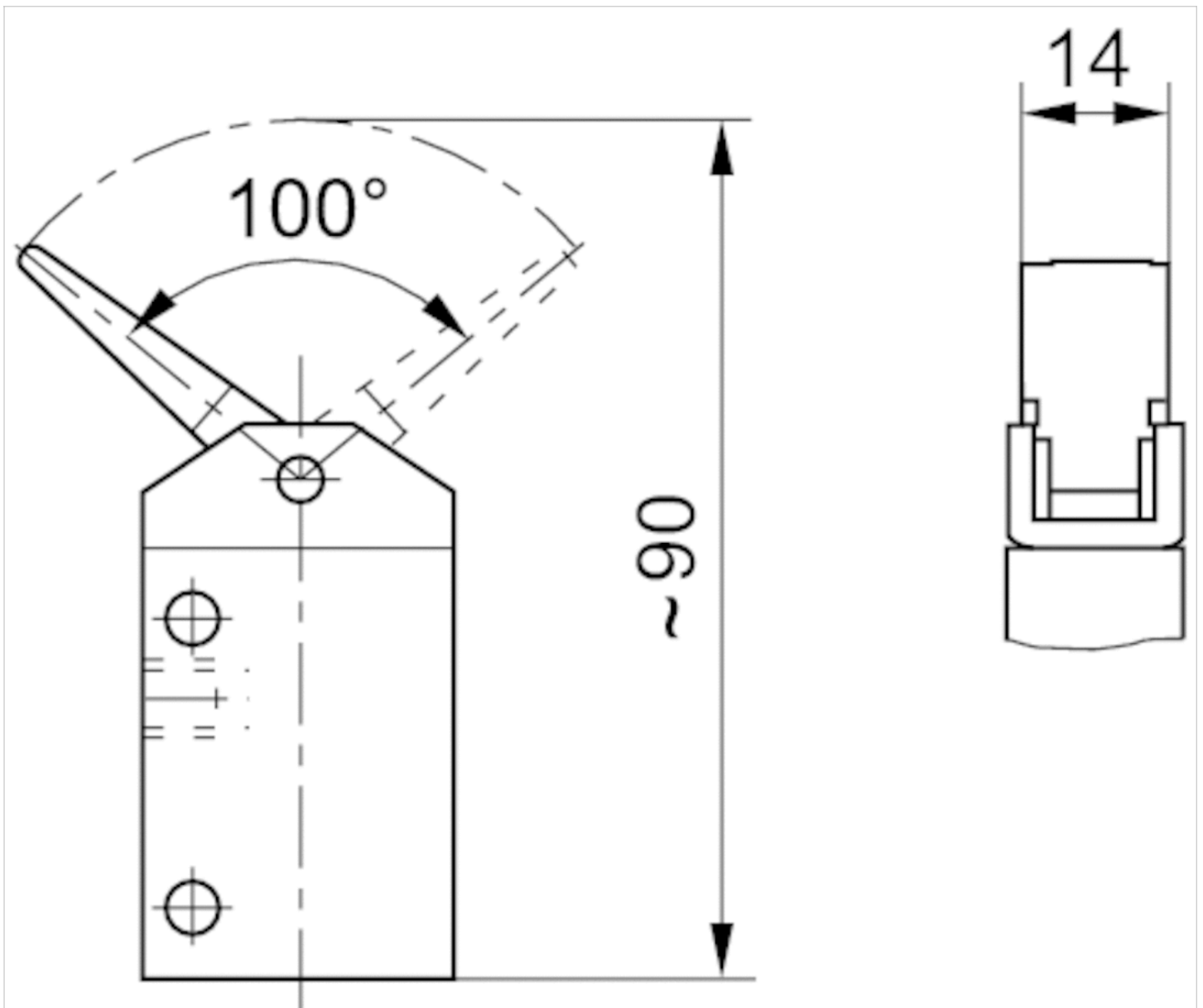

actuating torque: 6 Ncm

Diagrams

Actuating force+

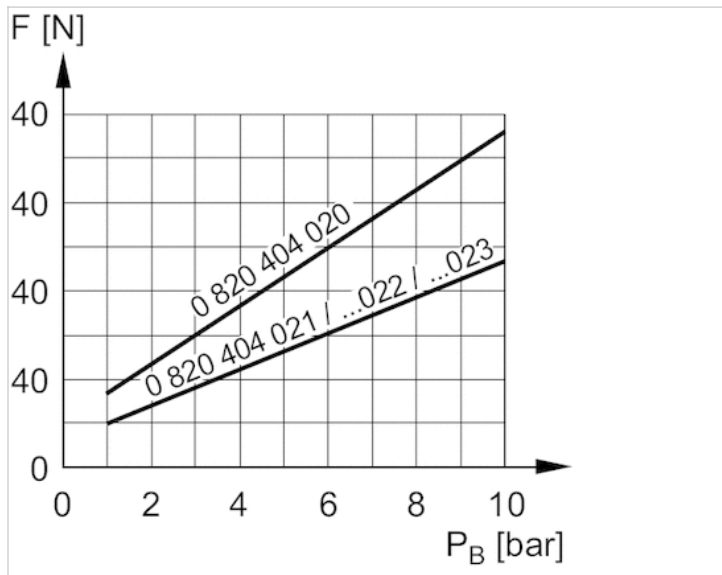

F = actuating force

P_B = Working pressure

3/2-directional valve, Series AP







- Qn 1►2 = 190 l/min
- Qn 2►3 = 150 l/min
- Compressed air connection output M5
- Pipe connection



Version	Poppet valve
Activation	Mechanical
Switching principle	3/2
Working pressure min./max.	0 ... 10 bar
Ambient temperature min./max.	-30 ... 80 °C
Medium temperature min./max.	-30 ... 80 °C
Medium	Compressed air
Max. particle size	5 µm
Oil content of compressed air	0 ... 5 mg/m ³
Weight	See table below

An example configuration is illustrated.
The delivered product may thus deviate from the illustration.

Technical data

Part No.		Actuating element	Compressed air connection type	Compressed air connection Input
0820408001		Plunger	Internal thread	M5
0820408002		Roller	Internal thread	M5
0820408003		Roller lever, one-way trip	Internal thread	M5
0820408004		Push button	Internal thread	M5
0820408005		Lever	Internal thread	M5
R450055451		panel installation	Internal thread	M5

Part No.	Compressed air connection Output	Flow		Weight	Fig.	
		Qn 1 ► 2	Qn 2 ► 3			
0820408001	M5	190 l/min	150 l/min	0.036 kg	Fig. 1	-
0820408002	M5	190 l/min	150 l/min	0.05 kg	Fig. 2	-
0820408003	M5	190 l/min	150 l/min	0.055 kg	Fig. 3	-
0820408004	M5	190 l/min	150 l/min	0.05 kg	Fig. 4	-
0820408005	M5	190 l/min	150 l/min	0.042 kg	Fig. 5	-
R450055451	M5	190 l/min	150 l/min	0.068 kg	Fig. 6	1)

Nominal flow Qn at 6 bar and $\Delta p = 1$ bar

1) Please order control button separately., Cannot be combined with mushroom button with detent and rotary release R412012741

Technical information

Material	
Housing	Aluminum
Seals	Acrylonitrile butadiene rubber

Dimensions, Fig. 2

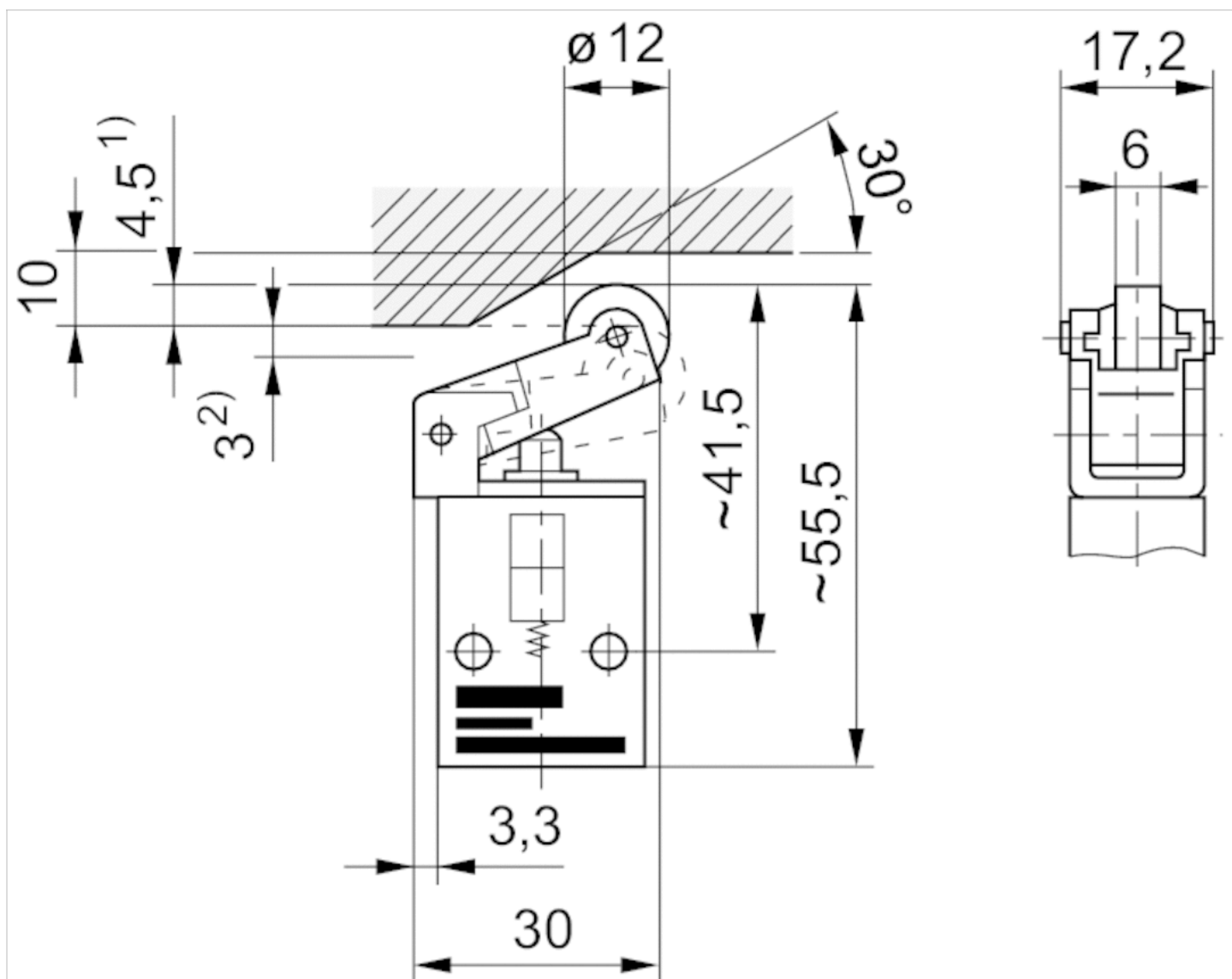

1) actuating stroke

2) overstroke

Dimensions, Fig. 3

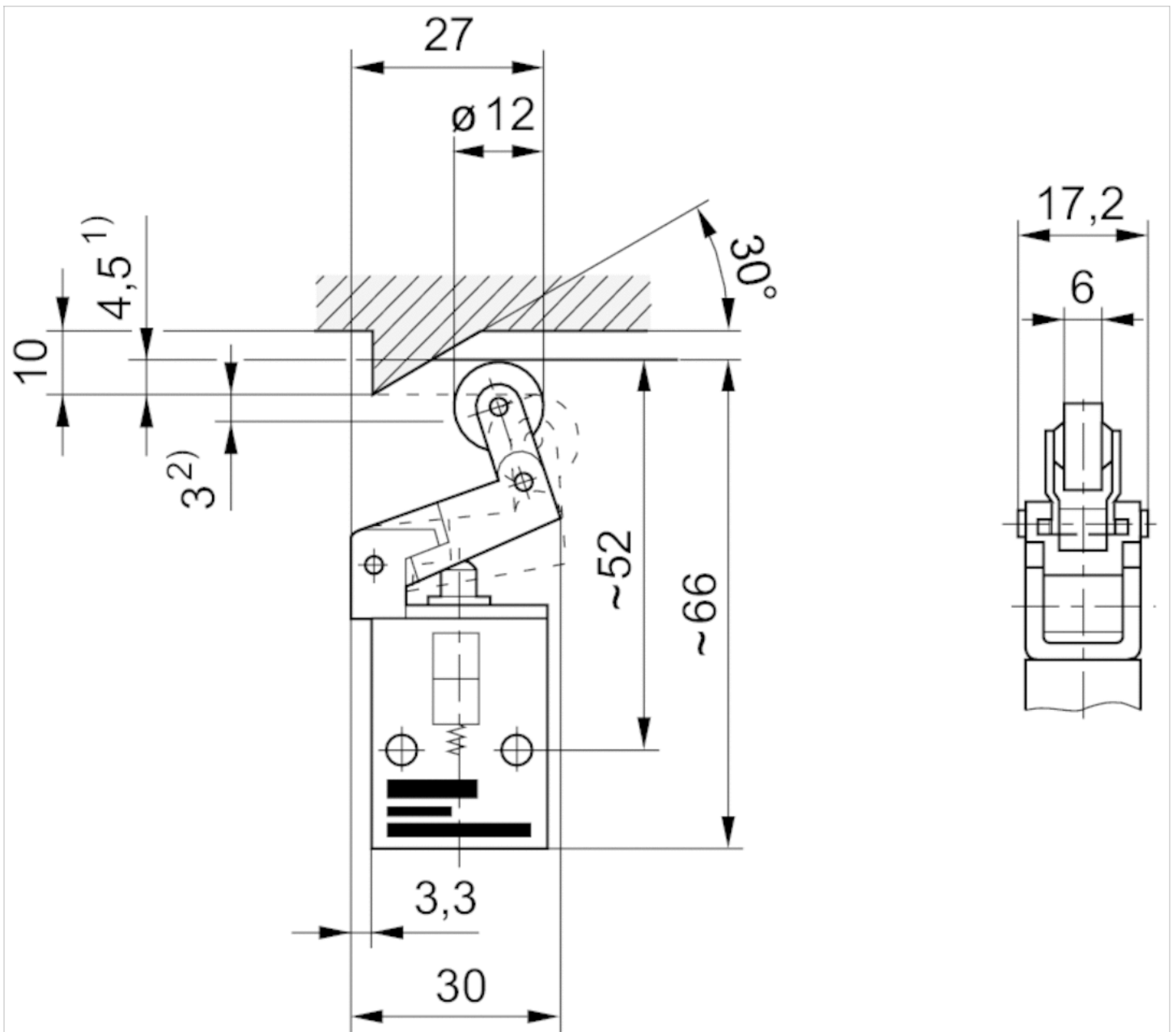

- 1) actuating stroke
- 2) overstroke

Dimensions, Fig. 4

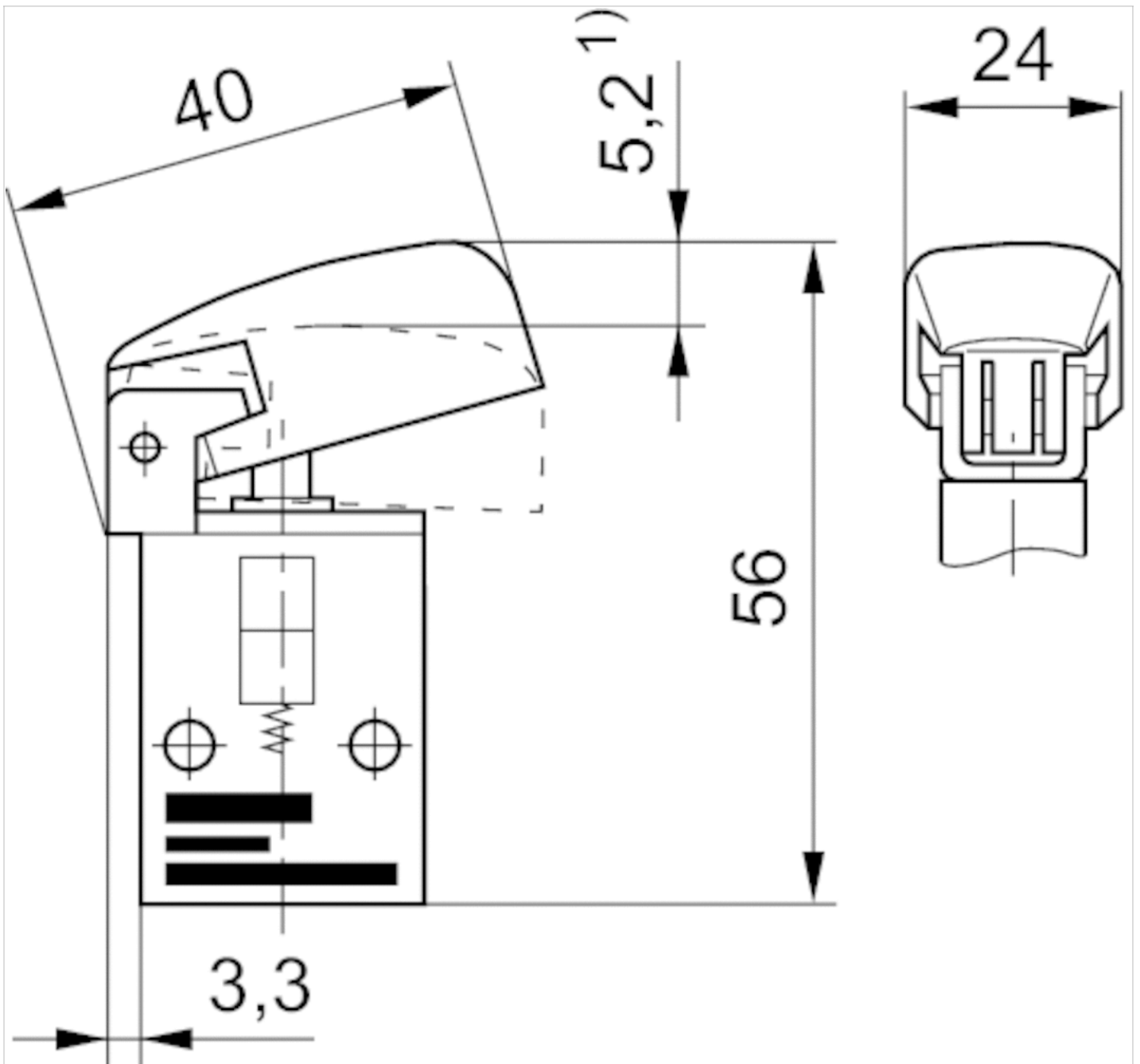

1) actuating stroke

Dimensions, Fig. 5

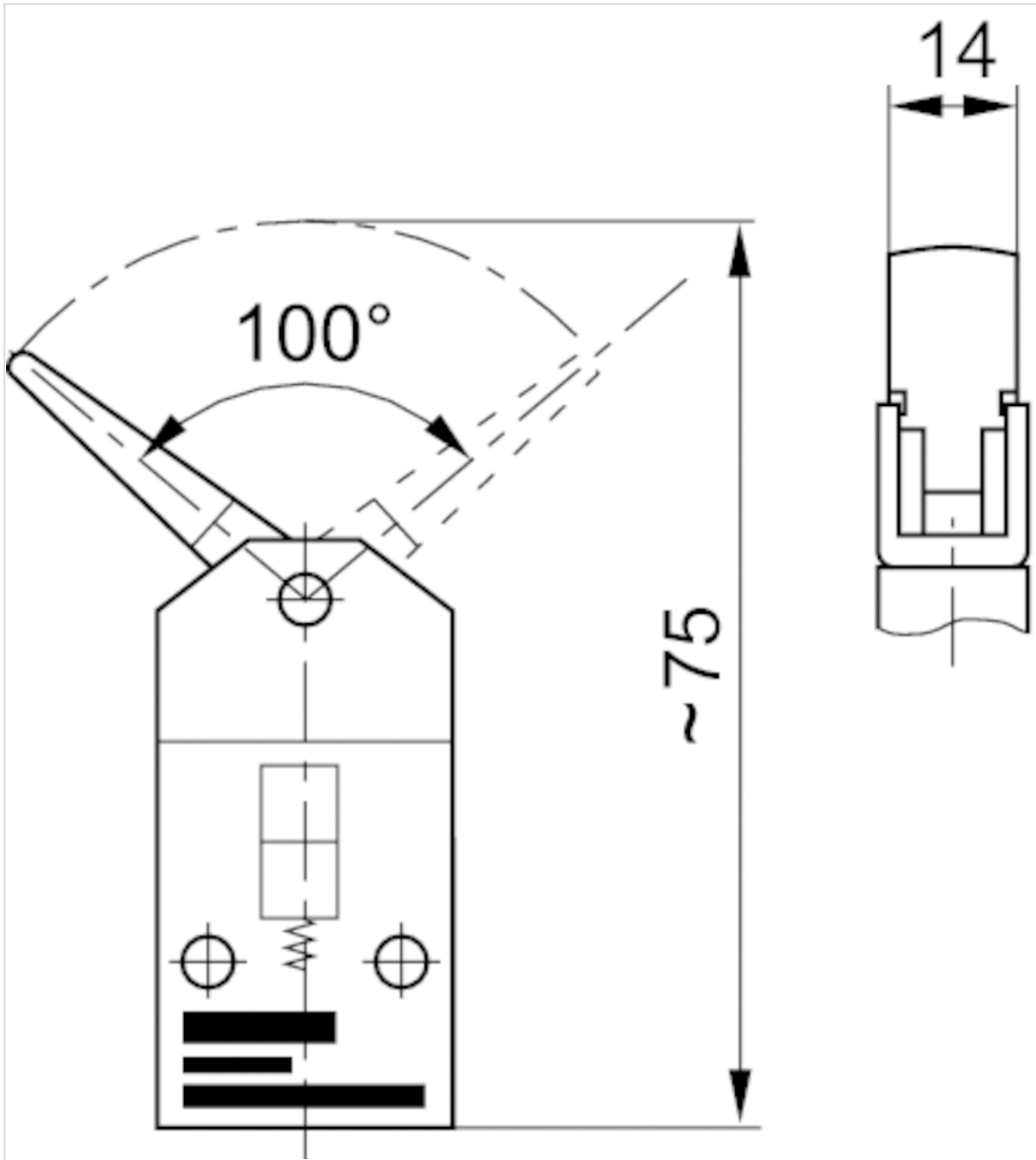

actuating torque: 5 Ncm

Dimensions, Fig. 6

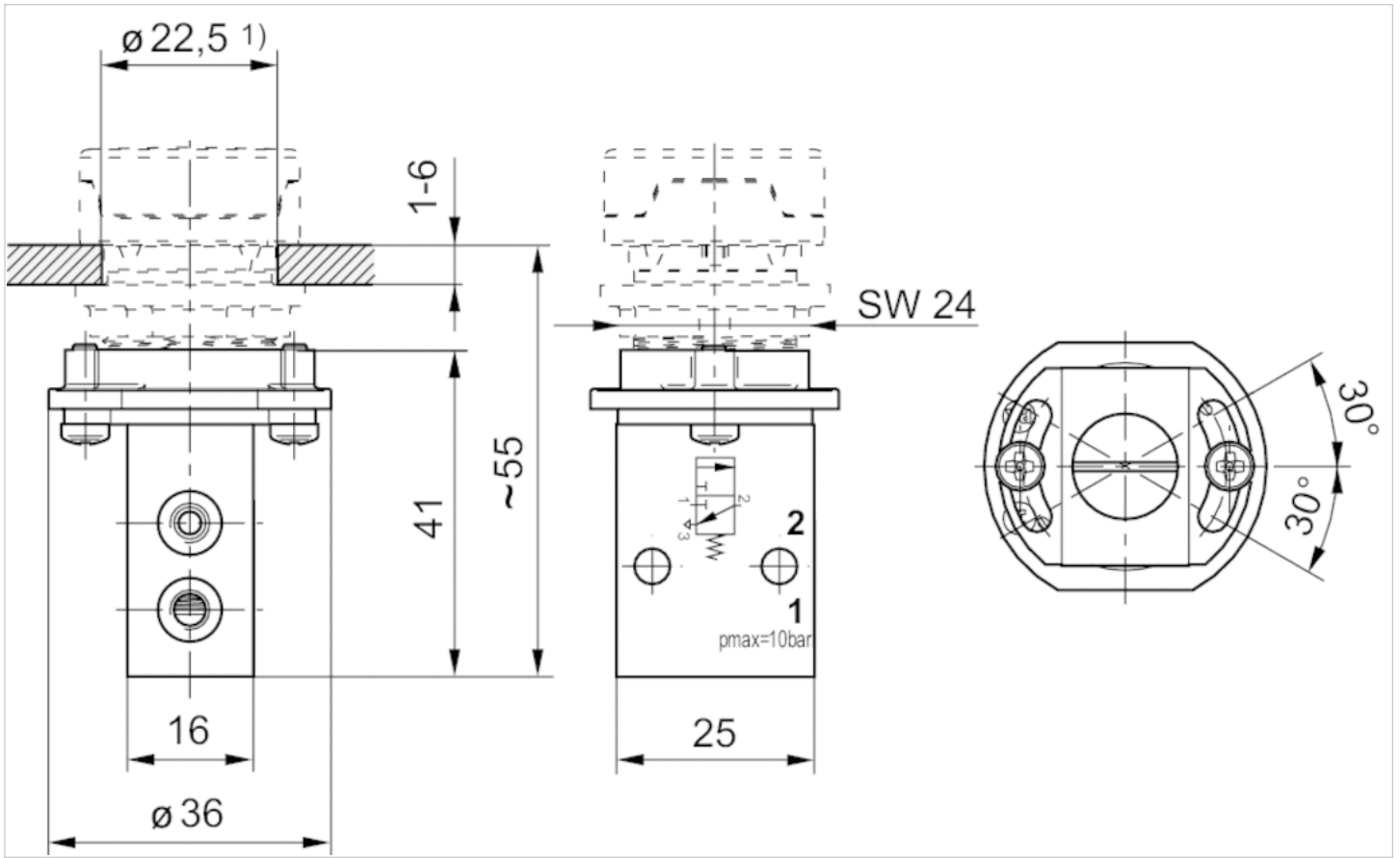

1) cut-out in the front plate

Dimensions, cut-out in the front plate

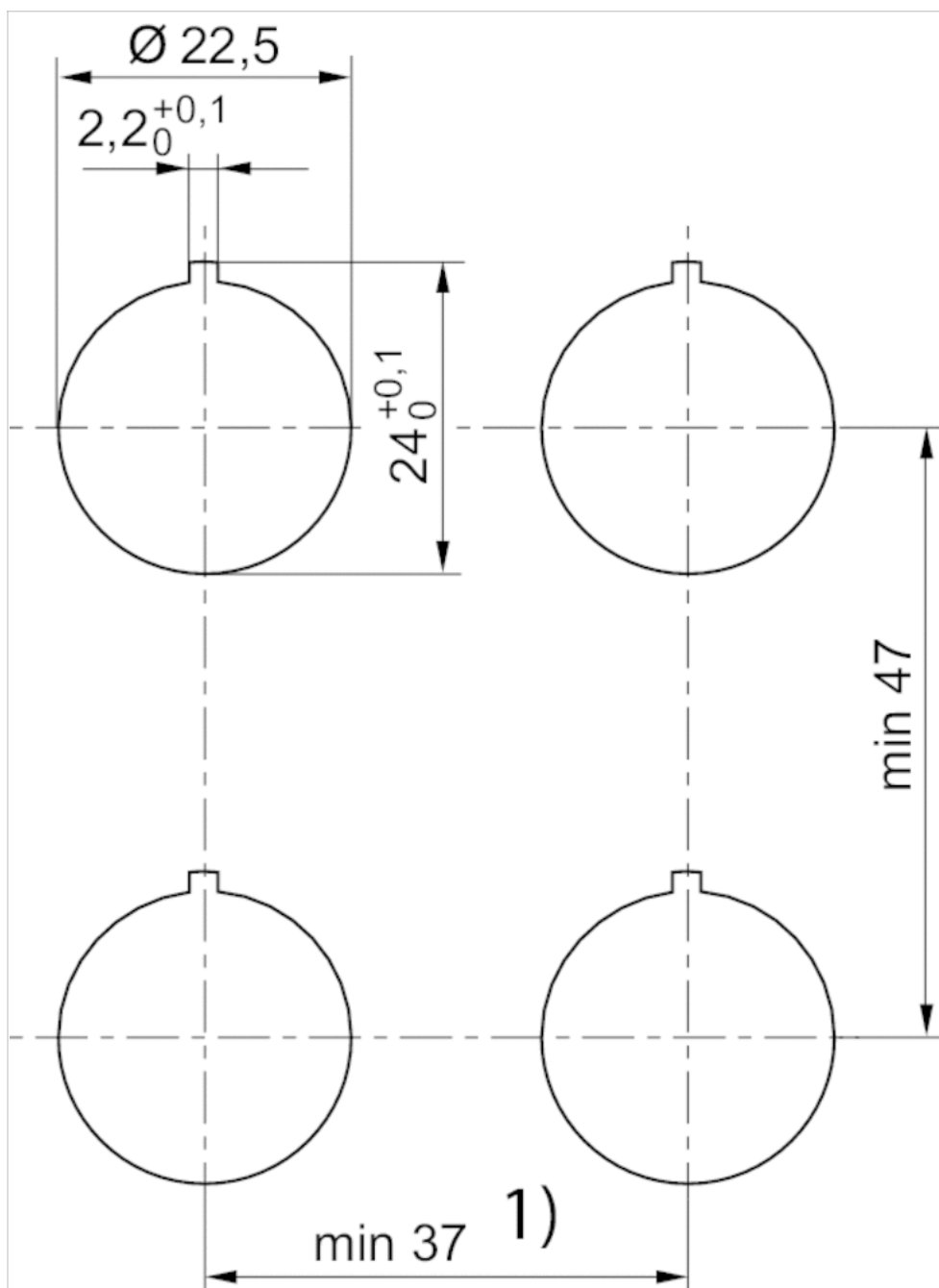

1) For the mushroom buttons (R412012738, R412012739, R412012740) a minimum distance 41 mm must be ensured.

Diagrams

Actuating force+

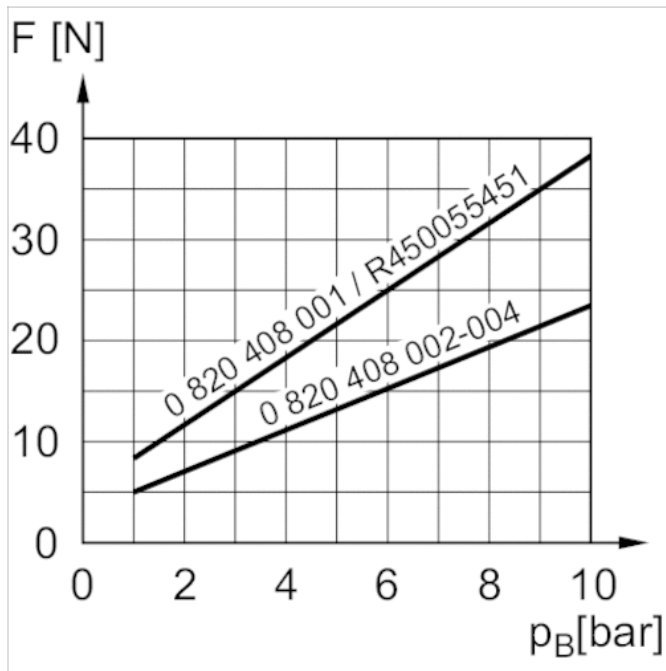

F = actuating force

p_B = Working pressure

3/2-directional valve, Series AP







- Qn 1►2 = 250 l/min
- Qn 2►3 = 150 l/min
- Compressed air connection output G 1/8
- Pipe connection



Version	Poppet valve
Activation	Mechanical
Switching principle	3/2
Working pressure min./max.	0 ... 10 bar
Ambient temperature min./max.	-30 ... 80 °C
Medium temperature min./max.	-30 ... 80 °C
Medium	Compressed air
Max. particle size	5 µm
Oil content of compressed air	0 ... 5 mg/m ³
Weight	See table below

An example configuration is illustrated.
The delivered product may thus deviate from the illustration.

Technical data

Part No.		Actuating element	Compressed air connection type	Compressed air connection Input
0820402101		Plunger	Internal thread	G 1/8
0820402102		Roller	Internal thread	G 1/8
0820402103		Roller lever, one-way trip	Internal thread	G 1/8
0820402104		Push button	Internal thread	G 1/8
0820402105		Lever	Internal thread	G 1/8
R450055452		panel installation	Internal thread	G 1/8

Part No.	Compressed air connection Output	Compressed air connection Exhaust	Flow		Weight
			Qn 1 ► 2	Qn 2 ► 3	
0820402101	G 1/8	G 1/8	250 l/min	150 l/min	0.07 kg
0820402102	G 1/8	G 1/8	250 l/min	150 l/min	0.08 kg
0820402103	G 1/8	G 1/8	250 l/min	150 l/min	0.085 kg
0820402104	G 1/8	G 1/8	250 l/min	150 l/min	0.085 kg
0820402105	G 1/8	G 1/8	250 l/min	150 l/min	0.075 kg
R450055452	G 1/8	G 1/8	250 l/min	150 l/min	0.09 kg

Part No.	Fig.	
0820402101	Fig. 1	-
0820402102	Fig. 2	-
0820402103	Fig. 3	-
0820402104	Fig. 4	-
0820402105	Fig. 5	-
R450055452	Fig. 6	1)

Nominal flow Qn at 6 bar and $\Delta p = 1$ bar

1) Please order control button separately., Cannot be combined with mushroom button with detent and rotary release R412012741

Technical information

Housing	Aluminum
---------	----------

Dimensions

Dimensions, Fig. 1, Basic valve

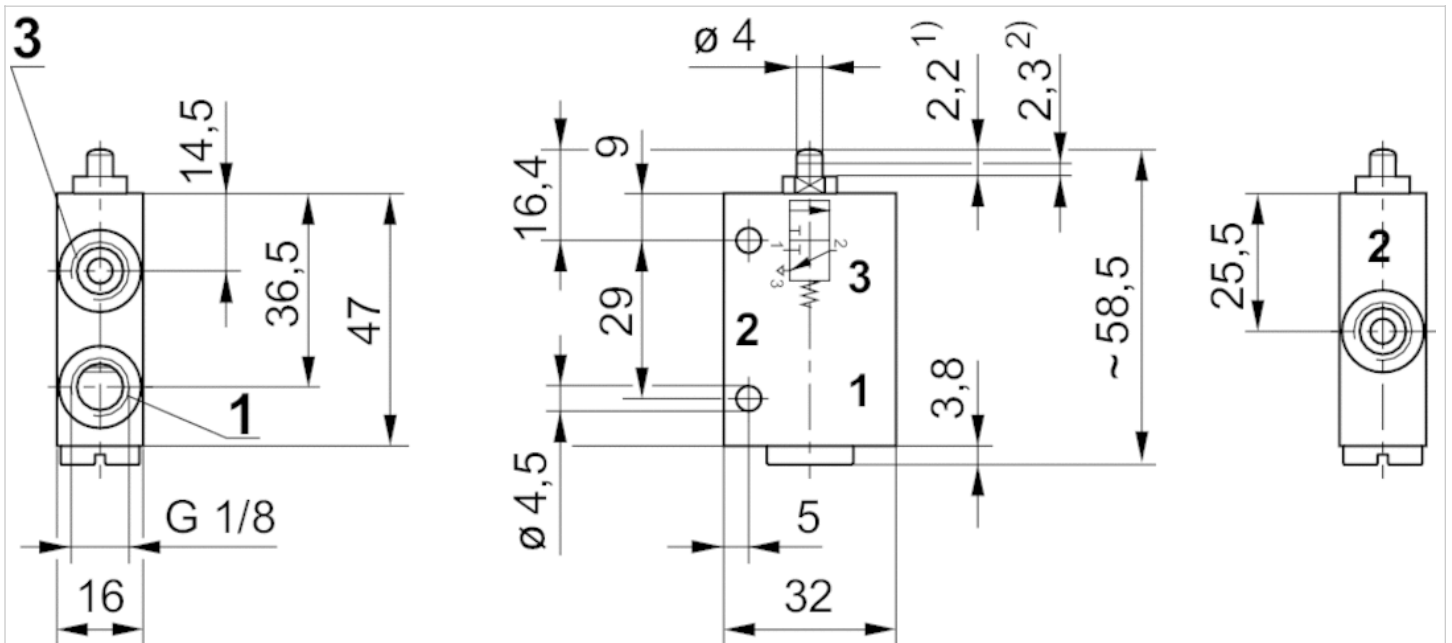

1) actuating stroke

2) overstroke

Dimensions of basic valve apply to all types of actuation.

Dimensions, Fig. 2

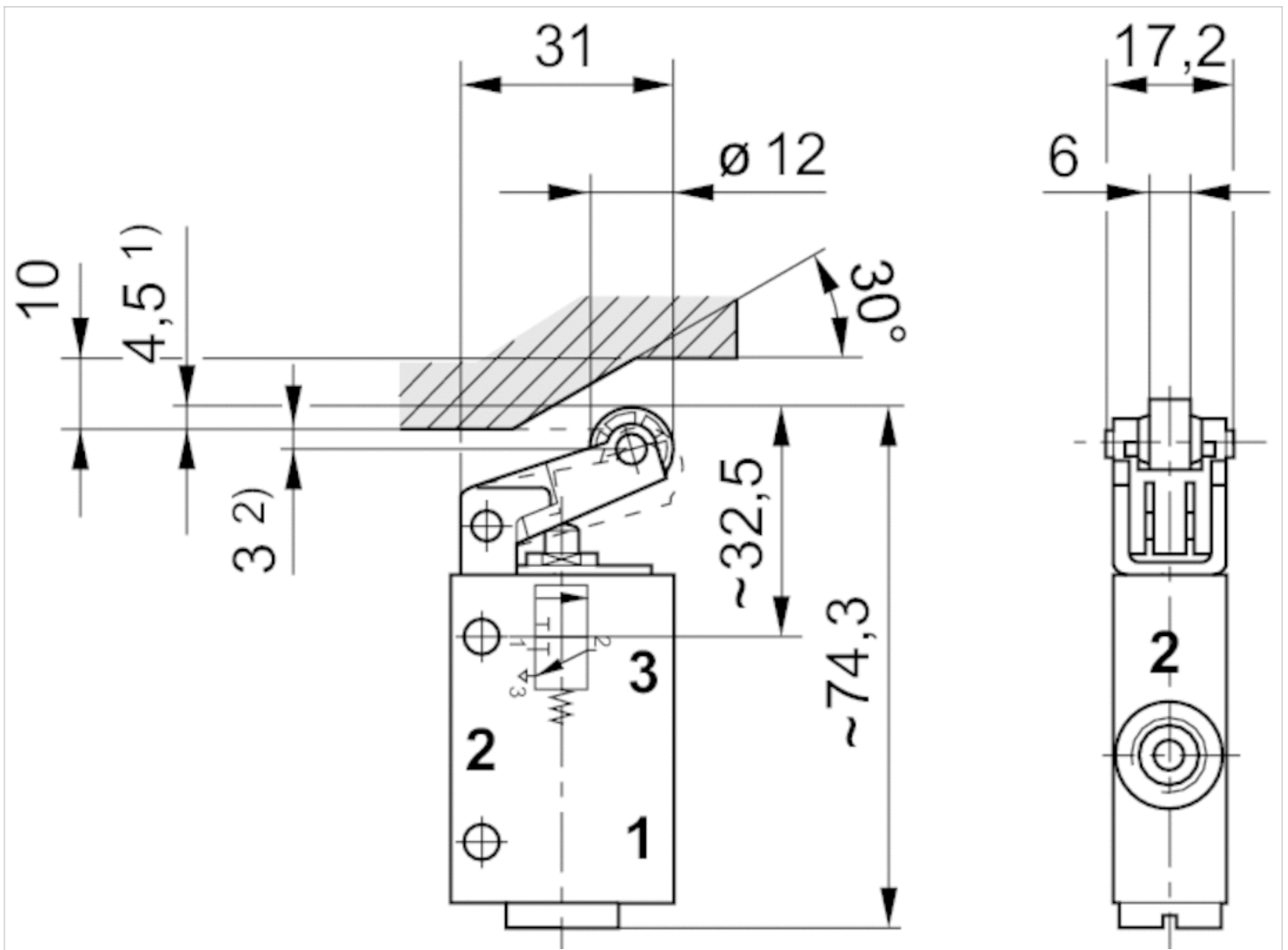

- 1) actuating stroke
- 2) overstroke

Dimensions, Fig. 3

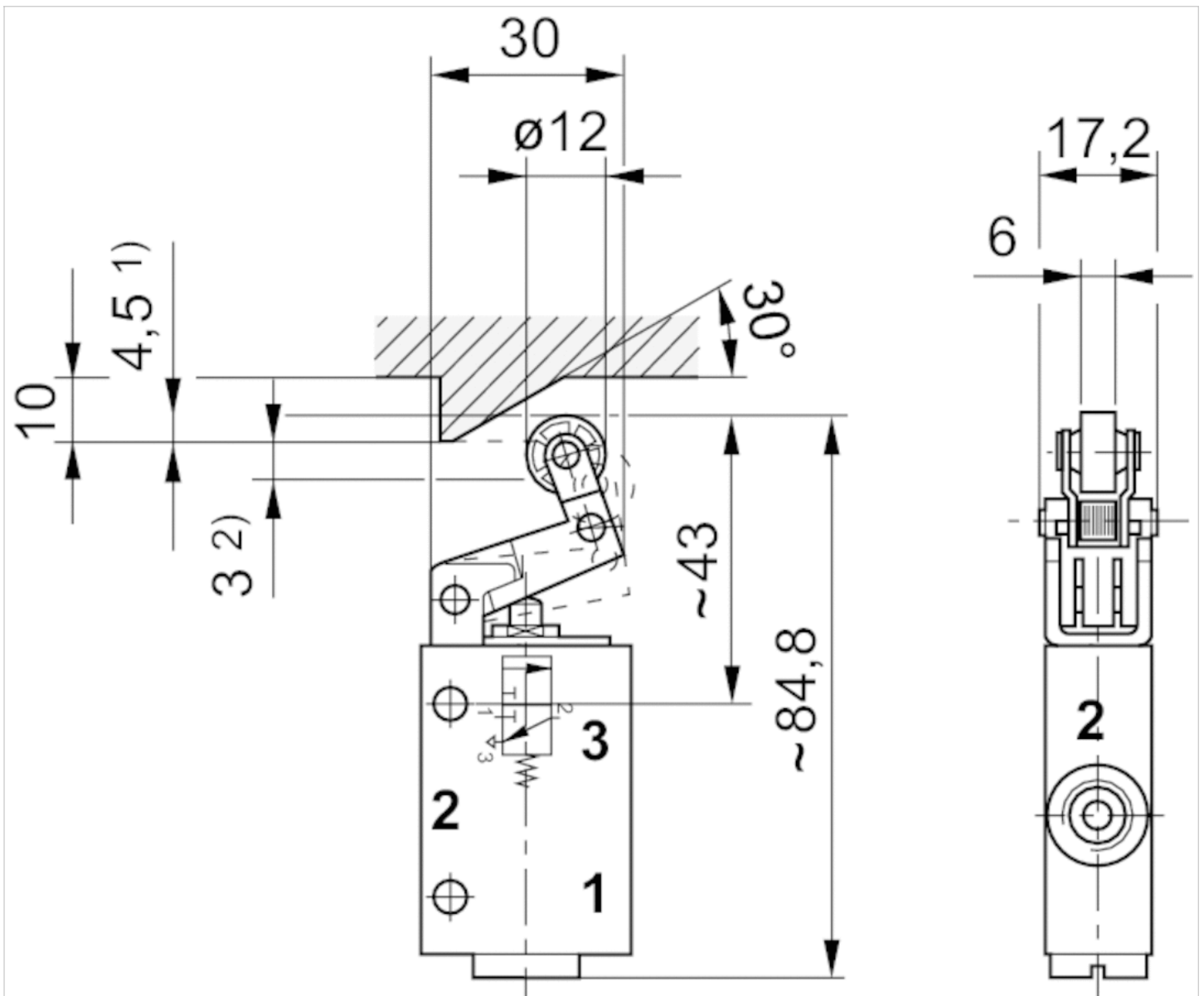

- 1) actuating stroke
- 2) overstroke

Dimensions, Fig. 4

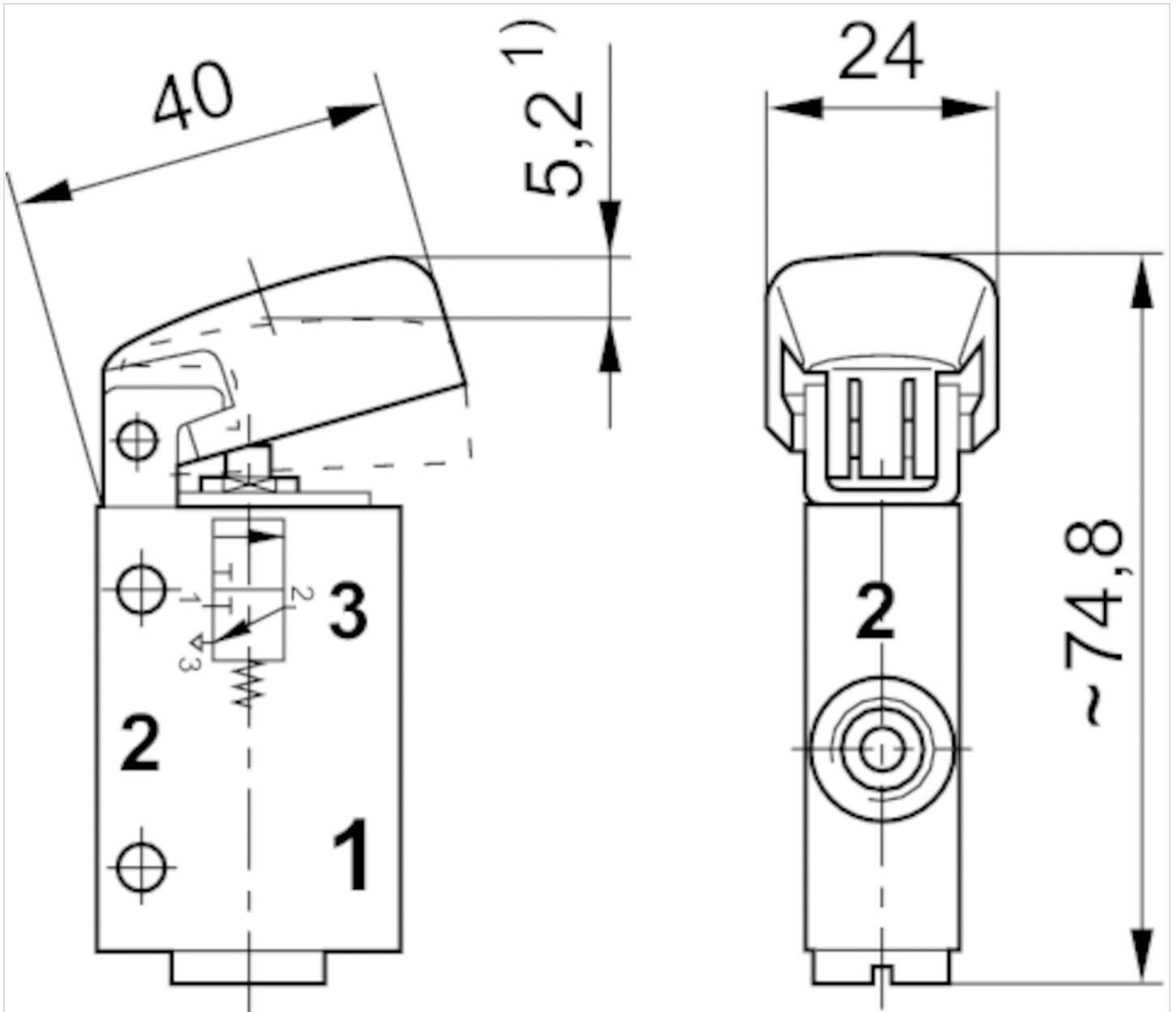

1) actuating stroke

Dimensions, Fig. 5

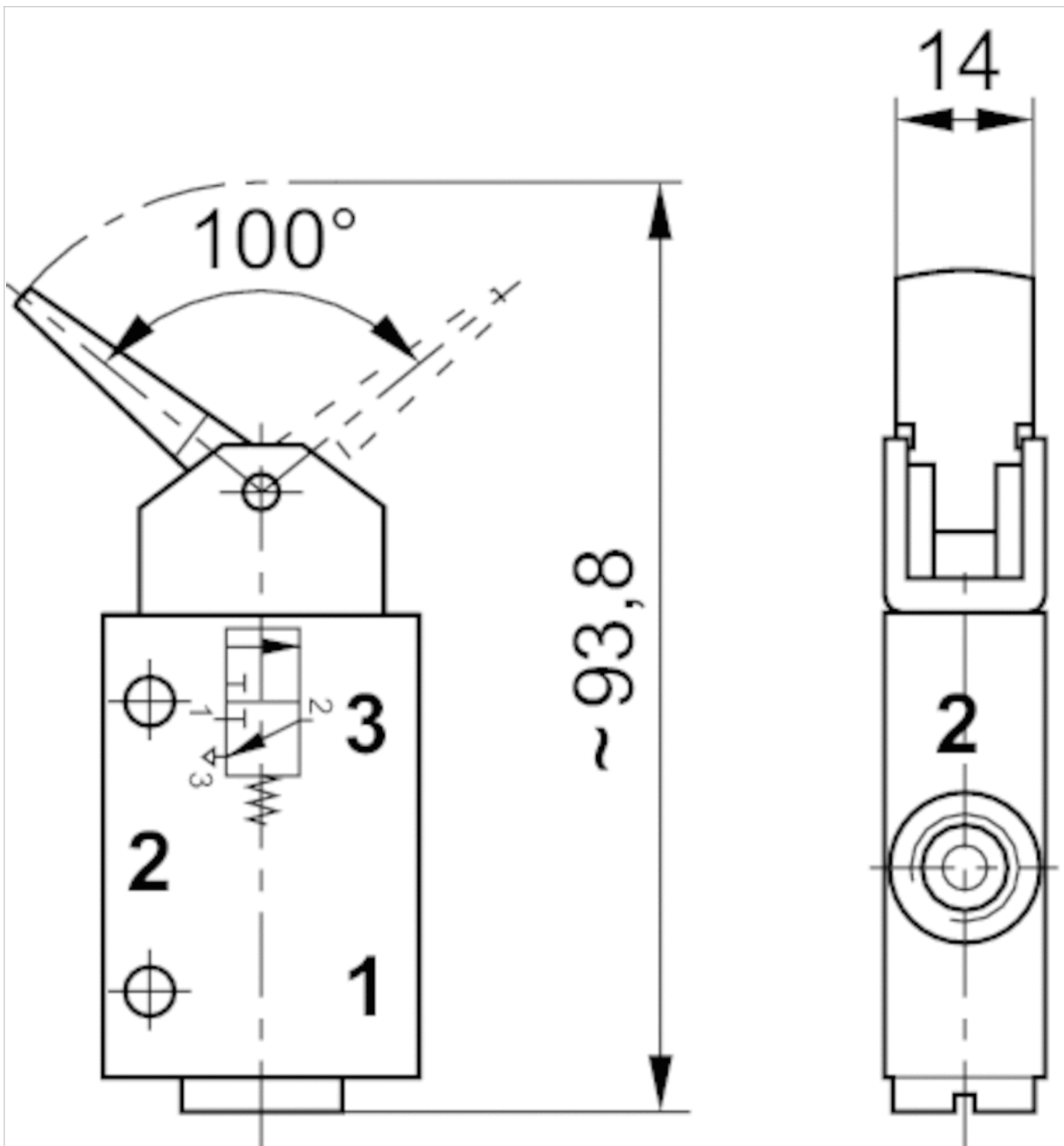

Dimensions, Fig. 6

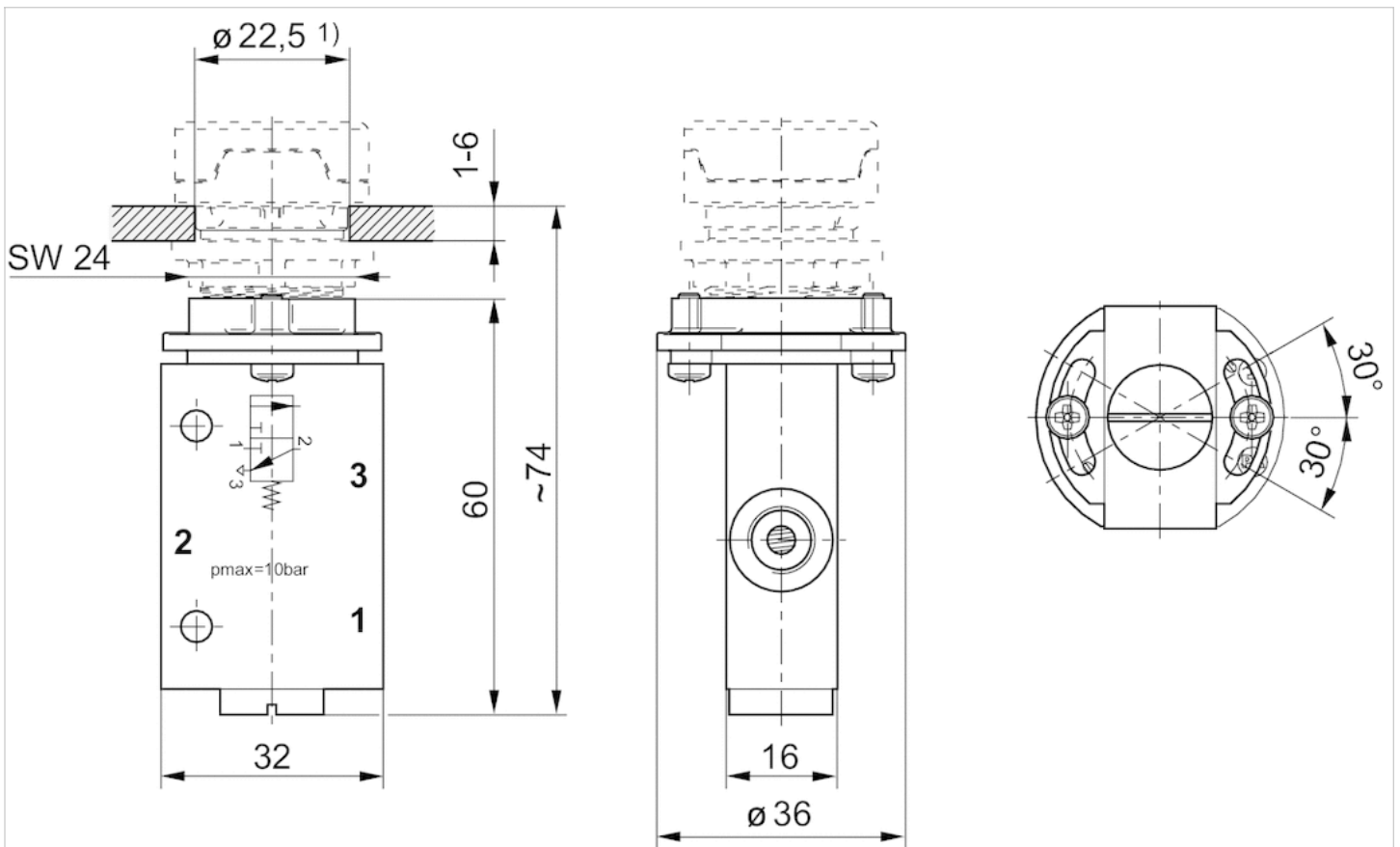

1) cut-out in the front plate

Dimensions, cut-out in the front plate

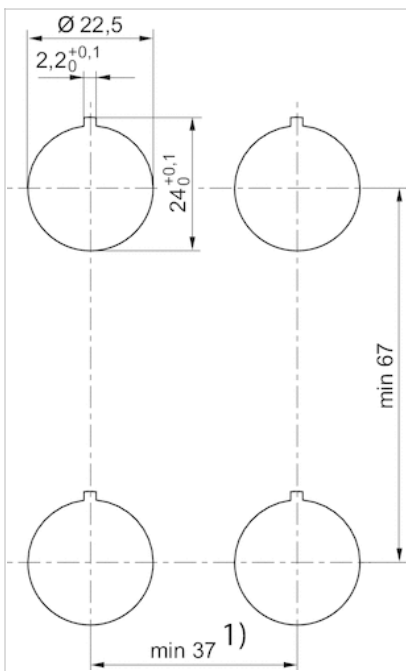

1) For the mushroom buttons (R412012738, R412012739, R412012740) a minimum distance 41 mm must be ensured.

Diagrams

Actuating force+

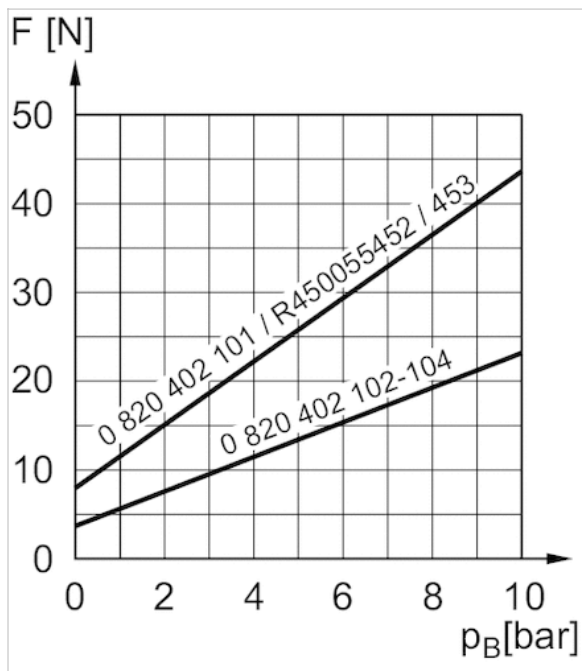

F = actuating force

p_B = Working pressure

3/2-directional valve, Series AP







- Qn = 550 l/min
- Compressed air connection output G 1/4
- Pipe connection



Version	Poppet valve
Activation	Mechanical
Switching principle	3/2
Nominal flow Qn	550 l/min
Working pressure min./max.	0 ... 10 bar
Ambient temperature min./max.	-30 ... 80 °C
Medium temperature min./max.	-30 ... 80 °C
Medium	Compressed air
Max. particle size	5 µm
Oil content of compressed air	0 ... 5 mg/m ³
Weight	See table below

An example configuration is illustrated. The delivered product may thus deviate from the illustration.

Technical data

Part No.		Actuating element	Compressed air connection type	Compressed air connection Input
0820400001		Plunger	Internal thread	G 1/4
0820400002		Roller	Internal thread	G 1/4
0820400003		Roller lever, one-way trip	Internal thread	G 1/4
0820400004		Push button	Internal thread	G 1/4
0820400005		Lever	Internal thread	G 1/4
0820400006		Pedal	Internal thread	G 1/4
0820400008		Pedal, with detent	Internal thread	G 1/4

Part No.	Compressed air connection Output	Compressed air connection Exhaust	Material actuating control
0820400001	G 1/4	G 1/4	Steel
0820400002	G 1/4	G 1/4	Polyoxymethylene
0820400003	G 1/4	G 1/4	Polyoxymethylene Steel
0820400004	G 1/4	G 1/4	Aluminum
0820400005	G 1/4	G 1/4	Steel Polyamide
0820400006	G 1/4	G 1/4	Aluminum
0820400008	G 1/4	G 1/4	Aluminum

Part No.	Weight	Fig.
0820400001	0.165 kg	Fig. 1
0820400002	0.265 kg	Fig. 2
0820400003	0.28 kg	Fig. 3
0820400004	0.29 kg	Fig. 4
0820400005	0.27 kg	Fig. 5
0820400006	1.2 kg	Fig. 6

Dimensions, Fig. 2

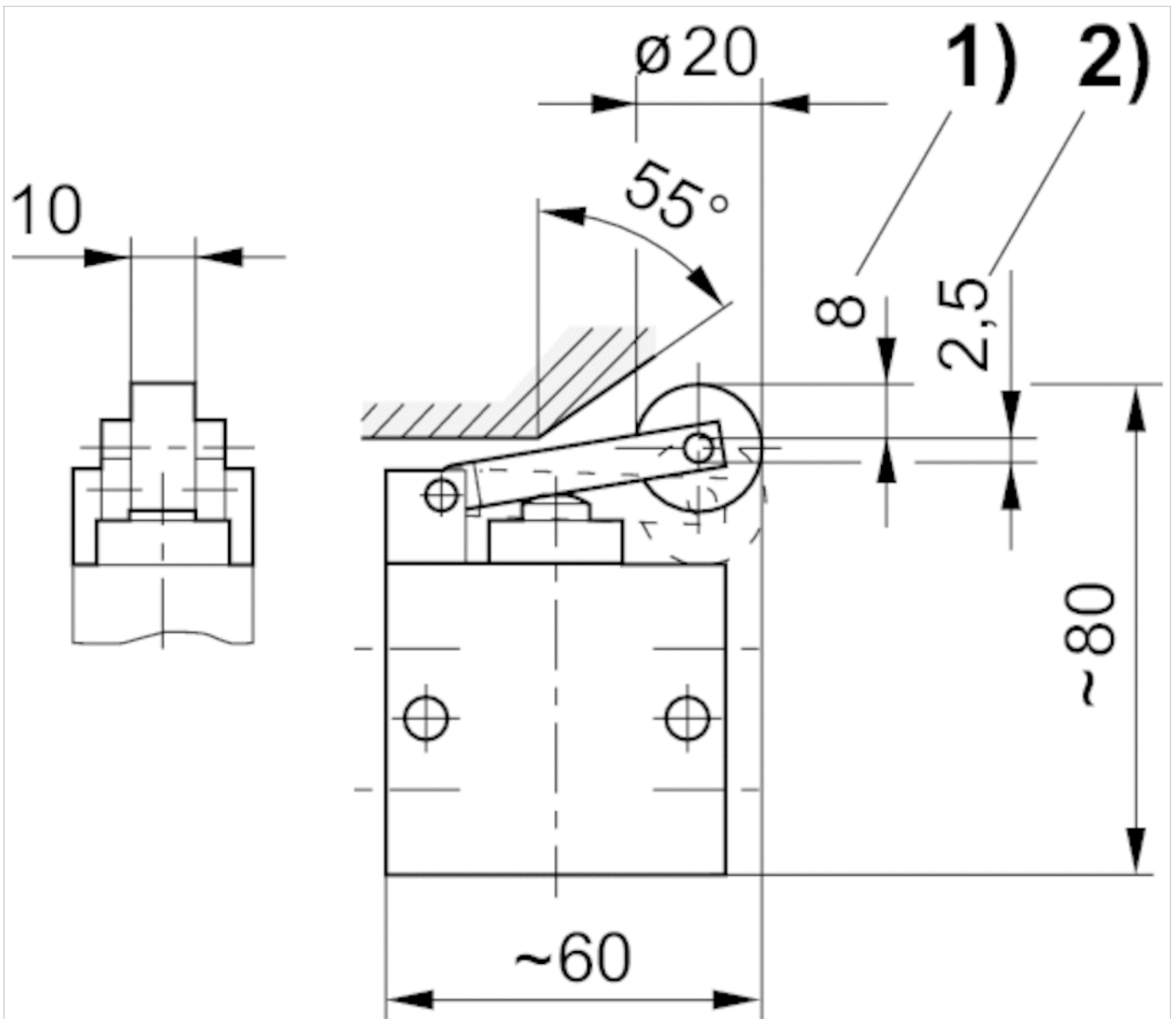

- 1) actuating stroke
- 2) overstroke

Dimensions, Fig. 3

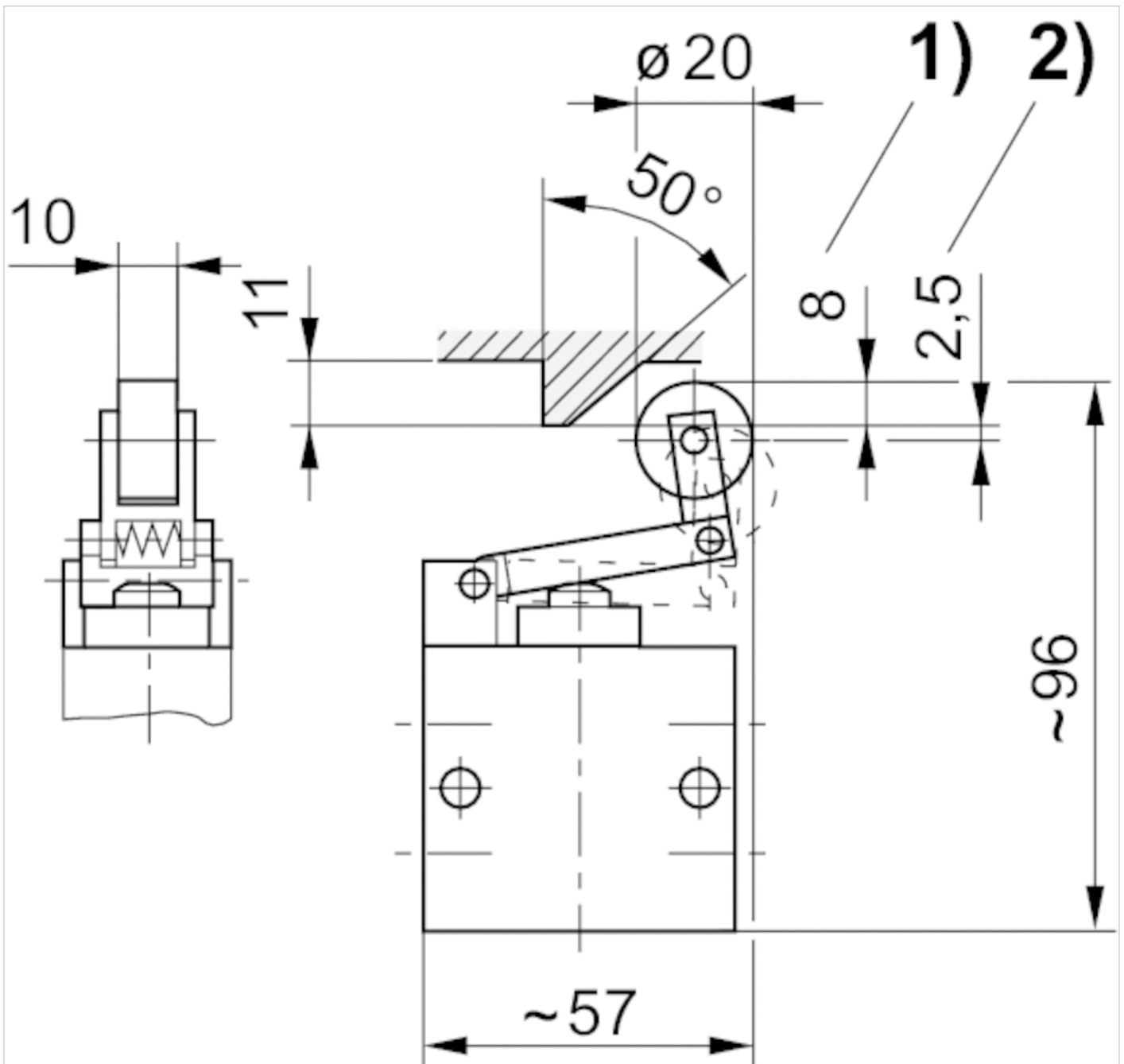

- 1) actuating stroke
- 2) overstroke

Dimensions, Fig. 4

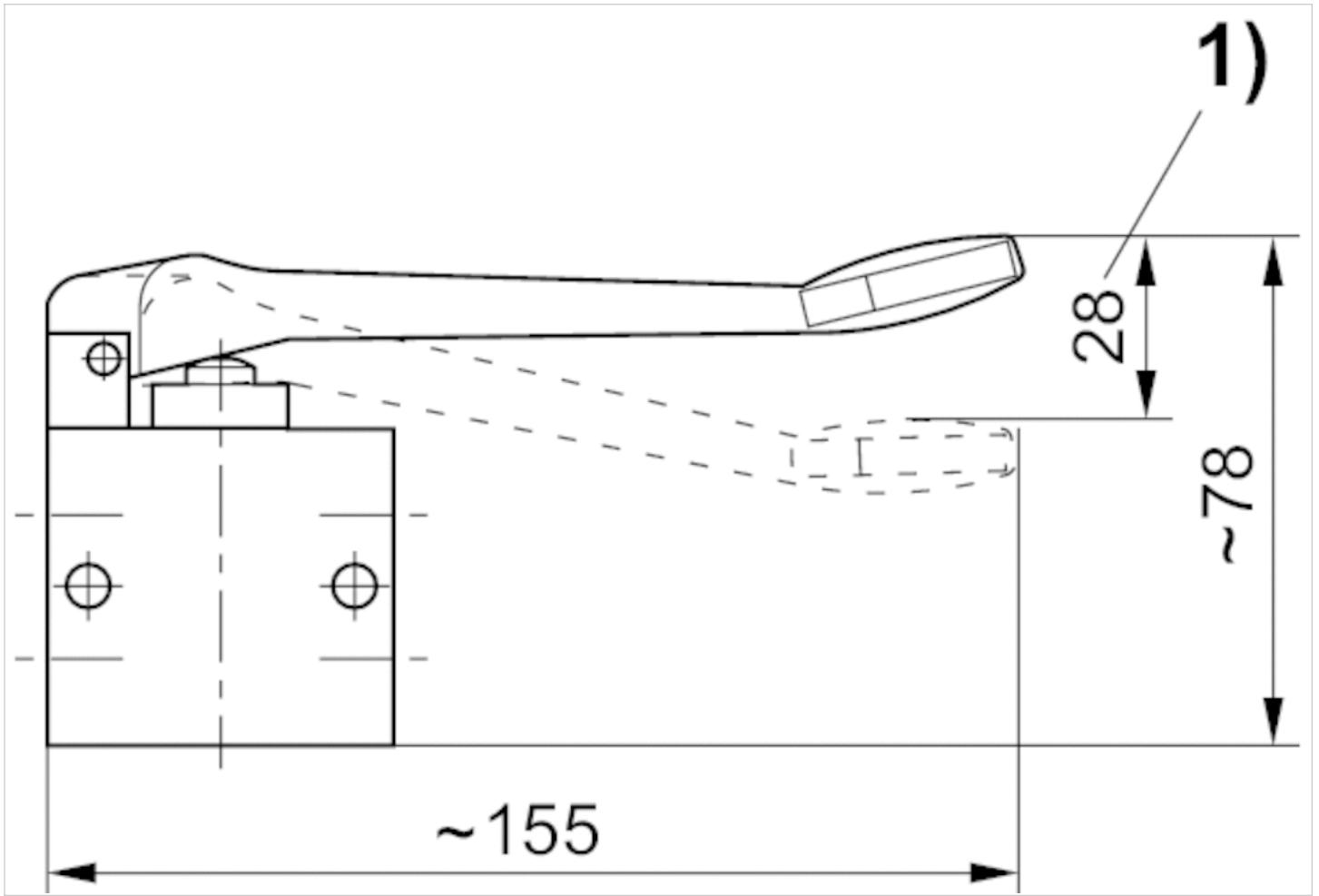

1) actuating stroke

Dimensions, Fig. 5

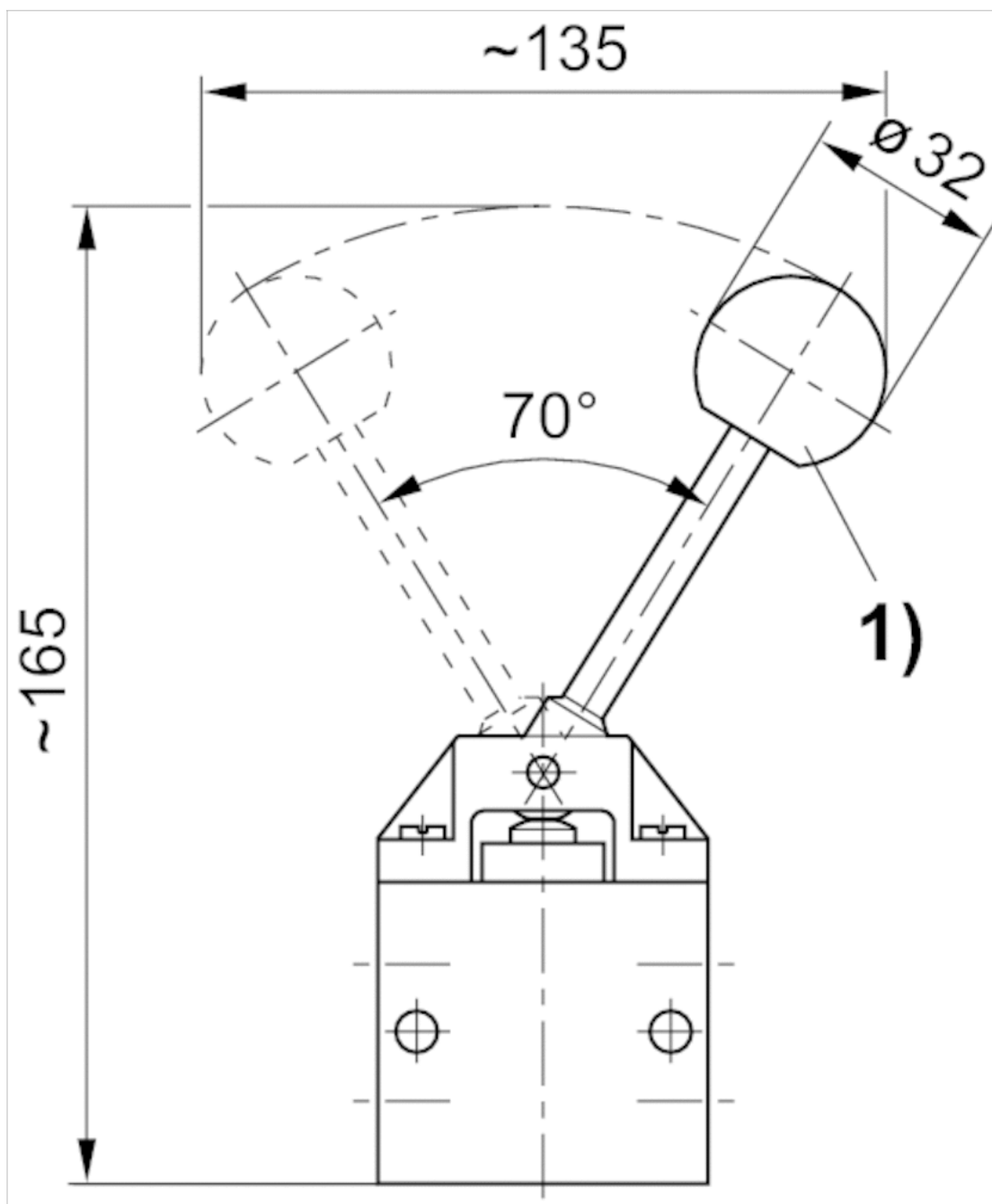

actuating torque: 40 Ncm

1) Ball

Dimensions, Fig. 6

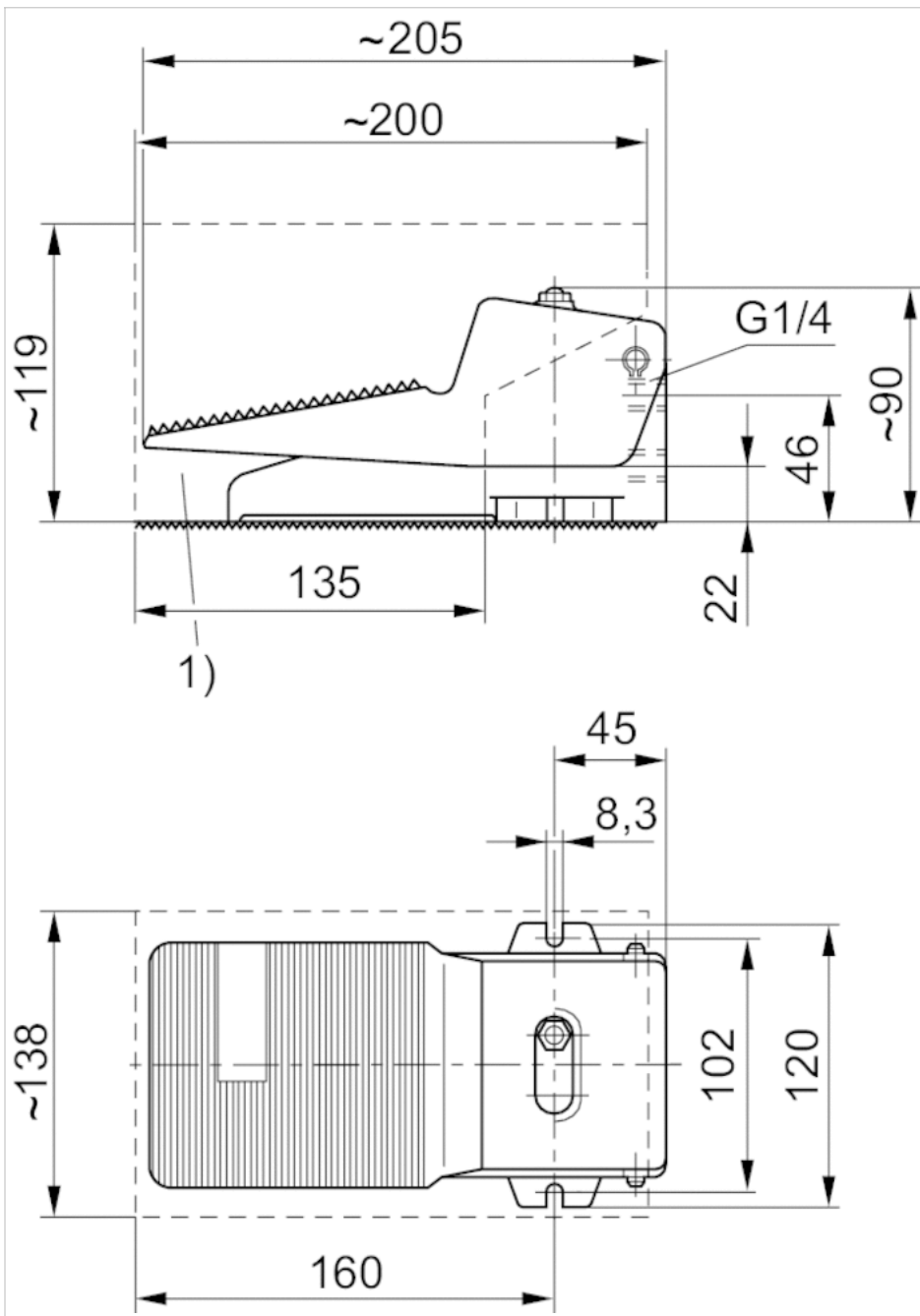

1) optional protective cover, part number 1828104001

Dimensions, Fig. 7

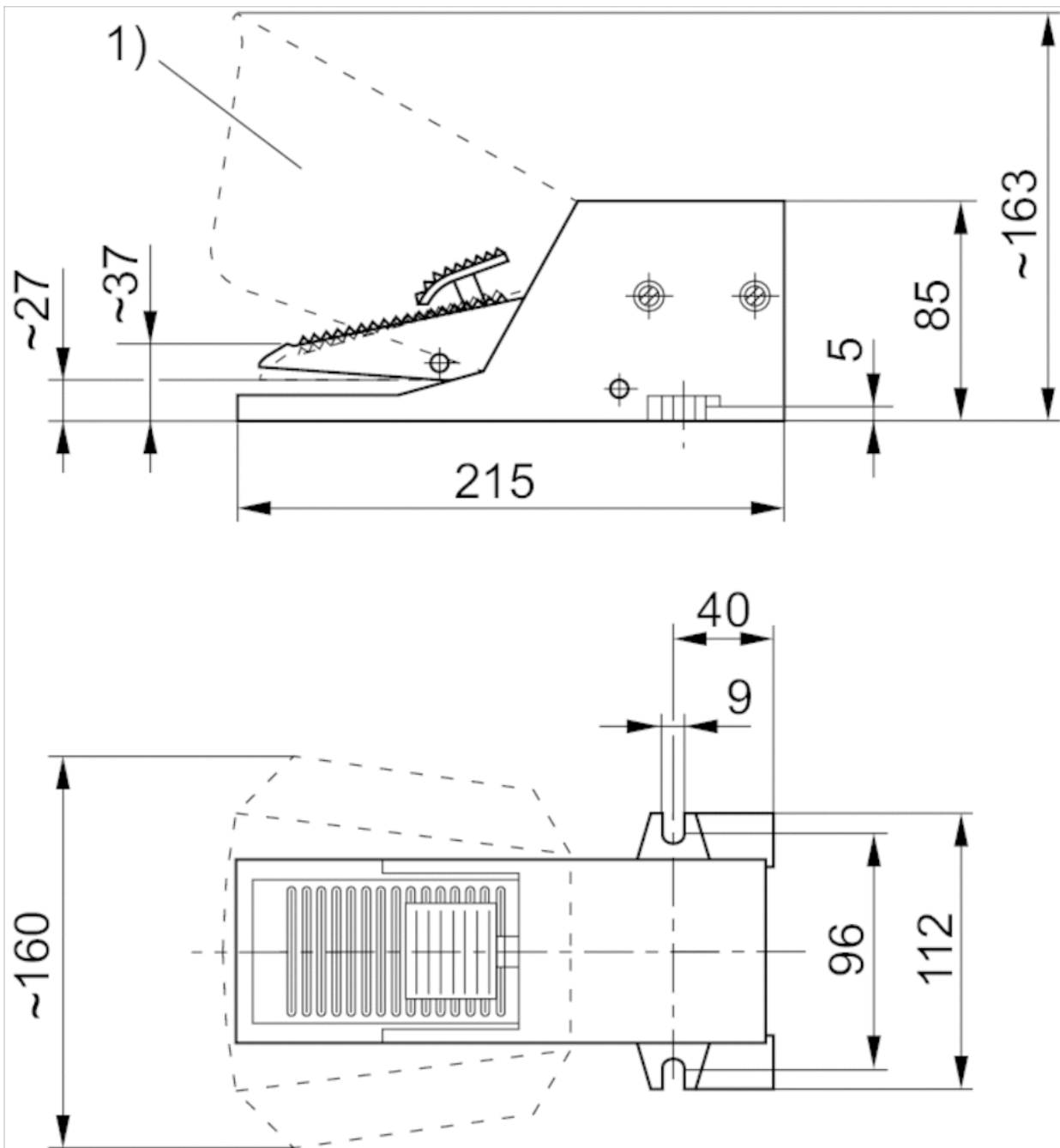

1) optional protective cover, part number 1828104002

Diagrams

Actuating force+, Compressed air at port 1

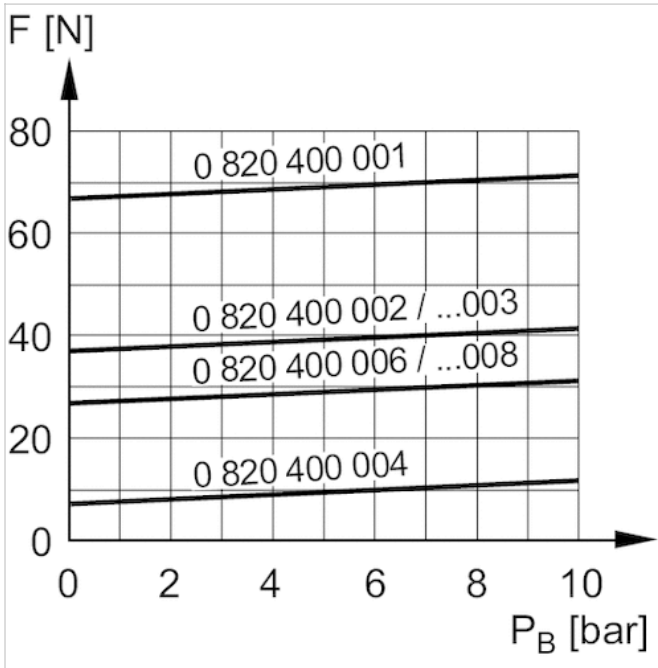

F = actuating force
 PB= Working pressure

Compressed air at port 3

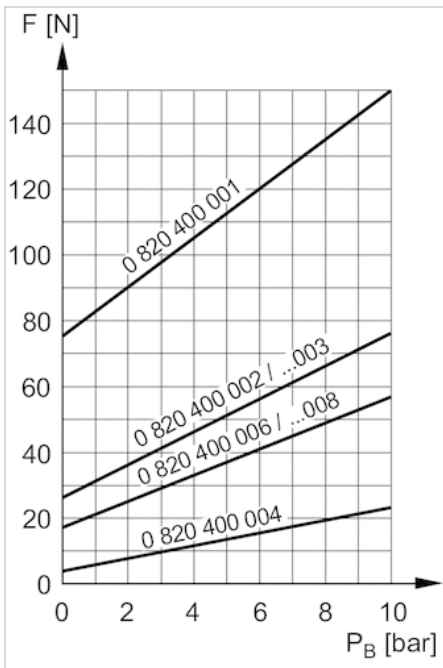

4/2-directional valve, Series AP







- Qn = 550 l/min
- Compressed air connection output G 1/4
- Pipe connection



Version	Poppet valve
Activation	Mechanical
Nominal flow Qn	550 l/min
Working pressure min./max.	0 ... 10 bar
Ambient temperature min./max.	-30 ... 80 °C
Medium temperature min./max.	-30 ... 80 °C
Medium	Compressed air
Max. particle size	5 µm
Oil content of compressed air	0 ... 5 mg/m ³
Weight	See table below

An example configuration is illustrated.
The delivered product may thus deviate from the illustration.

Technical data

Part No.		Actuating element	Compressed air connection type	Compressed air connection Input
0820401001		Plunger	Internal thread	G 1/4
0820401002		Roller	Internal thread	G 1/4
0820401004		Push button	Internal thread	G 1/4
0820401005		Lever	Internal thread	G 1/4
0820401006		Pedal	Internal thread	G 1/4
0820401008		Pedal, with detent	Internal thread	G 1/4

Part No.	Compressed air connection Output	Compressed air connection Exhaust	Material actuating control
0820401001	G 1/4	G 1/4	Steel
0820401002	G 1/4	G 1/4	Polyoxymethylene Steel
0820401004	G 1/4	G 1/4	Aluminum
0820401005	G 1/4	G 1/4	Steel Polyamide
0820401006	G 1/4	G 1/4	Aluminum
0820401008	G 1/4	G 1/4	Aluminum

Part No.	Weight	Fig.
0820401001	0.33 kg	Fig. 1
0820401002	0.5 kg	Fig. 2
0820401004	0.52 kg	Fig. 3
0820401005	0.53 kg	Fig. 4
0820401006	1.3 kg	Fig. 5
0820401008	1.42 kg	Fig. 6

Nominal flow Qn at 6 bar and $\Delta p = 1$ bar

Technical information

Housing	Aluminum
Actuating element	Steel Polyoxymethylene, Steel Aluminum Steel, Polyamide

Dimensions

Dimensions, Fig. 1

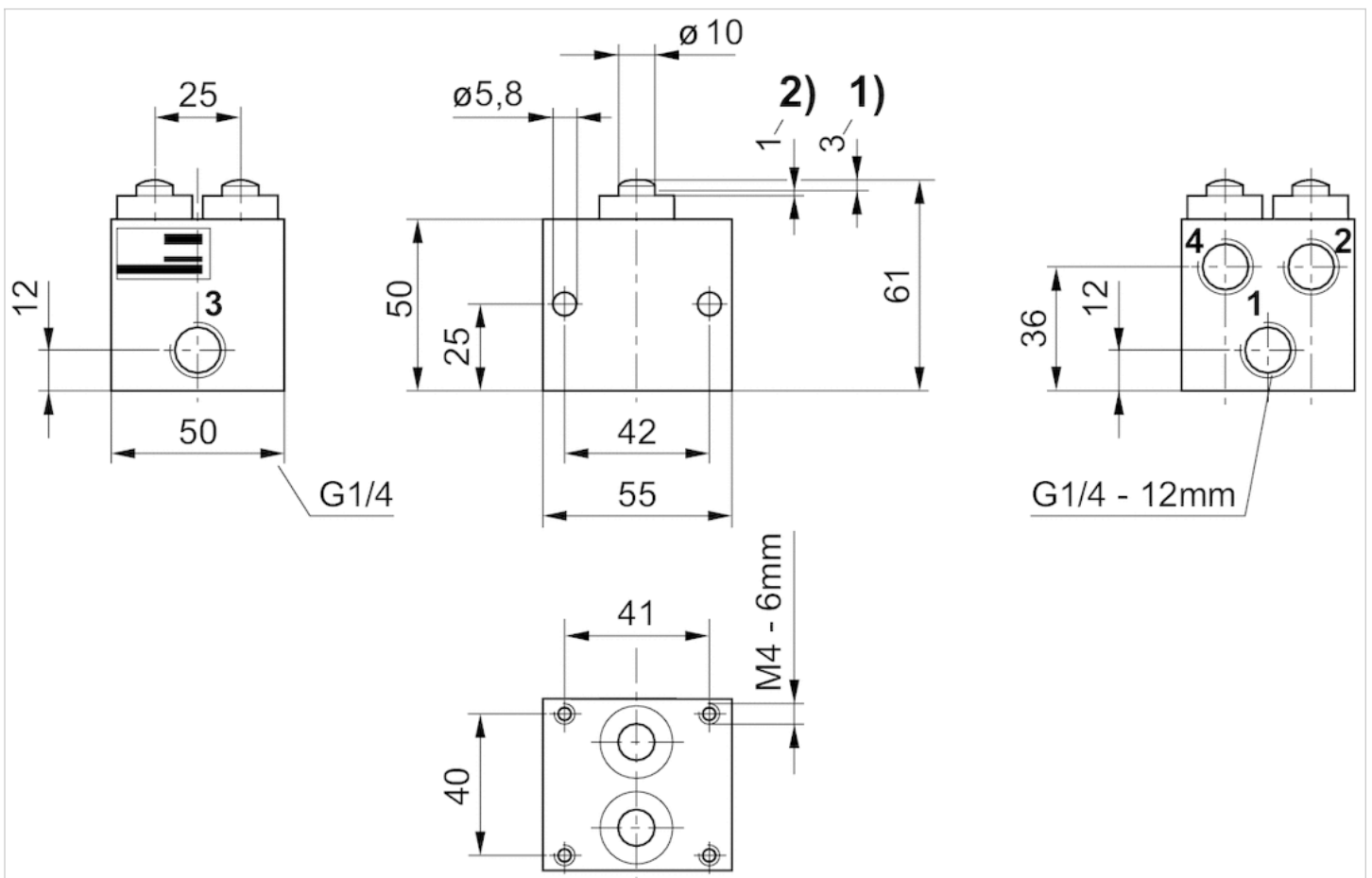

1) actuating stroke

2) overstroke

Dimensions of basic valve apply to all types of actuation.

Dimensions, Fig. 2

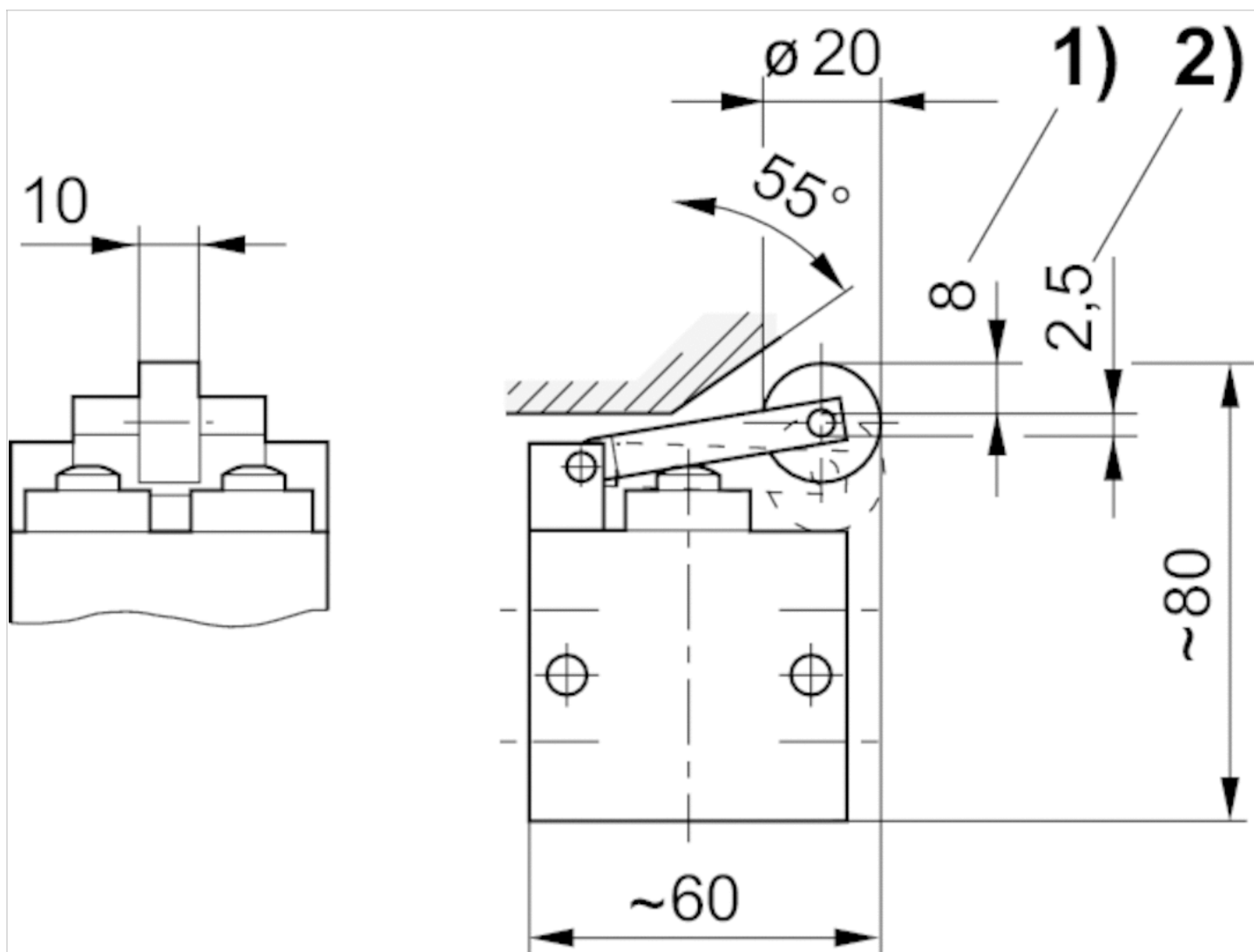

1) actuating stroke

2) overstroke

Dimensions, Fig. 3

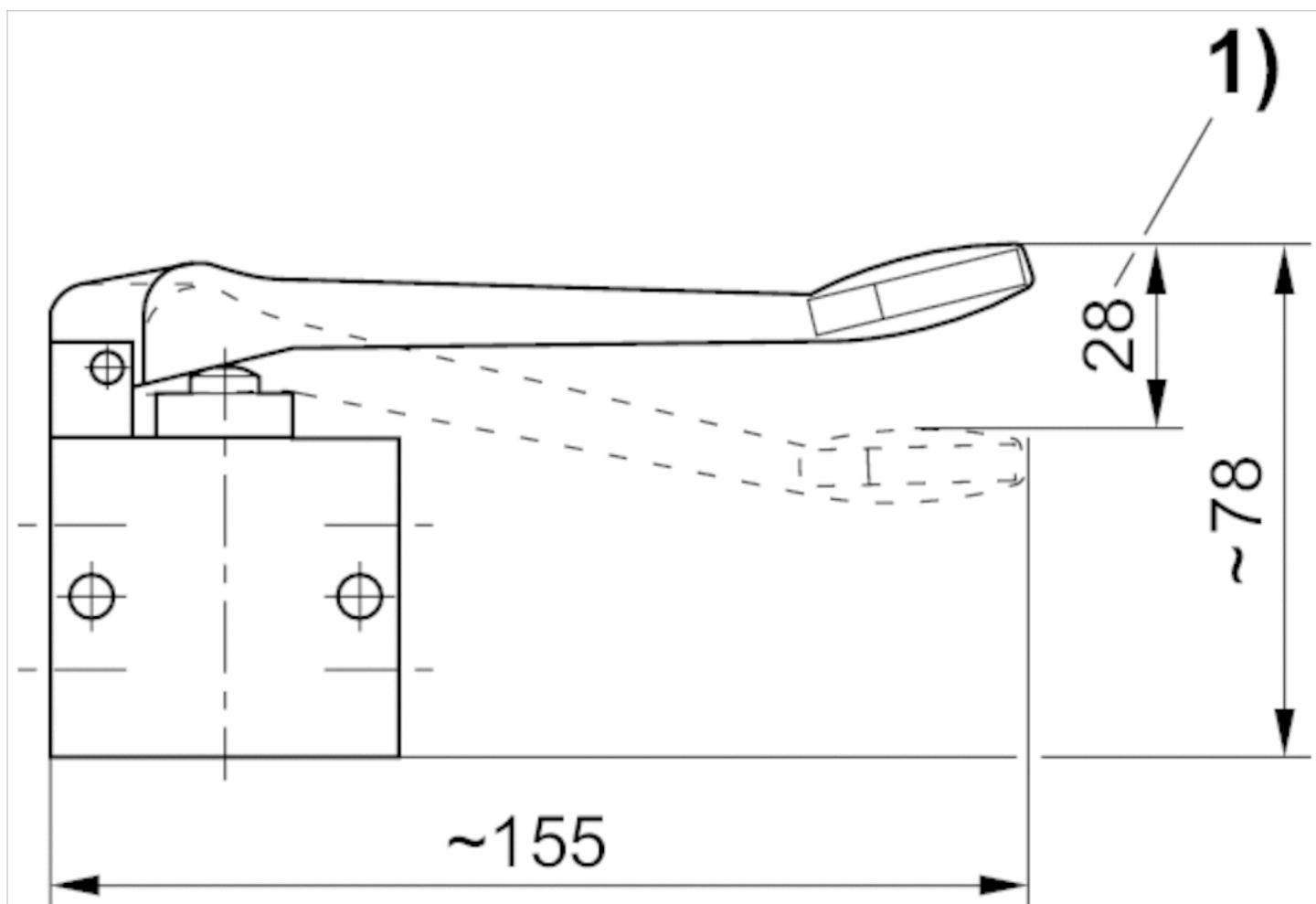

1) actuating stroke

Dimensions, Fig. 4

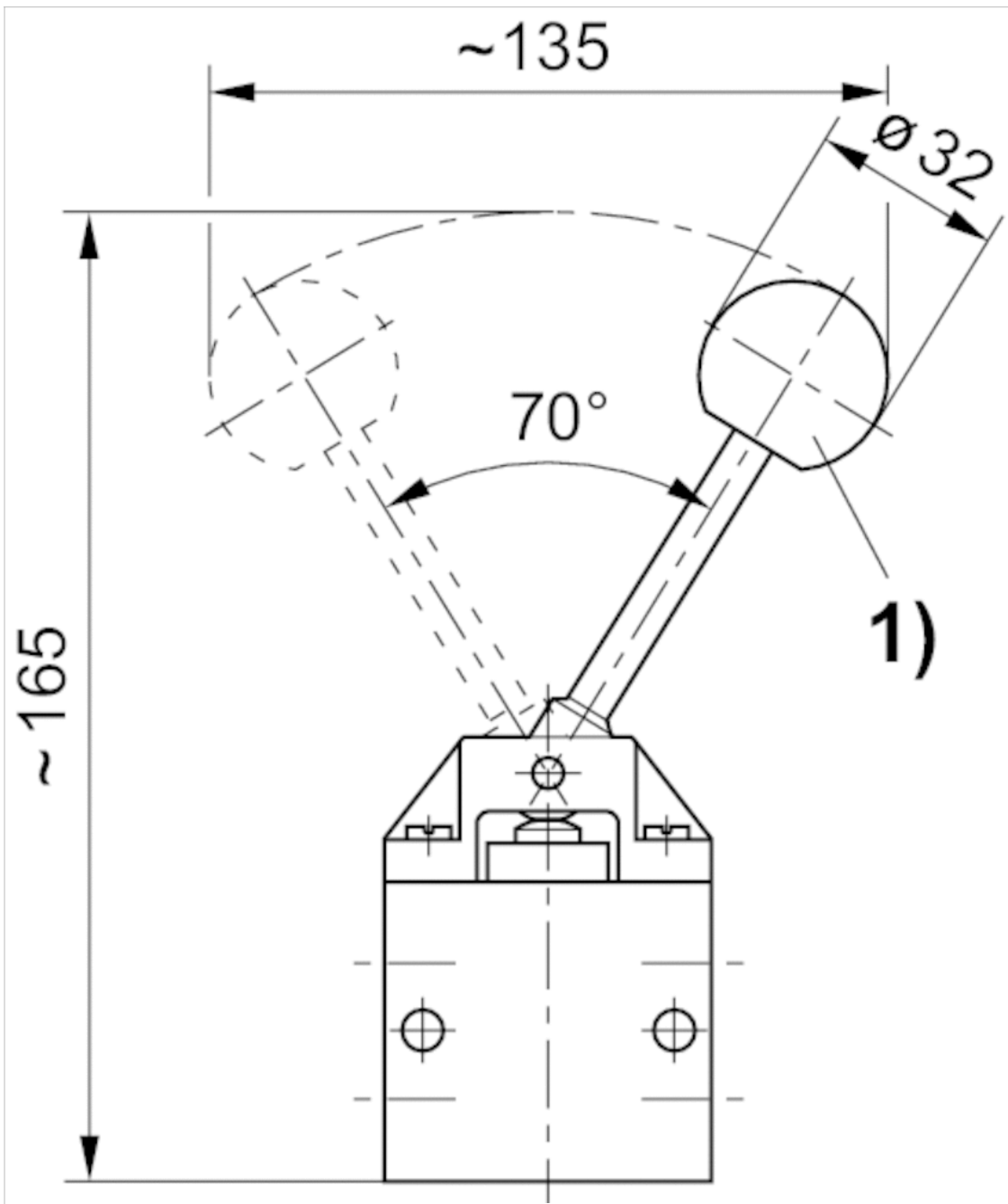

actuating torque: 40 Ncm

1) Ball

Dimensions, Fig. 5

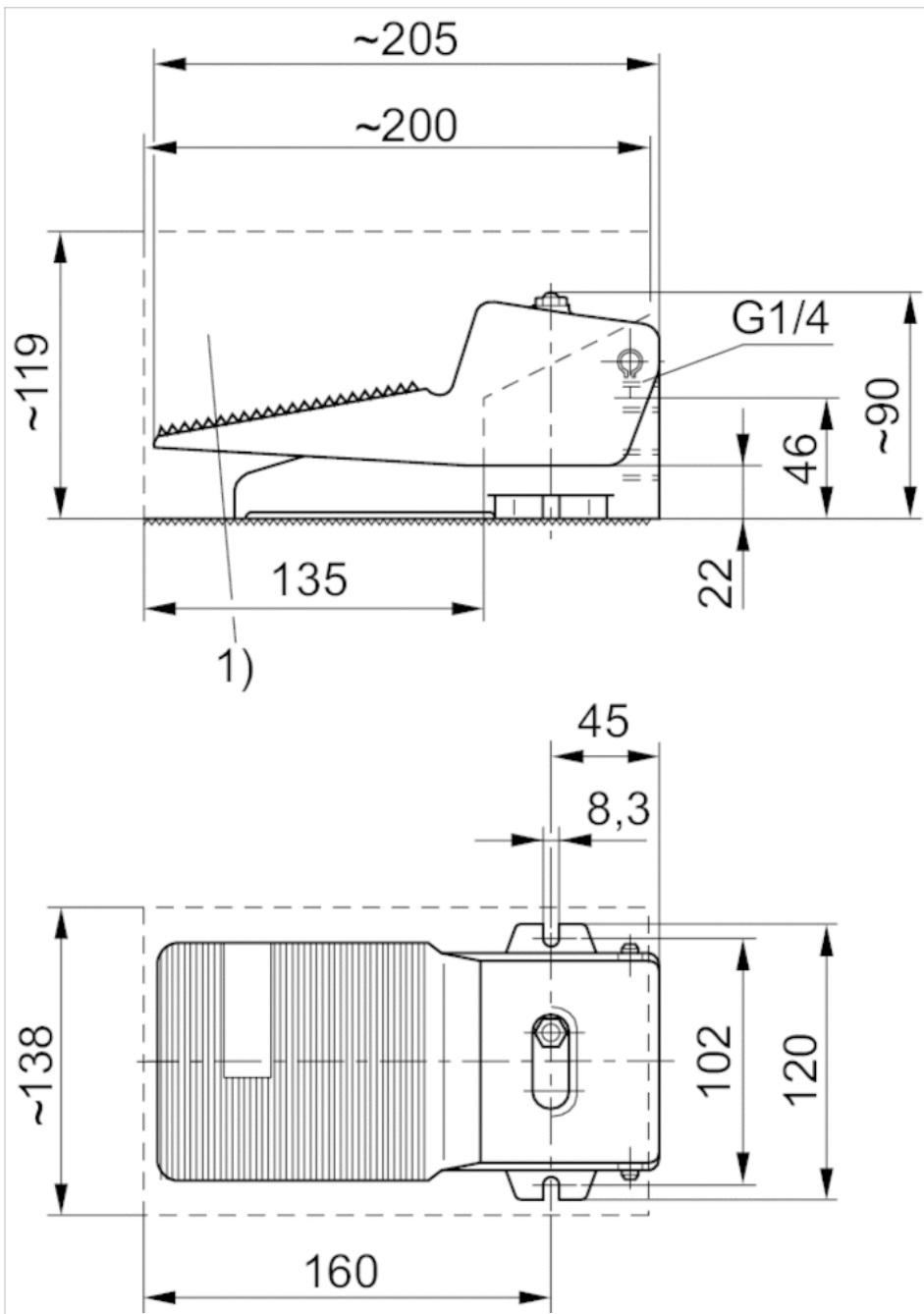

1) optional protective cover, part number 1828104001

Dimensions, Fig. 6

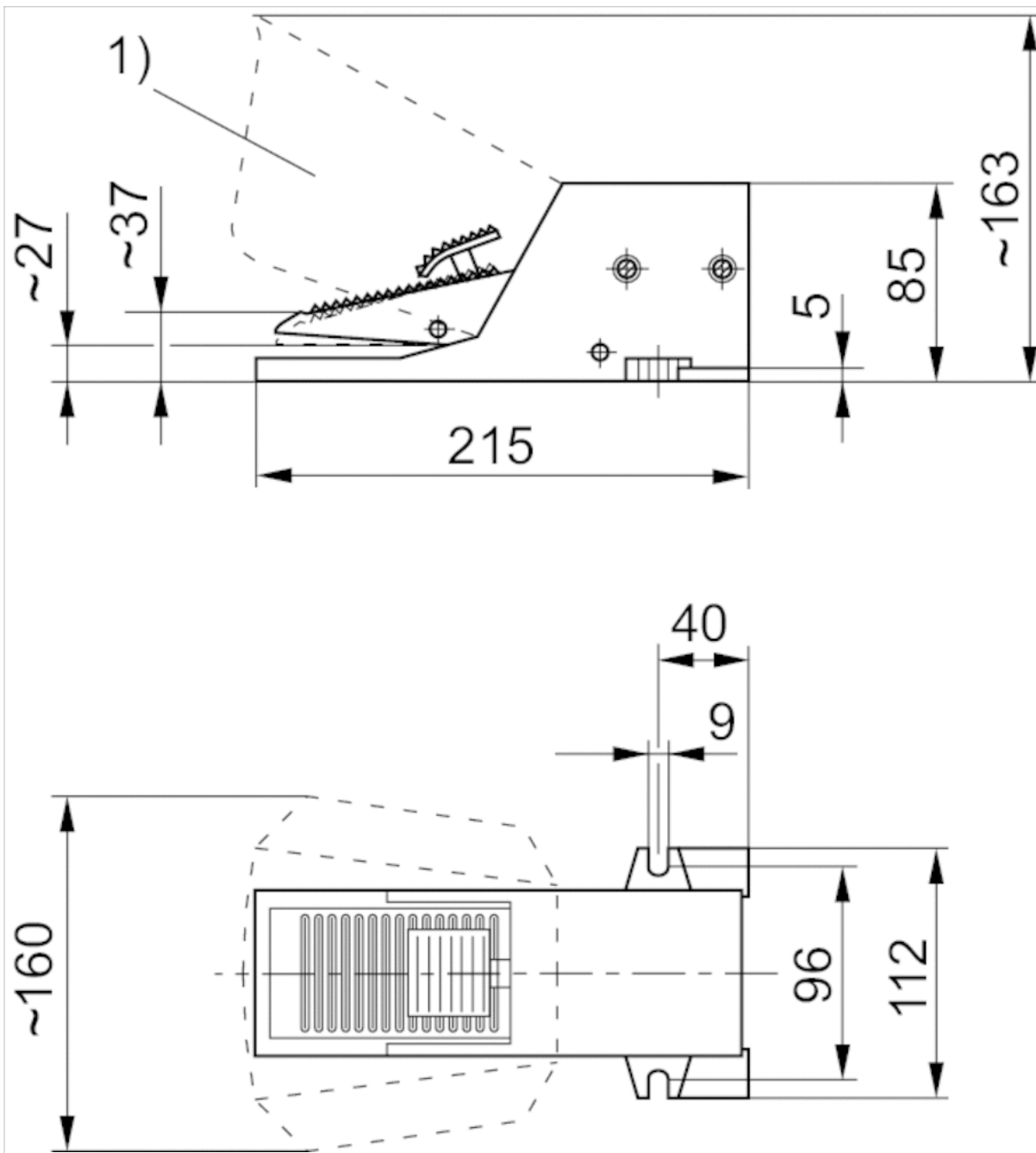

1) optional protective cover, part number 1828104002

Diagrams

Actuating force+

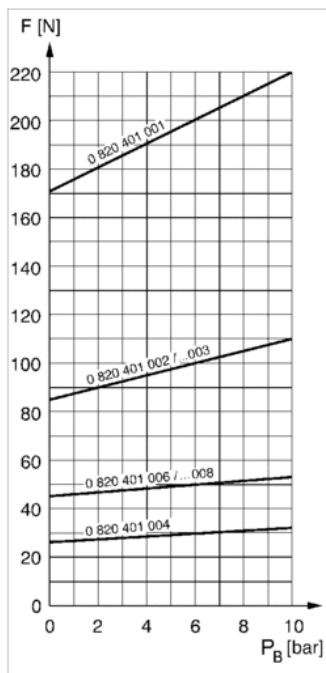

F = actuating force

P_B = Working pressure

Series AP - inch

- Qn 1►2 = 250 l/min
- Qn 2►3 = 150 l/min
- Compressed air connection output 1/8-27 NPTF
- Pipe connection



Version	Poppet valve
Activation	Mechanical
Actuating element	panel installation
Switching principle	3/2
Working pressure min./max.	0 ... 10 bar
Ambient temperature min./max.	-30 ... 80 °C
Medium temperature min./max.	-30 ... 80 °C
Medium	Compressed air
Max. particle size	5 µm
Oil content of compressed air	0 ... 5 mg/m ³
Weight	0.09 kg

An example configuration is illustrated.
The delivered product may thus deviate from the illustration.

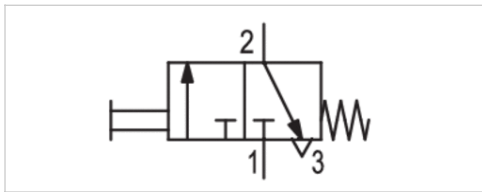

Technical data

Part No.	Compressed air connection type	Compressed air connection Input	Compressed air connection Output
R450055453	Internal thread	1/8 NPT	1/8-27 NPTF

Part No.	Compressed air connection Exhaust	Flow	
		Qn 1 ► 2	Qn 2 ► 3
R450055453	1/8 NPT	250 l/min	150 l/min

Nominal flow Qn at 6 bar and Δp = 1 bar

Please order control button separately., Cannot be combined with mushroom button with detent and rotary release R412012741

Technical information

Material	
Housing	Aluminum
Seals	Acrylonitrile butadiene rubber

Dimensions

Dimensions, cut-out in the front plate

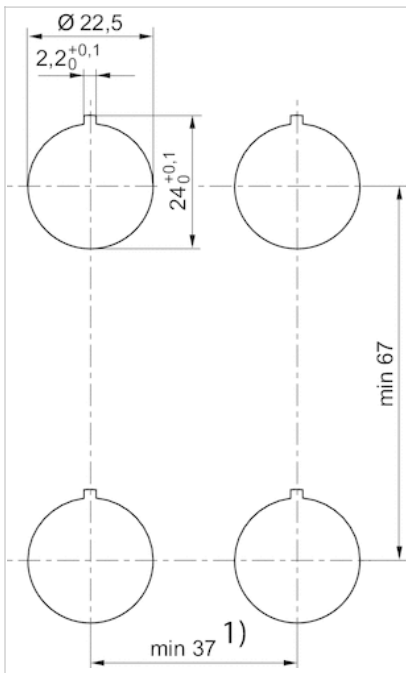

1) For the mushroom buttons (R412012738, R412012739, R412012740) a minimum distance 41 mm must be ensured.

Diagrams

Actuating force+

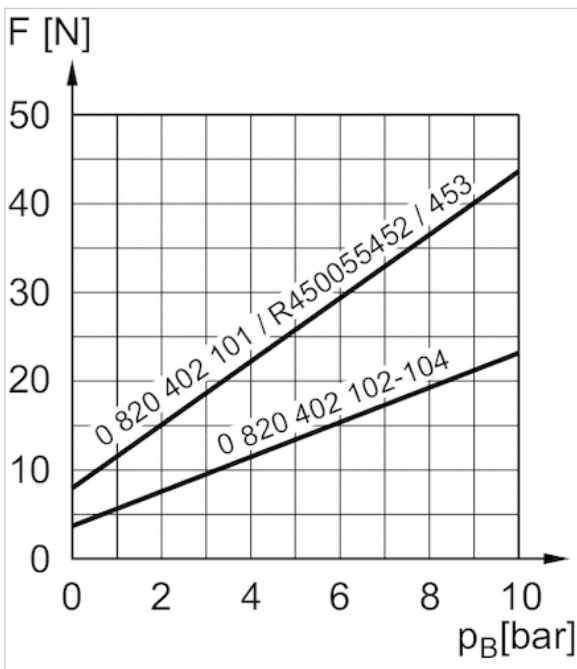

F = actuating force
 PB= Working pressure

Actuating controls for AP/ST series control panel valves

- for series AP, ST



Ambient temperature min./max.

-30 ... 70 °C

Weight

See table below

Technical data

Part No.	Type	Color	Scope of delivery
R412012734	Push button	Red	1 piece
R412012735	Push button	Black	1 piece
R412012736	Push button	Yellow	1 piece
R412012737	Push button	Green	1 piece
R412012738	Mushroom button	Red	1 piece
R412012739	Mushroom button	Green	1 piece
R412012740	Mushroom button	Yellow	1 piece
R412012741	Mushroom button with detent and rotary release	Red	1 piece
R412012742	Lever switch	Red	1 piece
R412012743	Lever switch	White	1 piece
R412012744	Rotary switch with two notched positions	Red	1 piece
R412012745	Rotary switch with two notched positions	Grey	1 piece
R412012748	Push button with detent and rotary release	Black	1 piece
R412012746	Rotary lock with two keys	Grey	1 piece
R412015479	Rotary lock with two keys	Grey	1 piece

Part No.	Weight	Fig.	
R412012734	0.011 kg	Fig. 1	-
R412012735	0.011 kg	Fig. 1	-
R412012736	0.011 kg	Fig. 1	-
R412012737	0.011 kg	Fig. 1	-
R412012738	0.024 kg	Fig. 2	-
R412012739	0.024 kg	Fig. 2	-
R412012740	0.024 kg	Fig. 2	-
R412012741	0.047 kg	Fig. 3	1)
R412012742	0.014 kg	Fig. 4	-
R412012743	0.014 kg	Fig. 4	-

R412012744	0.02 kg	Fig. 5	-
R412012748	0.032 kg	Fig. 6	-
R412015479	0.05 kg	Fig. 7	3)

- 1) Only for ST series spring-return valves (R422002211, R422002213)
- 2) The key can be removed only if the button is in the actuated state.
- 3) The key can be removed in the actuated or non-actuated state.

Technical information

Combining an ST control panel valve with an actuating control may create an emergency OFF control device, which must comply with the applicable regulations in the EC Machinery Directive 2006/42/EC and the EN ISO 13850 and EN ISO 13849 standards. In terms of EN ISO 13849, an ST control panel valve is a single-channel component. A sturdier architecture must be selected to attain a higher performance level (c, d, e).

Technical information

Housing	Polyamide
---------	-----------

Dimensions

Dimensions, cut-out in the front plate, single valve

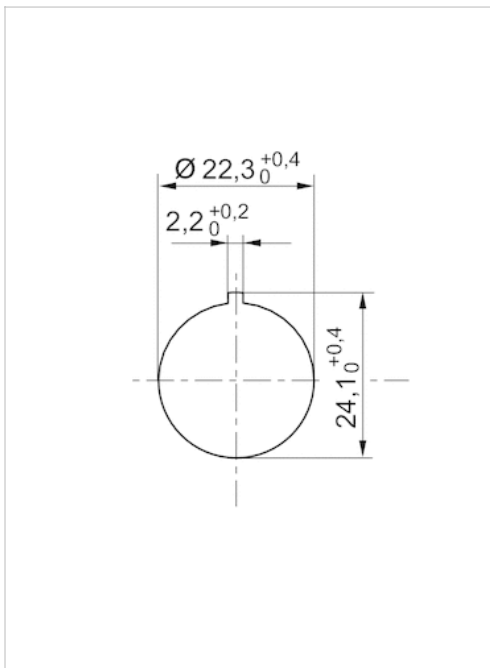

When arranging multiple valves, see “cut-out in the front plate” of the AP or ST series.

Fig. 1

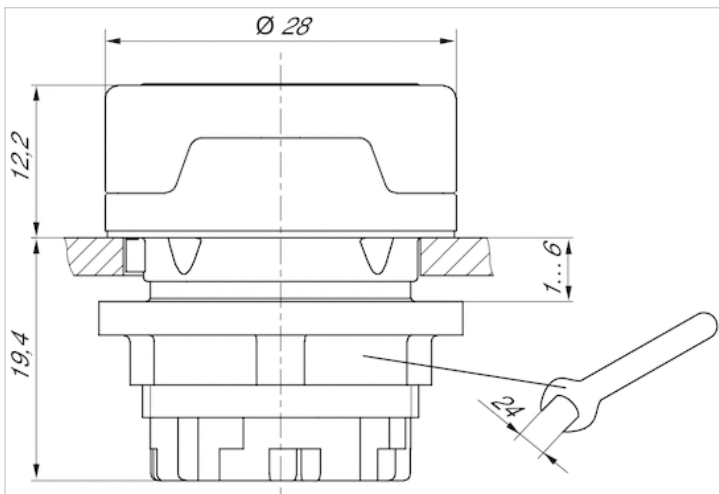

Fig. 2

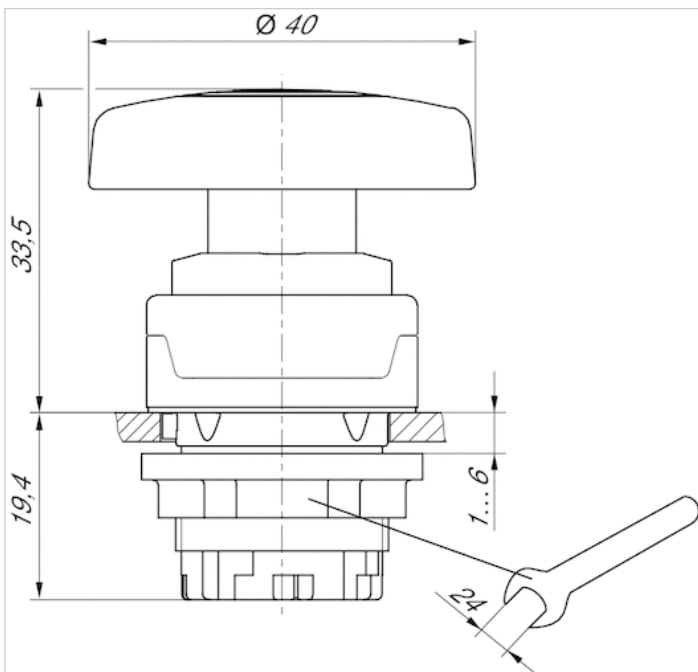
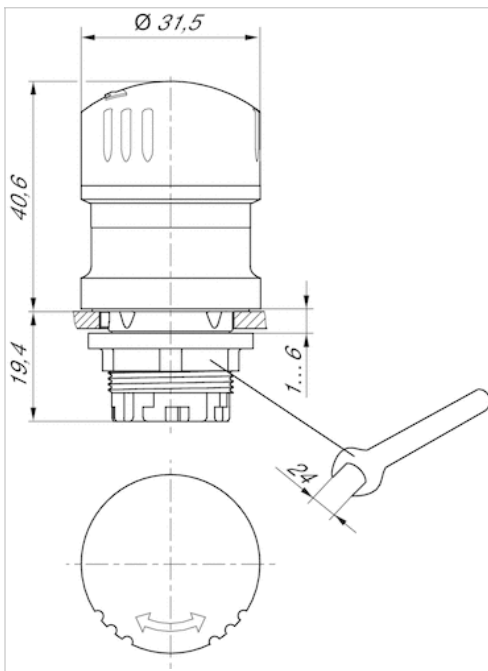

Fig. 3



Only for ST series spring-return valves (R422002211, R422002213)

Fig. 4

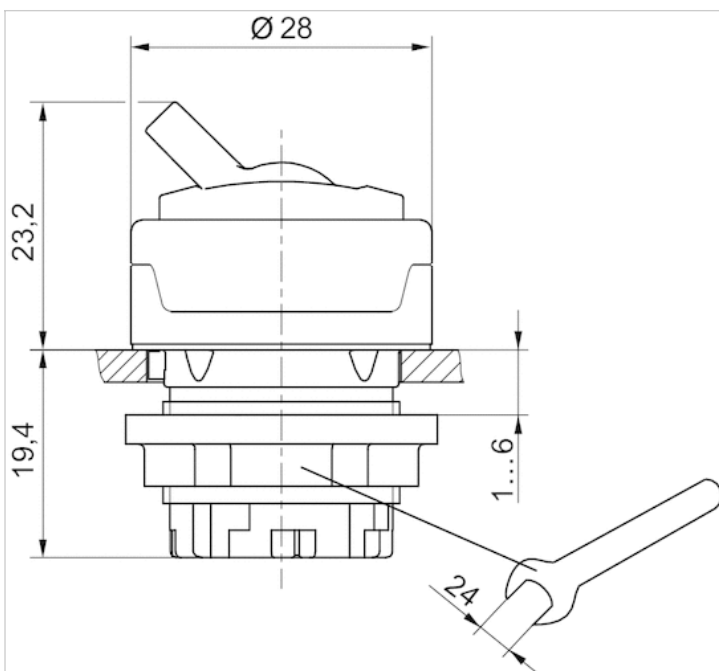

Fig. 5

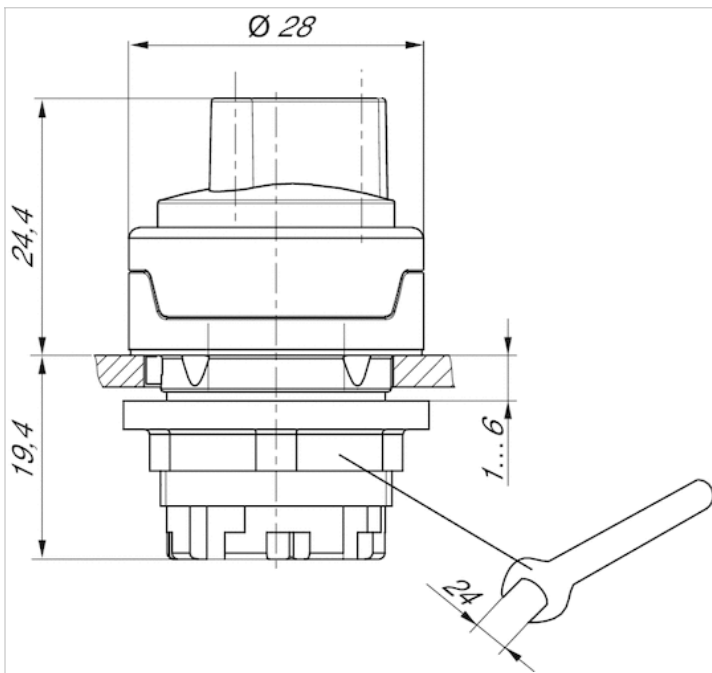

Fig. 6

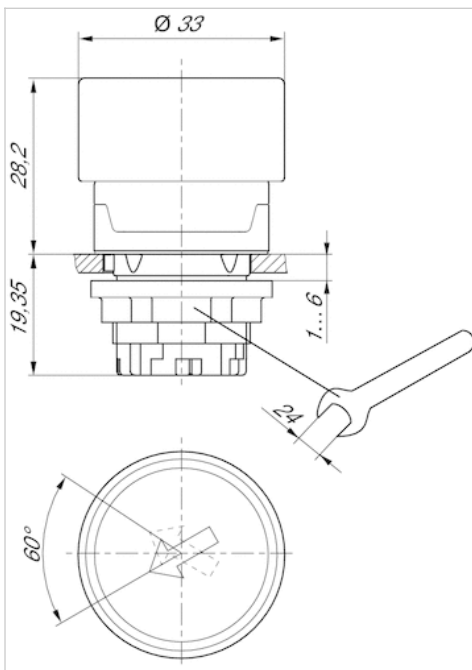
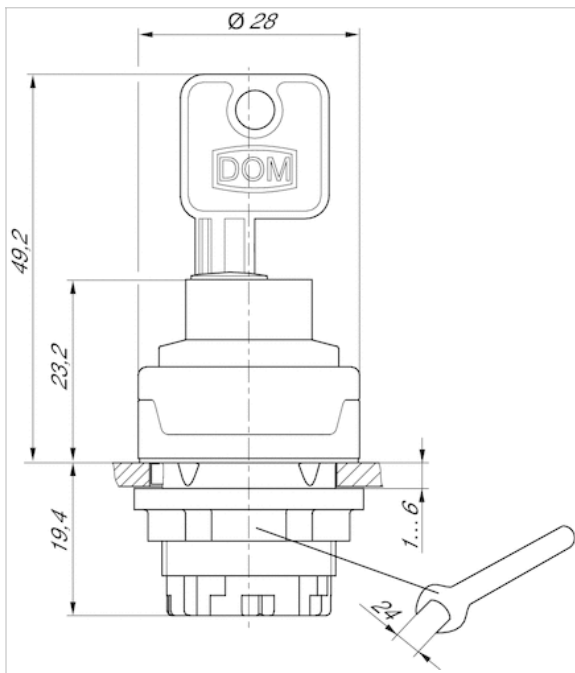
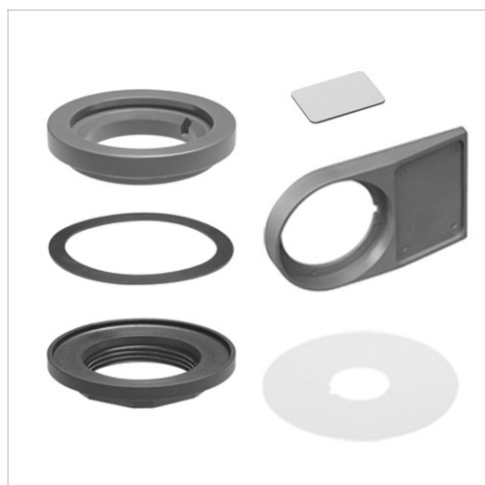

Fig. 7



Accessories for actuating controls for AP/ST series control panel valves

- for series AP, ST



Ambient temperature min./max.

-30 ... 70 °C

Weight

See table below

Technical data

Part No.	Type	Color	Material	Weight	Fig.	
R412012749	Label base	Anthracite	Polyamide	0.003 kg	Fig. 1	-
R412012750	Name plates, angular	silver	Polyvinyl chloride	0.001 kg	Fig. 2	-
R412012751	Emergency OFF sign, round	Yellow	Polyvinyl chloride	0.001 kg	Fig. 3	1)
R412012752	Blanking plug	Anthracite	Polyamide	0.026 kg	Fig. 4	-
R412012753	Mounting nut M22x1	Black	Polyamide	0.007 kg	Fig. 5	-
R412012989	Spare key	-	-	0.001 kg	Fig. 6	-
R412015512	Reduction , Ø30.5 to Ø22.5	-	Polyamide	0.001 kg	Fig. 7	-

1) Only for ST series spring-return valves (R422002211, R422002213)

Technical information

Material	
Housing	Polyamide Polyvinyl chloride

Dimensions

Fig. 7

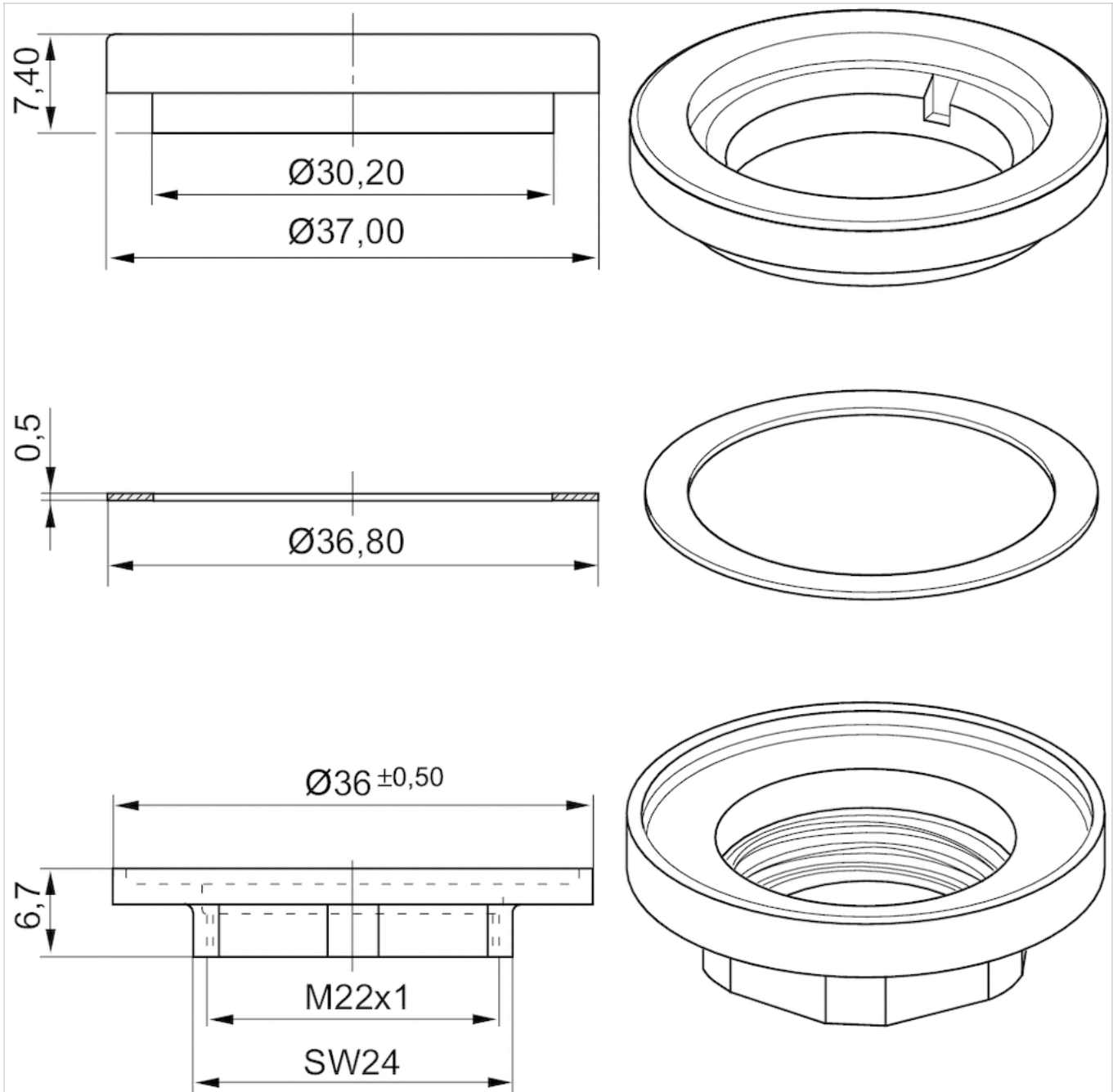

Fig. 1

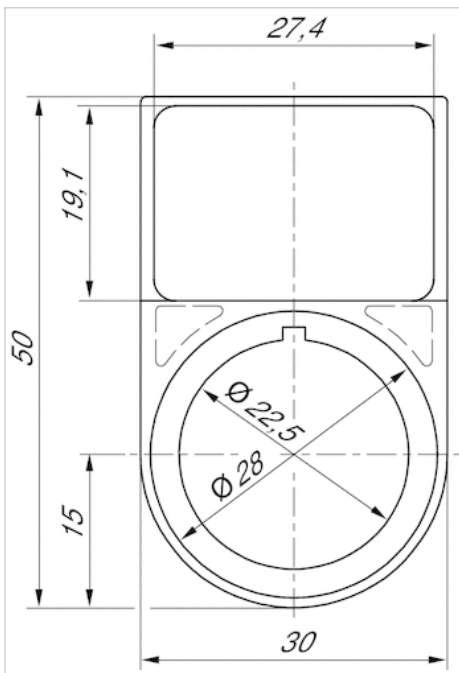

Fig. 2

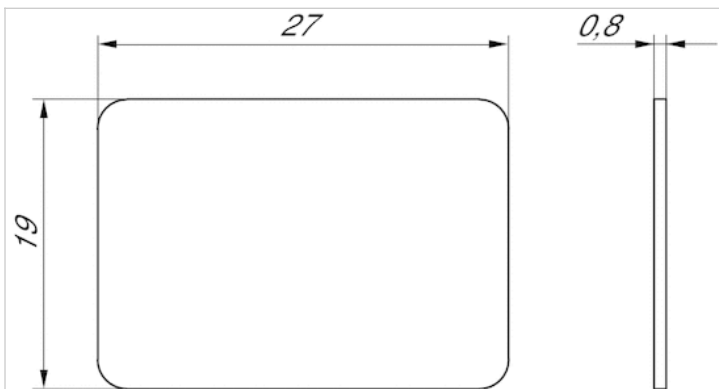
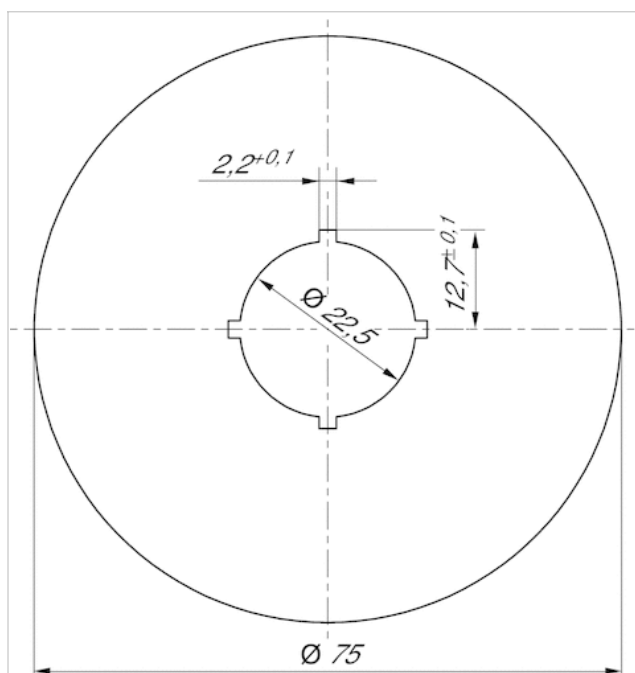

Fig. 3



Only for ST series spring-return valves (R422002211, R422002213)

Fig. 4

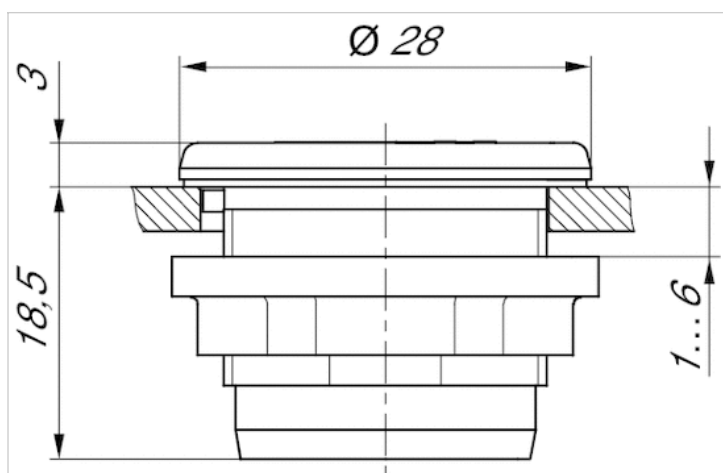

Fig. 5

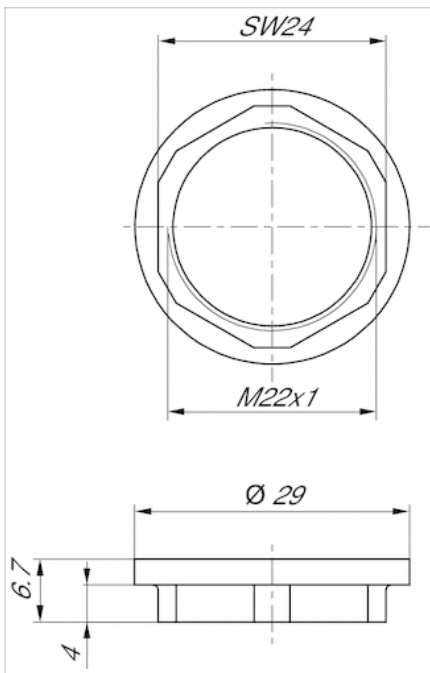
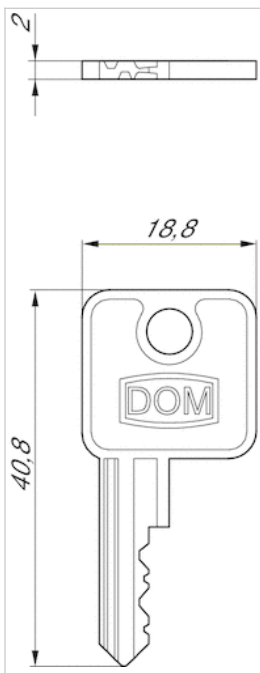
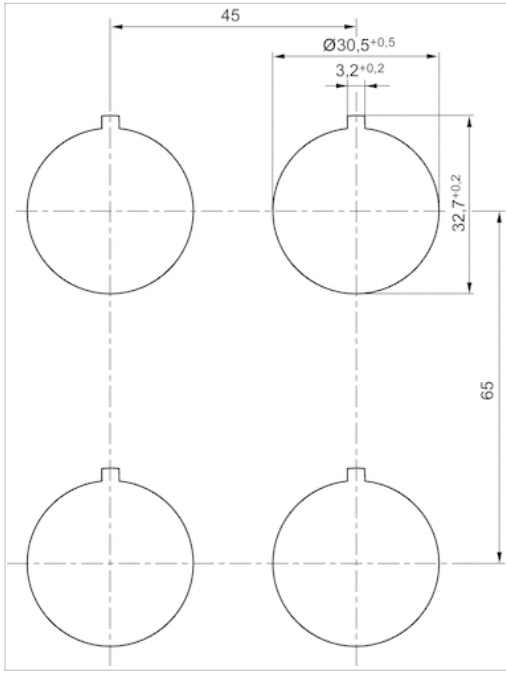

Fig. 6





Adapter kit to connect actuating controls to AP/ST series valves

- for series AP, ST



Ambient temperature min./max.

-30 ... 70 °C

Weight

0.003 kg

Technical data

Part No.	Type
R422002219	Adapter

Technical information

The adapter kit is only needed to connect the following actuating controls

R412012734, R412012735, R412012736, R412012737, R412012738, R412012739, R412012740,

R412012741, R412012742, R412012743, R412012744, R412012745, R412012746, R412012748

to the following valves 0820402024, 0820402025, 0820403024, 0820403025, 0820402106, 0820408007, 0820404025.

Technical information

Material	
Housing	Polyamide

Dimensions

Dimensions

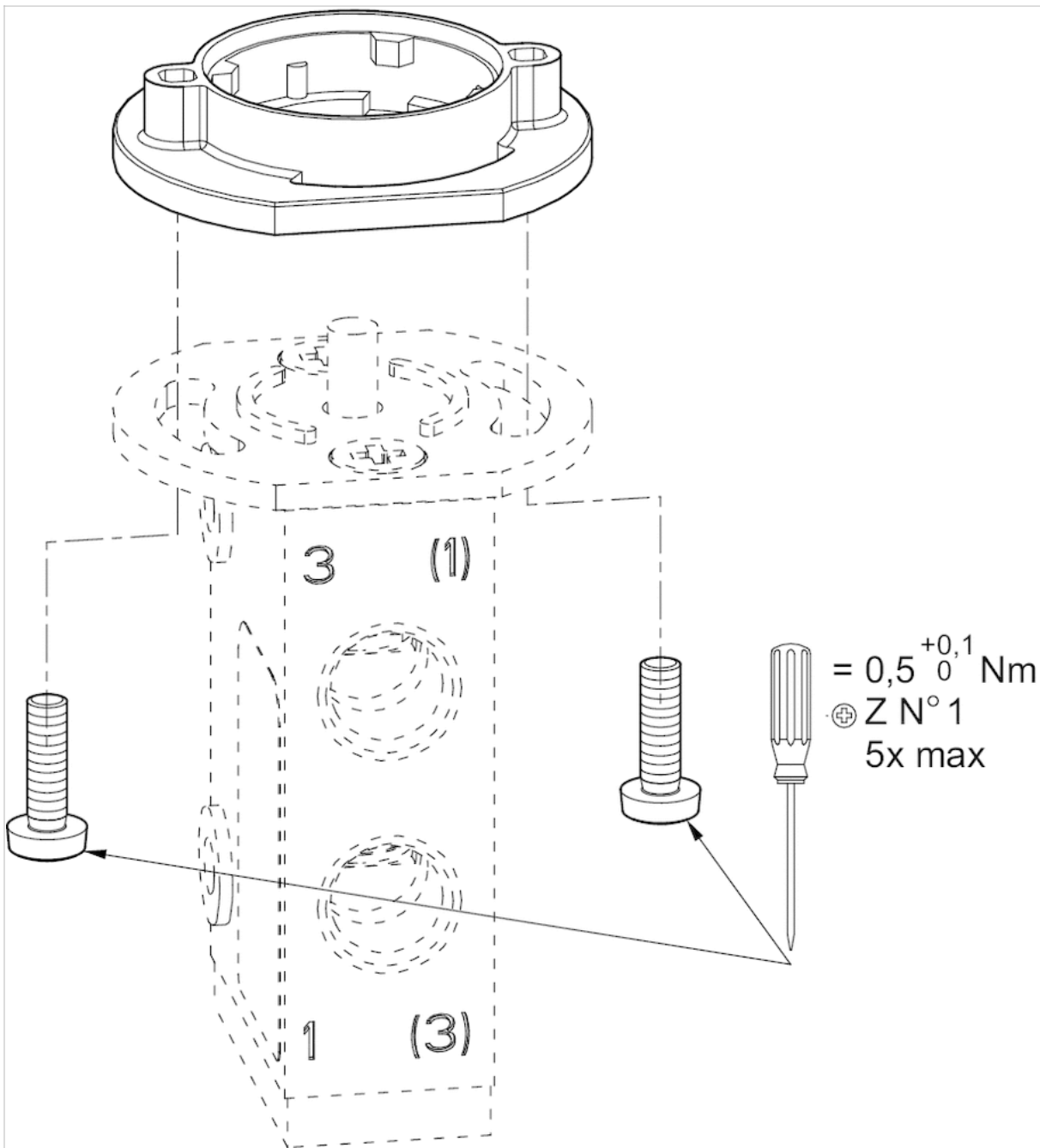

for panel-mounted valves

Protective cover, Series AP



Weight

1 kg

Technical data

Part No.	Type	Suitable for
1828104001	Protective cover for valve foot pedal	Valve foot pedal

Delivery incl. seal and mounting screw

Technical information

Material	
Housing	Steel, painted gray

Dimensions

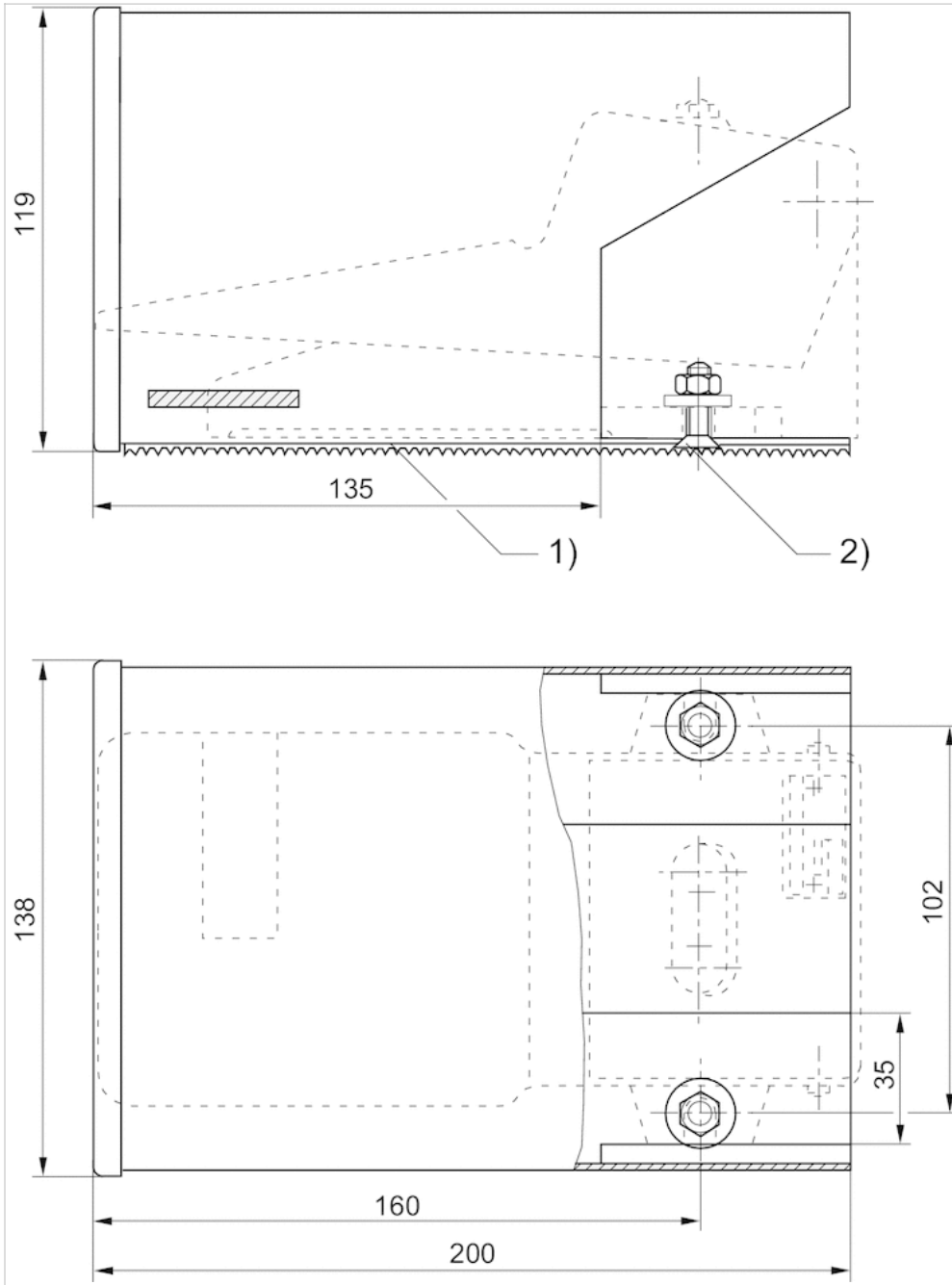

1) Ribbed rubber 2) Countersunk screw with hexagon socket M6 x20

Protective cover, Series AP



Weight

0.35 kg

Technical data

Part No.	Type
1828104002	Protective cover for valve foot pedal, with detent

Part No.	Suitable for
1828104002	Valve foot pedal, with detent

Delivery incl. 2 mounting screws

Technical information

Material	
Housing	Aluminum, painted gray

Dimensions

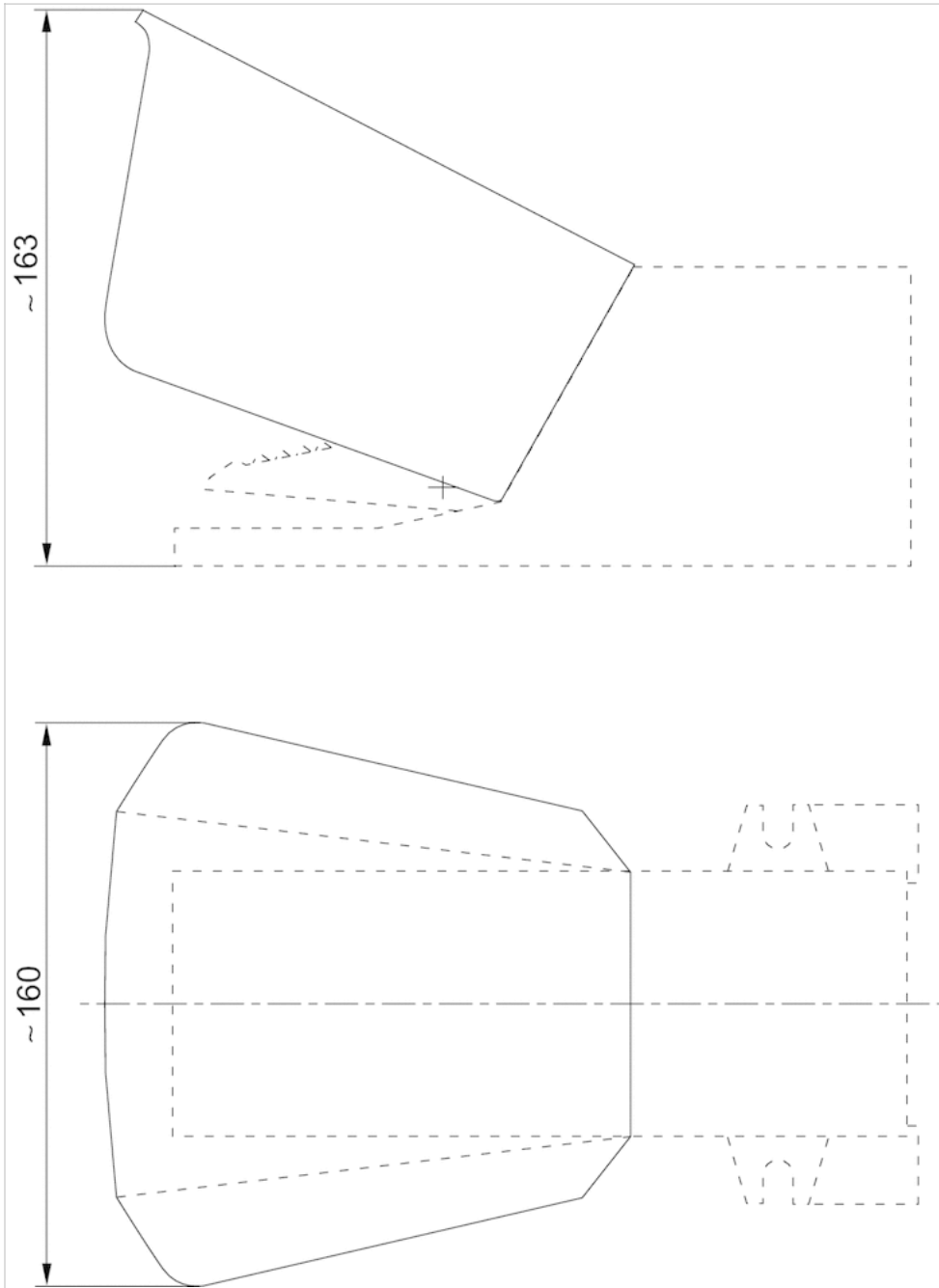

Silencers, series SI1

- G 1/8 G 1/4
- Sintered bronze



Working pressure min./max.	0 ... 10 bar
Ambient temperature min./max.	-25 ... 80 °C
Medium	Compressed air
Sound pressure level	See table below
Weight	See table below
Comment	Flow characteristic curves can be found under "Diagrams".

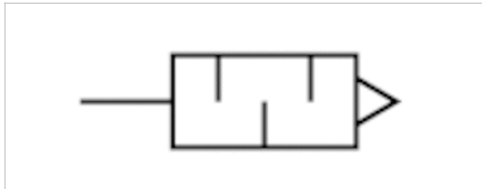

Technical data

Part No.	Compressed air connection	Sound pressure level	Flow	Delivery unit	Weight
			Qn		
1827000000	G 1/8	75 dB	1623 l/min	10 piece	0.01 kg
1827000001	G 1/4	79 dB	3390 l/min	10 piece	0.02 kg

Weight per piece

Nominal flow Qn at p1 = 6 bar (absolute) freely discharged. Sound pressure level measured at 6 bar against atmosphere at 1 m distance.

Technical information

Material	
Silencer	Sintered bronze
Thread	Brass

Dimensions

Dimensions in mm

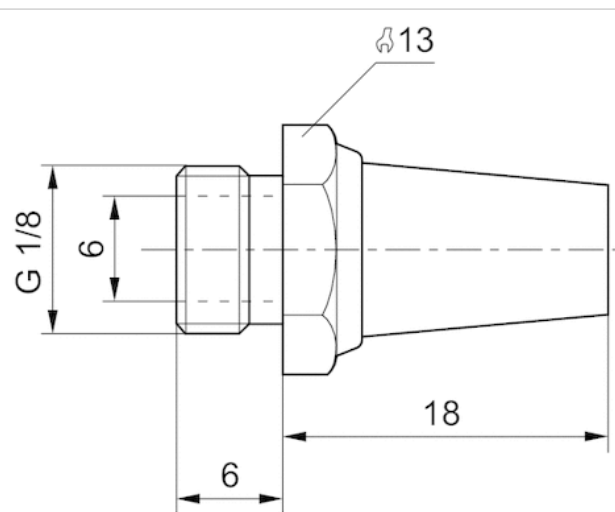

Dimensions in mm

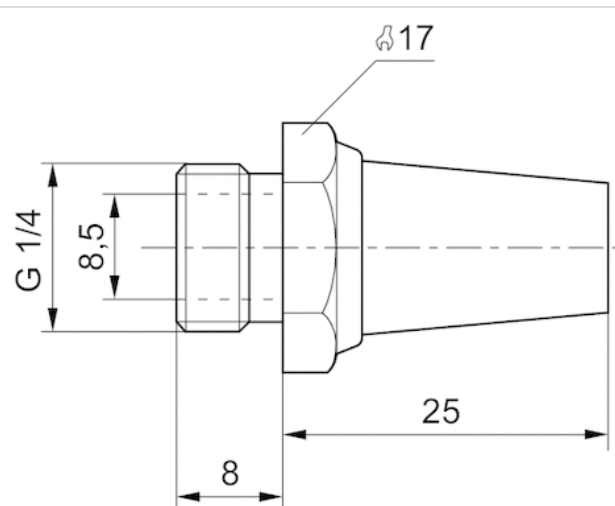

Diagrams

Flow diagram, 1827000006

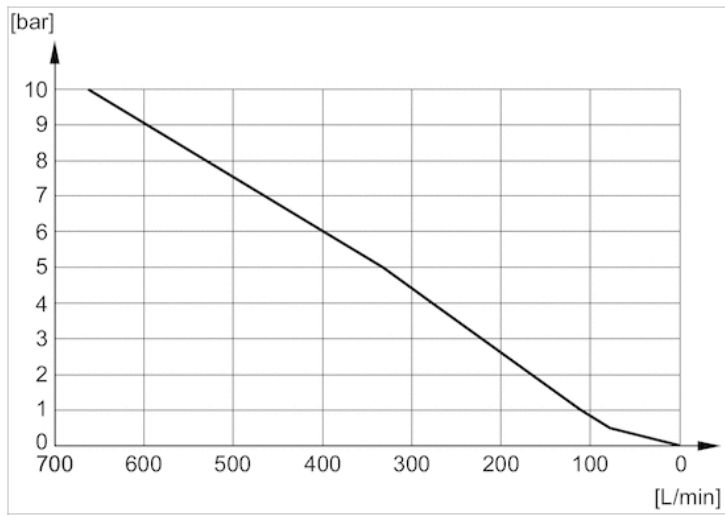

Efficient pneumatic solutions, our program: cylinders and drives, valves and valve systems, air supply management



Visit us: [Emerson.com/Aventics](https://www.emerson.com/aventics)

Your local contact: [Emerson.com/contactus](https://www.emerson.com/contactus)



Emerson.com



[Facebook.com/EmersonAutomationSolutions](https://www.facebook.com/EmersonAutomationSolutions)



[LinkedIn.com/company/Emerson-Automation-Solutions](https://www.linkedin.com/company/Emerson-Automation-Solutions)



[Twitter.com/EMR_Automation](https://twitter.com/EMR_Automation)

An example configuration is depicted on the title page. The delivered product may thus vary from that in the illustration. Subject to change. This Document, as well as the data, specifications and other information set forth in it, are the exclusive property of AVENTICS GmbH. It may not be reproduced or given to third parties without its consent. Only use the AVENTICS products shown in industrial applications. Read the product documentation completely and carefully before using the product. Observe the applicable regulations and laws of the respective country. When integrating the product into applications, note the system manufacturer's specifications for safe use of the product. The data specified only serve to describe the product. No statements concerning a certain condition or suitability for a certain application can be derived from our information. The information given does not release the user from the obligation of own judgment and verification. It must be remembered that the products are subject to a natural process of wear and aging.

The Emerson logo is a trademark and service mark of Emerson Electric Co. Brand logotype are registered trademarks of one of the Emerson family of companies. All other marks are the property of their respective owners. © 2017 Emerson Electric Co. All rights reserved.
2019-03



CONSIDER IT SOLVED™