

Series CD01-PA

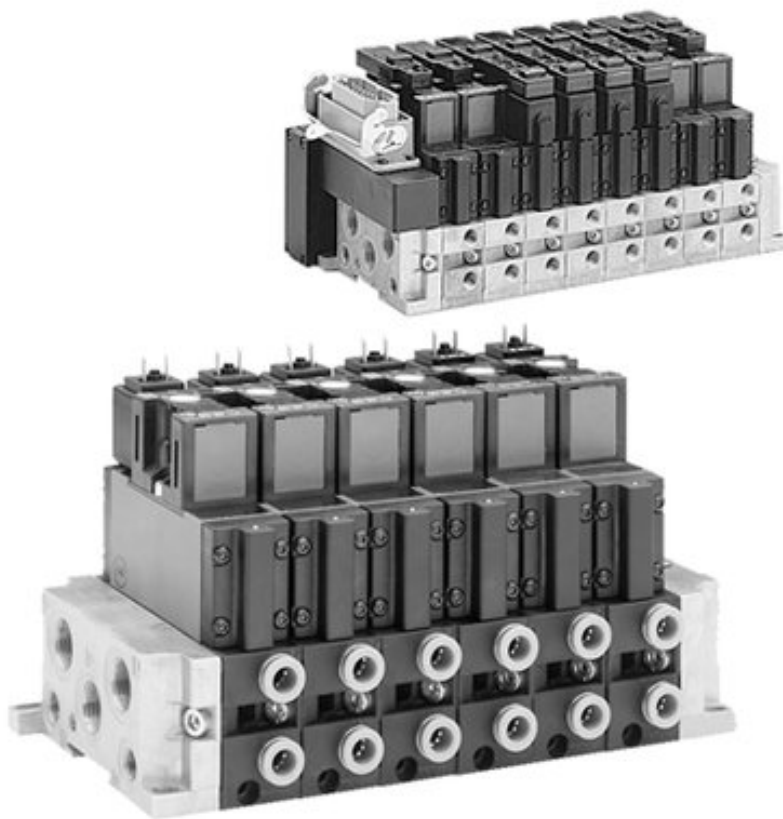

AVENTICS™ Series CD01-PA



Valve system, Series CD01-PA

- Configurable valve systems



Standards	ISO 15407-1
Working pressure min./max.	-0.9 ... 16 bar
Control pressure min./max.	2 ... 16 bar
Ambient temperature min./max.	-15 ... 50 °C
Medium temperature min./max.	-15 ... 50 °C
Medium	Compressed air
Max. particle size	50 µm
Oil content of compressed air	0 ... 5 mg/m ³
Nominal flow Qn	1010 l/min
Operational voltage electronics	24 V DC
Number of valve positions max.	12
Protection class with connection	IP65
DC operating voltage	24 V
Voltage tolerance DC	-10% / +10%

An example configuration is illustrated. The delivered product may thus deviate from the illustration.

Overview of variants

	Version	You have the following options:
	Single plug-in wiring	Electrical connection plug, M12 plug, form C ATEX optional
	Single plug-in wiring	Electrical connection contact bridge, individual exit and cable duct ATEX optional
	Multipole	Electrical connection HAN multipole plug, 25-pin, top
	Multipole	Electrical connection D-Sub plug, 37-pin, top

Technical information

The min. control pressure must be adhered to, since otherwise faulty switching and valve failure may result!
 The pressure dew point must be at least 15 °C under ambient and medium temperature and may not exceed 3 °C .
 The oil content of compressed air must remain constant during the life cycle.
 Use only the approved oils from AVENTICS. Further information can be found in the "Technical information" document (available in the MediaCentre).

See the following pages on the series for technical data on individual components.
 Working pressure and control pressure depend on the valve configuration.

Dimensions

Dimensions, Flat pins

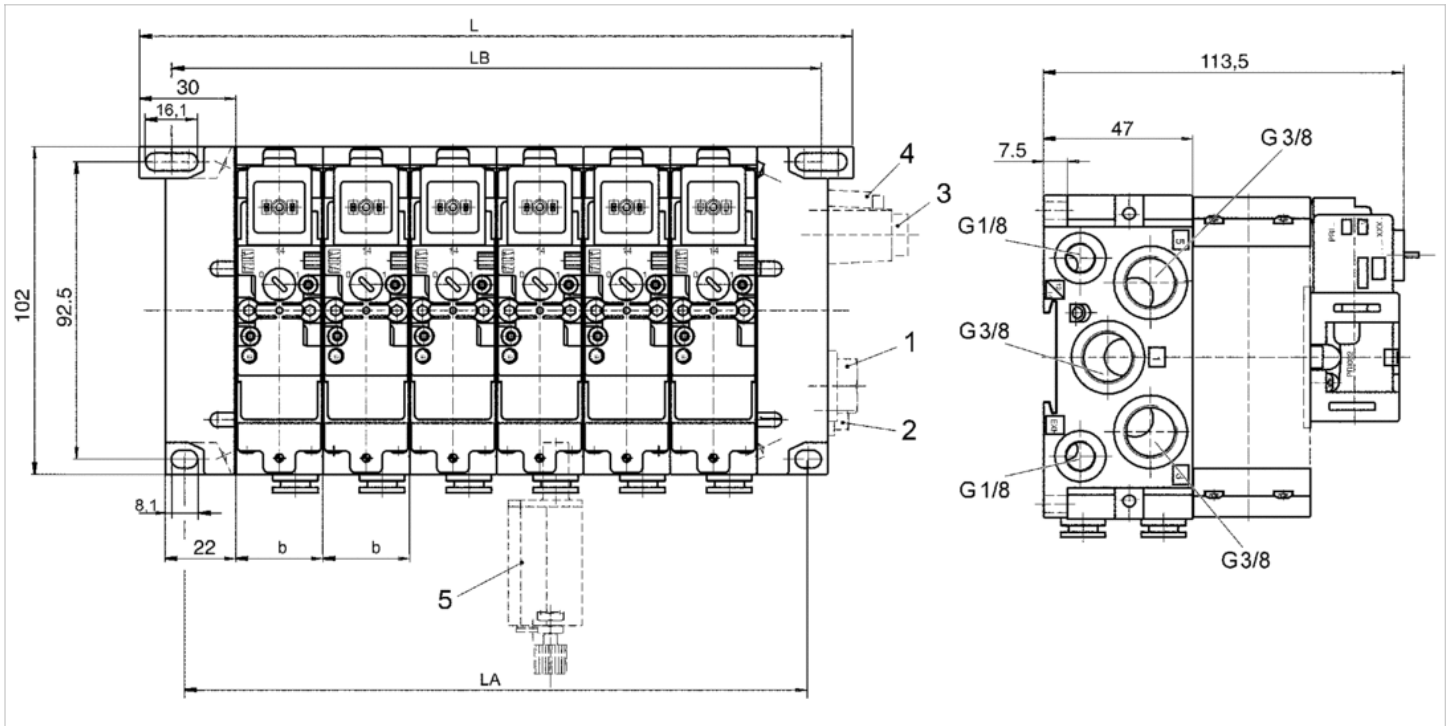

1) blanking screw G 3/8 2) blanking screw G 1/8 3) silencer G 3/8 4) silencer G 1/8 5) check-choke valve

$$L = n \cdot b + 94$$

$$LB = n \cdot b + 40$$

$$LA = n \cdot b + 32$$

n = number of valve positions

b = width of valve positions (27.0 ... 27.25 mm)

An example configuration is illustrated. The delivered product may thus deviate from the illustration.

Dimensions, M12 plug

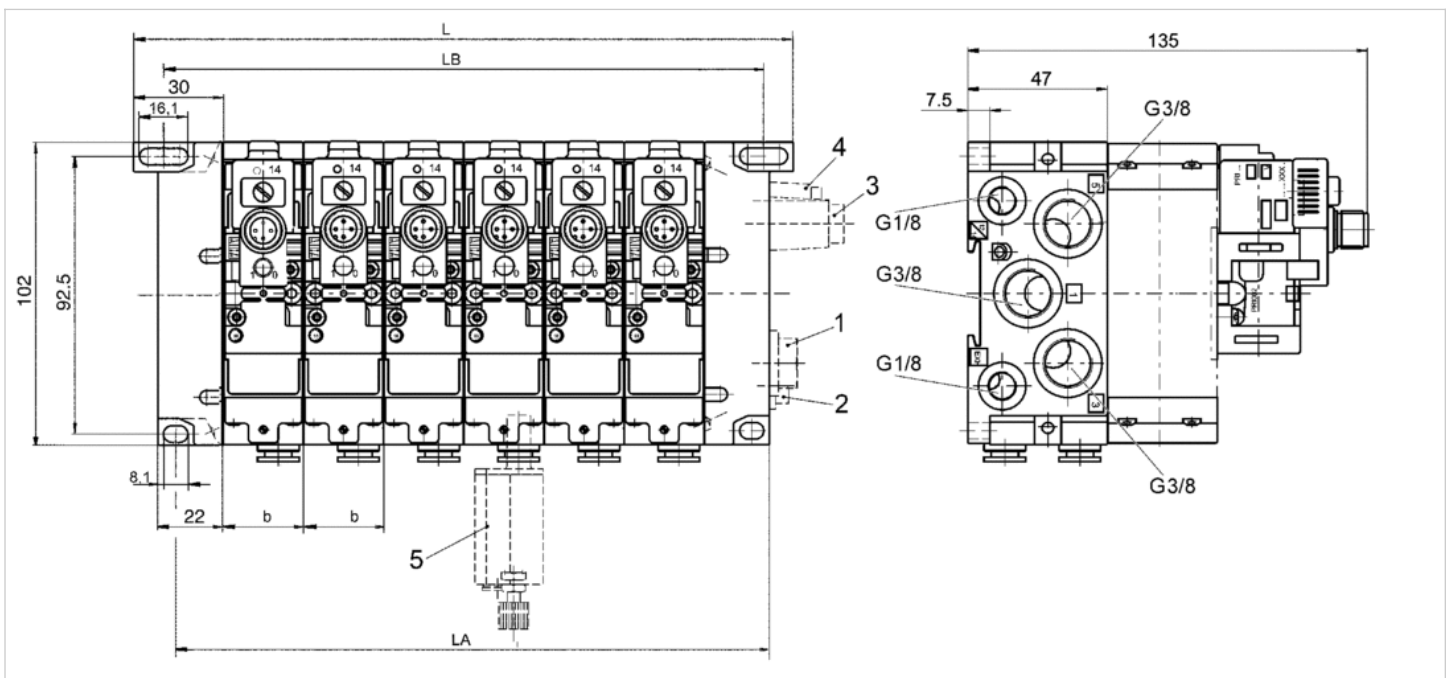

1) blanking screw G 3/8 2) blanking screw G 1/8 3) silencer G 3/8 4) silencer G 1/8 5) check-choke valve

$$L = n * b + 94$$

$$LB = n * b + 40$$

$$LA = n * b + 32$$

n = number of valve positions

b = width of valve positions (27.0 ... 27.25 mm)

An example configuration is illustrated. The delivered product may thus deviate from the illustration.

Dimensions, contact bridge, individual exit and cable duct

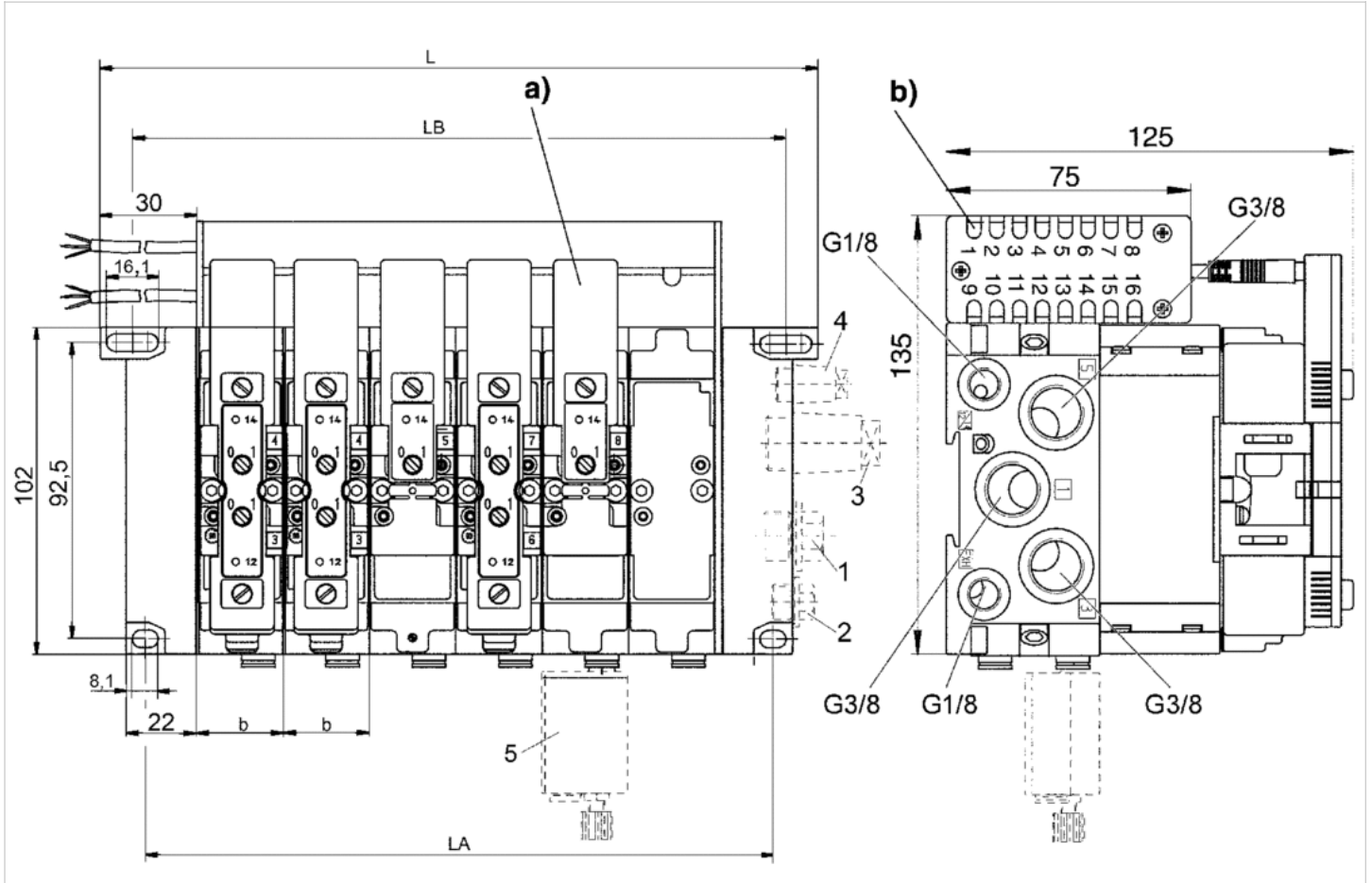

1) blanking screw G 3/8 2) blanking screw G 1/8 3) silencer G 3/8 4) silencer G 1/8 5) check-choke valve

a) electrical bridge b) cable outlet on left or right side

$$L = n * b + 94$$

$$LB = n * b + 40$$

$$LA = n * b + 32$$

n = number of valve positions

b = width of valve positions (27.0 ... 27.25 mm)

An example configuration is illustrated. The delivered product may thus deviate from the illustration.

Dimensions, Fieldbus connection with valve system (VDS)

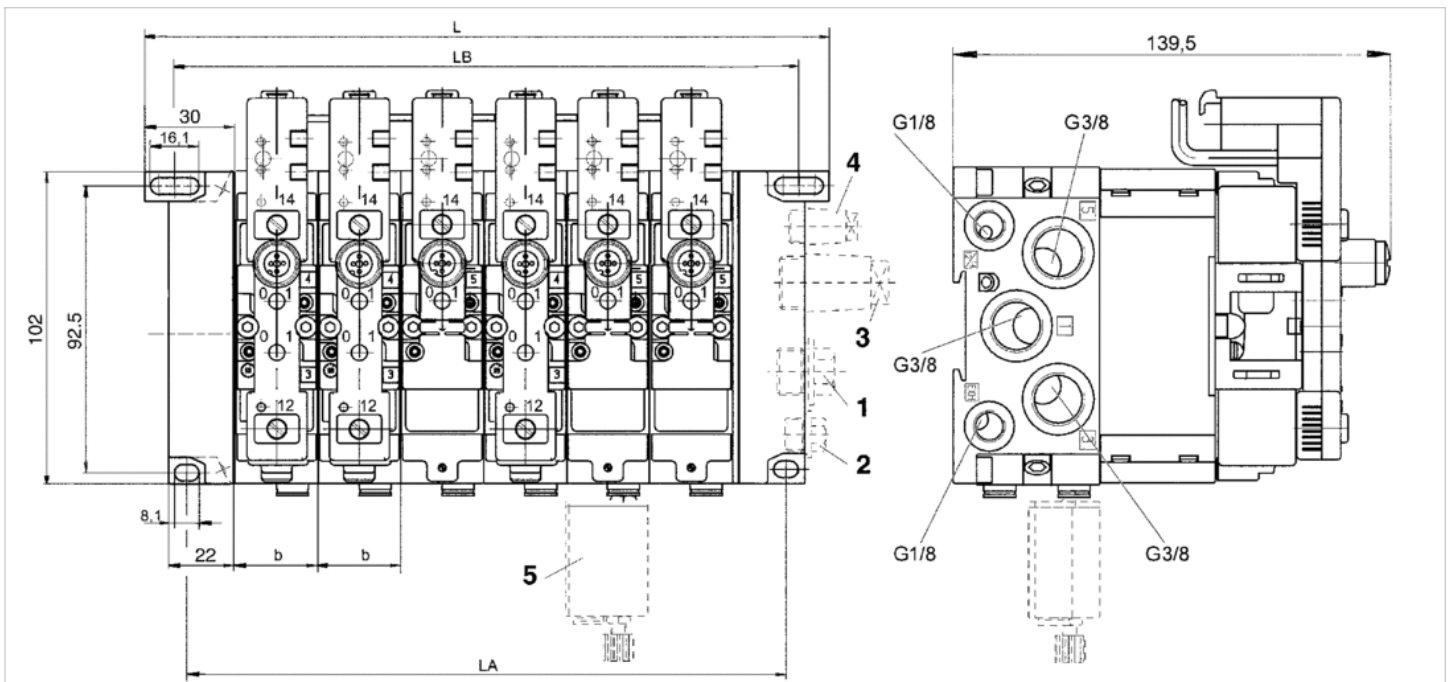

1) blanking screw G 3/8 2) blanking screw G 1/8 3) silencer G 3/8 4) silencer G 1/8 5) check-choke valve

$$L = n * b + 94$$

$$LB = n * b + 40$$

$$LA = n * b + 32$$

n = number of valve positions

b = width of valve positions (27.0 ... 27.25 mm)

An example configuration is illustrated. The delivered product may thus deviate from the illustration.

Dimensions, HAN multipole plug, 25-pin, top

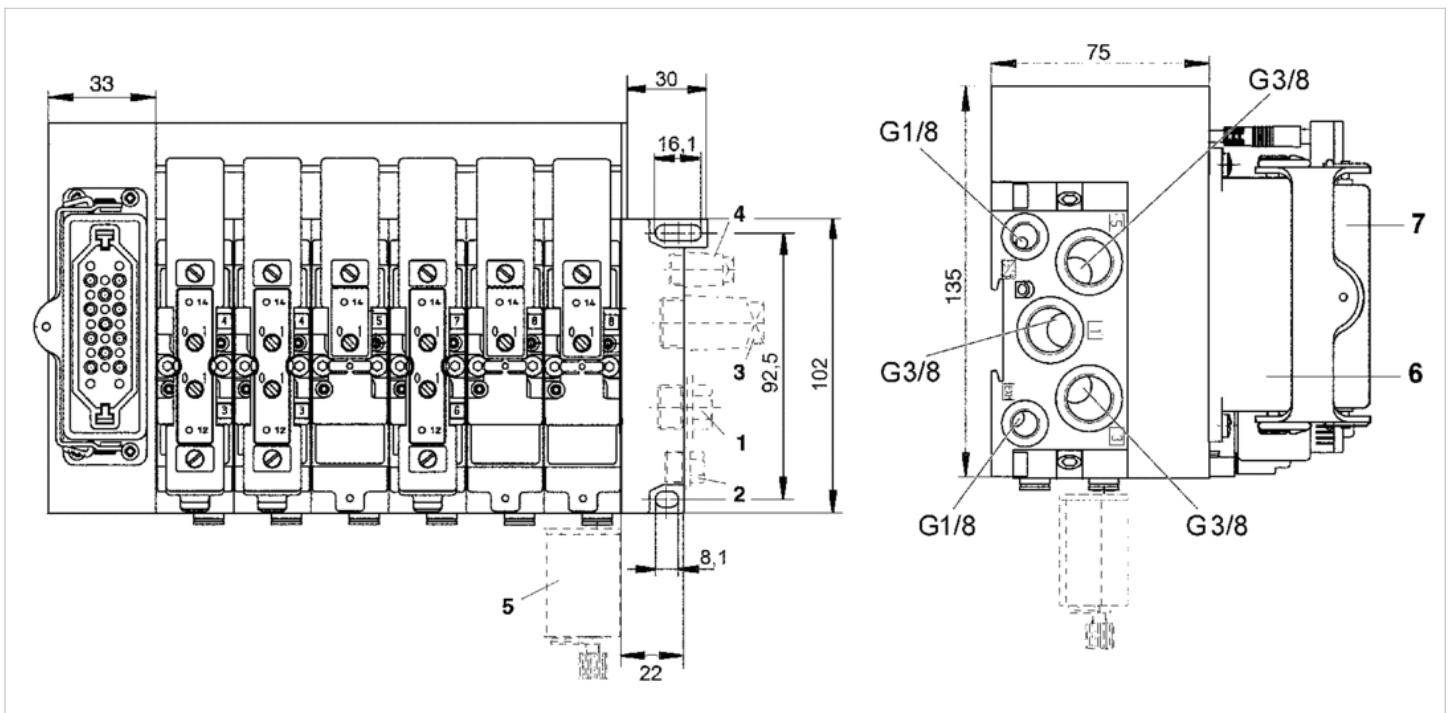

1) blanking screw G 3/8 2) blanking screw G 1/8 3) silencer G 3/8 4) silencer G 1/8 5) check-choke valve

6) multiple plug HAN (25 pins according to DIN 43652, lower part)

7) multiple plug HAN (25 pins according to DIN 43652, upper part)

An example configuration is illustrated. The delivered product may thus deviate from the illustration.

Dimensions, HAN multipole plug, 25-pin, top

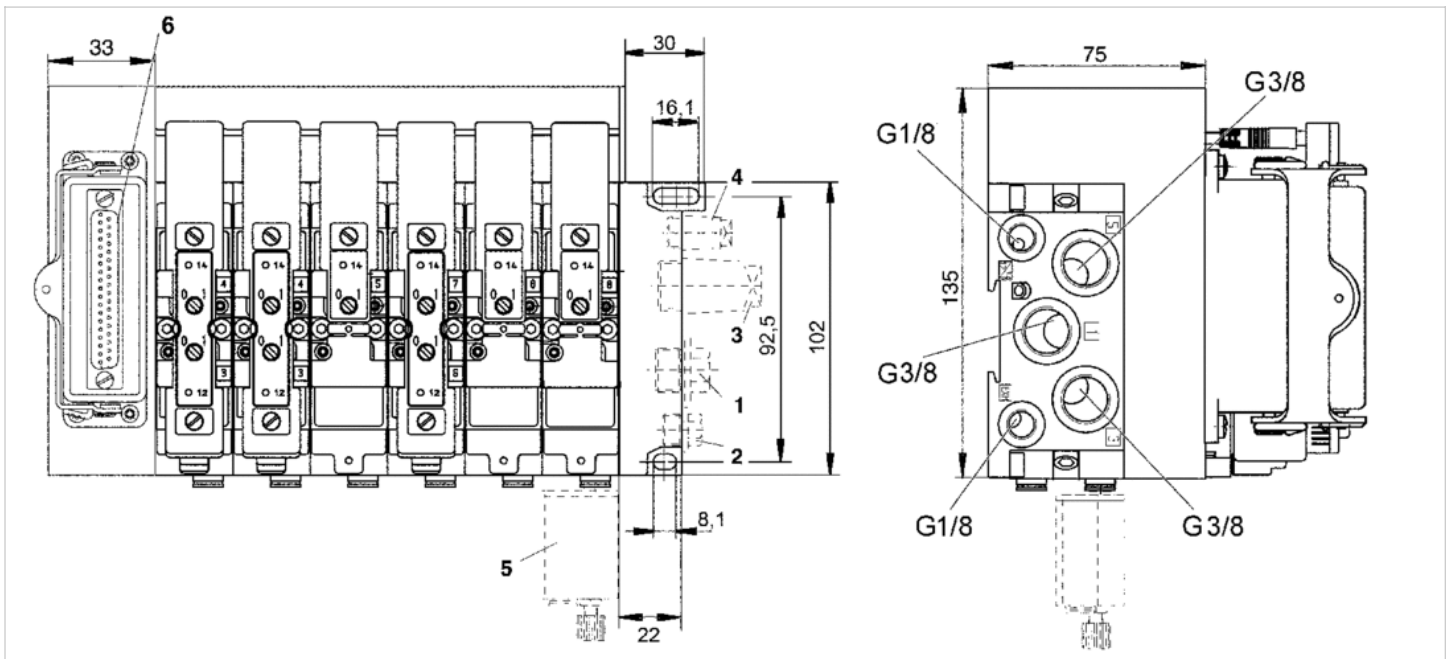

- 1) blanking screw G 3/8
 - 2) blanking screw G 1/8
 - 3) silencer G 3/8
 - 4) silencer G 1/8
 - 5) check-choke valve
 - 6) multipole plug (37 pins according to DIN 41652, lower part)
- An example configuration is illustrated. The delivered product may thus deviate from the illustration.







































2x3/2-directional valve, Series CD01-PA

- ISO 15407-1
- 26 mm
- 2x3/2
- NC/NC NO/NO NC/NO
- $Q_n = 1010 \text{ l/min}$
- Compressed air connection output base plate DIN ISO 15407-1
- Electrical connection Plug, EN 175301-803, form C
- Manual override with detent without detent



Version	Spool valve, positive overlapping
Sealing principle	Soft sealing
Connection type	Plate connection
Standards	ISO 15407-1, 26 mm
Connector standard	EN 175301-803, form C
Certificates	Free of substances that impair surface wetting in the coating process
Working pressure min./max.	See table below
Control pressure min./max.	See table below
Ambient temperature min./max.	-15 ... 50 °C
Medium temperature min./max.	-15 ... 50 °C
Medium	Compressed air
Max. particle size	50 µm
Oil content of compressed air	0 ... 5 mg/m ³
Nominal flow Q_n	See table below
Compressed air connection	according to ISO 15407-1
Protection class with connection	IP65
Duty cycle	100 %
Typ. switch-on time	See table below
Typ. switch-off time	See table below
Mounting screw	M4 with hexagon socket
Mounting screw tightening torque	2.5 Nm
Weight	0.25 kg

Technical data

Part No.			MO	Operational voltage DC	Operational voltage AC 50 Hz
5763990220		NC/NC		24 V	-
5763990620		NC/NC		24 V	-
5763995220		NC/NC		-	24 V
5763995270		NC/NC		-	110 V
5763995670		NC/NC		-	110 V
5763995280		NC/NC		-	230 V
5763970220		NO/NO		24 V	-
5763970620		NO/NO		24 V	-
5763975220		NO/NO		-	24 V
5763975270		NO/NO		-	110 V
5763975670		NO/NO		-	110 V
5763960220		NO/NO		24 V	-
5763960620		NO/NO		24 V	-
5763965270		NO/NO		-	110 V
5763965670		NO/NO		-	110 V
5763950220		NC/NO		24 V	-
5763950620		NC/NO		24 V	-
5763955270		NC/NO		-	110 V
5763955670		NC/NO		-	110 V

Part No.	Operational voltage AC 60 Hz	Voltage tolerance DC	Voltage tolerance AC 50 Hz	Voltage tolerance AC 60 Hz
5763990220	-	-10% / +10%	-	-
5763990620	-	-10% / +10%	-	-
5763995220	24 V	-	-10% / +15%	-10% / +15%
5763995270	110 V	-	-10% / +15%	-10% / +15%
5763995670	110 V	-	-10% / +15%	-10% / +15%
5763995280	230 V	-	-10% / +15%	-10% / +15%
5763970220	-	-10% / +10%	-	-
5763970620	-	-10% / +10%	-	-
5763975220	24 V	-	-10% / +15%	-10% / +15%
5763975270	110 V	-	-10% / +15%	-10% / +15%
5763975670	110 V	-	-10% / +15%	-10% / +15%
5763960220	-	-10% / +10%	-	-
5763960620	-	-10% / +10%	-	-
5763965270	110 V	-	-10% / +15%	-10% / +15%
5763965670	110 V	-	-10% / +15%	-10% / +15%
5763950220	-	-10% / +10%	-	-
5763950620	-	-10% / +10%	-	-
5763955270	110 V	-	-10% / +15%	-10% / +15%
5763955670	110 V	-	-10% / +15%	-10% / +15%

Part No.	Power consumption DC	Holding power AC 50 Hz	Holding power AC 60 Hz	Switch-on power AC 50 Hz
5763990220	1.6 W	-	-	-
5763990620	1.6 W	-	-	-
5763995220	-	2.2 VA	1.85 VA	3 VA
5763995270	-	3 VA	2.4 VA	4.2 VA
5763995670	-	3 VA	2.4 VA	4.2 VA
5763995280	-	2.3 VA	2 VA	3.2 VA
5763970220	1.6 W	-	-	-
5763970620	1.6 W	-	-	-
5763975220	-	2.2 VA	1.85 VA	3 VA
5763975270	-	3 VA	2.4 VA	4.2 VA
5763975670	-	3 VA	2.4 VA	4.2 VA
5763960220	1.6 W	-	-	-
5763960620	1.6 W	-	-	-
5763965270	-	3 VA	2.4 VA	4.2 VA
5763965670	-	3 VA	2.4 VA	4.2 VA
5763950220	1.6 W	-	-	-
5763950620	1.6 W	-	-	-
5763955270	-	3 VA	2.4 VA	4.2 VA
5763955670	-	3 VA	2.4 VA	4.2 VA

Part No.	Switch-on power AC 60 Hz	Pilot	Nominal flow Q _n	Nominal flow 1 ▶ 2
5763990220	-	Internal	1010 l/min	1010 l/min
5763990620	-	Internal	1010 l/min	1010 l/min
5763995220	2.6 VA	Internal	1010 l/min	1010 l/min
5763995270	3.4 VA	Internal	1010 l/min	1010 l/min
5763995670	3.4 VA	Internal	1010 l/min	1010 l/min
5763995280	2.8 VA	Internal	1010 l/min	1010 l/min
5763970220	-	Internal	-	800 l/min
5763970620	-	Internal	-	800 l/min
5763975220	2.6 VA	Internal	-	800 l/min
5763975270	3.4 VA	Internal	-	800 l/min
5763975670	3.4 VA	Internal	-	800 l/min
5763960220	-	External	-	800 l/min
5763960620	-	External	-	800 l/min
5763965270	3.4 VA	External	-	800 l/min
5763965670	3.4 VA	External	-	800 l/min
5763950220	-	Internal	1010 l/min	1010 l/min
5763950620	-	Internal	1010 l/min	1010 l/min
5763955270	3.4 VA	Internal	1010 l/min	1010 l/min
5763955670	3.4 VA	Internal	1010 l/min	1010 l/min

Part No.	Nominal flow 2 ▶ 3	Working pressure min./max.	Control pressure min./max.
5763990220	1010 l/min	-	2.5 ... 10 bar
5763990620	1010 l/min	-	2.5 ... 10 bar
5763995220	1010 l/min	-	2.5 ... 10 bar

Part No.	Nominal flow 2 ▶ 3	Working pressure min./max.	Control pressure min./max.
5763995270	1010 l/min	-	2.5 ... 10 bar
5763995670	1010 l/min	-	2.5 ... 10 bar
5763995280	1010 l/min	-	2.5 ... 10 bar
5763970220	700 l/min	3 bar	3 ... 10 bar
5763970620	700 l/min	3 bar	3 ... 10 bar
5763975220	700 l/min	3 bar	3 ... 10 bar
5763975270	700 l/min	3 bar	3 ... 10 bar
5763975670	700 l/min	3 bar	3 ... 10 bar
5763960220	700 l/min	0 ... 16 bar	10 bar
5763960620	700 l/min	0 ... 16 bar	10 bar
5763965270	700 l/min	0 ... 16 bar	10 bar
5763965670	700 l/min	0 ... 16 bar	10 bar
5763950220	1010 l/min	-	2.5 ... 10 bar
5763950620	1010 l/min	-	2.5 ... 10 bar
5763955270	1010 l/min	-	2.5 ... 10 bar
5763955670	1010 l/min	-	2.5 ... 10 bar

Part No.	Typ. switch-on time	Typ. switch-off time	Electrical connection Pilot valve
5763990220	27 ms	46 ms	Plug EN 175301-803, form C
5763990620	27 ms	46 ms	Plug EN 175301-803, form C
5763995220	27 ms	46 ms	Plug EN 175301-803, form C
5763995270	27 ms	46 ms	Plug EN 175301-803, form C
5763995670	27 ms	46 ms	Plug EN 175301-803, form C
5763995280	27 ms	46 ms	Plug EN 175301-803, form C
5763970220	26 ms	34 ms	Plug EN 175301-803, form C
5763970620	26 ms	34 ms	Plug EN 175301-803, form C
5763975220	26 ms	34 ms	Plug EN 175301-803, form C
5763975270	26 ms	34 ms	Plug EN 175301-803, form C
5763975670	26 ms	34 ms	Plug EN 175301-803, form C
5763960220	26 ms	34 ms	Plug EN 175301-803, form C
5763960620	26 ms	34 ms	Plug EN 175301-803, form C
5763965270	26 ms	34 ms	Plug EN 175301-803, form C
5763965670	26 ms	34 ms	Plug EN 175301-803, form C
5763950220	27 ms	46 ms	Plug EN 175301-803, form C
5763950620	27 ms	46 ms	Plug EN 175301-803, form C
5763955270	27 ms	46 ms	Plug EN 175301-803, form C
5763955670	27 ms	46 ms	Plug EN 175301-803, form C

Part No.	
5763990220	-
5763990620	-
5763995220	-
5763995270	-
5763995670	-
5763995280	-

5763970220	-
5763975220	-
5763975670	-
5763960620	1)
5763965670	1)
5763950620	-
5763955670	-

Nominal flow Qn at 6 bar and $\Delta p = 1$ bar, MO = Manual override

1) External control pressure: see diagram

Technical information

The min. control pressure must be adhered to, since otherwise faulty switching and valve failure may result!
 The pressure dew point must be at least 15 °C under ambient and medium temperature and may not exceed 3 °C .
 The oil content of compressed air must remain constant during the life cycle.
 Use only the approved oils from AVENTICS. Further information can be found in the “Technical information” document (available in the MediaCentre).

Versions with voltage of less than 50 V DC do not have a protective ground.

Technical information

Housing	Polyamide Polyoxymethylene
---------	----------------------------

Dimensions

Dimensions

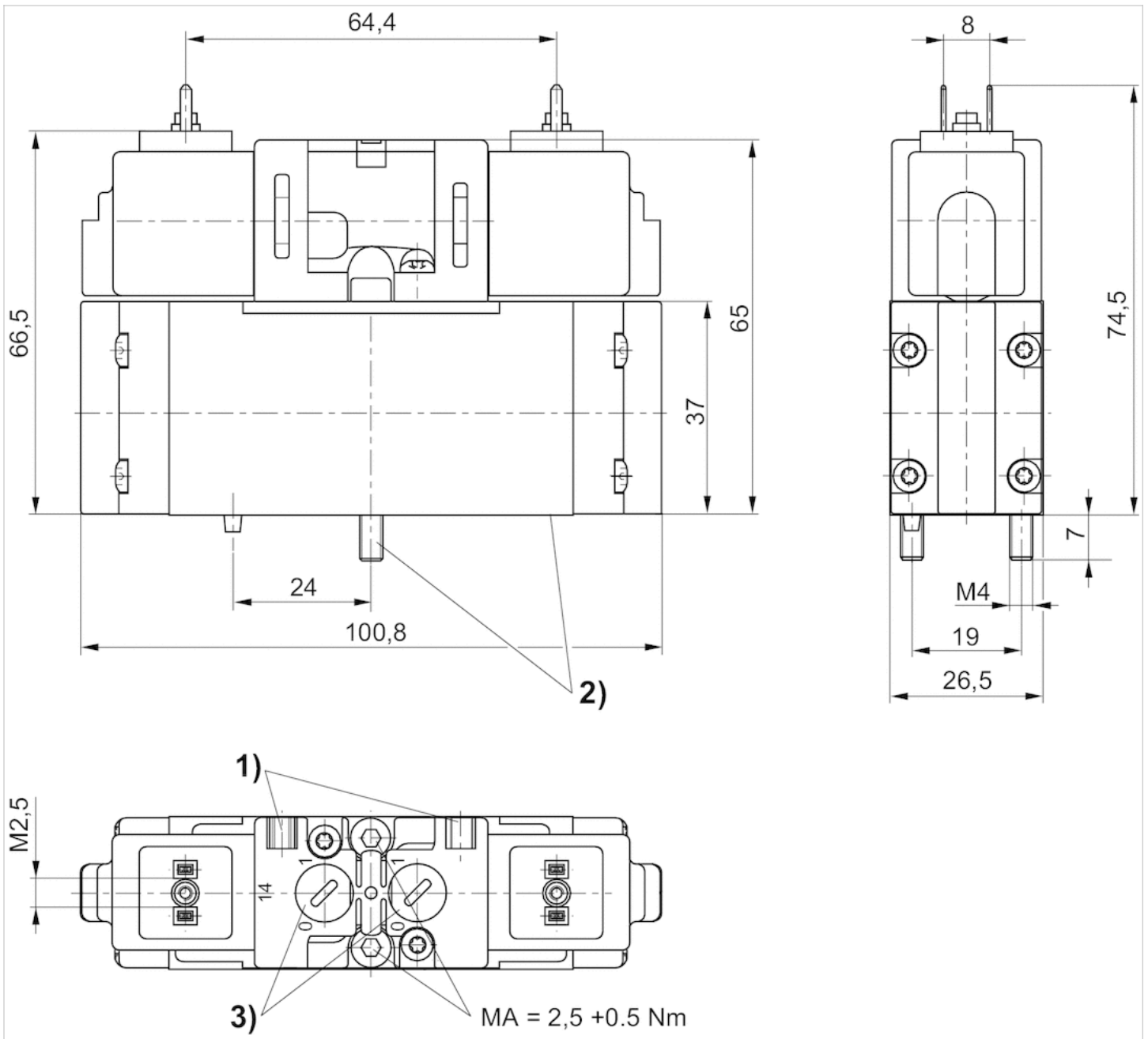

1) mounting space for name plate 2) screws and seals captive 3) manual override

Diagrams

Minimum control pressure for externally piloted valves (depending on the working pressure)

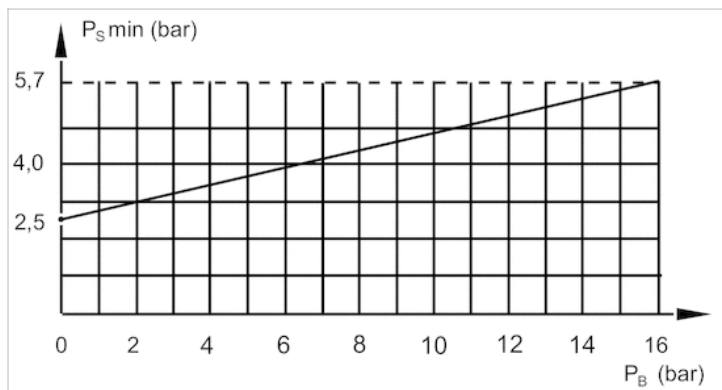

PB= Working pressure

PS = control pressure

















2x3/2-directional valve, Series CD01-PA

- ISO 15407-1
- 26 mm
- 2x3/2
- ISO 15407-1, 26 mm
- NC/NC NO/NO NC/NO
- $Q_n = 1010 \text{ l/min}$
- Compressed air connection output base plate DIN ISO 15407-1
- Electrical connection Plug, M12x1, 4-pin
- Manual override without detent with detent



Version	Spool valve, positive overlapping
Sealing principle	Soft sealing
Connection type	Plate connection
Standards	ISO 15407-1, 26 mm
Certificates	Free of substances that impair surface wetting in the coating process
Working pressure min./max.	See table below
Control pressure min./max.	See table below
Ambient temperature min./max.	-15 ... 50 °C
Medium temperature min./max.	-15 ... 50 °C
Medium	Compressed air
Max. particle size	50 µm
Oil content of compressed air	0 ... 5 mg/m ³
Nominal flow Q_n	See table below
Compressed air connection	according to ISO 15407-1
Protection class with connection	IP65
Protective circuit	43 V bi-directional
LED status display	Yellow
Duty cycle	100 %
Typ. switch-on time	See table below
Typ. switch-off time	See table below
Mounting screw	M4 with hexagon socket
Mounting screw tightening torque	2.5 Nm
Weight	0.28 kg

Technical data

Part No.			MO	Operational voltage DC	Voltage tolerance DC
5763990720		NC/NC		24 V	-10% / +10%
5763990520		NC/NC		24 V	-10% / +10%
5763960720		NO/NO		24 V	-10% / +10%
5763960520		NO/NO		24 V	-10% / +10%
5763970720		NO/NO		24 V	-10% / +10%
5763970520		NO/NO		24 V	-10% / +10%
5763950720		NC/NO		24 V	-10% / +10%
5763950520		NC/NO		24 V	-10% / +10%

Part No.	Power consumption DC	Pilot	Nominal flow Qn	Nominal flow 1 ▶ 2
5763990720	1.6 W	Internal	1010 l/min	1010 l/min
5763990520	1.6 W	Internal	1010 l/min	1010 l/min
5763960720	1.6 W	External	-	800 l/min
5763960520	1.6 W	External	-	800 l/min
5763970720	1.6 W	Internal	-	800 l/min
5763970520	1.6 W	Internal	-	800 l/min
5763950720	1.6 W	Internal	1010 l/min	1010 l/min
5763950520	1.6 W	Internal	1010 l/min	1010 l/min

Part No.	Nominal flow 2 ▶ 3	Working pressure min./max.	Control pressure min./max.
5763990720	1010 l/min	2.5 ... 10 bar	2.5 ... 10 bar
5763990520	1010 l/min	2.5 ... 10 bar	2.5 ... 10 bar
5763960720	700 l/min	0 ... 16 bar	10 bar
5763960520	700 l/min	0 ... 16 bar	10 bar
5763970720	700 l/min	3 ... 10 bar	3 ... 10 bar
5763970520	700 l/min	3 ... 10 bar	3 ... 10 bar
5763950720	1010 l/min	2.5 ... 10 bar	2.5 ... 10 bar
5763950520	1010 l/min	2.5 ... 10 bar	2.5 ... 10 bar

Part No.	Typ. switch-on time	Typ. switch-off time	Electrical connection Pilot valve	
5763990720	27 ms	46 ms	Plug M12x1 4-pin	-
5763990520	27 ms	46 ms	Plug M12x1 4-pin	-
5763960720	26 ms	34 ms	Plug M12x1 4-pin	1)
5763960520	26 ms	34 ms	Plug M12x1 4-pin	1)
5763970720	26 ms	34 ms	Plug M12x1 4-pin	-
5763970520	26 ms	34 ms	Plug M12x1 4-pin	-
5763950720	27 ms	46 ms	Plug M12x1 4-pin	-
5763950520	27 ms	46 ms	Plug M12x1 4-pin	-

Nominal flow Qn at 6 bar and $\Delta p = 1$ bar, MO = Manual override

1) Minimum control pressure for externally piloted valves (depending on the working pressure)

Technical information

The min. control pressure must be adhered to, since otherwise faulty switching and valve failure may result!

The pressure dew point must be at least 15 °C under ambient and medium temperature and may not exceed 3 °C .

The oil content of compressed air must remain constant during the life cycle.

Use only the approved oils from AVENTICS. Further information can be found in the "Technical information" document (available in the MediaCentre).

Technical information

Housing	Polyamide Polyoxymethylene

Dimensions

Dimensions

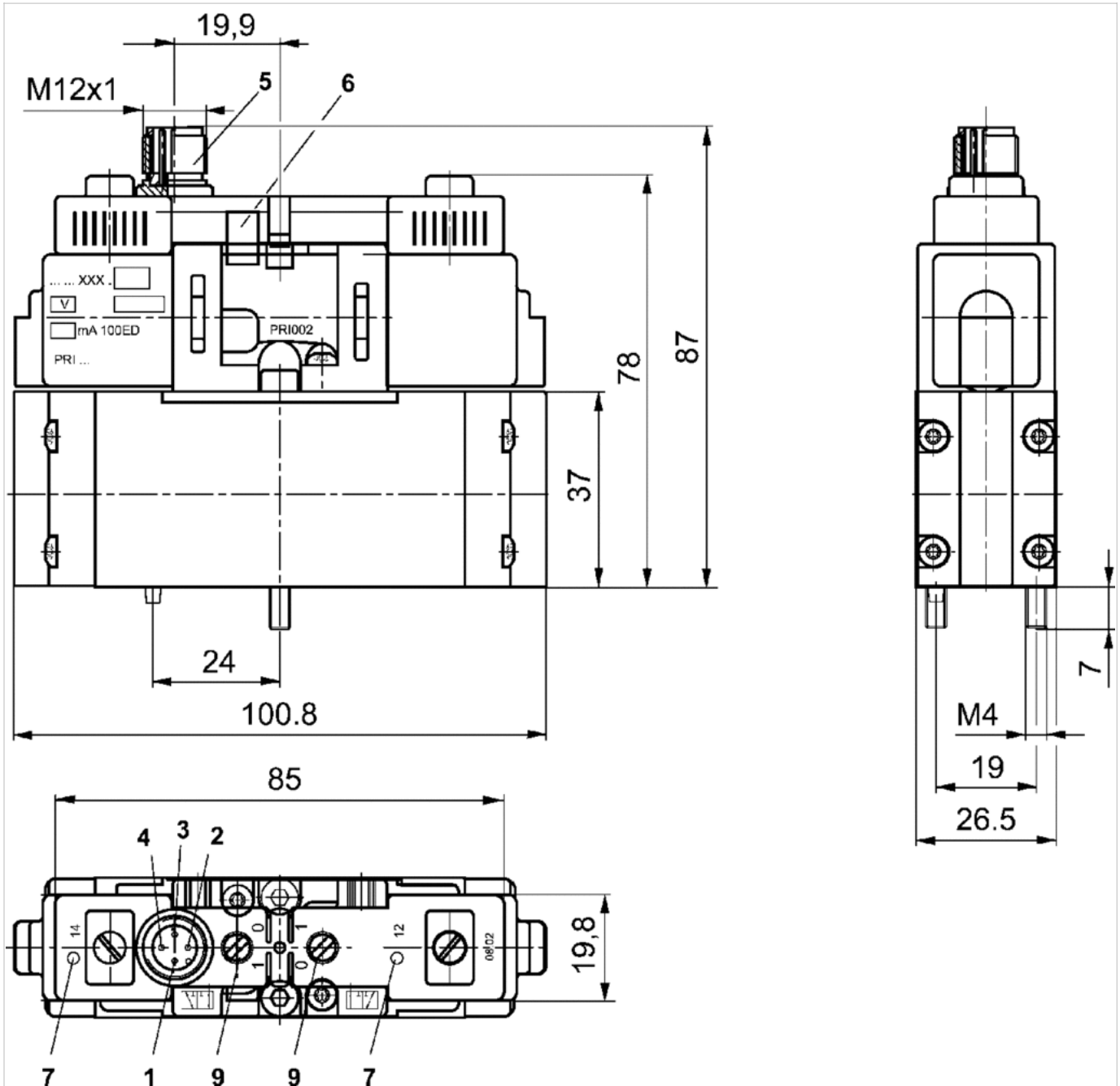

1) not assigned 2) magnet 12 3) 0 V 4) magnet 14 5) metal round plug M12x1 6) positioning pin 7) yellow valve switching state LED 9) manual override

Diagrams

Minimum control pressure for externally piloted valves (depending on the working pressure)

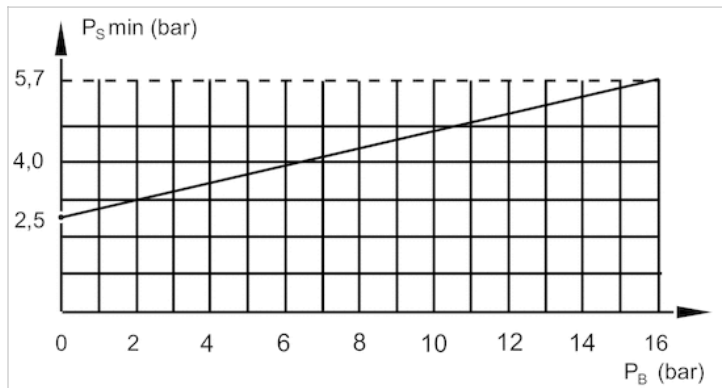

PB= Working pressure

PS = control pressure





























5/2-directional valve, Series CD01-PA

- ISO 15407-1
- 26 mm
- 5/2
- With air spring return With spring/air spring return
- single solenoid
- $Q_n = 1010 \text{ l/min}$
- Compressed air connection output base plate DIN ISO 15407-1
- Electrical connection Plug, EN 175301-803, form C
- Manual override with detent without detent



Version	Spool valve, positive overlapping
Sealing principle	Soft sealing
Connection type	Plate connection
Standards	ISO 15407-1, 26 mm
Connector standard	EN 175301-803, form C
Certificates	Free of substances that impair surface wetting in the coating process
Working pressure min./max.	See table below
Control pressure min./max.	See table below
Ambient temperature min./max.	See table below
Medium temperature min./max.	See table below
Medium	Compressed air
Max. particle size	50 μm
Oil content of compressed air	0 ... 5 mg/m^3
Nominal flow Q_n	1010 l/min
Compressed air connection	according to ISO 15407-1
Protection class with connection	IP65
Duty cycle	100 %
Typ. switch-on time	See table below
Typ. switch-off time	See table below
Mounting screw	M4 with hexagon socket
Mounting screw tightening torque	2.5 Nm
Weight	0.21 kg

Technical data

Part No.		MO	Operational voltage DC	Operational voltage AC 50 Hz
5763510210			12 V	-
5763510220			24 V	-
5763510620			24 V	-
5763510920			24 V	-
5763515220			-	24 V
5763515270			-	110 V
5763515670			-	110 V
5763515280			-	230 V
5763600220			24 V	-
5763600620			24 V	-
5763605220			-	24 V
5763605270			-	110 V
5763605670			-	110 V
5763605280			-	230 V

Part No.	Operational voltage AC 60 Hz	Voltage tolerance DC	Voltage tolerance AC 50 Hz	Voltage tolerance AC 60 Hz
5763510210	-	-10% / +10%	-	-
5763510220	-	-10% / +10%	-	-
5763510620	-	-10% / +10%	-	-
5763510920	-	-10% / +10%	-	-
5763515220	24 V	-	-10% / +15%	-10% / +15%
5763515270	110 V	-	-10% / +15%	-10% / +15%
5763515670	110 V	-	-10% / +15%	-10% / +15%
5763515280	230 V	-	-10% / +15%	-10% / +15%
5763600220	-	-10% / +10%	-	-
5763600620	-	-10% / +10%	-	-
5763605220	24 V	-	-10% / +15%	-10% / +15%
5763605270	110 V	-	-10% / +15%	-10% / +15%
5763605670	110 V	-	-10% / +15%	-10% / +15%
5763605280	230 V	-	-10% / +15%	-10% / +15%

Part No.	Power consumption DC	Holding power AC 50 Hz	Holding power AC 60 Hz	Switch-on power AC 50 Hz
5763510210	1.6 W	-	-	-
5763510220	1.6 W	-	-	-
5763510620	1.6 W	-	-	-
5763510920	2.06 W	-	-	-
5763515220	-	2.2 VA	1.85 VA	3 VA
5763515270	-	3 VA	2.4 VA	4.2 VA
5763515670	-	3 VA	2.4 VA	4.2 VA
5763515280	-	2.3 VA	2 VA	3.2 VA
5763600220	1.6 W	-	-	-

Part No.	Power consumption DC	Holding power AC 50 Hz	Holding power AC 60 Hz	Switch-on power AC 50 Hz
5763600620	1.6 W	-	-	-
5763605220	-	2.2 VA	1.85 VA	3 VA
5763605270	-	3 VA	2.4 VA	4.2 VA
5763605670	-	3 VA	2.4 VA	4.2 VA
5763605280	-	2.3 VA	2 VA	3.2 VA

Part No.	Switch-on power AC 60 Hz	Pilot	Nominal flow 1 ► 2	Nominal flow 2 ► 3
5763510210	-	Internal	1010 l/min	1010 l/min
5763510220	-	Internal	1010 l/min	1010 l/min
5763510620	-	Internal	1010 l/min	1010 l/min
5763510920	-	Internal	1010 l/min	1010 l/min
5763515220	2.6 VA	Internal	1010 l/min	1010 l/min
5763515270	3.4 VA	Internal	1010 l/min	1010 l/min
5763515670	3.4 VA	Internal	1010 l/min	1010 l/min
5763515280	2.8 VA	Internal	1010 l/min	1010 l/min
5763600220	-	External	1010 l/min	1010 l/min
5763600620	-	External	1010 l/min	1010 l/min
5763605220	2.6 VA	External	1010 l/min	1010 l/min
5763605270	3.4 VA	External	1010 l/min	1010 l/min
5763605670	3.4 VA	External	1010 l/min	1010 l/min
5763605280	2.8 VA	External	1010 l/min	1010 l/min

Part No.	Working pressure min./max.	Control pressure min./max.
5763510210	3 ... 10 bar	3 ... 10 bar
5763510220	3 ... 10 bar	3 ... 10 bar
5763510620	3 ... 10 bar	3 ... 10 bar
5763510920	2 ... 16 bar	2 ... 16 bar
5763515220	3 ... 10 bar	3 ... 10 bar
5763515270	3 ... 10 bar	3 ... 10 bar
5763515670	3 ... 10 bar	3 ... 10 bar
5763515280	3 ... 10 bar	3 ... 10 bar
5763600220	0 ... 16 bar	3 ... 10 bar
5763600620	0 ... 16 bar	3 ... 10 bar
5763605220	0 ... 16 bar	3 ... 10 bar
5763605270	0 ... 16 bar	3 ... 10 bar
5763605670	0 ... 16 bar	3 ... 10 bar
5763605280	0 ... 16 bar	3 ... 10 bar

Part No.	Ambient temperature min./max.	Medium temperature min./max.
5763510210	-15 ... 50 °C	-15 ... 50 °C
5763510220	-15 ... 50 °C	-15 ... 50 °C
5763510620	-15 ... 50 °C	-15 ... 50 °C
5763510920	0 ... 50 °C	0 ... 50 °C
5763515220	-15 ... 50 °C	-15 ... 50 °C

Part No.	Ambient temperature min./max.	Medium temperature min./max.
5763515270	-15 ... 50 °C	-15 ... 50 °C
5763515670	-15 ... 50 °C	-15 ... 50 °C
5763515280	-15 ... 50 °C	-15 ... 50 °C
5763600220	-15 ... 50 °C	-15 ... 50 °C
5763600620	-15 ... 50 °C	-15 ... 50 °C
5763605220	-15 ... 50 °C	-15 ... 50 °C
5763605270	-15 ... 50 °C	-15 ... 50 °C
5763605670	-15 ... 50 °C	-15 ... 50 °C
5763605280	-15 ... 50 °C	-15 ... 50 °C

Part No.	Typ. switch-on time	Typ. switch-off time	Electrical connection Pilot valve
5763510210	29 ms	42 ms	Plug EN 175301-803, form C
5763510220	29 ms	42 ms	Plug EN 175301-803, form C
5763510620	29 ms	42 ms	Plug EN 175301-803, form C
5763510920	29 ms	42 ms	Plug EN 175301-803, form C
5763515220	29 ms	42 ms	Plug EN 175301-803, form C
5763515270	29 ms	42 ms	Plug EN 175301-803, form C
5763515670	29 ms	42 ms	Plug EN 175301-803, form C
5763515280	29 ms	42 ms	Plug EN 175301-803, form C
5763600220	34 ms	35 ms	Plug EN 175301-803, form C
5763600620	34 ms	35 ms	Plug EN 175301-803, form C
5763605220	34 ms	35 ms	Plug EN 175301-803, form C
5763605270	34 ms	35 ms	Plug EN 175301-803, form C
5763605670	34 ms	35 ms	Plug EN 175301-803, form C
5763605280	34 ms	35 ms	Plug EN 175301-803, form C

Part No.	Power consumption	
5763510210	-	-
5763510220	-	-
5763510620	-	-
5763510920	Low power consumption	-
5763515220	-	-
5763515270	-	-
5763515670	-	-
5763515280	-	-
5763600220	-	1)
5763600620	-	1)
5763605220	-	1)
5763605270	-	1)
5763605670	-	1)
5763605280	-	1)

Nominal flow Q_n at 6 bar and $\Delta p = 1$ bar, MO = Manual override

1) Control pressure: see diagram for min., max. 10 bar

Technical information

The min. control pressure must be adhered to, since otherwise faulty switching and valve failure may result!
 The pressure dew point must be at least 15 °C under ambient and medium temperature and may not exceed 3 °C .
 The oil content of compressed air must remain constant during the life cycle.
 Use only the approved oils from AVENTICS. Further information can be found in the “Technical information” document (available in the MediaCentre).

Versions with voltage of less than 50 V DC do not have a protective ground.

Technical information

Housing	Polyamide Polyoxymethylene

Dimensions

Dimensions

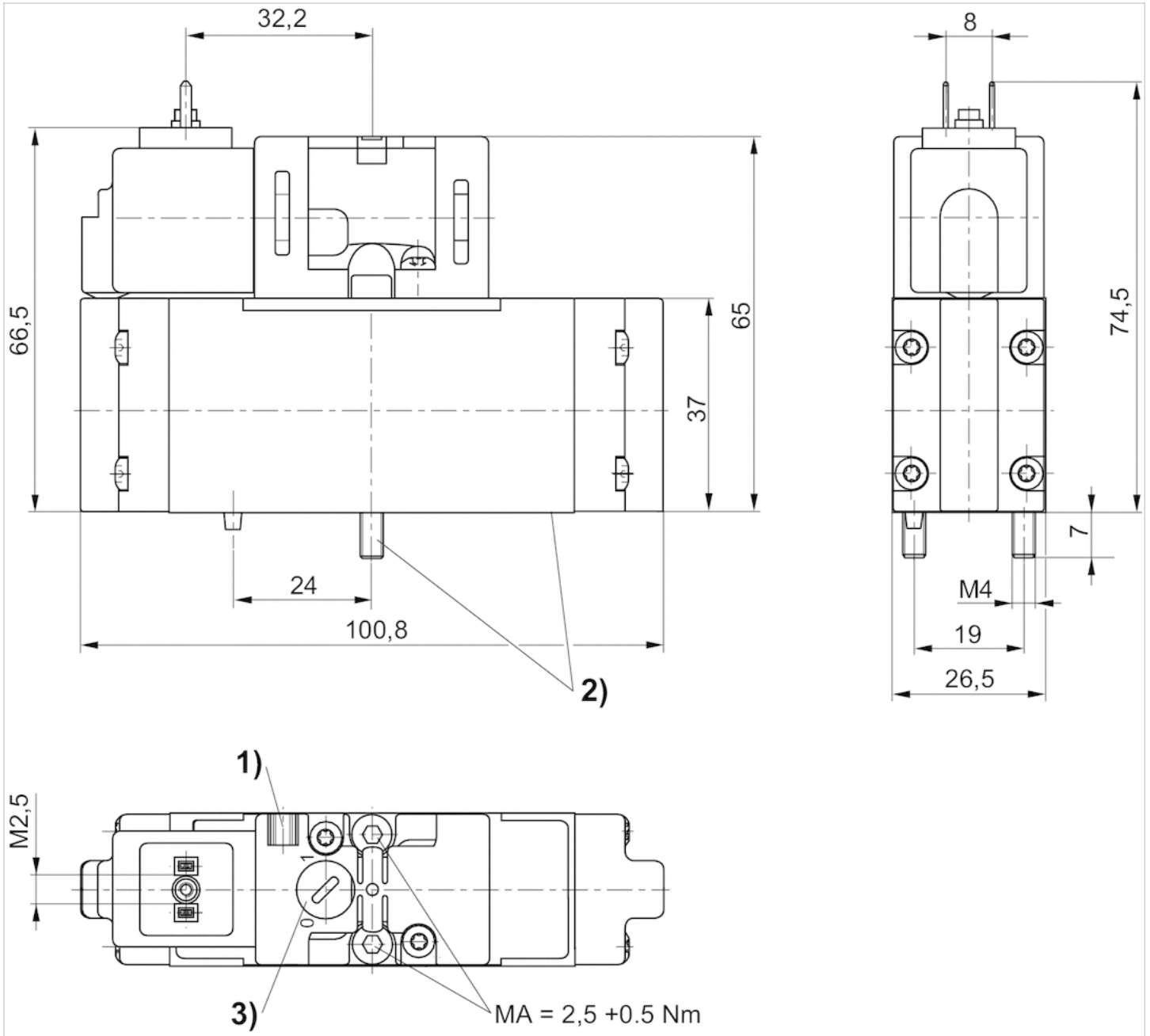

1) mounting space for name plate 2) screws and seals captive 3) manual override

Diagrams

Minimum control pressure for externally piloted valves (depending on the working pressure)

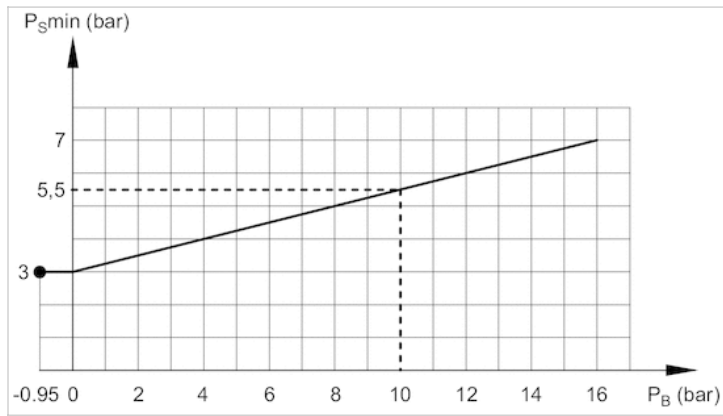

PB= Working pressure

PS = control pressure

































5/2-directional valve, Series CD01-PA

- ISO 15407-1
- 26 mm
- 5/2
- double solenoid
- Qn = 1010 l/min
- Compressed air connection output base plate DIN ISO 15407-1
- Electrical connection Plug, EN 175301-803, form C
- Manual override with detent without detent without



Version	Spool valve, positive overlapping
Sealing principle	Soft sealing
Connection type	Plate connection
Standards	ISO 15407-1, 26 mm
Connector standard	EN 175301-803
Certificates	Free of substances that impair surface wetting in the coating process
Working pressure min./max.	See table below
Control pressure min./max.	2 ... 10 bar
Ambient temperature min./max.	See table below
Medium temperature min./max.	See table below
Medium	Compressed air
Max. particle size	50 µm
Oil content of compressed air	0 ... 5 mg/m ³
Nominal flow Qn	1010 l/min
Compressed air connection	according to ISO 15407-1
Protection class with connection	IP65
Duty cycle	100 %
Typ. switch-on time	17 ms
Typ. switch-off time	17 ms
Mounting screw	M4 with hexagon socket
Mounting screw tightening torque	2.5 Nm
Weight	0.26 kg

Technical data

Part No.		MO	Operational voltage DC	Operational voltage AC 50 Hz
5763520220			24 V	-
5763520620			24 V	-
5763525220			-	24 V
5763525270			-	110 V
5763525670			-	110 V
5763525280			-	230 V
5763650220			24 V	-
5763650620			24 V	-
5763655270			-	110 V
5763655670			-	110 V
5763655280			-	230 V
5763530220			24 V	-
5763530620			24 V	-
5763530920			24 V	-
5763535270			-	110 V
5763535670			-	110 V

Part No.	Operational voltage AC 60 Hz	Voltage tolerance DC	Voltage tolerance AC 50 Hz	Voltage tolerance AC 60 Hz
5763520220	-	-10% / +10%	-	-
5763520620	-	-10% / +10%	-	-
5763525220	24 V	-	-10% / +15%	-10% / +15%
5763525270	110 V	-	-10% / +15%	-10% / +15%
5763525670	110 V	-	-10% / +15%	-10% / +15%
5763525280	230 V	-	-10% / +15%	-10% / +15%
5763650220	-	-10% / +10%	-	-
5763650620	-	-10% / +10%	-	-
5763655270	110 V	-	-10% / +15%	-10% / +15%
5763655670	110 V	-	-10% / +15%	-10% / +15%
5763655280	230 V	-	-10% / +15%	-10% / +15%
5763530220	-	-10% / +10%	-	-
5763530620	-	-10% / +10%	-	-
5763530920	-	-10% / +10%	-	-
5763535270	110 V	-	-10% / +15%	-10% / +15%
5763535670	110 V	-	-10% / +15%	-10% / +15%

Part No.	Power consumption DC	Holding power AC 50 Hz	Holding power AC 60 Hz	Switch-on power AC 50 Hz
5763520220	1.6 W	-	-	-
5763520620	1.6 W	-	-	-
5763525220	-	2.2 VA	1.85 VA	3 VA
5763525270	-	3 VA	2.4 VA	4.2 VA
5763525670	-	3 VA	2.4 VA	4.2 VA

Part No.	Power consumption DC	Holding power AC 50 Hz	Holding power AC 60 Hz	Switch-on power AC 50 Hz
5763525280	-	2.3 VA	2 VA	3.2 VA
5763650220	1.6 W	-	-	-
5763650620	1.6 W	-	-	-
5763655270	-	3 VA	2.4 VA	4.2 VA
5763655670	-	3 VA	2.4 VA	4.2 VA
5763655280	-	2.3 VA	2 VA	3.2 VA
5763530220	1.6 W	-	-	-
5763530620	1.6 W	-	-	-
5763530920	2.06 W	-	-	-
5763535270	-	3 VA	2.4 VA	4.2 VA
5763535670	-	3 VA	2.4 VA	4.2 VA

Part No.	Switch-on power AC 60 Hz	Pilot	Nominal flow 1 ▶ 2	Nominal flow 2 ▶ 3
5763520220	-	Internal	1010 l/min	1010 l/min
5763520620	-	Internal	1010 l/min	1010 l/min
5763525220	2.6 VA	Internal	1010 l/min	1010 l/min
5763525270	3.4 VA	Internal	1010 l/min	1010 l/min
5763525670	3.4 VA	Internal	1010 l/min	1010 l/min
5763525280	2.8 VA	Internal	1010 l/min	1010 l/min
5763650220	-	External	1010 l/min	1010 l/min
5763650620	-	External	1010 l/min	1010 l/min
5763655270	3.4 VA	External	1010 l/min	1010 l/min
5763655670	3.4 VA	External	1010 l/min	1010 l/min
5763655280	2.8 VA	External	1010 l/min	1010 l/min
5763530220	-	Internal	1010 l/min	1010 l/min
5763530620	-	Internal	1010 l/min	1010 l/min
5763530920	-	Internal	1010 l/min	1010 l/min
5763535270	3.4 VA	Internal	1010 l/min	1010 l/min
5763535670	3.4 VA	Internal	1010 l/min	1010 l/min

Part No.	Working pressure min./max.	Ambient temperature min./max.
5763520220	2 ... 10 bar	-15 ... 50 °C
5763520620	2 ... 10 bar	-15 ... 50 °C
5763525220	2 ... 10 bar	-15 ... 50 °C
5763525270	2 ... 10 bar	-15 ... 50 °C
5763525670	2 ... 10 bar	-15 ... 50 °C
5763525280	2 ... 10 bar	-15 ... 50 °C
5763650220	-0.95 ... 16 bar	-15 ... 50 °C
5763650620	-0.95 ... 16 bar	-15 ... 50 °C
5763655270	-0.95 ... 16 bar	-15 ... 50 °C
5763655670	-0.95 ... 16 bar	-15 ... 50 °C
5763655280	-0.95 ... 16 bar	-15 ... 50 °C
5763530220	2 ... 10 bar	-15 ... 50 °C
5763530620	2 ... 10 bar	-15 ... 50 °C
5763530920	2 ... 16 bar	0 ... 50 °C

Part No.	Working pressure min./max.	Ambient temperature min./max.
5763535270	2 ... 10 bar	-15 ... 50 °C
5763535670	2 ... 10 bar	-15 ... 50 °C

Part No.	Medium temperature min./max.	Electrical connection Pilot valve
5763520220	-15 ... 50 °C	Plug EN 175301-803, form C
5763520620	-15 ... 50 °C	Plug EN 175301-803, form C
5763525220	-15 ... 50 °C	Plug EN 175301-803, form C
5763525270	-15 ... 50 °C	Plug EN 175301-803, form C
5763525670	-15 ... 50 °C	Plug EN 175301-803, form C
5763525280	-15 ... 50 °C	Plug EN 175301-803, form C
5763650220	-15 ... 50 °C	Plug EN 175301-803, form C
5763650620	-15 ... 50 °C	Plug EN 175301-803, form C
5763655270	-15 ... 50 °C	Plug EN 175301-803, form C
5763655670	-15 ... 50 °C	Plug EN 175301-803, form C
5763655280	-15 ... 50 °C	Plug EN 175301-803, form C
5763530220	-15 ... 50 °C	Plug EN 175301-803, form C
5763530620	-15 ... 50 °C	Plug EN 175301-803, form C
5763530920	0 ... 50 °C	Plug EN 175301-803, form C
5763535270	-15 ... 50 °C	Plug EN 175301-803, form C
5763535670	-15 ... 50 °C	Plug EN 175301-803, form C

Part No.	Power consumption
5763520220	-
5763520620	-
5763525220	-
5763525270	-
5763525670	-
5763525280	-
5763650220	-
5763650620	-
5763655270	-
5763655670	-
5763655280	-
5763530220	-
5763530620	-
5763530920	Low power consumption
5763535270	-
5763535670	-

Nominal flow Qn at 6 bar and $\Delta p = 1$ bar, MO = Manual override

Technical information

The min. control pressure must be adhered to, since otherwise faulty switching and valve failure may result!
The pressure dew point must be at least 15 °C under ambient and medium temperature and may not exceed 3 °C .
The oil content of compressed air must remain constant during the life cycle.
Use only the approved oils from AVENTICS. Further information can be found in the “Technical information” document (available in the MediaCentre).
Versions with voltage of less than 50 V DC do not have a protective ground.

Technical information

Housing	
Polyamide Polyoxymethylene	

Dimensions

Dimensions

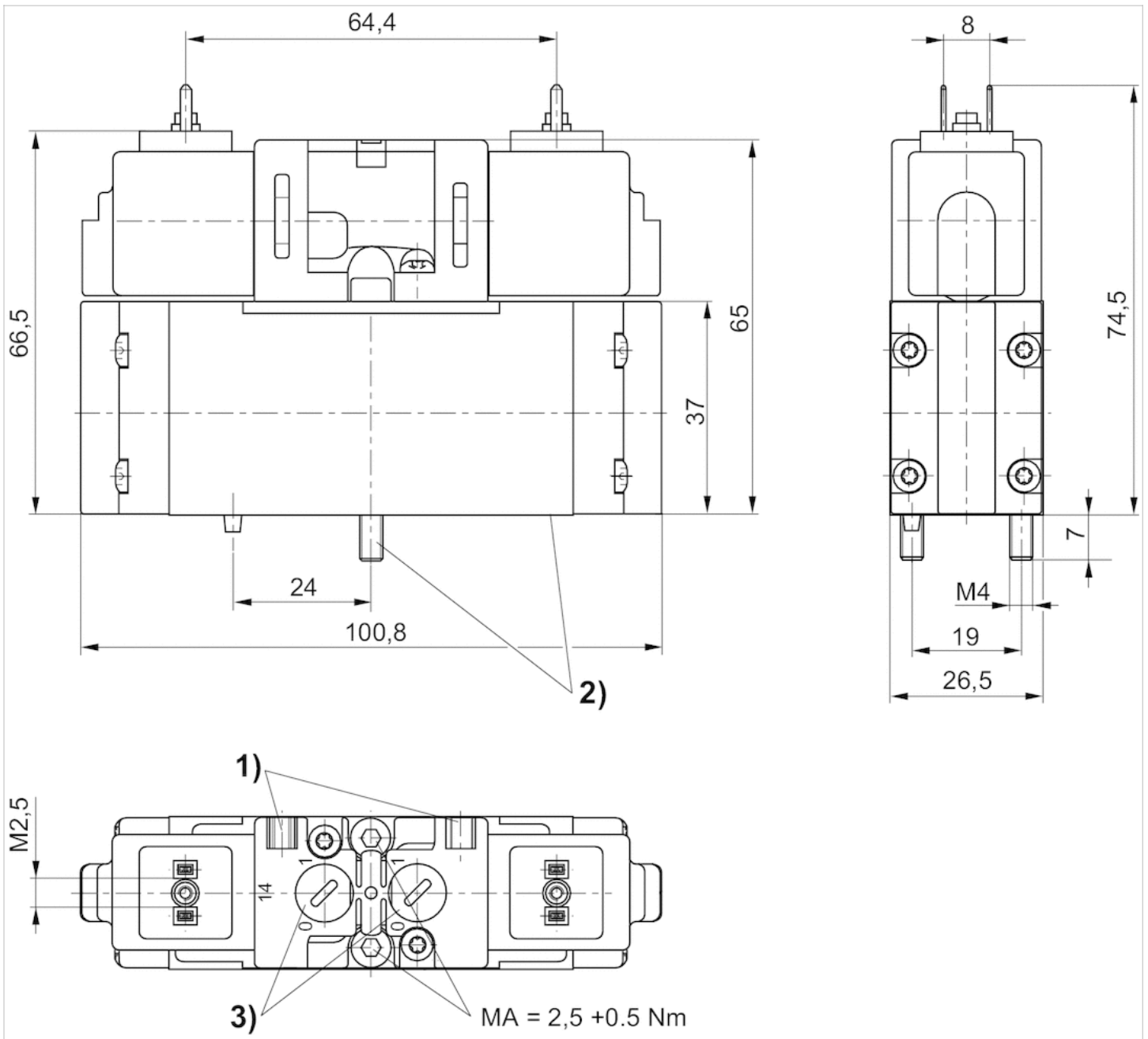

1) mounting space for name plate 2) screws and seals captive 3) manual override





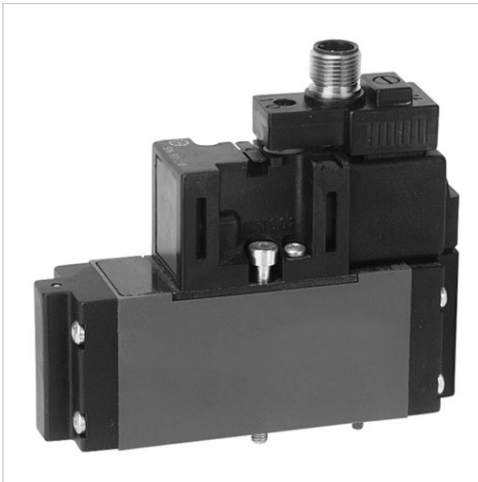



5/2-directional valve, Series CD01-PA

- ISO 15407-1
- 26 mm
- 5/2
- ISO 15407-1, 26 mm
- With air spring return With spring/air spring return
- single solenoid
- $Q_n = 1010 \text{ l/min}$
- Compressed air connection output base plate DIN ISO 15407-1
- Electrical connection Plug, M12x1, 4-pin
- Manual override without detent with detent



Version	Spool valve, positive overlapping
Sealing principle	Soft sealing
Connection type	Plate connection
Standards	ISO 15407-1, 26 mm
Certificates	Free of substances that impair surface wetting in the coating process
Working pressure min./max.	See table below
Control pressure min./max.	See table below
Ambient temperature min./max.	-15 ... 50 °C
Medium temperature min./max.	-15 ... 50 °C
Medium	Compressed air
Max. particle size	50 µm
Oil content of compressed air	0 ... 5 mg/m ³
Nominal flow Q_n	1010 l/min
Compressed air connection	according to ISO 15407-1
Protection class with connection	IP65
Protective circuit	43 V bi-directional
LED status display	Yellow
Duty cycle	100 %
Typ. switch-on time	See table below
Typ. switch-off time	See table below
Mounting screw	M4 with hexagon socket
Mounting screw tightening torque	2.5 Nm
Weight	0.23 kg

Technical data

Part No.		MO	Operational voltage DC	Voltage tolerance DC
5763510720			24 V	-10% / +10%
5763510520			24 V	-10% / +10%
5763600720			24 V	-10% / +10%
5763600520			24 V	-10% / +10%

Part No.	Power	MO	Flow rate	Flow rate
5763510720	1.6 W	Internal	1010 l/min	1010 l/min
5763600720	1.6 W	External	1010 l/min	1010 l/min

Part No.	Pressure range	Pressure	Response time
5763510720	3 ... 10 bar	3 ... 10 bar	29 ms
5763600720	0 ... 16 bar	10 bar	34 ms

Part No.	Response time	Connector	Notes
5763510720	42 ms	Plug M12x1 4-pin	-
5763600720	35 ms	Plug M12x1 4-pin	1)

Nominal flow Q_n with secondary pressure 6 bar at $\Delta p = 1$ bar, MO = Manual override

1) External control pressure: see diagram

Technical information

The min. control pressure must be adhered to, since otherwise faulty switching and valve failure may result!

The pressure dew point must be at least 15 °C under ambient and medium temperature and may not exceed 3 °C .

The oil content of compressed air must remain constant during the life cycle.

Use only the approved oils from AVENTICS. Further information can be found in the "Technical information" document (available in the MediaCentre).

Technical information

Housing	Polyamide Polyoxymethylene
---------	----------------------------

Dimensions

Dimensions

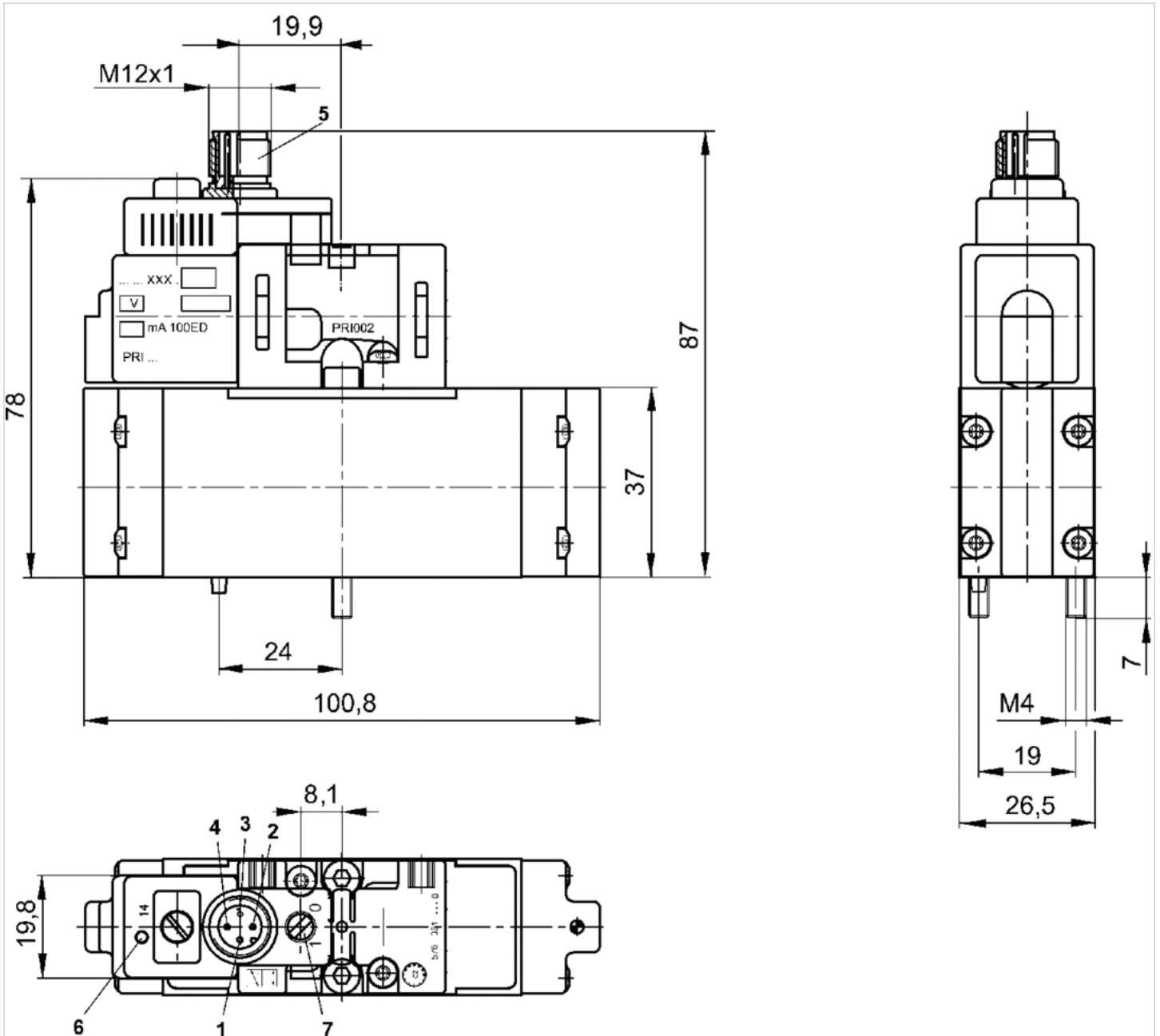

1) not assigned 2) not assigned 12 3) 0 V 4) magnet 14 5) metal round plug M12x1 6) yellow valve switching state LED 7) manual override

Diagrams

Minimum control pressure for externally piloted valves (depending on the working pressure)

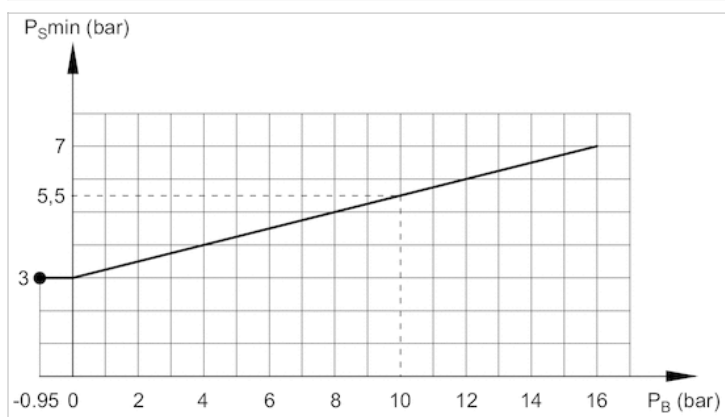

P_B = Working pressure

P_S = control pressure









5/2-directional valve, Series CD01-PA

- ISO 15407-1
- 26 mm
- 5/2
- ISO 15407-1, 26 mm
- double solenoid
- $Q_n = 1010 \text{ l/min}$
- Compressed air connection output base plate DIN ISO 15407-1
- Electrical connection Plug, M12x1, 4-pin
- Manual override without detent with detent



Version	Spool valve, positive overlapping
Sealing principle	Soft sealing
Connection type	Plate connection
Standards	ISO 15407-1, 26 mm
Certificates	Free of substances that impair surface wetting in the coating process
Working pressure min./max.	See table below
Control pressure min./max.	2 ... 10 bar
Ambient temperature min./max.	-15 ... 50 °C
Medium temperature min./max.	-15 ... 50 °C
Medium	Compressed air
Max. particle size	50 µm
Oil content of compressed air	0 ... 5 mg/m ³
Nominal flow Q_n	1010 l/min
Compressed air connection	according to ISO 15407-1
Protection class with connection	IP65
Protective circuit	43 V bi-directional
LED status display	Yellow
Duty cycle	100 %
Typ. switch-on time	17 ms
Typ. switch-off time	17 ms
Mounting screw	M4 with hexagon socket
Mounting screw tightening torque	2.5 Nm
Weight	0.29 kg

Technical data

Part No.		MO	Operational voltage DC	Voltage tolerance DC
5763520720			24 V	-10% / +10%
5763520520			24 V	-10% / +10%
5763650720			24 V	-10% / +10%
5763650520			24 V	-10% / +10%

Part No.	Power consumption DC	Pilot	Nominal flow 1 ▶ 2	Nominal flow 2 ▶ 3
5763520720	1.6 W	Internal	1010 l/min	1010 l/min

5763650720	1.6 W	External	1010 l/min	1010 l/min

5763520720	2 ... 10 bar		Plug M12x1 4-pin
5763650720	-0.95 ... 16 bar		Plug M12x1 4-pin

Nominal flow Qn at 6 bar and $\Delta p = 1$ bar, MO = Manual override

Technical information

The min. control pressure must be adhered to, since otherwise faulty switching and valve failure may result!

The pressure dew point must be at least 15 °C under ambient and medium temperature and may not exceed 3 °C .

The oil content of compressed air must remain constant during the life cycle.

Use only the approved oils from AVENTICS. Further information can be found in the "Technical information" document (available in the MediaCentre).

Technical information

Housing	Polyamide Polyoxymethylene

Dimensions

Dimensions

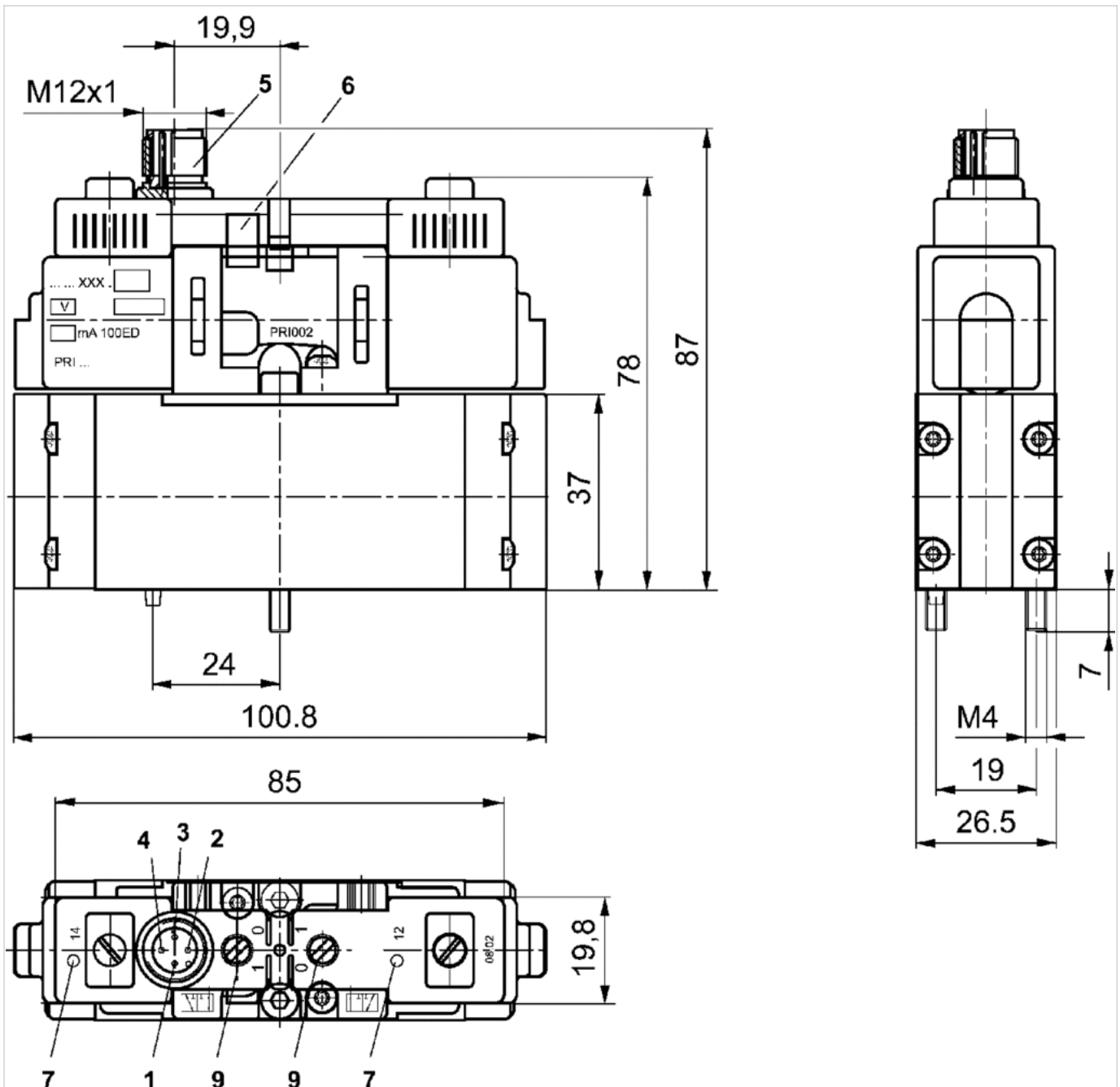

- 1) not assigned 2) magnet 12 3) 0 V 4) magnet 14 5) metal round plug M12x1 6) positioning pin 7) yellow valve switching state LED 9) manual override











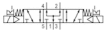

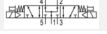

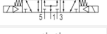

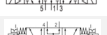



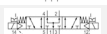

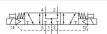



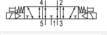

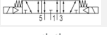

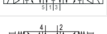

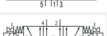







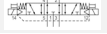





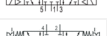

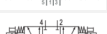



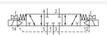

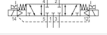

5/3-directional valve, Series CD01-PA

- ISO 15407-1
- 26 mm
- 5/3
- pressurized center exhausted center closed center
- $Q_n = 650$ l/min
- Compressed air connection output base plate DIN ISO 15407-1
- Electrical connection Plug, EN 175301-803, form C
- Manual override with detent without detent



Version	Spool valve, positive overlapping
Sealing principle	Soft sealing
Connection type	Plate connection
Standards	ISO 15407-1, 26 mm
Connector standard	EN 175301-803, form C
Certificates	Free of substances that impair surface wetting in the coating process
Working pressure min./max.	See table below
Control pressure min./max.	See table below
Ambient temperature min./max.	-15 ... 50 °C
Medium temperature min./max.	-15 ... 50 °C
Medium	Compressed air
Max. particle size	50 µm
Oil content of compressed air	0 ... 5 mg/m ³
Nominal flow Q_n	See table below
Compressed air connection	according to ISO 15407-1
Protection class with connection	IP65
Duty cycle	100 %
Typ. switch-on time	See table below
Typ. switch-off time	See table below
Mounting screw	M4 with hexagon socket
Mounting screw tightening torque	2.5 Nm
Weight	0.27 kg

Technical data

Part No.			MO	Operational voltage DC
5763800220		pressurized center		24 V
5763800620		pressurized center		24 V
5763800920		pressurized center	-	24 V
5763805270		pressurized center		-
5763805670		pressurized center		-
5763850220		pressurized center		24 V
5763850620		pressurized center		24 V
5763855270		pressurized center		-
5763855670		pressurized center		-
5763810220		exhausted center		24 V
5763810620		exhausted center		24 V
5763810920		exhausted center	-	24 V
5763815220		exhausted center		-
5763815270		exhausted center		-
5763815670		exhausted center		-
5763815280		exhausted center		-
5763860220		exhausted center		24 V
5763860620		exhausted center		24 V
5763865270		exhausted center		-
5763865670		exhausted center		-
5763820210		closed center		12 V
5763820220		closed center		24 V
5763820620		closed center		24 V
5763825270		closed center		-
5763825670		closed center		-
5763825280		closed center		-
5763870220		closed center		24 V
5763870620		closed center		24 V
5763875270		closed center		-
5763875670		closed center		-

Part No.	Operational voltage AC 50 Hz	Operational voltage AC 60 Hz	Voltage tolerance DC
5763800220	-	-	-10% / +10%
5763800620	-	-	-10% / +10%
5763800920	-	-	-10% / +10%
5763805270	110 V	110 V	-
5763805670	110 V	110 V	-
5763850220	-	-	-10% / +10%
5763850620	-	-	-10% / +10%
5763855270	110 V	110 V	-
5763855670	110 V	110 V	-
5763810220	-	-	-10% / +10%

Part No.	Operational voltage AC 50 Hz	Operational voltage AC 60 Hz	Voltage tolerance DC
5763810620	-	-	-10% / +10%
5763810920	-	-	-10% / +10%
5763815220	24 V	24 V	-
5763815270	110 V	110 V	-
5763815670	110 V	110 V	-
5763815280	230 V	230 V	-
5763860220	-	-	-10% / +10%
5763860620	-	-	-10% / +10%
5763865270	110 V	110 V	-
5763865670	110 V	110 V	-
5763820210	-	-	-10% / +10%
5763820220	-	-	-10% / +10%
5763820620	-	-	-10% / +10%
5763825270	110 V	110 V	-
5763825670	110 V	110 V	-
5763825280	230 V	230 V	-
5763870220	-	-	-10% / +10%
5763870620	-	-	-10% / +10%
5763875270	110 V	110 V	-
5763875670	110 V	110 V	-

Part No.	Voltage tolerance AC 50 Hz	Voltage tolerance AC 60 Hz	Power consumption DC	Holding power AC 50 Hz
5763800220	-	-	1.6 W	-
5763800620	-	-	1.6 W	-
5763800920	-	-	2.06 W	-
5763805270	-10% / +15%	-10% / +15%	-	3 VA
5763805670	-10% / +15%	-10% / +15%	-	3 VA
5763850220	-	-	1.6 W	-
5763850620	-	-	1.6 W	-
5763855270	-10% / +15%	-10% / +15%	-	3 VA
5763855670	-10% / +15%	-10% / +15%	-	3 VA
5763810220	-	-	1.6 W	-
5763810620	-	-	1.6 W	-
5763810920	-	-	2.06 W	-
5763815220	-10% / +15%	-10% / +15%	-	2.2 VA
5763815270	-10% / +15%	-10% / +15%	-	3 VA
5763815670	-10% / +15%	-10% / +15%	-	3 VA
5763815280	-10% / +15%	-10% / +15%	-	2.3 VA
5763860220	-	-	1.6 W	-
5763860620	-	-	1.6 W	-
5763865270	-10% / +15%	-10% / +15%	-	3 VA
5763865670	-10% / +15%	-10% / +15%	-	3 VA
5763820210	-	-	1.6 W	-
5763820220	-	-	1.6 W	-
5763820620	-	-	1.6 W	-
5763825270	-10% / +15%	-10% / +15%	-	3 VA

Part No.	Voltage tolerance AC 50 Hz	Voltage tolerance AC 60 Hz	Power consumption DC	Holding power AC 50 Hz
5763825670	-10% / +15%	-10% / +15%	-	3 VA
5763825280	-10% / +15%	-10% / +15%	-	2.3 VA
5763870220	-	-	1.6 W	-
5763870620	-	-	1.6 W	-
5763875270	-10% / +15%	-10% / +15%	-	3 VA
5763875670	-10% / +15%	-10% / +15%	-	3 VA

Part No.	Holding power AC 60 Hz	Switch-on power AC 50 Hz	Switch-on power AC 60 Hz	Pilot	Nominal flow Qn
5763800220	-	-	-	Internal	-
5763800620	-	-	-	Internal	-
5763800920	-	-	-	Internal	-
5763805270	2.4 VA	4.2 VA	3.4 VA	Internal	-
5763805670	2.4 VA	4.2 VA	3.4 VA	Internal	-
5763850220	-	-	-	External	-
5763850620	-	-	-	External	-
5763855270	2.4 VA	4.2 VA	3.4 VA	External	-
5763855670	2.4 VA	4.2 VA	3.4 VA	External	-
5763810220	-	-	-	Internal	-
5763810620	-	-	-	Internal	-
5763810920	-	-	-	Internal	-
5763815220	1.85 VA	3 VA	2.6 VA	Internal	-
5763815270	2.4 VA	4.2 VA	3.4 VA	Internal	-
5763815670	2.4 VA	4.2 VA	3.4 VA	Internal	-
5763815280	2 VA	3.2 VA	2.8 VA	Internal	-
5763860220	-	-	-	External	-
5763860620	-	-	-	External	-
5763865270	2.4 VA	4.2 VA	3.4 VA	External	-
5763865670	2.4 VA	4.2 VA	3.4 VA	External	-
5763820210	-	-	-	Internal	650 l/min
5763820220	-	-	-	Internal	650 l/min
5763820620	-	-	-	Internal	650 l/min
5763825270	2.4 VA	4.2 VA	3.4 VA	Internal	650 l/min
5763825670	2.4 VA	4.2 VA	3.4 VA	Internal	650 l/min
5763825280	2 VA	3.2 VA	2.8 VA	Internal	650 l/min
5763870220	-	-	-	External	650 l/min
5763870620	-	-	-	External	650 l/min
5763875270	2.4 VA	4.2 VA	3.4 VA	External	650 l/min
5763875670	2.4 VA	4.2 VA	3.4 VA	External	650 l/min

Part No.	Nominal flow 1 ▶ 2	Nominal flow 2 ▶ 3	Working pressure min./max.
5763800220	750 l/min	650 l/min	3 ... 10 bar
5763800620	750 l/min	650 l/min	3 ... 10 bar
5763800920	750 l/min	650 l/min	3 ... 16 bar
5763805270	750 l/min	650 l/min	3 ... 10 bar
5763805670	750 l/min	650 l/min	3 ... 10 bar

Part No.	Nominal flow 1 ▶ 2	Nominal flow 2 ▶ 3	Working pressure min./max.
5763850220	750 l/min	650 l/min	-0.95 ... 16 bar
5763850620	750 l/min	650 l/min	-0.95 ... 16 bar
5763855270	750 l/min	650 l/min	-0.95 ... 16 bar
5763855670	750 l/min	650 l/min	-0.95 ... 16 bar
5763810220	650 l/min	750 l/min	3 ... 10 bar
5763810620	650 l/min	750 l/min	3 ... 10 bar
5763810920	650 l/min	750 l/min	3 ... 16 bar
5763815220	650 l/min	750 l/min	3 ... 10 bar
5763815270	650 l/min	750 l/min	3 ... 10 bar
5763815670	650 l/min	750 l/min	3 ... 10 bar
5763815280	650 l/min	750 l/min	3 ... 10 bar
5763860220	650 l/min	750 l/min	-0.95 ... 16 bar
5763860620	650 l/min	750 l/min	-0.95 ... 16 bar
5763865270	650 l/min	750 l/min	-0.95 ... 16 bar
5763865670	650 l/min	750 l/min	-0.95 ... 16 bar
5763820210	650 l/min	650 l/min	3 ... 10 bar
5763820220	650 l/min	650 l/min	3 ... 10 bar
5763820620	650 l/min	650 l/min	3 ... 10 bar
5763825270	650 l/min	650 l/min	3 ... 10 bar
5763825670	650 l/min	650 l/min	3 ... 10 bar
5763825280	650 l/min	650 l/min	3 ... 10 bar
5763870220	650 l/min	650 l/min	-0.95 ... 16 bar
5763870620	650 l/min	650 l/min	-0.95 ... 16 bar
5763875270	650 l/min	650 l/min	-0.95 ... 16 bar
5763875670	650 l/min	650 l/min	-0.95 ... 16 bar

Part No.	Control pressure min./max.	Typ. switch-on time	Typ. switch-off time
5763800220	3 ... 10 bar	27 ms	55 ms
5763800620	3 ... 10 bar	27 ms	55 ms
5763800920	3 ... 16 bar	27 ms	55 ms
5763805270	3 ... 10 bar	27 ms	55 ms
5763805670	3 ... 10 bar	27 ms	55 ms
5763850220	3 ... 10 bar	27 ms	55 ms
5763850620	3 ... 10 bar	27 ms	55 ms
5763855270	3 ... 10 bar	27 ms	55 ms
5763855670	3 ... 10 bar	27 ms	55 ms
5763810220	3 ... 10 bar	24 ms	58 ms
5763810620	3 ... 10 bar	24 ms	58 ms
5763810920	3 ... 16 bar	24 ms	58 ms
5763815220	3 ... 10 bar	24 ms	58 ms
5763815270	3 ... 10 bar	24 ms	58 ms
5763815670	3 ... 10 bar	24 ms	58 ms
5763815280	3 ... 10 bar	24 ms	58 ms
5763860220	3 ... 10 bar	24 ms	58 ms
5763860620	3 ... 10 bar	24 ms	58 ms
5763865270	3 ... 10 bar	24 ms	58 ms

Part No.	Control pressure min./max.	Typ. switch-on time	Typ. switch-off time
5763865670	3 ... 10 bar	24 ms	58 ms
5763820210	3 ... 10 bar	24 ms	49 ms
5763820220	3 ... 10 bar	24 ms	49 ms
5763820620	3 ... 10 bar	24 ms	49 ms
5763825270	3 ... 10 bar	24 ms	49 ms
5763825670	3 ... 10 bar	24 ms	49 ms
5763825280	3 ... 10 bar	24 ms	49 ms
5763870220	3 ... 10 bar	24 ms	49 ms
5763870620	3 ... 10 bar	24 ms	49 ms
5763875270	3 ... 10 bar	24 ms	49 ms
5763875670	3 ... 10 bar	24 ms	49 ms

Part No.	Electrical connection Pilot valve	Power consumption
5763800220	Plug EN 175301-803, form C	-
5763800620	Plug EN 175301-803, form C	-
5763800920	Plug EN 175301-803, form C	Low power consumption
5763805270	Plug EN 175301-803, form C	-
5763805670	Plug EN 175301-803, form C	-
5763850220	Plug EN 175301-803, form C	-
5763850620	Plug EN 175301-803, form C	-
5763855270	Plug EN 175301-803, form C	-
5763855670	Plug EN 175301-803, form C	-
5763810220	Plug EN 175301-803, form C	-
5763810620	Plug EN 175301-803, form C	-
5763810920	Plug EN 175301-803, form C	Low power consumption
5763815220	Plug EN 175301-803, form C	-
5763815270	Plug EN 175301-803, form C	-
5763815670	Plug EN 175301-803, form C	-
5763815280	Plug EN 175301-803, form C	-
5763860220	Plug EN 175301-803, form C	-
5763860620	Plug EN 175301-803, form C	-
5763865270	Plug EN 175301-803, form C	-
5763865670	Plug EN 175301-803, form C	-
5763820210	Plug EN 175301-803, form C	-
5763820220	Plug EN 175301-803, form C	-
5763820620	Plug EN 175301-803, form C	-
5763825270	Plug EN 175301-803, form C	-
5763825670	Plug EN 175301-803, form C	-
5763825280	Plug EN 175301-803, form C	-
5763870220	Plug EN 175301-803, form C	-
5763870620	Plug EN 175301-803, form C	-
5763875270	Plug EN 175301-803, form C	-
5763875670	Plug EN 175301-803, form C	-

Nominal flow Q_n at 6 bar and $\Delta p = 1$ bar, MO = Manual override

Technical information

The min. control pressure must be adhered to, since otherwise faulty switching and valve failure may result!
The pressure dew point must be at least 15 °C under ambient and medium temperature and may not exceed 3 °C .
The oil content of compressed air must remain constant during the life cycle.
Use only the approved oils from AVENTICS. Further information can be found in the “Technical information” document (available in the MediaCentre).

Versions with voltage of less than 50 V DC do not have a protective ground.

Technical information

Housing	
Polyamide Polyoxymethylene	

Dimensions

Dimensions

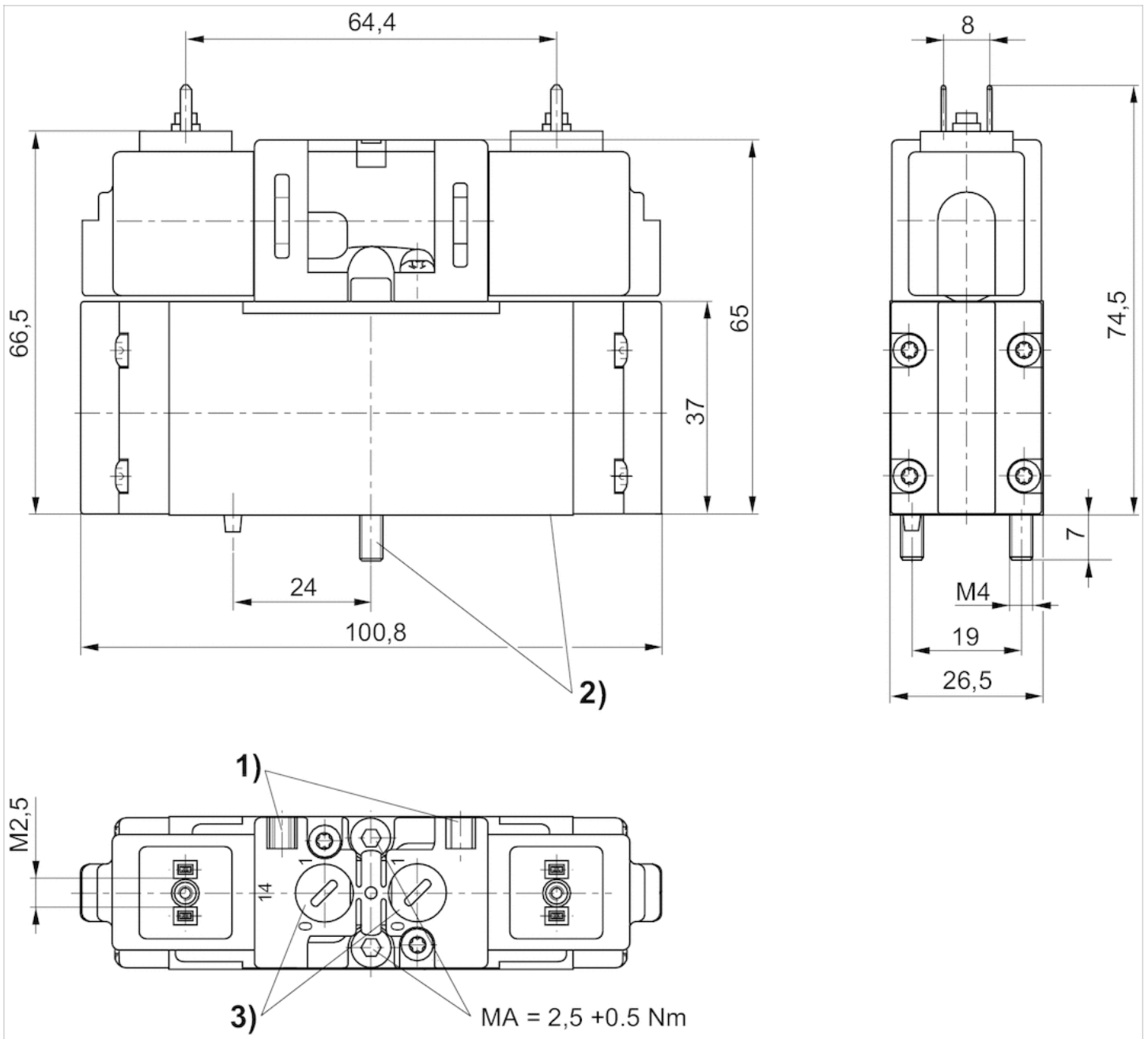

1) mounting space for name plate 2) screws and seals captive 3) manual override

























5/3-directional valve, Series CD01-PA

- ISO 15407-1
- 26 mm
- 5/3
- ISO 15407-1, 26 mm
- pressurized center exhausted center closed center
- $Q_n = 650$ l/min
- Compressed air connection output base plate DIN ISO 15407-1
- Electrical connection Plug, M12x1, 4-pin
- Manual override without detent with detent



Version	Spool valve, positive overlapping
Sealing principle	Soft sealing
Connection type	Plate connection
Standards	ISO 15407-1, 26 mm
Certificates	Free of substances that impair surface wetting in the coating process
Working pressure min./max.	See table below
Control pressure min./max.	3 ... 10 bar
Ambient temperature min./max.	-15 ... 50 °C
Medium temperature min./max.	-15 ... 50 °C
Medium	Compressed air
Max. particle size	50 µm
Oil content of compressed air	0 ... 5 mg/m ³
Nominal flow Q_n	See table below
Compressed air connection	according to ISO 15407-1
Protection class with connection	IP65
Protective circuit	43 V bi-directional
LED status display	Yellow
Duty cycle	100 %
Typ. switch-on time	See table below
Typ. switch-off time	See table below
Mounting screw	M4 with hexagon socket
Mounting screw tightening torque	2.5 Nm
Weight	0.3 kg

Technical data

Part No.			MO	Operational voltage DC
5763800720		pressurized center		24 V
5763800520		pressurized center		24 V
5763850720		pressurized center		24 V
5763850520		pressurized center		24 V
5763810720		exhausted center		24 V
5763810520		exhausted center		24 V
5763860720		exhausted center		24 V
5763860520		exhausted center		24 V
5763820720		closed center		24 V
5763820520		closed center		24 V
5763870720		closed center		24 V
5763870520		closed center		24 V

Part No.	Voltage tolerance DC	Power consumption DC	Pilot	Nominal flow Qn
5763800720	-10% / +10%	1.6 W	Internal	-
5763800520	-10% / +10%	1.6 W	Internal	-
5763850720	-10% / +10%	1.6 W	External	-
5763850520	-10% / +10%	1.6 W	External	-
5763810720	-10% / +10%	1.6 W	Internal	-
5763810520	-10% / +10%	1.6 W	Internal	-
5763860720	-10% / +10%	1.6 W	External	-
5763860520	-10% / +10%	1.6 W	External	-
5763820720	-10% / +10%	1.6 W	Internal	650 l/min
5763820520	-10% / +10%	1.6 W	Internal	650 l/min
5763870720	-10% / +10%	1.6 W	External	650 l/min
5763870520	-10% / +10%	1.6 W	External	650 l/min

Part No.	Nominal flow 1 ▶ 2	Nominal flow 2 ▶ 3	Working pressure min./max.
5763800720	750 l/min	650 l/min	3 ... 10 bar
5763800520	750 l/min	650 l/min	3 ... 10 bar
5763850720	750 l/min	650 l/min	-0.95 ... 16 bar
5763850520	750 l/min	650 l/min	-0.95 ... 16 bar
5763810720	650 l/min	750 l/min	3 ... 10 bar
5763810520	650 l/min	750 l/min	3 ... 10 bar
5763860720	650 l/min	750 l/min	-0.95 ... 16 bar
5763860520	650 l/min	750 l/min	-0.95 ... 16 bar
5763820720	650 l/min	650 l/min	3 ... 10 bar
5763820520	650 l/min	650 l/min	3 ... 10 bar
5763870720	650 l/min	650 l/min	-0.95 ... 16 bar
5763870520	650 l/min	650 l/min	-0.95 ... 16 bar

5763800720	27 ms	55 ms	Plug M12x1 4-pin
5763850720	27 ms	55 ms	Plug M12x1 4-pin
5763810720	24 ms	58 ms	Plug M12x1 4-pin
5763860720	24 ms	58 ms	Plug M12x1 4-pin
5763820720	24 ms	49 ms	Plug M12x1 4-pin
5763870720	24 ms	49 ms	Plug M12x1 4-pin

Nominal flow Qn with secondary pressure 6 bar at $\Delta p = 1$ bar, MO = Manual override

Technical information

The min. control pressure must be adhered to, since otherwise faulty switching and valve failure may result!
 The pressure dew point must be at least 15 °C under ambient and medium temperature and may not exceed 3 °C .
 The oil content of compressed air must remain constant during the life cycle.
 Use only the approved oils from AVENTICS. Further information can be found in the "Technical information" document (available in the MediaCentre).

Technical information

Housing	Polyamide Polyoxymethylene
---------	----------------------------

Dimensions

Dimensions

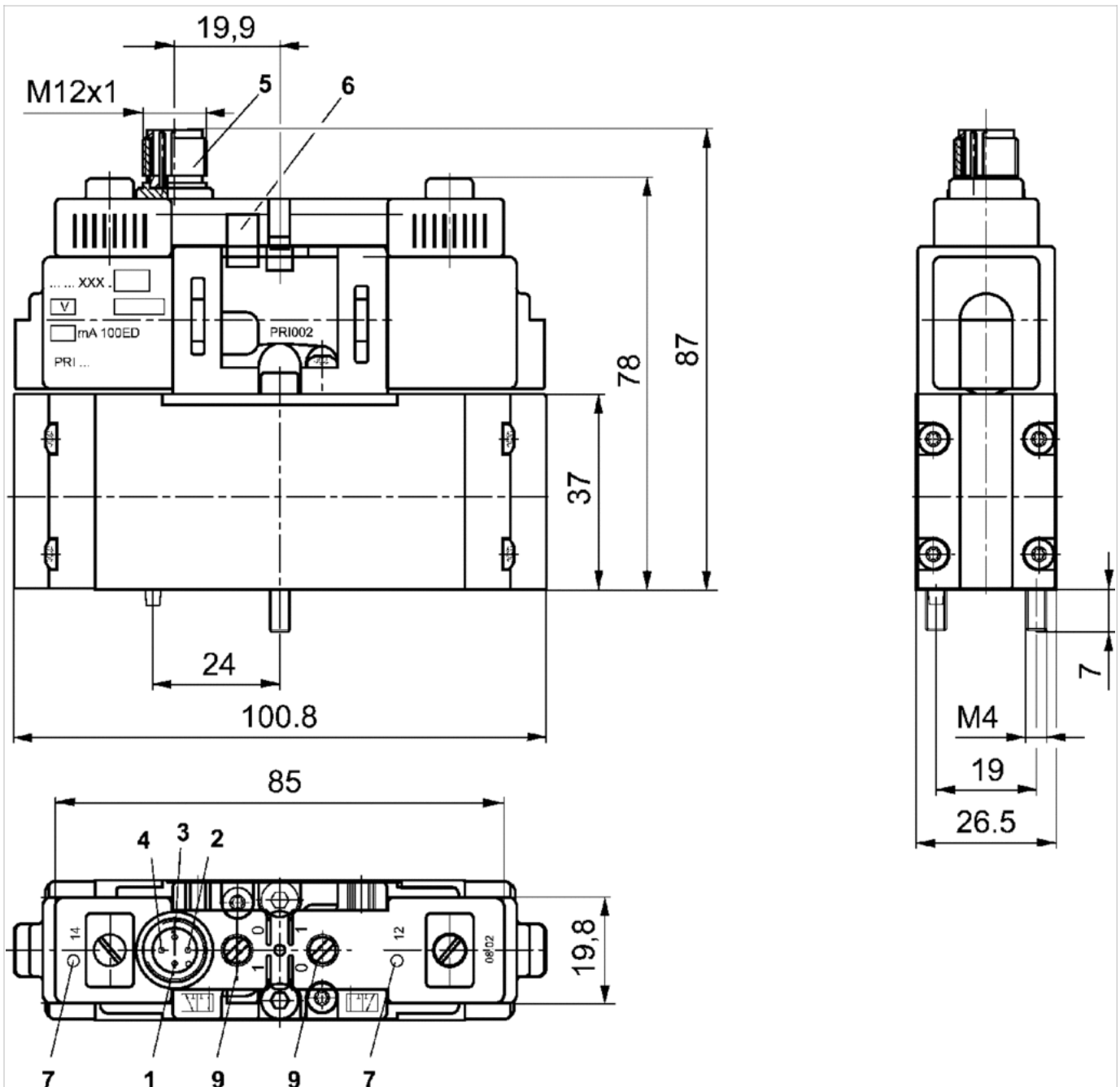

1) not assigned 2) magnet 12 3) 0 V 4) magnet 14 5) metal round plug M12x1 6) positioning pin 7) yellow valve switching state LED 9) manual override

5/2-directional valve, Series CD01-PA

- ISO 15407-1
- 26 mm
- 5/2
- ISO 15407-1, 26 mm
- Electrically and pneumatically operated
- $Q_n = 1010$ l/min
- Manual override with detent

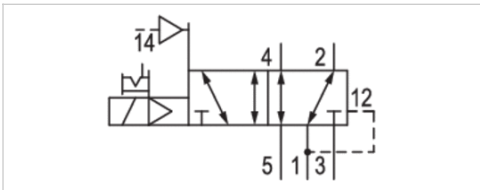

Version	Spool valve, positive overlapping
Pilot	External
Sealing principle	Soft sealing
Connection type	Plate connection
Standards	ISO 15407-1, 26 mm
Certificates	Free of substances that impair surface wetting in the coating process
Working pressure min./max.	-0.95 ... 16 bar
Control pressure min./max.	3 ... 10 bar
Ambient temperature min./max.	-15 ... 50 °C
Medium temperature min./max.	-15 ... 50 °C
Medium	Compressed air
Max. particle size	50 µm
Oil content of compressed air	0 ... 5 mg/m ³
Nominal flow Q_n	1010 l/min
Compressed air connection	according to ISO 15407-1
Protection class with connection	IP65
Duty cycle	100 %
Typ. switch-on time	29 ms
Typ. switch-off time	42 ms
Mounting screw	M4 with hexagon socket
Mounting screw tightening torque	2.5 Nm

Technical data

Part No.	MO	Operational voltage DC	Voltage tolerance DC	Power consumption DC
R412004730		24 V	-10% / +10%	1.6 W

Part No.	Nominal flow 1 ► 2	Nominal flow 2 ► 3
R412004730	1010 l/min	1010 l/min

Nominal flow Q_n at 6 bar and $\Delta p = 1$ bar, MO = Manual override

Technical information

The min. control pressure must be adhered to, since otherwise faulty switching and valve failure may result!
The pressure dew point must be at least 15 °C under ambient and medium temperature and may not exceed 3 °C .
The oil content of compressed air must remain constant during the life cycle.
Use only the approved oils from AVENTICS. Further information can be found in the “Technical information” document (available in the MediaCentre).

Technical information

Housing	Polyamide Polyoxymethylene

Dimensions

Dimensions

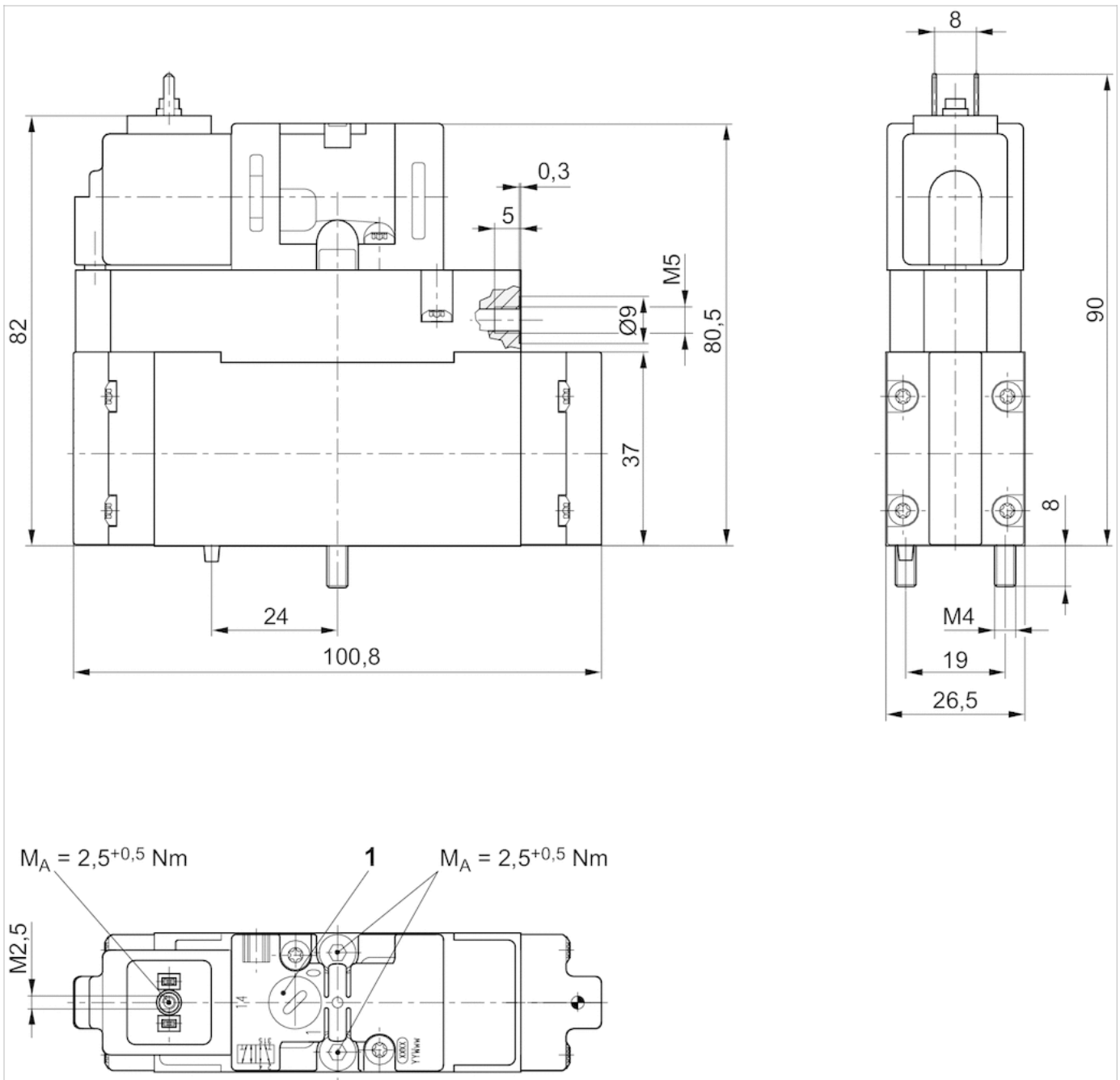

1) Manual override

2x3/2-directional valve, CD01-PA

- Qn = 1010 l/min
- Plate connection
- Compressed air connection output base plate DIN ISO 15407-1
- suitable for ATEX

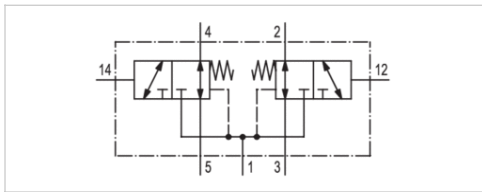
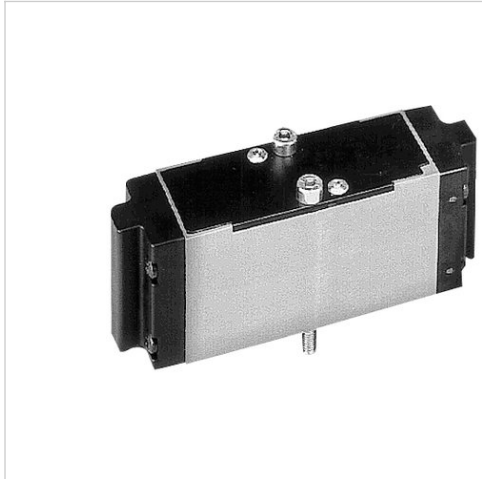

Version	Spool valve, positive overlapping
Sealing principle	Soft sealing
ATEX class G	3G
Certificates	Free of substances that impair surface wetting in the coating process
Connection type	Plate connection
Standards	ISO 15407-1, 26 mm
Nominal flow Qn	1010 l/min
Compressed air connection	base plate DIN ISO 15407-1
Working pressure min./max.	2.5 ... 16 bar
Control pressure min./max.	16 bar
Ambient temperature min./max.	-15 ... 50 °C
Medium temperature min./max.	-15 ... 50 °C
Medium	Compressed air class 3-3-2
Max. particle size	50 µm
Oil content of compressed air	0 ... 5 mg/m ³
Mounting screw	M4 with hexagon socket
Mounting screw tightening torque	2.5 Nm
Weight	0.16 kg

Technical data

Part No.	NC/NC	Flow	Flow	ATEX
		Qn 1→2	Qn 2→3	
5714003990	NC/NC	1010 l/min	1010 l/min	suitable for ATEX

Nominal flow Qn at 6 bar and $\Delta p = 1$ bar

Technical information

The min. control pressure must be adhered to, since otherwise faulty switching and valve failure may result!
 The pressure dew point must be at least 15 °C under ambient and medium temperature and may not exceed 3 °C .
 The oil content of compressed air must remain constant during the life cycle.
 Use only the approved oils from AVENTICS. Further information can be found in the "Technical information" document (available in the MediaCentre).

Technical information

Housing	Polyamide Polyoxymethylene
Seals	Acrylonitrile butadiene rubber

Dimensions

Dimensions

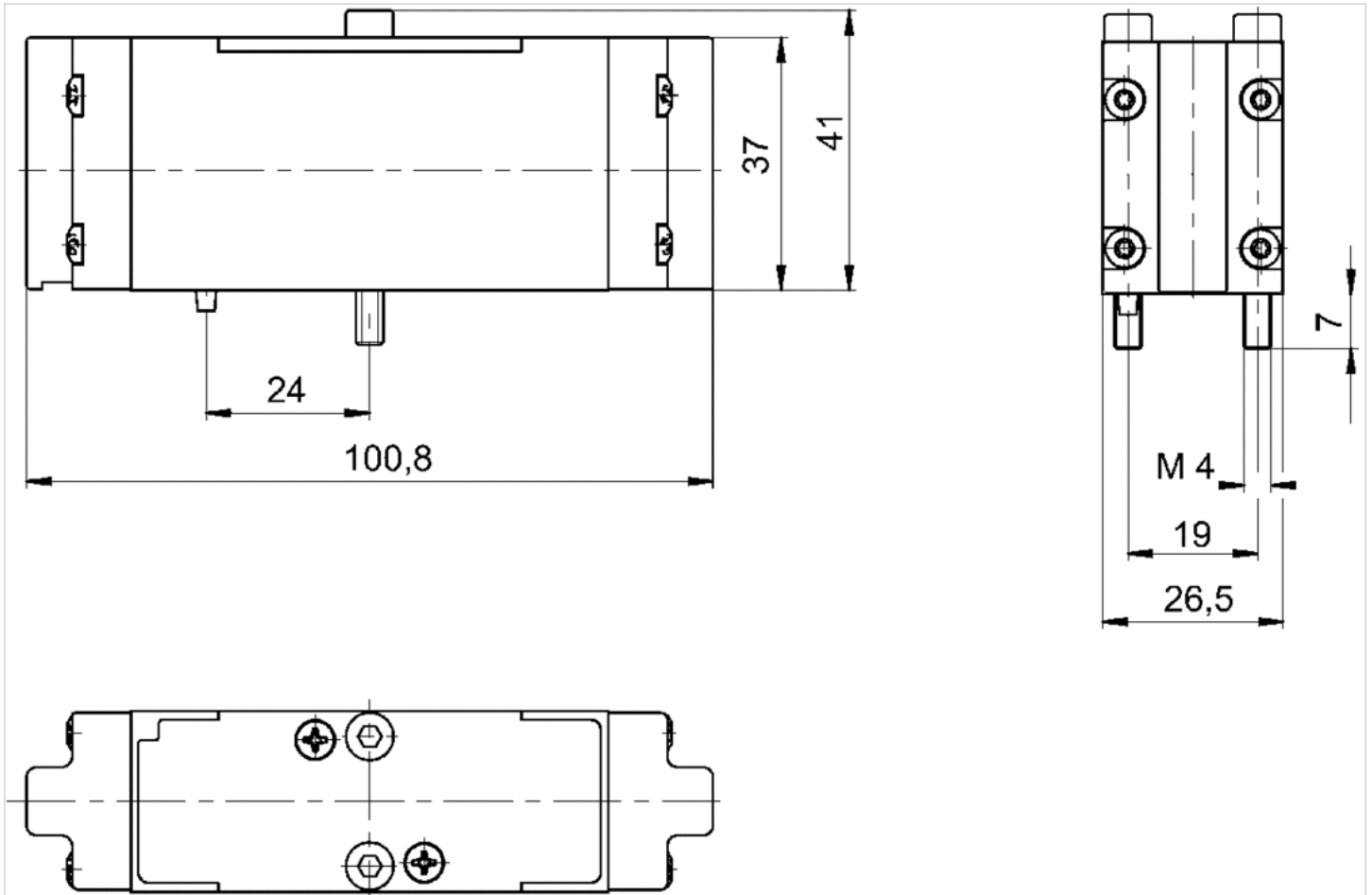

Diagrams

Diagram, Control pressure

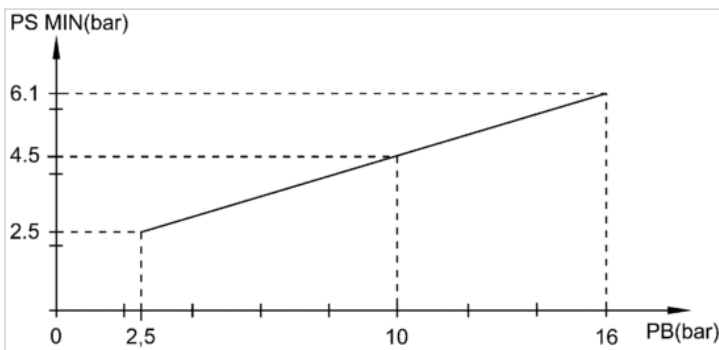

PB= Working pressure
PS = control pressure

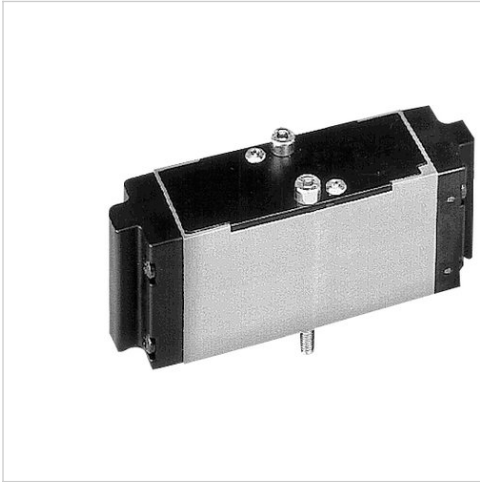

5/2-directional valve, CD01-PA

- Qn = 1010 l/min
- Plate connection
- Compressed air connection output base plate DIN ISO 15407-1
- suitable for ATEX



Version	Spool valve, positive overlapping
Sealing principle	Soft sealing
ATEX class G	3G
Certificates	Free of substances that impair surface wetting in the coating process
Connection type	Plate connection
Standards	ISO 15407-1, 26 mm
Nominal flow Qn	1010 l/min
Compressed air connection	base plate DIN ISO 15407-1
Working pressure min./max.	-0.95 ... 16 bar
Control pressure min./max.	See table below
Ambient temperature min./max.	See table below
Medium temperature min./max.	See table below
Medium	Compressed air class 3-3-2
Max. particle size	50 µm
Oil content of compressed air	0 ... 5 mg/m ³
Mounting screw	M4 with hexagon socket
Mounting screw tightening torque	2.5 Nm
Weight	0.16 kg

Technical data

Part No.		Flow	Flow	Control pressure min./max.	Ambient temperature min./max.
		Qn 1►2	Qn 2►3		
5714003500		1010 l/min	1010 l/min	16 bar	-15 ... 50 °C
5714003520		1010 l/min	1010 l/min	2 ... 16 bar	-15 ... 50 °C
5714003530		1010 l/min	1010 l/min	2 ... 16 bar	0 ... 50 °C

Part No.	Medium temperature min./max.	ATEX	
5714003500	-15 ... 50 °C	suitable for ATEX	1)
5714003520	-15 ... 50 °C	suitable for ATEX	-
5714003530	0 ... 50 °C	suitable for ATEX	2)

Nominal flow Qn at 6 bar and $\Delta p = 1$ bar

- 1) See diagram, With differential piston, Signal 14 has priority
- 2) With differential piston, Signal 14 has priority

Technical information

The min. control pressure must be adhered to, since otherwise faulty switching and valve failure may result!
 The pressure dew point must be at least 15 °C under ambient and medium temperature and may not exceed 3 °C .
 The oil content of compressed air must remain constant during the life cycle.
 Use only the approved oils from AVENTICS. Further information can be found in the "Technical information" document (available in the MediaCentre).

Technical information

Housing

Polyamide Polyoxymethylene

Dimensions

Dimensions

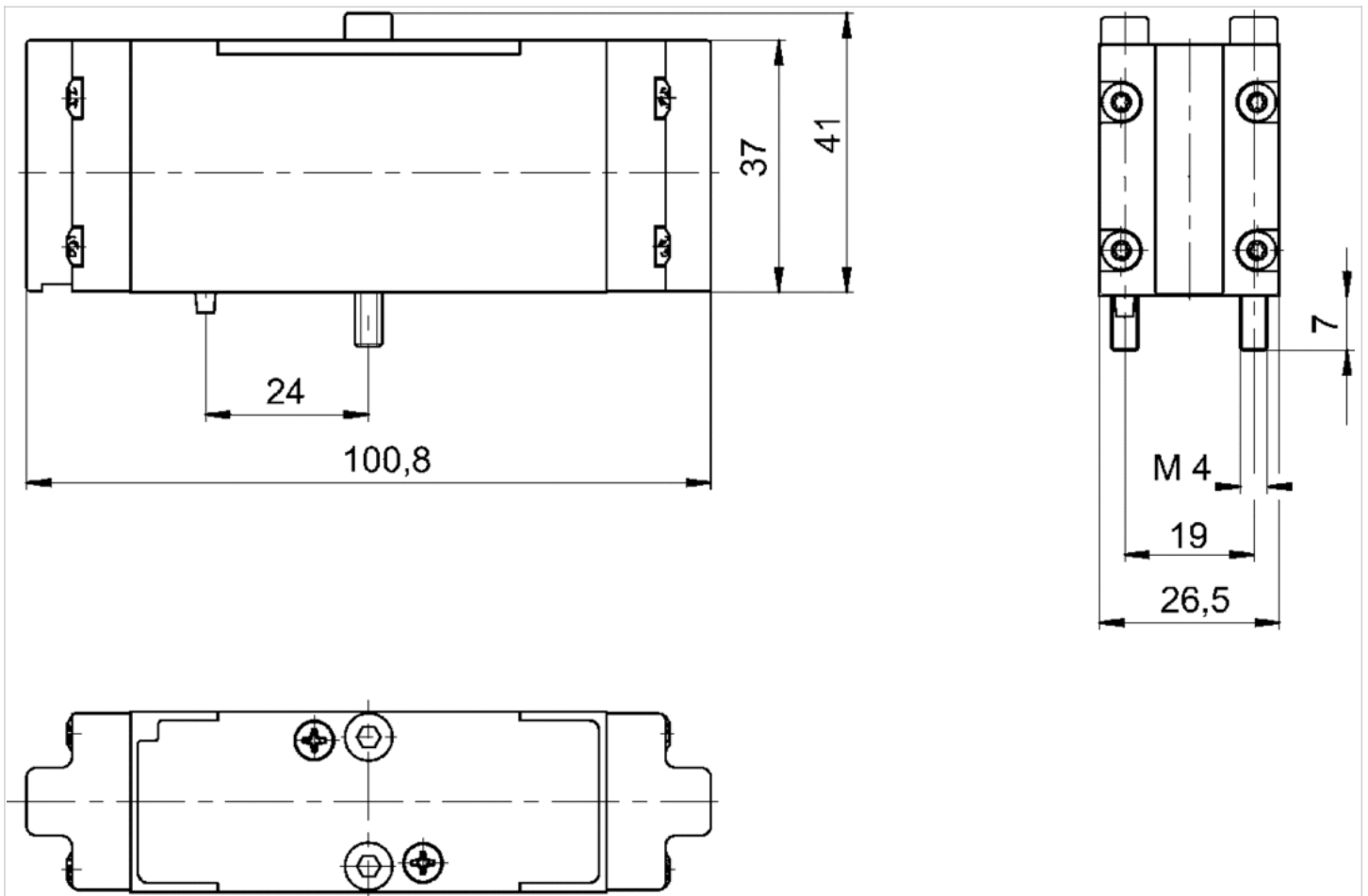

Diagrams

Diagram, Control pressure

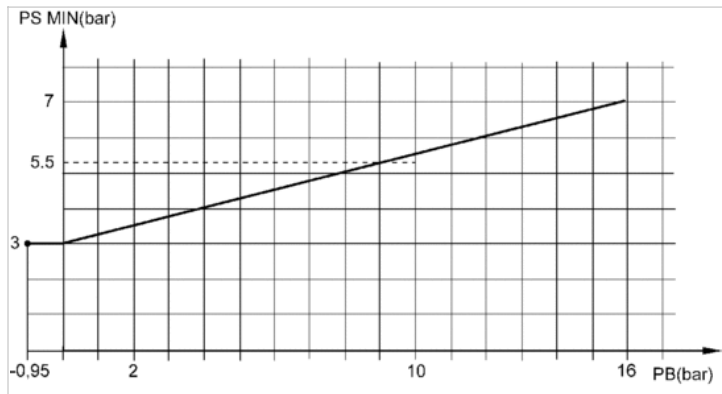

PB= Working pressure
PS = control pressure

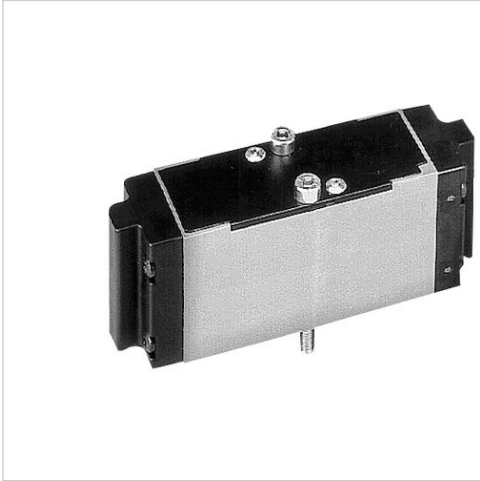

5/3-directional valve, CD01-PA

- ISO 15407-1, 26 mm
- $Q_n = 650$ l/min
- Plate connection
- Compressed air connection output base plate DIN ISO 15407-1
- suitable for ATEX



Version	Spool valve, positive overlapping
Sealing principle	Soft sealing
ATEX class G	3G
Certificates	Free of substances that impair surface wetting in the coating process
Connection type	Plate connection
Standards	ISO 15407-1, 26 mm
Compressed air connection	base plate DIN ISO 15407-1
Working pressure min./max.	-0.95 ... 16 bar
Control pressure min./max.	3 ... 16 bar
Ambient temperature min./max.	-15 ... 50 °C
Medium temperature min./max.	-15 ... 50 °C
Medium	Compressed air class 3-3-2
Max. particle size	50 µm
Oil content of compressed air	0 ... 5 mg/m ³
Mounting screw	M4 with hexagon socket
Mounting screw tightening torque	2.5 Nm
Weight	0.16 kg

Technical data

Part No.			Flow	Flow	Flow	ATEX
			Q_n	$Q_n 1 \rightarrow 2$	$Q_n 2 \rightarrow 3$	
5714003810		exhausted center	-	650 l/min	750 l/min	suitable for ATEX
5714003800		pressurized center	-	750 l/min	650 l/min	suitable for ATEX
5714003820		closed center	650 l/min	650 l/min	650 l/min	suitable for ATEX

Nominal flow Q_n at 6 bar and $\Delta p = 1$ bar

Technical information

The min. control pressure must be adhered to, since otherwise faulty switching and valve failure may result!
 The pressure dew point must be at least 15 °C under ambient and medium temperature and may not exceed 3 °C .
 The oil content of compressed air must remain constant during the life cycle.
 Use only the approved oils from AVENTICS. Further information can be found in the "Technical information" document (available in the MediaCentre).

Technical information

Housing	Polyamide Polyoxymethylene
Seals	Acrylonitrile butadiene rubber

Dimensions

Dimensions

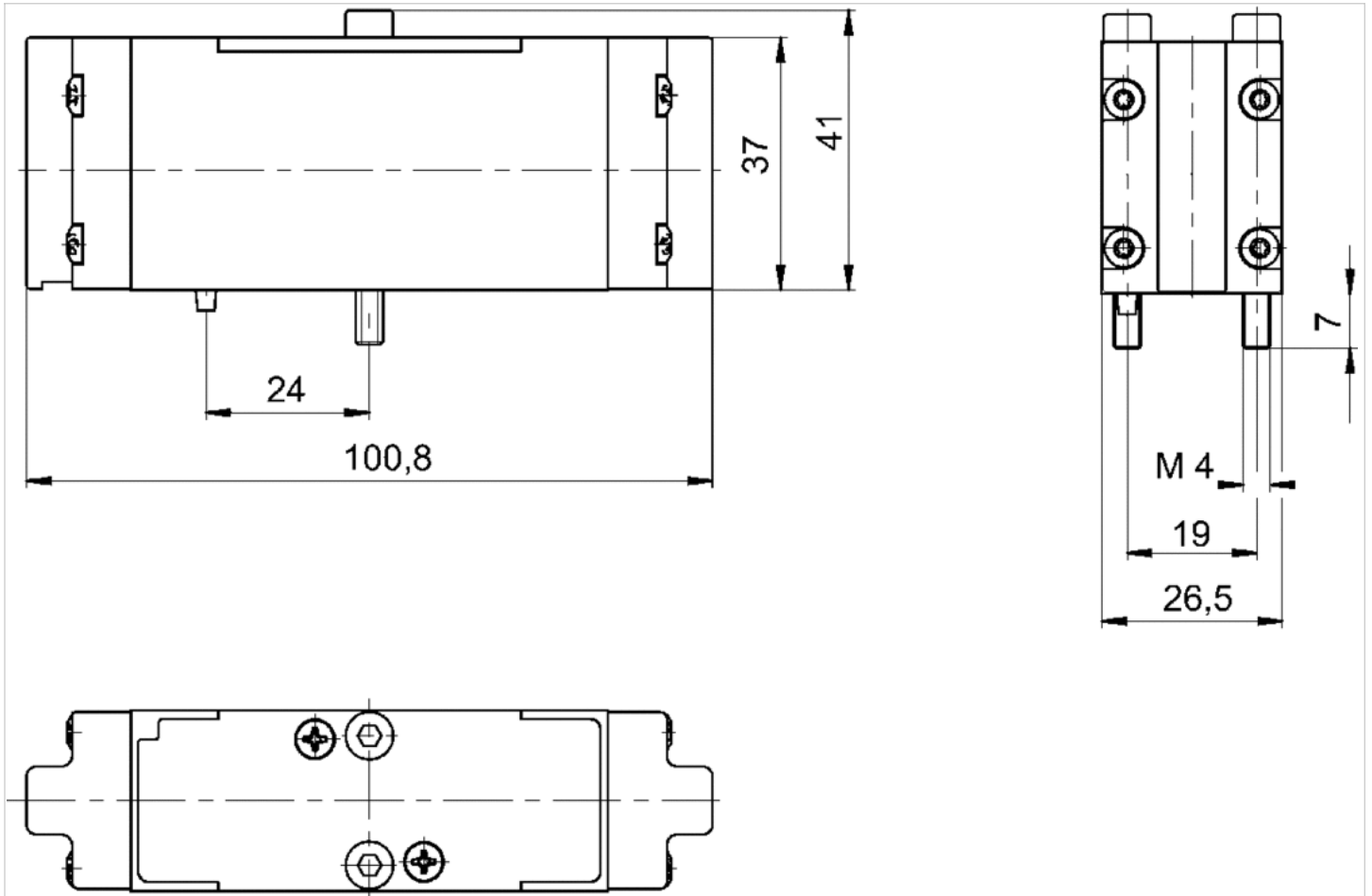

Single subbase, ports on side

- standard ISO 15407-1
- Frame size 26 mm
- Compressed air connection output $\varnothing 6 \times 1$ $\varnothing 8 \times 1$
- Reversed pressure supply permissible
- With collective pilot air exhaust



Standards	ISO 15407-1
Compressed air connection	according to ISO 15407-1
Working pressure min./max.	-0.95 ... 16 bar
Ambient temperature min./max.	-25 ... 70 °C
Medium temperature min./max.	-25 ... 70 °C
Medium	Compressed air
Number of valve positions max.	1
Direction of pneumatic port (1)	On the side
Direction of pneumatic port (3,5)	On the side
Direction of pneumatic port (2,4)	On the side
Direction of pneumatic port (12)	On the side
Direction of pneumatic port (14)	On the side
Exhaust (3,5)	With directional exhaust (3/5)
Exhaust type	Ports separated
Weight	0.074 kg

Technical data

Part No.	Compressed air connection Input [1]	Compressed air connection Output [2 / 4]
8985121372	$\varnothing 6 \times 1$	$\varnothing 6 \times 1$
8985121382	$\varnothing 8 \times 1$	$\varnothing 8 \times 1$

Part No.	Compressed air connection Exhaust [3 / 5]	Compressed air connection Pilot connection [X]
8985121372	G 1/8	$\varnothing 4$
8985121382	G 1/8	$\varnothing 4$

Part No.	Compressed air connection Pilot control exhaust [R]
8985121372	$\varnothing 4$
8985121382	$\varnothing 4$

Technical information

The min. control pressure must be adhered to, since otherwise faulty switching and valve failure may result!
 The pressure dew point must be at least 15 °C under ambient and medium temperature and may not exceed 3 °C .
 The oil content of compressed air must remain constant during the life cycle.
 Use only the approved oils from AVENTICS. Further information can be found in the "Technical information" document (available in the MediaCentre).

Technical information

Base plate	Polyamide fiber-glass reinforced
------------	----------------------------------

Dimensions

Dimensions

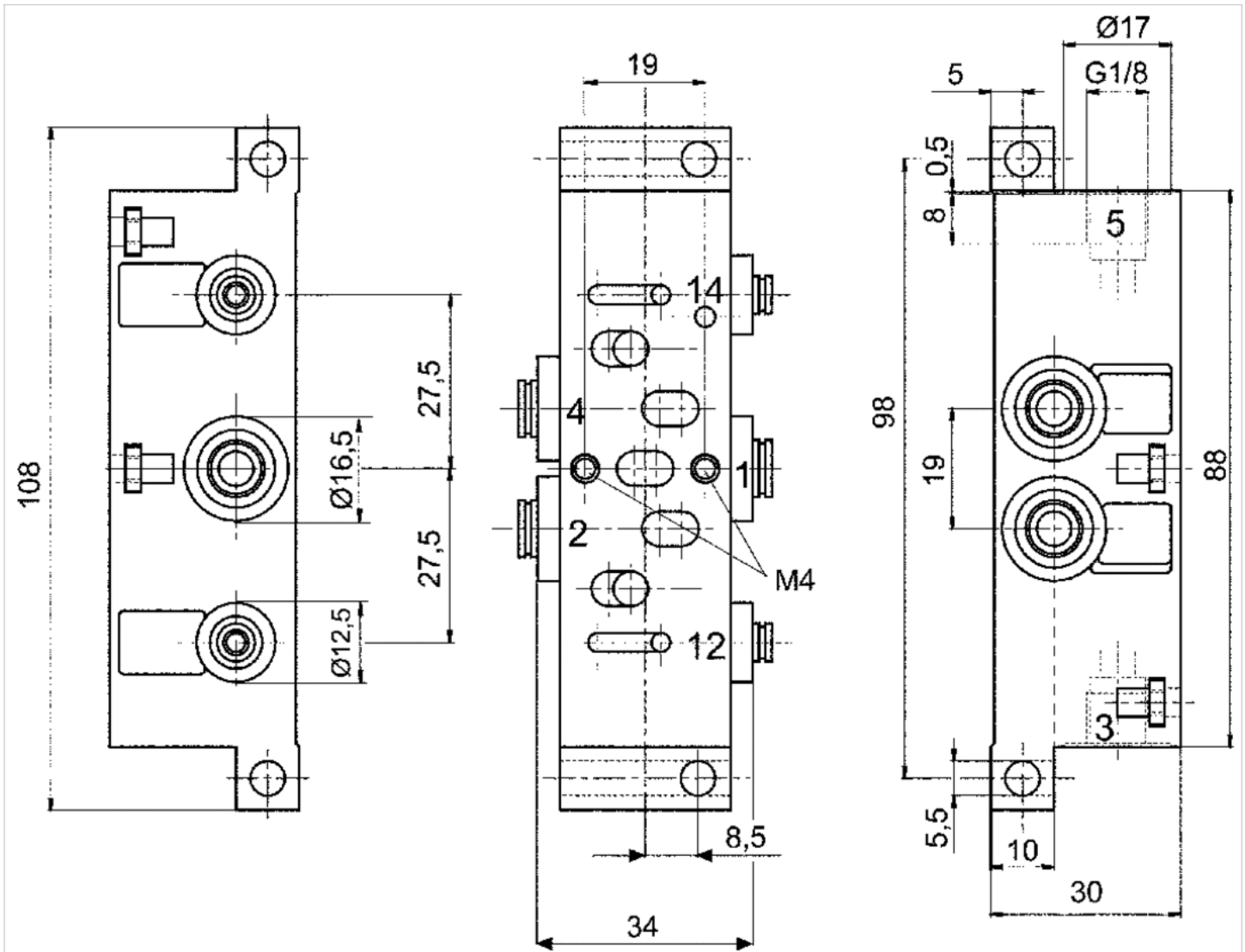

Single subbase, ports on bottom

- standard ISO 15407-1
- Frame size 26 mm
- Compressed air connection output Ø 8x1
- Reversed pressure supply permissible
- With collective pilot air exhaust



Standards	ISO 15407-1
Compressed air connection	according to ISO 15407-1
Working pressure min./max.	-0.95 ... 16 bar
Ambient temperature min./max.	-25 ... 70 °C
Medium temperature min./max.	-25 ... 70 °C
Medium	Compressed air
Number of valve positions max.	1
Direction of pneumatic port (1)	Down
Direction of pneumatic port (3,5)	On the side
Direction of pneumatic port (2,4)	Down
Direction of pneumatic port (12)	Down
Direction of pneumatic port (14)	Down
Exhaust (3,5)	With directional exhaust (3/5)
Exhaust type	Ports separated
Weight	0.074 kg

Technical data

Part No.	Compressed air connection Input [1]	Compressed air connection Output [2 / 4]
8985121392	Ø 8x1	Ø 8x1

Part No.	Compressed air connection Exhaust [3 / 5]	Compressed air connection Pilot connection [X]
8985121392	G 1/8	Ø 4

Part No.	Compressed air connection Pilot control exhaust [R]
8985121392	Ø 4

Technical information

The min. control pressure must be adhered to, since otherwise faulty switching and valve failure may result!
 The pressure dew point must be at least 15 °C under ambient and medium temperature and may not exceed 3 °C .
 The oil content of compressed air must remain constant during the life cycle.
 Use only the approved oils from AVENTICS. Further information can be found in the "Technical information" document (available in the MediaCentre).

Technical information

Base plate	Polyamide fiber-glass reinforced
------------	----------------------------------

Dimensions

Dimensions

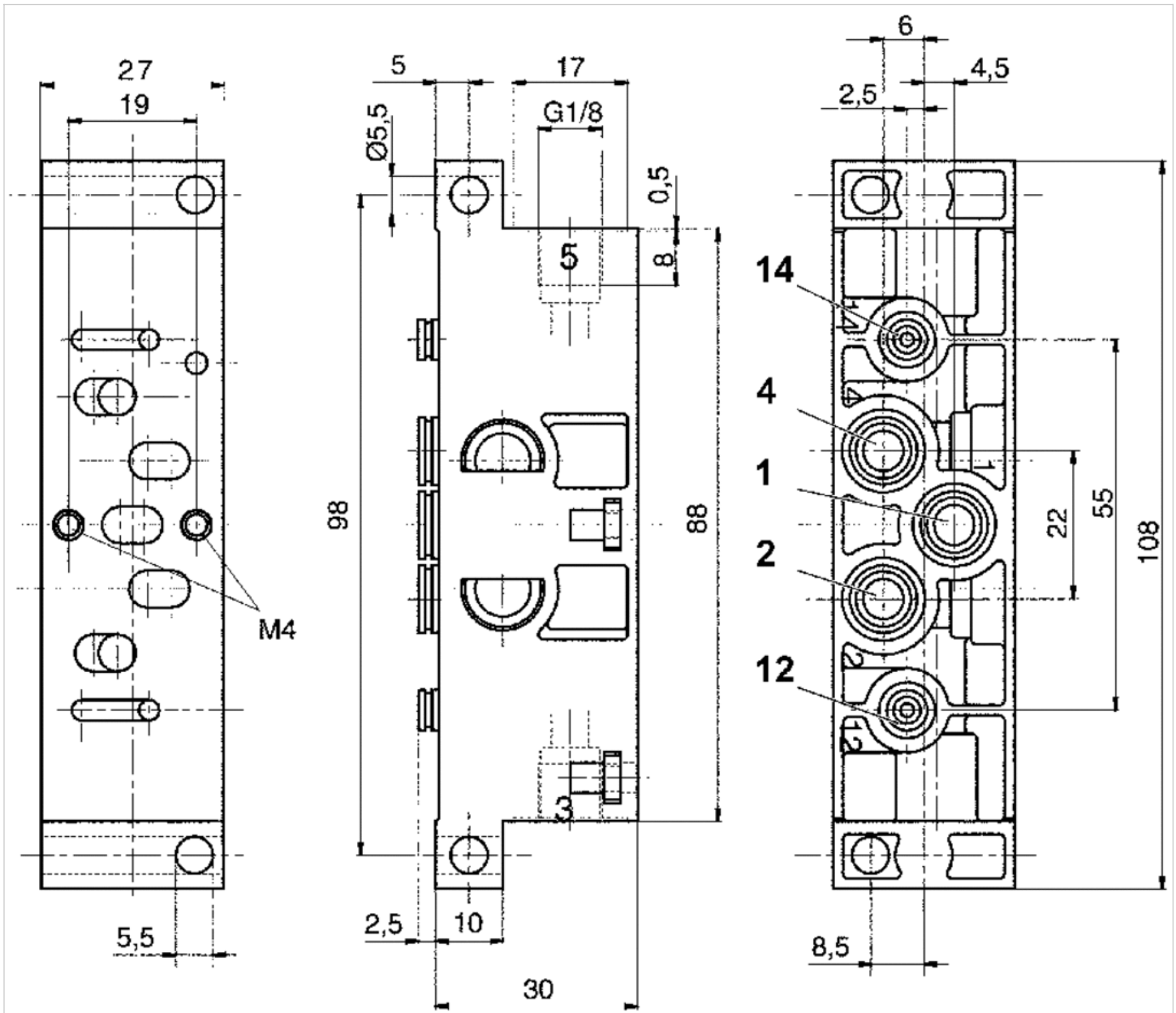

Base plate

- standard ISO 15407-1
- Frame size 26 mm
- type A
- Compressed air connection output G 1/4 Ø 10x1
- Can be assembled into blocks
- Single base plate principle
- Reversed pressure supply permissible
- With collective pilot air exhaust



Standards	ISO 15407-1
Compressed air connection	according to ISO 15407-1
Working pressure min./max.	-0.95 ... 16 bar
Ambient temperature min./max.	-15 ... 70 °C
Medium temperature min./max.	-15 ... 70 °C
Medium	Compressed air
Number of valve positions max.	1
Grid dimension	27.1 mm
Exhaust (3,5)	With directional exhaust (3/5)
Exhaust type	Ports separated
Mounting screw	with hexagon socket
Tightening torque for mounting screws	4 Nm
Weight	0.195 kg

Technical data

Part No.	Type	Compressed air connection Output [2 / 4]	Compressed air connection Pilot connection [X]
1825504023	C1	G 1/4	-
1825504025	C1	Ø 10x1	-
1825504026	C2	G 1/4	M5
1825504029	C3	G 1/4	-
1825504030	C4	G 1/4	M5

Part No.	Compressed air connection Pilot control exhaust [R]	Connection direction
1825504023	-	On the side
1825504025	-	On the side
1825504026	M5	On the side
1825504029	-	Down
1825504030	M5	Down

Scope of delivery incl. seal and mounting screws

Technical information

The min. control pressure must be adhered to, since otherwise faulty switching and valve failure may result!
 The pressure dew point must be at least 15 °C under ambient and medium temperature and may not exceed 3 °C .
 The oil content of compressed air must remain constant during the life cycle.
 Use only the approved oils from AVENTICS. Further information can be found in the “Technical information” document (available in the MediaCentre).

Technical information

Base plate	Die-cast aluminum
------------	-------------------

Dimensions

Overview drawing

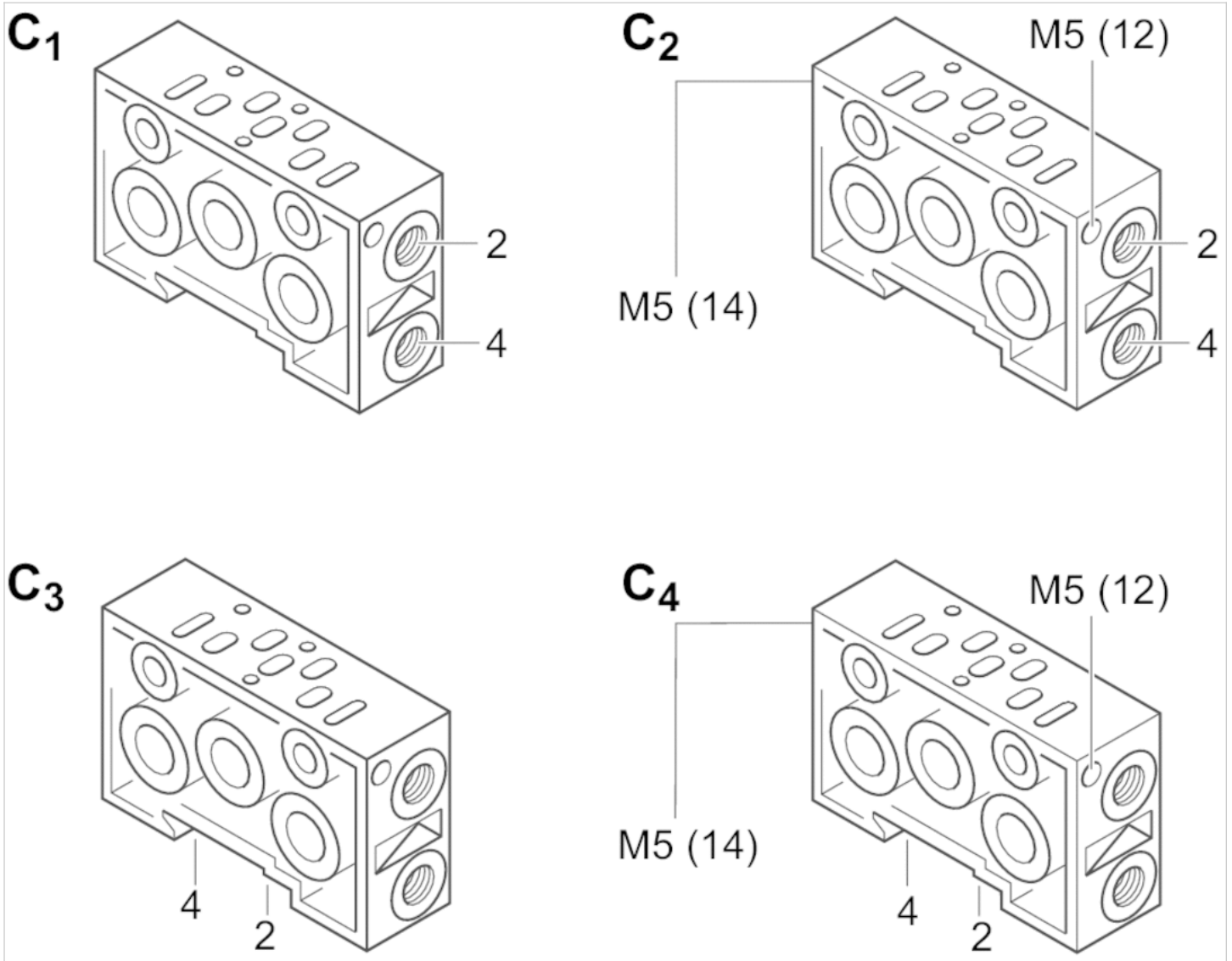

Dimensions

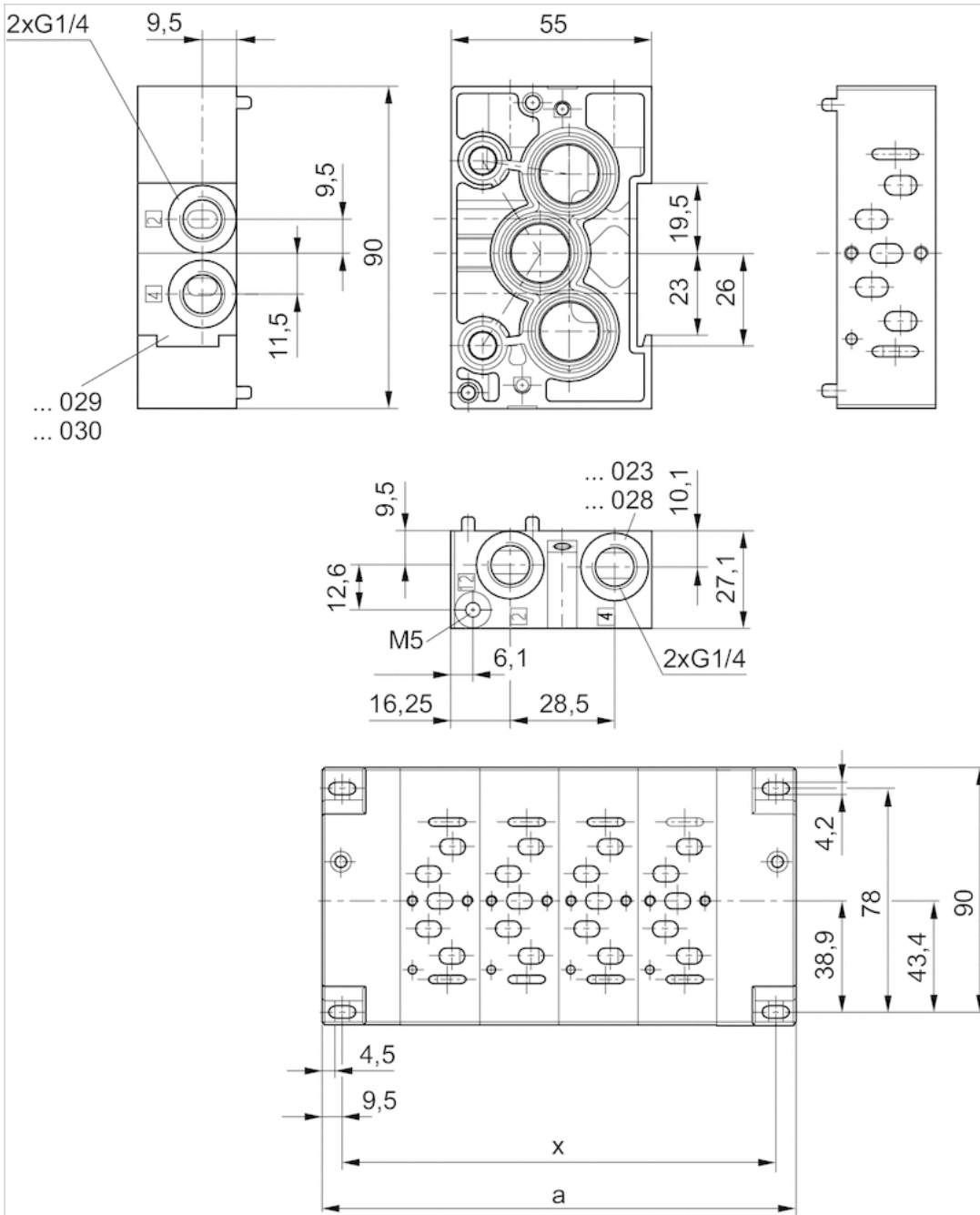

End plate left, End plate right

- standard ISO 15407-1
- Frame size 26 mm
- type A
- Can be assembled into blocks
- Base plate principle, multiple
- Reversed pressure supply permissible
- With collective pilot air exhaust



Standards	ISO 15407-1
Working pressure min./max.	-0.95 ... 16 bar
Ambient temperature min./max.	-15 ... 70 °C
Medium temperature min./max.	-15 ... 70 °C
Medium	Compressed air
Grid dimension	27.1 mm
Direction of pneumatic port (1)	On the side
Direction of pneumatic port (3,5)	On the side
Direction of pneumatic port (12)	On the side
Direction of pneumatic port (14)	On the side
Exhaust (3,5)	With directional exhaust (3/5)
Exhaust type	Ports separated
Mounting screw	with hexagon socket
Tightening torque for mounting screws	4 Nm

Technical data

Part No.	Compressed air connection Input [1]	Compressed air connection Exhaust [3 / 5]
1825504031	G 3/8	G 3/8

Part No.	Compressed air connection Pilot connection [X]	Compressed air connection Pilot control exhaust [R]
1825504031	G 1/8	G 1/8

Scope of delivery: end plate kit incl. seal and mounting screws

Technical information

The min. control pressure must be adhered to, since otherwise faulty switching and valve failure may result!
 The pressure dew point must be at least 15 °C under ambient and medium temperature and may not exceed 3 °C .
 The oil content of compressed air must remain constant during the life cycle.
 Use only the approved oils from AVENTICS. Further information can be found in the "Technical information" document (available in the MediaCentre).

Technical information

Material	
Base plate	Die-cast aluminum
Seal	Acrylonitrile butadiene rubber

Dimensions

Dimensions

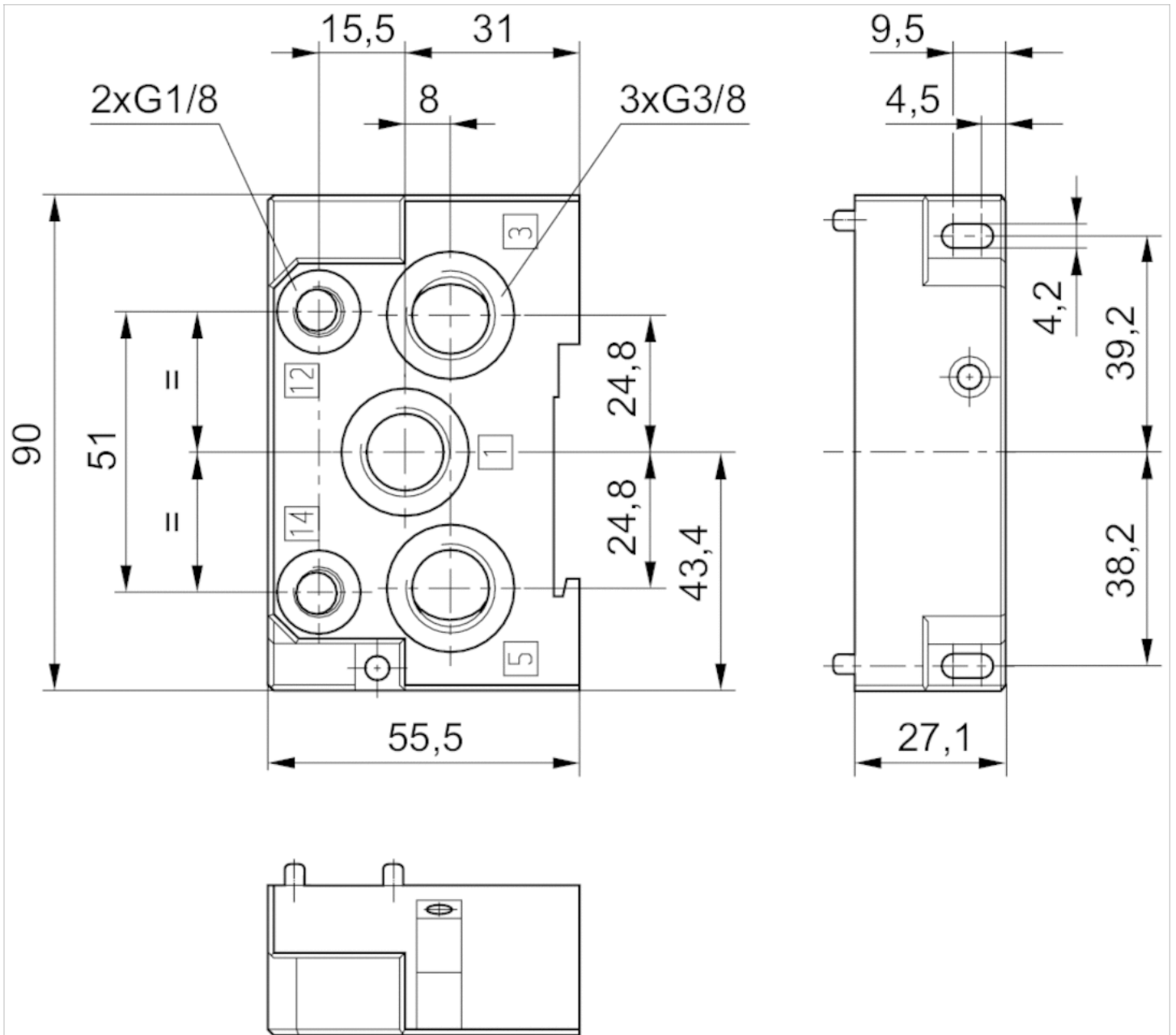

End plate left, End plate right

- standard ISO 15407-1
- Frame size 26 mm
- type B
- Can be assembled into blocks
- Base plate principle, multiple
- Reversed pressure supply permissible
- I/O extension possible
- With collective pilot air exhaust



Standards	ISO 15407-1
Working pressure min./max.	-0.95 ... 16 bar
Ambient temperature min./max.	-25 ... 70 °C
Medium temperature min./max.	-25 ... 70 °C
Medium	Compressed air
Grid dimension	22 mm
Direction of pneumatic port (1)	On the side
Direction of pneumatic port (3,5)	On the side
Direction of pneumatic port (R)	On the side
Direction of pneumatic port (X)	On the side
Exhaust (3,5)	With directional exhaust (3/5)
Exhaust type	Ports separated
Tightening torque for mounting screws	4 Nm
Weight	See table below

Technical data

Part No.	Compressed air connection Input [1]	Compressed air connection Exhaust [3 / 5]	Pilot control exhaust
8985121002	G 3/8	G 3/8	G 1/8
8985121012	G 3/8	G 3/8	G 1/8

Part No.	Pilot connection	Weight	
8985121002	G 1/8	0.147 kg	1)
8985121012	G 1/8	0.15 kg	2)

- 1) End plate left
2) End plate right

Technical information

The min. control pressure must be adhered to, since otherwise faulty switching and valve failure may result!
The pressure dew point must be at least 15 °C under ambient and medium temperature and may not exceed 3 °C .
The oil content of compressed air must remain constant during the life cycle.
Use only the approved oils from AVENTICS. Further information can be found in the "Technical information" document (available in the MediaCentre).

I/O functionality by combining with contact bridge kit for additional inputs/outputs

Technical information

Base plate	Die-cast aluminum
------------	-------------------

Dimensions

Dimensions

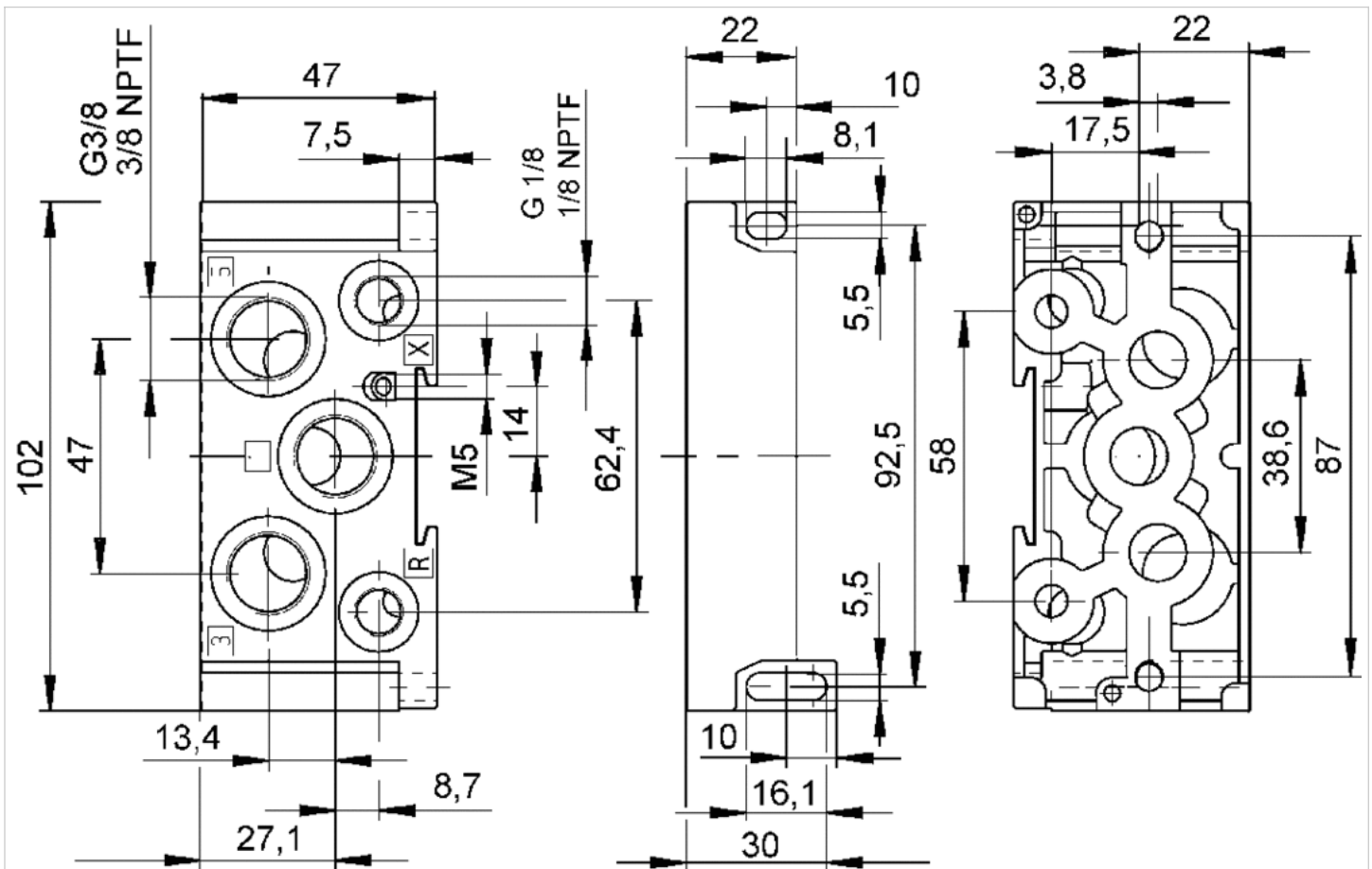

Base plate, ports 2 and 4 on side

- standard ISO 15407-1
- Frame size 26 mm
- type B
- Compressed air connection output $\varnothing 4$ $\varnothing 6 \times 1$ $\varnothing 8 \times 1$ G 1/8
- Can be assembled into blocks
- Single base plate principle
- Reversed pressure supply permissible

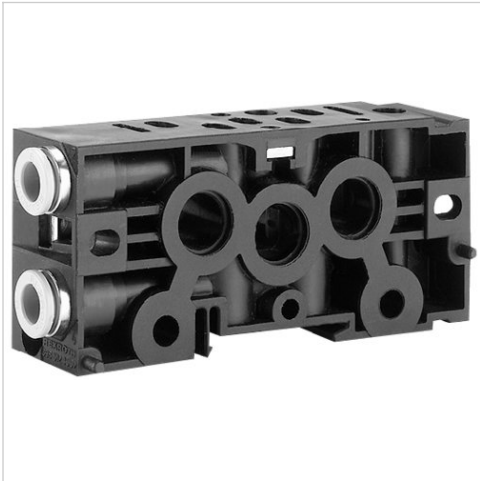

Standards	ISO 15407-1
Compressed air connection	according to ISO 15407-1
Working pressure min./max.	-0.95 ... 16 bar
Ambient temperature min./max.	-25 ... 70 °C
Medium temperature min./max.	-25 ... 70 °C
Medium	Compressed air
Number of valve positions max.	1
Grid dimension	27 mm
Direction of pneumatic port (3,5)	On the side
Direction of pneumatic port (2,4)	On the side
Exhaust (3,5)	With directional exhaust (3/5)
Exhaust type	Ports separated
Mounting screw	with hexagon socket
Tightening torque for mounting screws	4 Nm
Weight	See table below

Technical data

Part No.	Compressed air connection Output [2 / 4]	Weight
8985121162	$\varnothing 4$	-
8985121122	$\varnothing 6 \times 1$	0.13 kg
8985121052	$\varnothing 8 \times 1$	-
8985121092	G 1/8	-

Scope of delivery incl. seal and mounting screws

Technical information

The min. control pressure must be adhered to, since otherwise faulty switching and valve failure may result!

The pressure dew point must be at least 15 °C under ambient and medium temperature and may not exceed 3 °C .

The oil content of compressed air must remain constant during the life cycle.

Use only the approved oils from AVENTICS. Further information can be found in the "Technical information" document (available in the MediaCentre).

Base plate, ports 2 and 4 on bottom

- standard ISO 15407-1
- Frame size 26 mm
- type B
- Compressed air connection output $\varnothing 6 \times 1$ $\varnothing 8 \times 1$ G 1/8
- Can be assembled into blocks
- Single base plate principle
- Reversed pressure supply permissible
- With collective pilot air exhaust



Standards	ISO 15407-1
Compressed air connection	according to ISO 15407-1
Working pressure min./max.	-0.95 ... 16 bar
Ambient temperature min./max.	-25 ... 70 °C
Medium temperature min./max.	-25 ... 70 °C
Medium	Compressed air
Number of valve positions max.	1
Grid dimension	27 mm
Direction of pneumatic port (2,4)	Down
Exhaust (3,5)	With directional exhaust (3/5)
Exhaust type	Ports separated
Mounting screw	with hexagon socket
Tightening torque for mounting screws	4 Nm

Technical data

Part No.	Compressed air connection Output [2 / 4]
8985121102	$\varnothing 6 \times 1$
8985121032	$\varnothing 8 \times 1$
8985121072	G 1/8

Scope of delivery incl. seal and mounting screws

Technical information

The min. control pressure must be adhered to, since otherwise faulty switching and valve failure may result!
 The pressure dew point must be at least 15 °C under ambient and medium temperature and may not exceed 3 °C .
 The oil content of compressed air must remain constant during the life cycle.
 Use only the approved oils from AVENTICS. Further information can be found in the "Technical information" document (available in the MediaCentre).

Technical information

Material	
Base plate	Polyamide fiber-glass reinforced
Seal	Acrylonitrile butadiene rubber

Dimensions

Dimensions

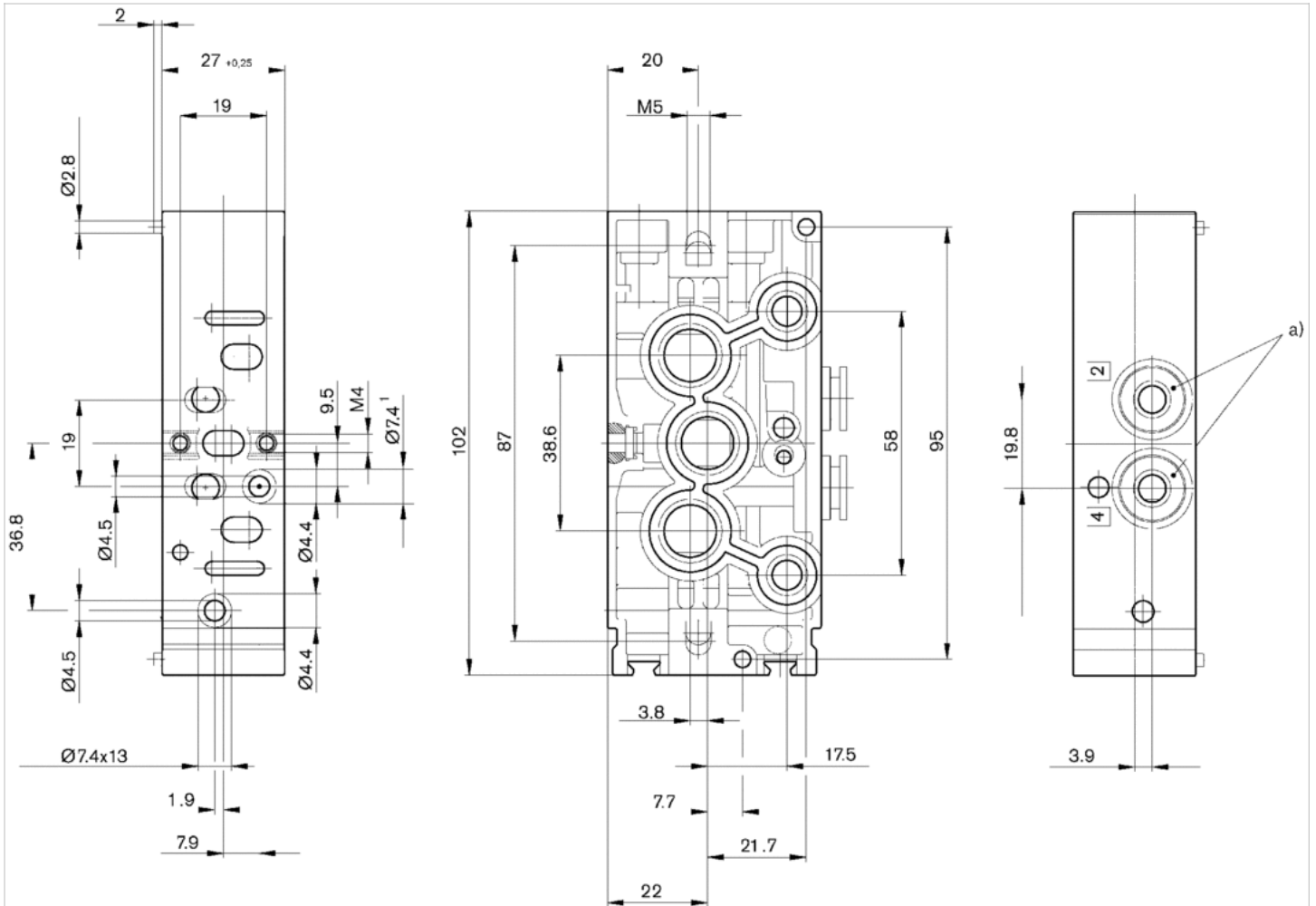

a) push-in fitting or thread connection

Base plate, ports 2 and 4 on side

- standard ISO 15407-1
- Frame size 26 mm
- type B
- Compressed air connection output G 1/4 1/4 - 18 NPTF
- Can be assembled into blocks
- Base plate principle, multiple
- Reversed pressure supply permissible
- With collective pilot air exhaust

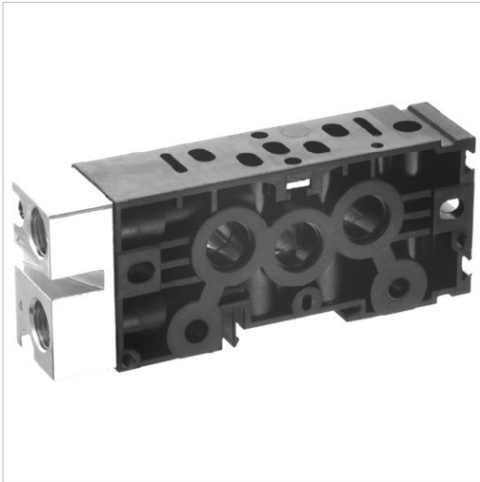

Standards	ISO 15407-1
Compressed air connection	according to ISO 15407-1
Working pressure min./max.	-0.95 ... 16 bar
Ambient temperature min./max.	-25 ... 70 °C
Medium temperature min./max.	-25 ... 70 °C
Medium	Compressed air
Number of valve positions max.	1
Grid dimension	27 mm
Direction of pneumatic port (2,4)	On the side
Exhaust (3,5)	With directional exhaust (3/5)
Exhaust type	Ports separated
Mounting screw	with hexagon socket
Tightening torque for mounting screws	4 Nm
Weight	0.165 kg

Technical data

Part No.	Compressed air connection Output [2 / 4]
R412004384	G 1/4
R412004386	1/4 - 18 NPTF

Scope of delivery incl. seal and mounting screws

Technical information

The min. control pressure must be adhered to, since otherwise faulty switching and valve failure may result!
 The pressure dew point must be at least 15 °C under ambient and medium temperature and may not exceed 3 °C .
 The oil content of compressed air must remain constant during the life cycle.
 Use only the approved oils from AVENTICS. Further information can be found in the "Technical information" document (available in the MediaCentre).

Technical information

Material	
Base plate	Aluminum Polyamide fiber-glass reinforced
Seal	Acrylonitrile butadiene rubber

Dimensions

Dimensions

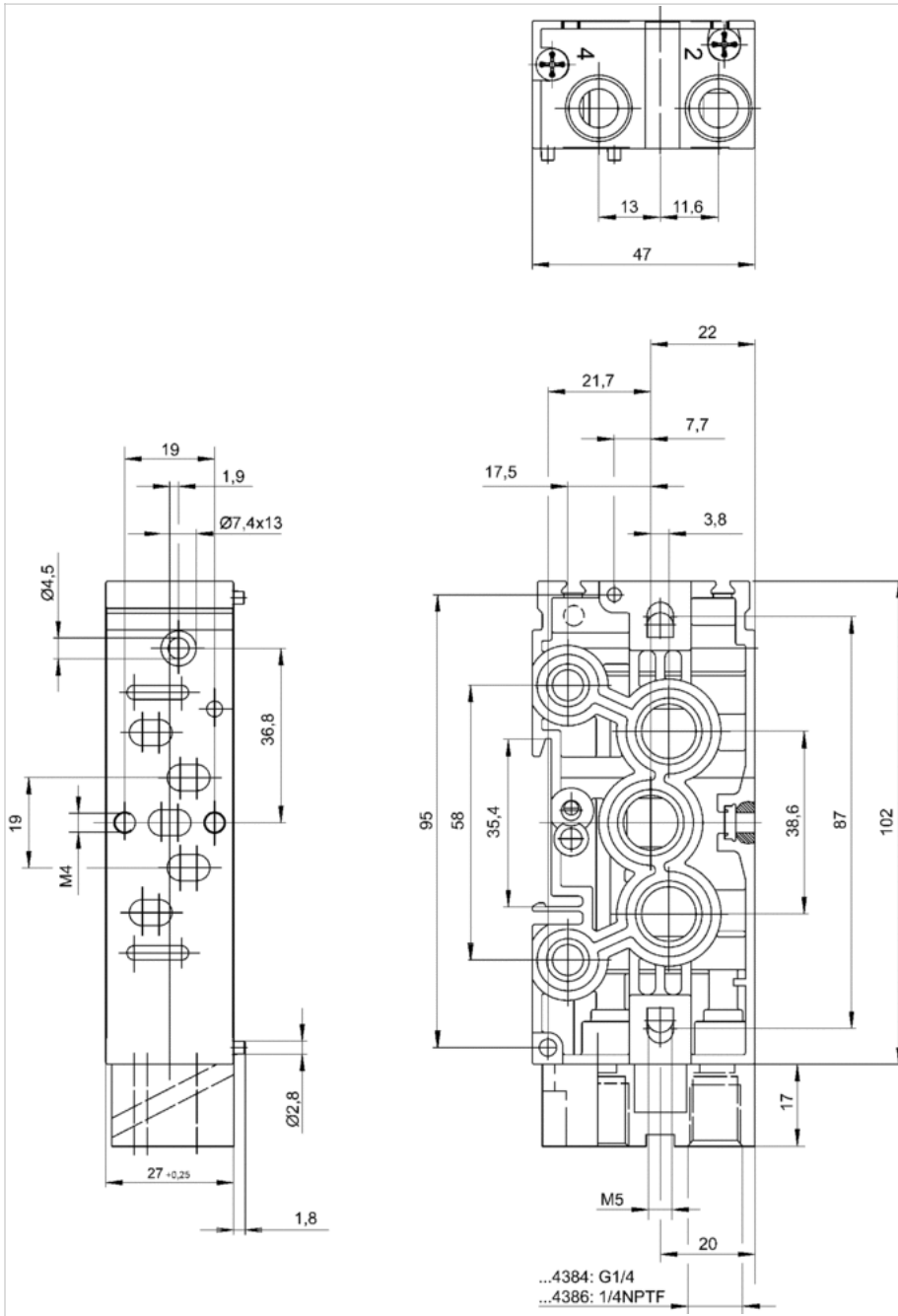

Mounting kit for DIN rails DIN

- standard 26 mm

- type A



Weight

0.014 kg

Technical data

Part No.	Type	Accessory type	Frame size	Delivery unit
1821398007	Mounting kit for DIN rails EN 60715, 35x15	type A	26 mm	1 piece

Dimensions

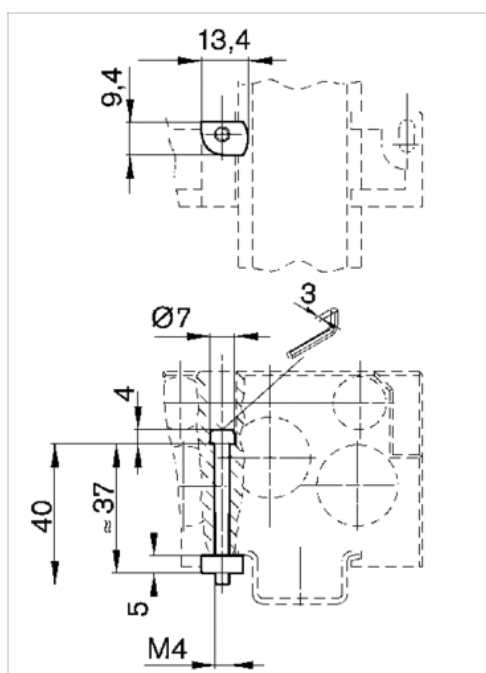

Separator

- for MS01-AL, CD01-PA
- standard ISO 15407-1, 26 mm
- type A



Standards	ISO 15407-1
Working pressure min./max.	-0.95 ... 16 bar
Ambient temperature min./max.	-15 ... 50 °C
Weight	See table below

Technical data

Part No.	Type	Accessory type	Frame size	Weight
1820220039	Separator for connections 1, 3, 5	type A	26 mm	0.004 kg
1820220040	For connections 12 and 14	type A	26 mm	0.002 kg

Technical information

Material	
Housing	Aluminum
Seal	Acrylonitrile butadiene rubber

Dimensions

Dimensions

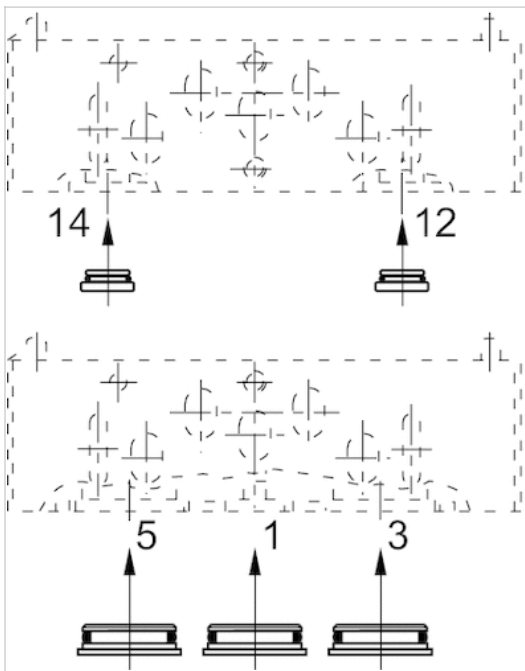

Supply plate, stacked longitudinally

- standard ISO 15407-1
- Frame size 26 mm
- type A
- Can be assembled into blocks
- Plate principle



Standards	ISO 15407-1
Working pressure min./max.	-0.95 ... 16 bar
Ambient temperature min./max.	-15 ... 70 °C
Medium temperature min./max.	-15 ... 70 °C
Medium	Compressed air
Grid dimension	28 mm
Direction of pneumatic port (1)	Up
Direction of pneumatic port (3,5)	Up
Mounting screw	with hexagon socket
Weight	0.268 kg

Technical data

Part No.	Compressed air connection	Compressed air connection
	Input	Exhaust
1825504034	[1] G 3/8	[3 / 5] G 3/8

Scope of delivery incl. seal and mounting screws

Technical information

The min. control pressure must be adhered to, since otherwise faulty switching and valve failure may result!
 The pressure dew point must be at least 15 °C under ambient and medium temperature and may not exceed 3 °C .
 The oil content of compressed air must remain constant during the life cycle.
 Use only the approved oils from AVENTICS. Further information can be found in the "Technical information" document (available in the MediaCentre).

Technical information

Material	
Base plate	Aluminum
Seal	Acrylonitrile butadiene rubber

Dimensions

Dimensions

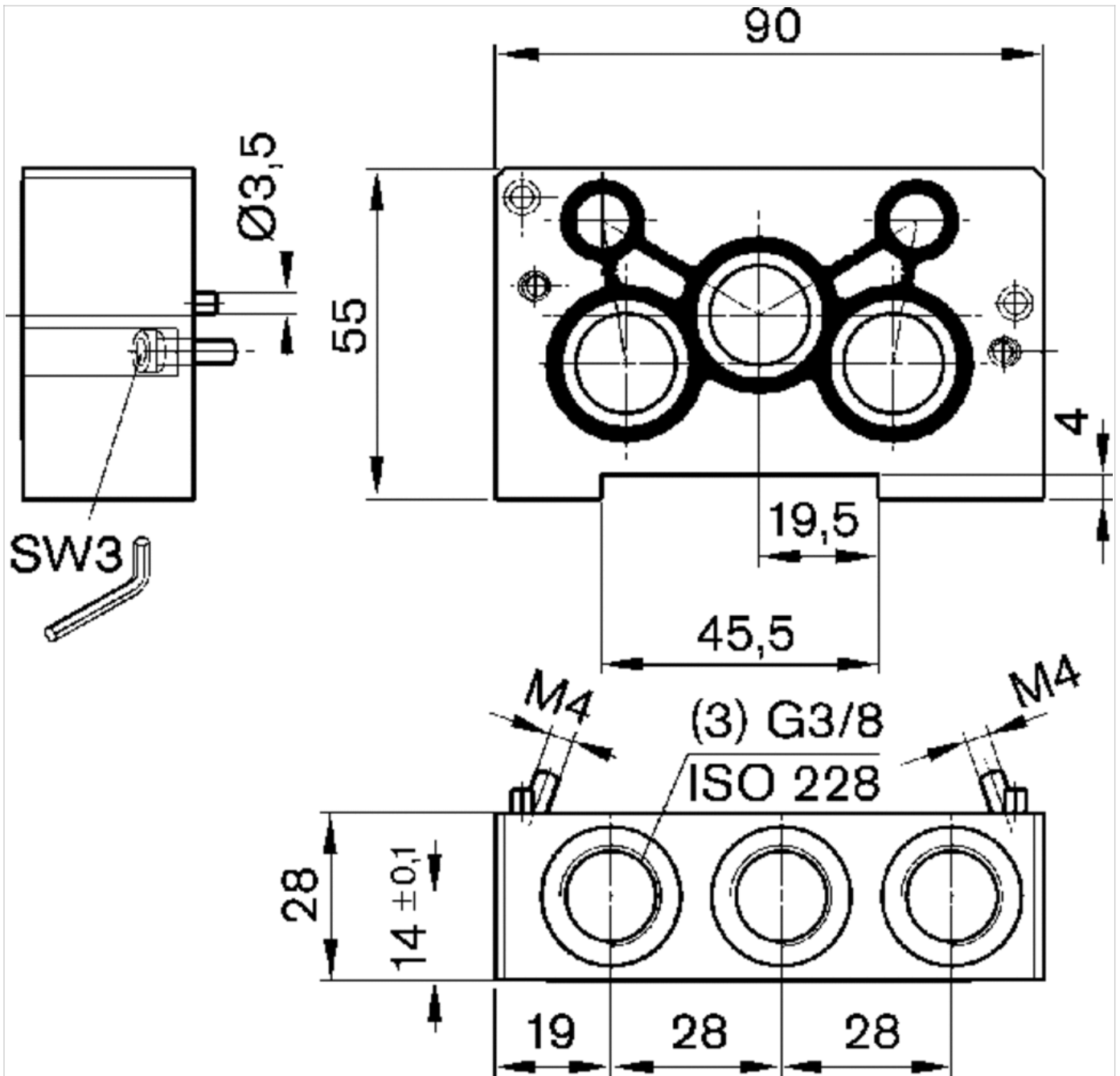

Check-choke valve

- Qn 1►2 = 810 l/min
- Qn 2►1 = 680 l/min
- direction of throttle 2 ► 1



Working pressure min./max.	0.5 ... 10 bar
Ambient temperature min./max.	0 ... 50 °C
Medium temperature min./max.	0 ... 50 °C
Medium	Compressed air
Weight	0.045 kg

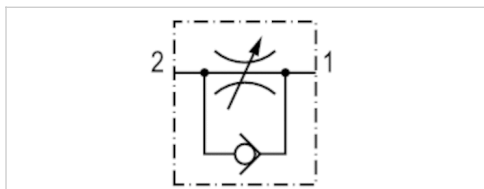

Technical data

Part No.	Port 1	Port 2	Flow	
			Qn 1►2	Qn 2►1
5341300000	Ø 8	Ø 8	810 l/min	680 l/min

Technical information

Material	
Housing	Polyamide
Seals	Acrylonitrile butadiene rubber

Dimensions

Dimensions

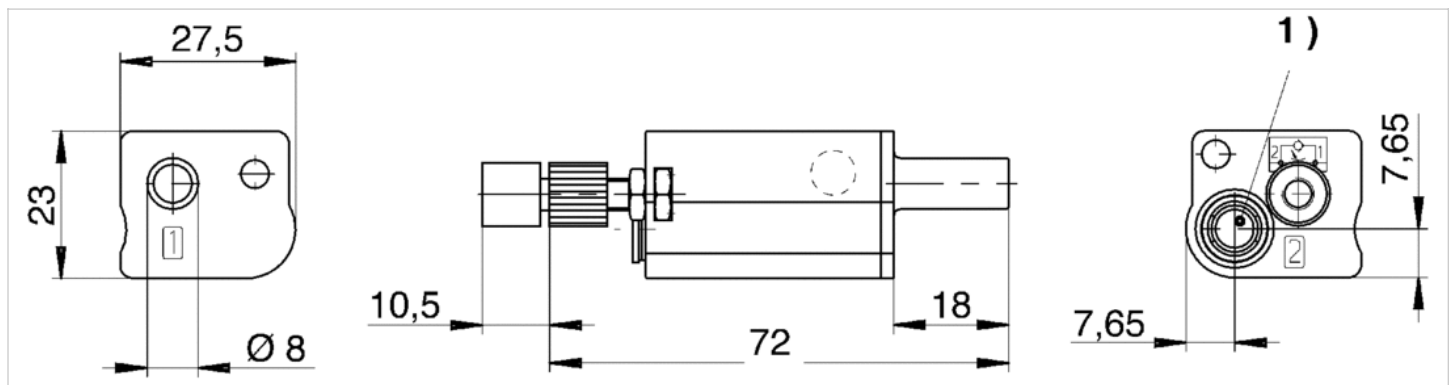

1) Push-in fitting diameter $\text{Ø} 8$

Separator

- for MS01-PA, CD01-PA
- standard ISO 15407-1, 26 mm
- type B



Standards
Weight

ISO 15407-1
0.003 kg

Technical data

R412015167	Separator for connections 1, 3, 5	type B	26 mm
------------	-----------------------------------	--------	-------

Technical information

Housing	Aluminum
---------	----------

Dimensions

Dimensions

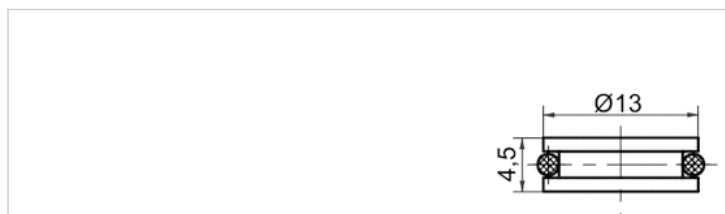

Pressure regulator for horizontal stacking

- type B
- $Q_n 1 \rightarrow 2 = 2100 \text{ l/min}$
- Actuating element Screw with wrench flats Slotted screw
- Base plate connection push-in fitting
- Poppet valve

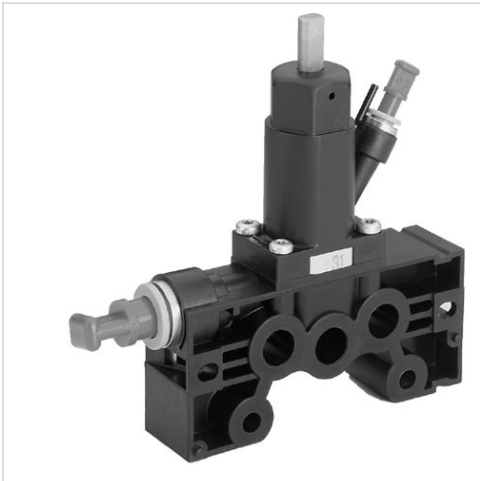

Version	Poppet valve
Certificates	Free of substances that impair surface wetting in the coating process
Working pressure min./max.	2 ... 10 bar
Adjustment range min./max.	0.8 ... 8 bar
Ambient temperature min./max.	-15 ... 50 °C
Medium temperature min./max.	-15 ... 50 °C
Medium	Compressed air
Max. particle size	50 µm
Oil content of compressed air	0 ... 1 mg/m ³
Weight	See table below

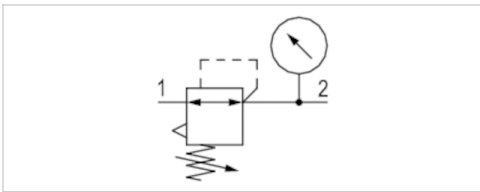

Technical data

Part No.	Compressed air connection Input	Compressed air connection type Input
5750020000	Special base plate Ø 12	Base plate connection push-in fitting
R412003769	Special base plate Ø 12	Base plate connection push-in fitting

Part No.	Compressed air connection Gauge port	Flow	Actuating element	Weight
		$Q_n 1 \rightarrow 2$		
5750020000	Ø 6x1	2100 l/min	Screw with wrench flats	0.23 kg
R412003769	Ø 6x1	2100 l/min	Slotted screw	0.2 kg

Nominal flow Q_n at 6 bar and $\Delta p = 2 \text{ bar}$, Scope of delivery incl. seal and mounting screws, Order pressure gauge separately

Technical information

Material	
Housing	Polyamide fiber-glass reinforced Polyoxymethylene
Seals	Acrylonitrile butadiene rubber

Dimensions

Dimensions

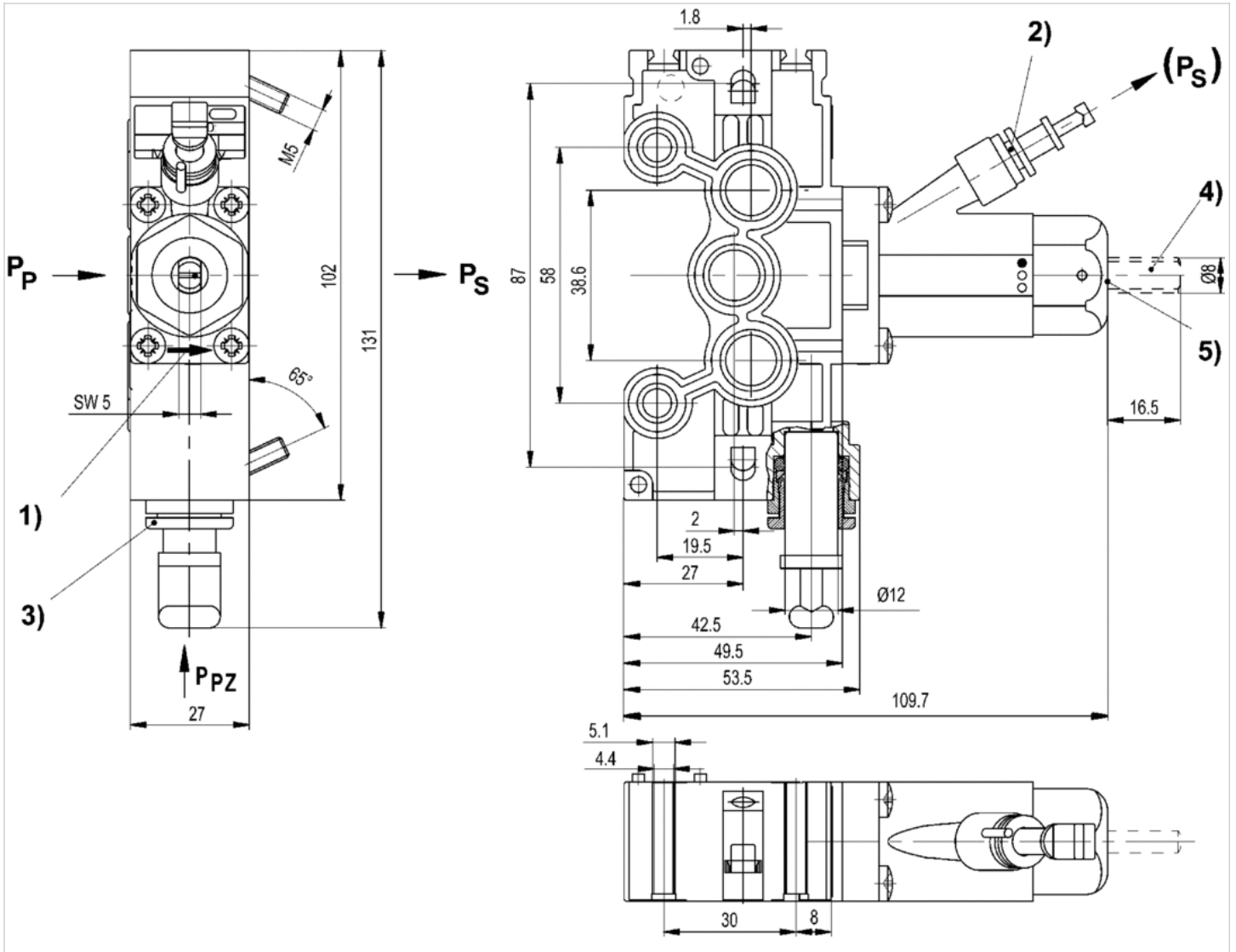

- 1) Flow direction
- 2) Push-in fitting $\varnothing 6 \times 1$ (for gauge)
- 3) Additional pressure feed possible (push-in fitting $\varnothing 12$)
- PP primary pressure PS secondary pressure PPZ additional primary pressure supply
- 4) activation with key SW 5
- 5) activation with screwdriver

Subbase

- standard ISO 15407-1
- Frame size 26 mm
- type B
- Can be assembled into blocks
- Base plate principle, multiple
- Reversed pressure supply permissible



Standards	ISO 15407-1
Working pressure min./max.	-0.95 ... 16 bar
Ambient temperature min./max.	-25 ... 70 °C
Medium temperature min./max.	-25 ... 70 °C
Medium	Compressed air
Grid dimension	22 mm
Direction of pneumatic port (1)	On the side
Direction of pneumatic port (3,5)	Up
Exhaust (3,5)	With directional exhaust (3/5)
Exhaust type	Ports separated
Mounting screw	with hexagon socket
Tightening torque for mounting screws	4 Nm

Technical data

Part No.	Compressed air connection Input [1]	Compressed air connection Exhaust [3 / 5]	Pilot	
R412000630	G 3/8	G 1/4	Internal	1)
R412000631	G 3/8	G 1/4	External	2)

- 1) for internally piloted valves, pilot air is diverted from connection 1 working pressure 2 bar , 3 bar ... 10 bar , 16 bar , depending on valve type
- 2) For externally piloted valves, external pilot air is fed in via the right supply plate, working pressure -0.95 to 10 (16) bar, depending on valve type

Technical information

The min. control pressure must be adhered to, since otherwise faulty switching and valve failure may result!
 The pressure dew point must be at least 15 °C under ambient and medium temperature and may not exceed 3 °C .
 The oil content of compressed air must remain constant during the life cycle.
 Use only the approved oils from AVENTICS. Further information can be found in the "Technical information" document (available in the MediaCentre).

Technical information

Material	
Base plate	Aluminum

Dimensions

Dimensions

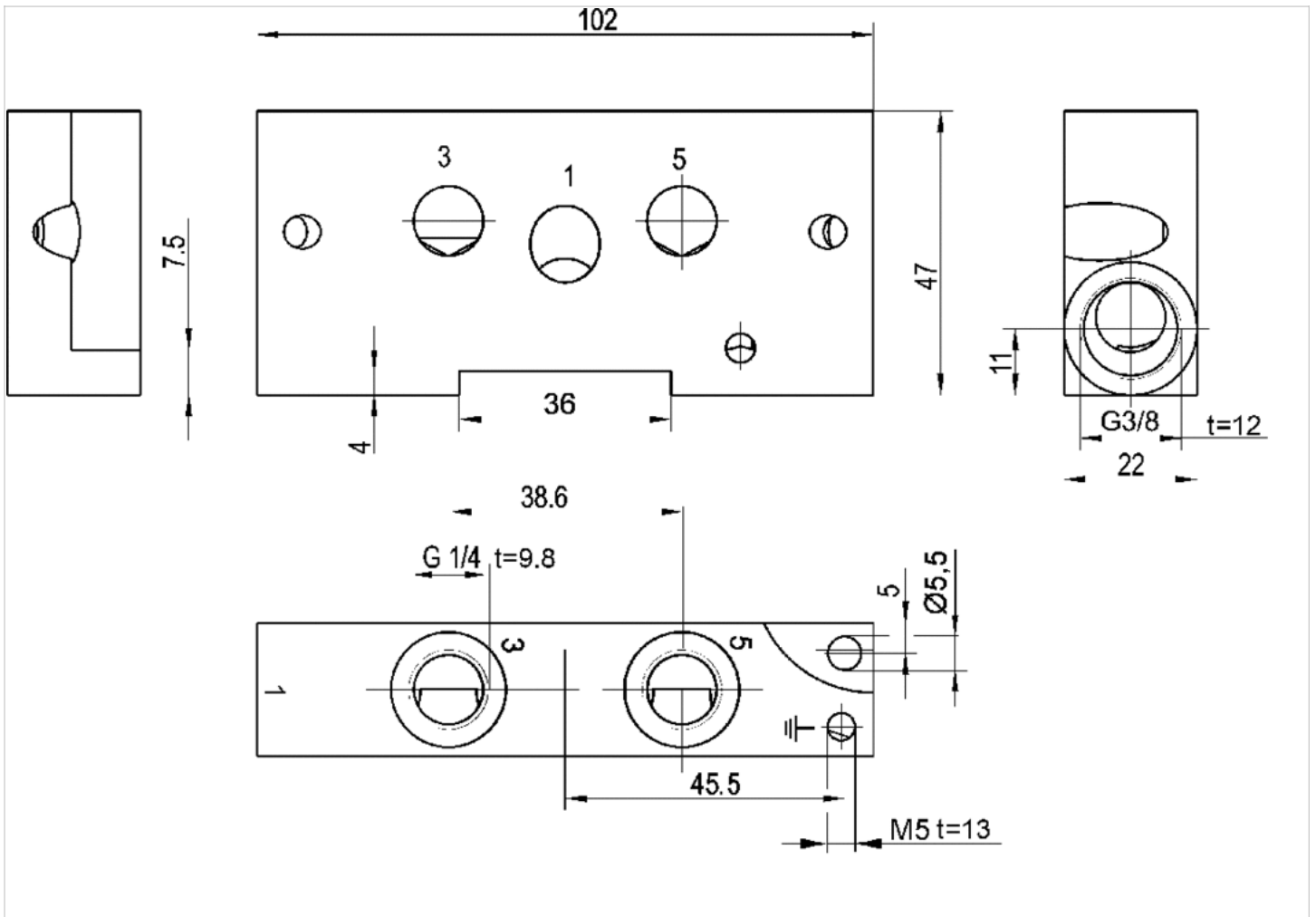

Pressure gauge

- Back port
- Background color White
- Scale color Black, Red
- Units bar
- Units psi



Ambient temperature min./max.	-15 ... 80 °C
Medium	Compressed air
Max. particle size	50 µm
Main scale unit (outside)	bar
Main scale color (outside)	Black
Secondary scale unit (inside)	psi
Secondary scale color (inside)	Red
Background color	White
Pointer color	Black
Weight	See table below

The delivered product may vary from that in the illustration.

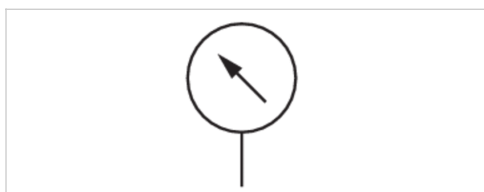

Technical data

Part No.	Compressed air connection	Nominal diameter	Range of application	Display range	Operating pressure	Scale value
R412003960	Ø 6	28 mm	0 ... 4	0 bar ... 4	0 ... 4 bar	-
3530200300	Ø 6	28 mm	0 ... 10	0 bar ... 10 bar	0 ... 10 bar	-
R412004883	Ø 6	28 mm	0 ... 10	0 bar ... 10 bar	0 ... 10 bar	1

Part No.	Weight
R412003960	0.016 kg
3530200300	0.016 kg
R412004883	0.02 kg

Included in the delivery contents: Straight push-in fitting, increasing (1823391628)

Technical information

Material	
Housing	Polyamide

Dimensions

Dimensions in mm

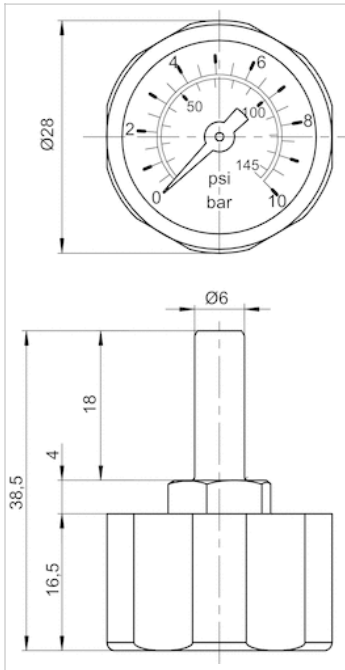

Pressure regulator for vertical stacking

- Qn 1►2 = 750 l/min
- standard ISO 15407-1
- Actuating element Screw with wrench flats
- Controlled port 3
- Poppet valve



Version	Poppet valve
Certificates	Free of substances that impair surface wetting in the coating process
Working pressure min./max.	2 ... 10 bar
Adjustment range min./max.	See table below
Ambient temperature min./max.	-15 ... 50 °C
Medium temperature min./max.	-15 ... 50 °C
Medium	Compressed air
Max. particle size	50 µm
Oil content of compressed air	0 ... 1 mg/m ³
Weight	0.2 kg

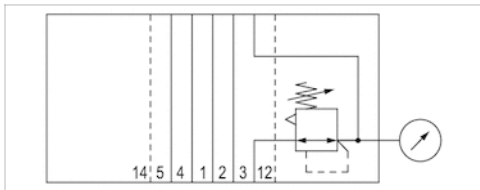

Technical data

Part No.	Compressed air connection Exhaust	Compressed air connection Gauge port	Adjustment range min./max.
5750020510	base plate DIN ISO 15407-1	Ø 6x1	0.8 ... 8 bar
5750020520	base plate DIN ISO 15407-1	Ø 6x1	3 ... 3 bar

Part No.	Flow	Actuating element	Controlled port	Fig.
	Qn 1►2			
5750020510	750 l/min	Screw with wrench flats	3	Fig. 1
5750020520	750 l/min	-	3	Fig. 2

Nominal flow with secondary pressure 6.3 bar at $\Delta p = 1$ bar, Scope of delivery incl. seal and mounting screws, Order pressure gauge separately

Technical information

Material	
Housing	Polyamide fiber-glass reinforced Polyoxymethylene
Seals	Acrylonitrile butadiene rubber

Dimensions

Fig. 1

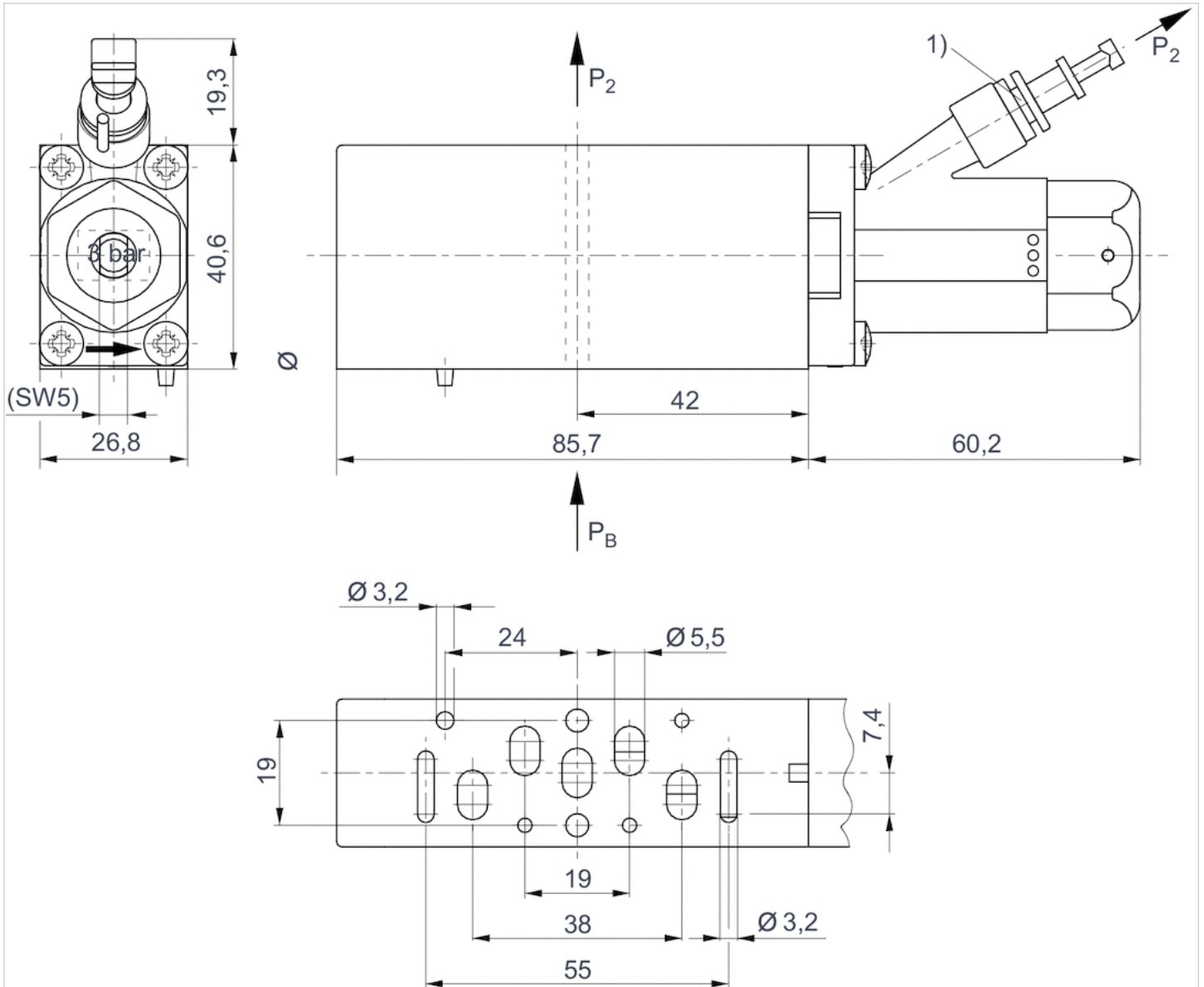

1) push-in fitting $\varnothing 6 \times 1$ (for pressure gauge) 2) preset at 3 bar
 p2 = secondary pressure
 PB= Working pressure

Fig. 2

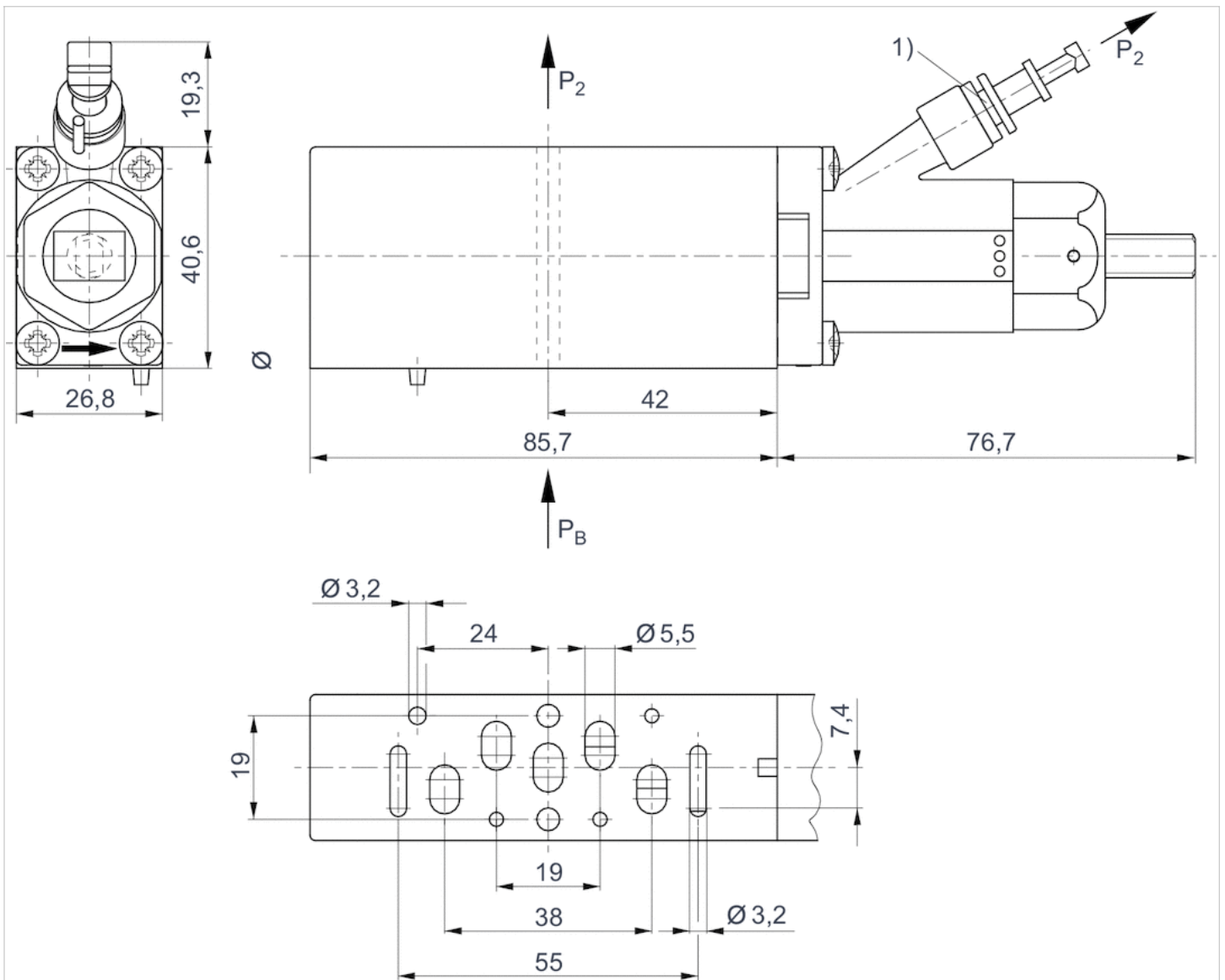

1) Push-in fitting Ø 6 x 1 (for gauge)
 p₂ = secondary pressure
 P_B = Working pressure

Throttle plate

- standard ISO 15407-1
- Frame size 26 mm



Standards	ISO 15407-1
Working pressure min./max.	0 ... 16 bar
Ambient temperature min./max.	-15 ... 70 °C
Medium temperature min./max.	-15 ... 70 °C
Medium	Compressed air
Weight	0.17 kg

Technical data

Part No.
0821201022

Scope of delivery incl. seal and mounting screws

Technical information

The min. control pressure must be adhered to, since otherwise faulty switching and valve failure may result!
 The pressure dew point must be at least 15 °C under ambient and medium temperature and may not exceed 3 °C .
 The oil content of compressed air must remain constant during the life cycle.
 Use only the approved oils from AVENTICS. Further information can be found in the "Technical information" document (available in the MediaCentre).

Technical information

Material	
Base plate	Aluminum
Seal	Acrylonitrile butadiene rubber

Dimensions

Dimensions

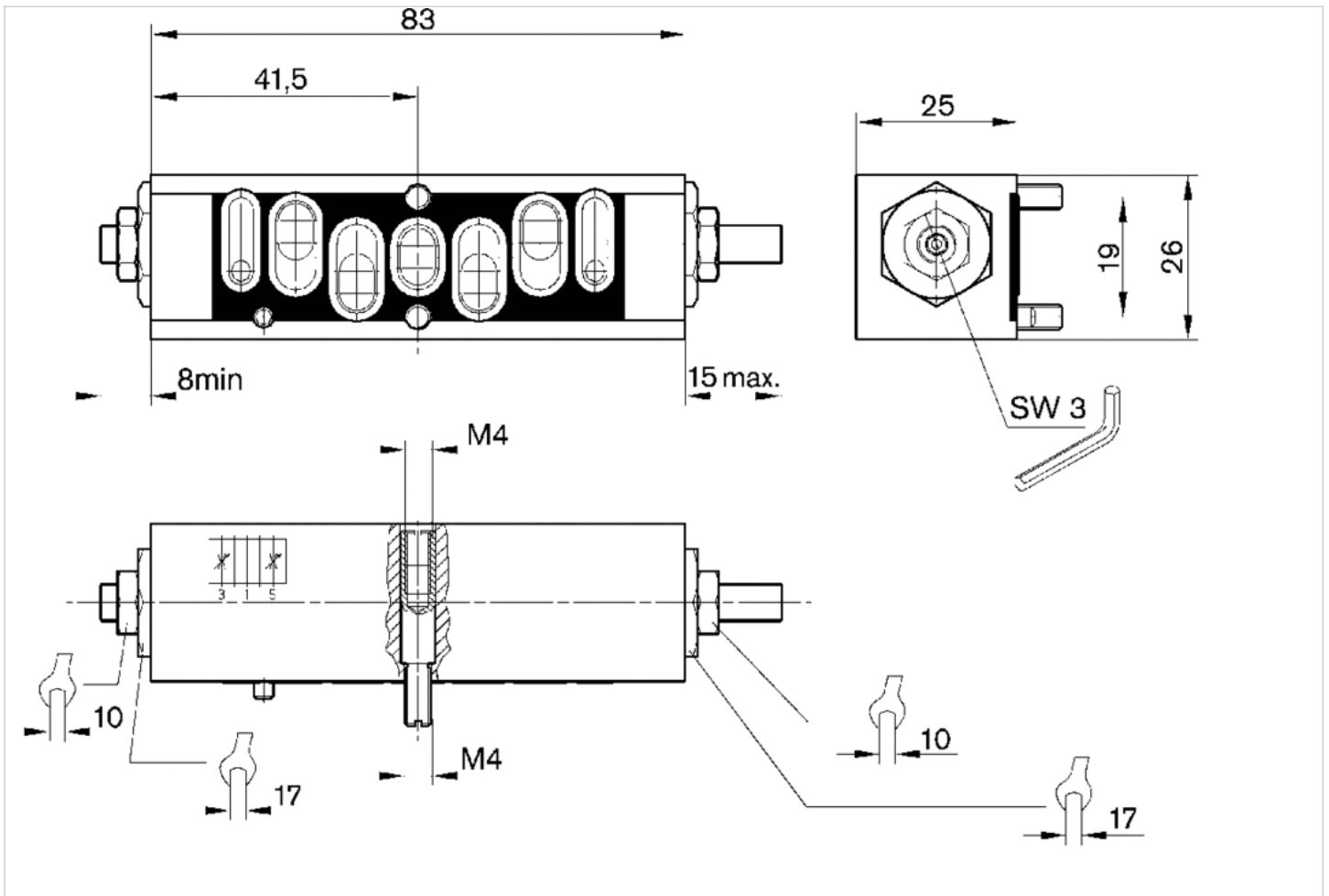

Supply plate, stacked vertically

- standard ISO 15407-1
- Frame size 26 mm
- Single base plate principle
- Reversed pressure supply permissible



Standards	ISO 15407-1
Compressed air connection	according to ISO 15407-1
Working pressure min./max.	-0.95 ... 16 bar
Ambient temperature min./max.	-15 ... 70 °C
Medium temperature min./max.	-15 ... 70 °C
Medium	Compressed air
Number of valve positions max.	1
Direction of pneumatic port (1)	On the side
Exhaust (3,5)	With directional exhaust (3/5)
Exhaust type	Ports separated
Mounting screw	with hexagon socket
Tightening torque for mounting screws	2.5 Nm
Weight	0.112 kg

Technical data

Part No.	Compressed air connection
1825504035	Input [1] G 1/4

Scope of delivery incl. seal and mounting screws

Technical information

The min. control pressure must be adhered to, since otherwise faulty switching and valve failure may result!
 The pressure dew point must be at least 15 °C under ambient and medium temperature and may not exceed 3 °C .
 The oil content of compressed air must remain constant during the life cycle.
 Use only the approved oils from AVENTICS. Further information can be found in the "Technical information" document (available in the MediaCentre).

Technical information

Material	
Base plate	Aluminum
Seal	Acrylonitrile butadiene rubber

Dimensions

Dimensions

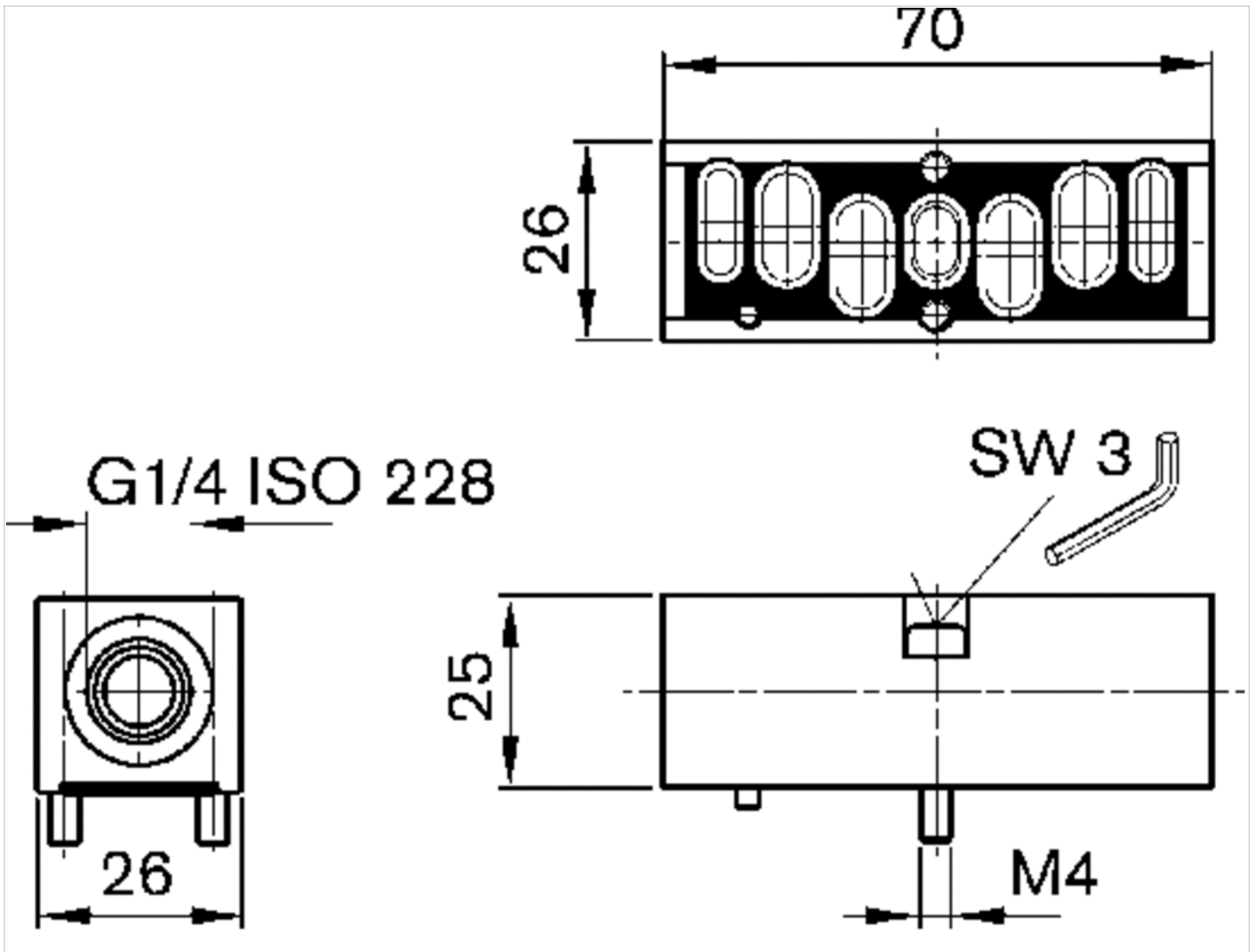

Supply module

- standard ISO 15407-1
- Frame size 26 mm
- Can be assembled into blocks
- Single base plate principle
- Reversed pressure supply permissible



Standards	ISO 15407-1
Compressed air connection	according to ISO 15407-1
Working pressure min./max.	-0.95 ... 16 bar
Ambient temperature min./max.	-15 ... 50 °C
Medium temperature min./max.	-15 ... 50 °C
Medium	Compressed air
Number of valve positions max.	1
Grid dimension	27 mm
Direction of pneumatic port (1)	On the side
Direction of pneumatic port (3,5)	Up
Exhaust (3,5)	With directional exhaust (3/5)
Exhaust type	Ports separated
Mounting screw	with hexagon socket
Tightening torque for mounting screws	2.5 Nm

Technical data

Part No.	Compressed air connection Input [1]	Compressed air connection Exhaust [3 / 5]
8985121472	Ø 8x1	Ø 8x1

Blanking plug included in scope of delivery. For applications with base plates in accordance with ISO 15407-2, protective cap R412005856 must be ordered separately.

Technical information

The min. control pressure must be adhered to, since otherwise faulty switching and valve failure may result!
 The pressure dew point must be at least 15 °C under ambient and medium temperature and may not exceed 3 °C .
 The oil content of compressed air must remain constant during the life cycle.
 Use only the approved oils from AVENTICS. Further information can be found in the "Technical information" document (available in the MediaCentre).

Technical information

Material	
Base plate	Polyamide fiber-glass reinforced
Seal	Acrylonitrile butadiene rubber

Dimensions

Dimensions

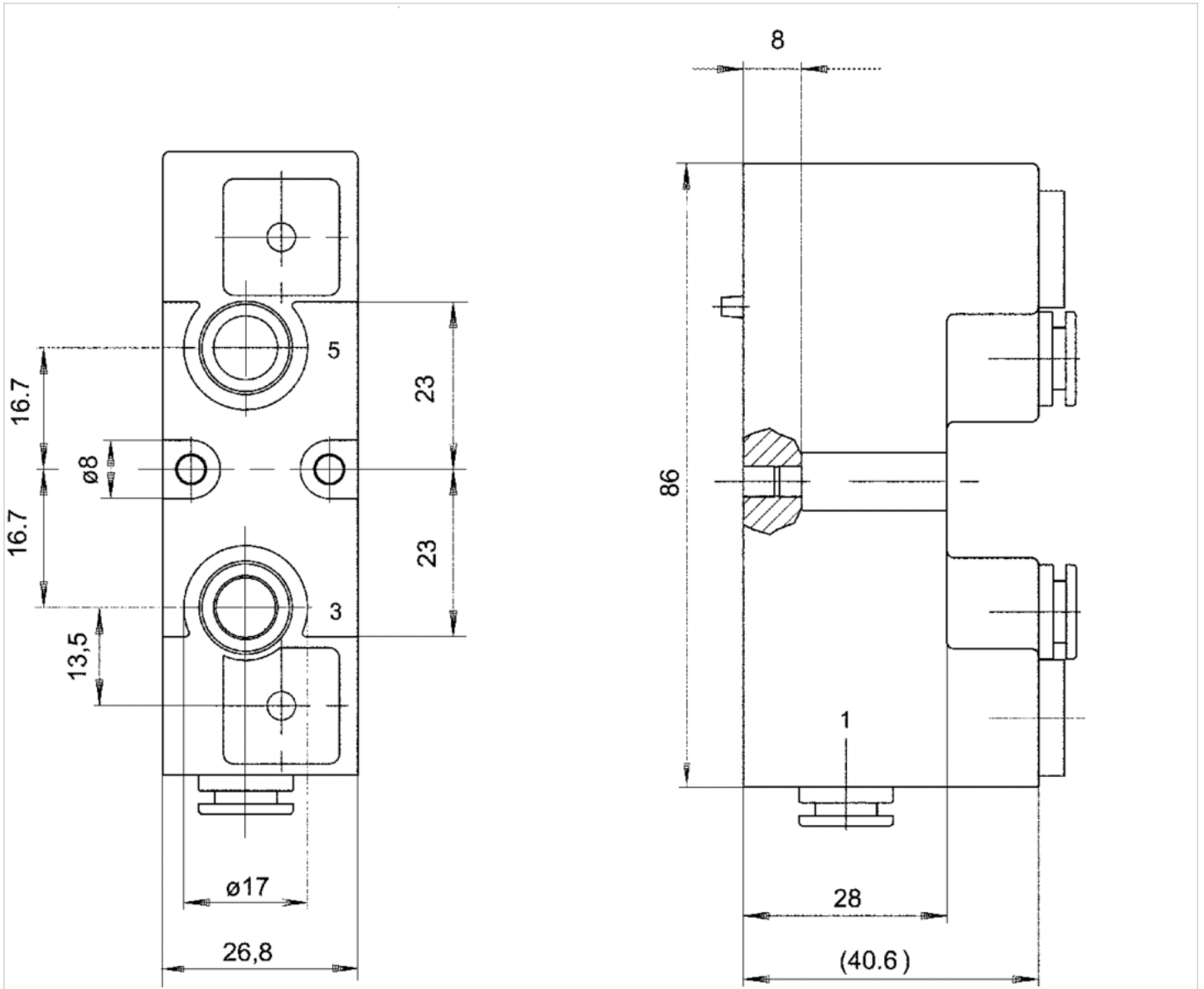

Pressure regulator for vertical stacking

- Qn 1►2 = 750 l/min
- Actuating element Screw with wrench flats
- Base plate connection
- Controlled port 1
- Poppet valve



Version	Poppet valve
Certificates	Free of substances that impair surface wetting in the coating process
Working pressure min./max.	2 ... 10 bar
Adjustment range min./max.	See table below
Ambient temperature min./max.	-15 ... 50 °C
Medium temperature min./max.	-15 ... 50 °C
Medium	Compressed air
Max. particle size	50 µm
Oil content of compressed air	0 ... 1 mg/m ³
Weight	0.21 kg

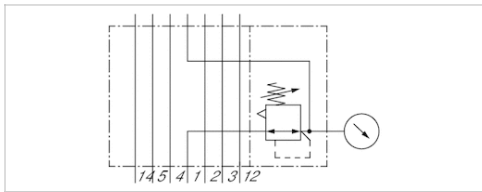

Technical data

Part No.	Compressed air connection Input	Compressed air connection type Input
5750020500	base plate DIN ISO 15407-1	Base plate connection
R412003719	base plate DIN ISO 15407-1	Base plate connection
5750020530	base plate DIN ISO 15407-1	Base plate connection

Part No.	Compressed air connection Gauge port	Adjustment range min./max.	Flow
			Qn 1►2
5750020500	Ø 6x1	0.8 ... 8 bar	750 l/min
R412003719	Ø 6x1	0.5 ... 4 bar	750 l/min
5750020530	Ø 6x1	3 ... 3 bar	750 l/min

Part No.	Actuating element	Controlled port	Fig.
5750020500	Screw with wrench flats	1	Fig. 2
R412003719	Screw with wrench flats	1	Fig. 2
5750020530	-	1	Fig. 1

Nominal flow with secondary pressure 6.3 bar at $\Delta p = 1$ bar, Scope of delivery incl. seal and mounting screws, Order pressure gauge separately

Technical information

Housing	Polyamide fiber-glass reinforced Polyoxymethylene
---------	---

Dimensions

Fig. 1

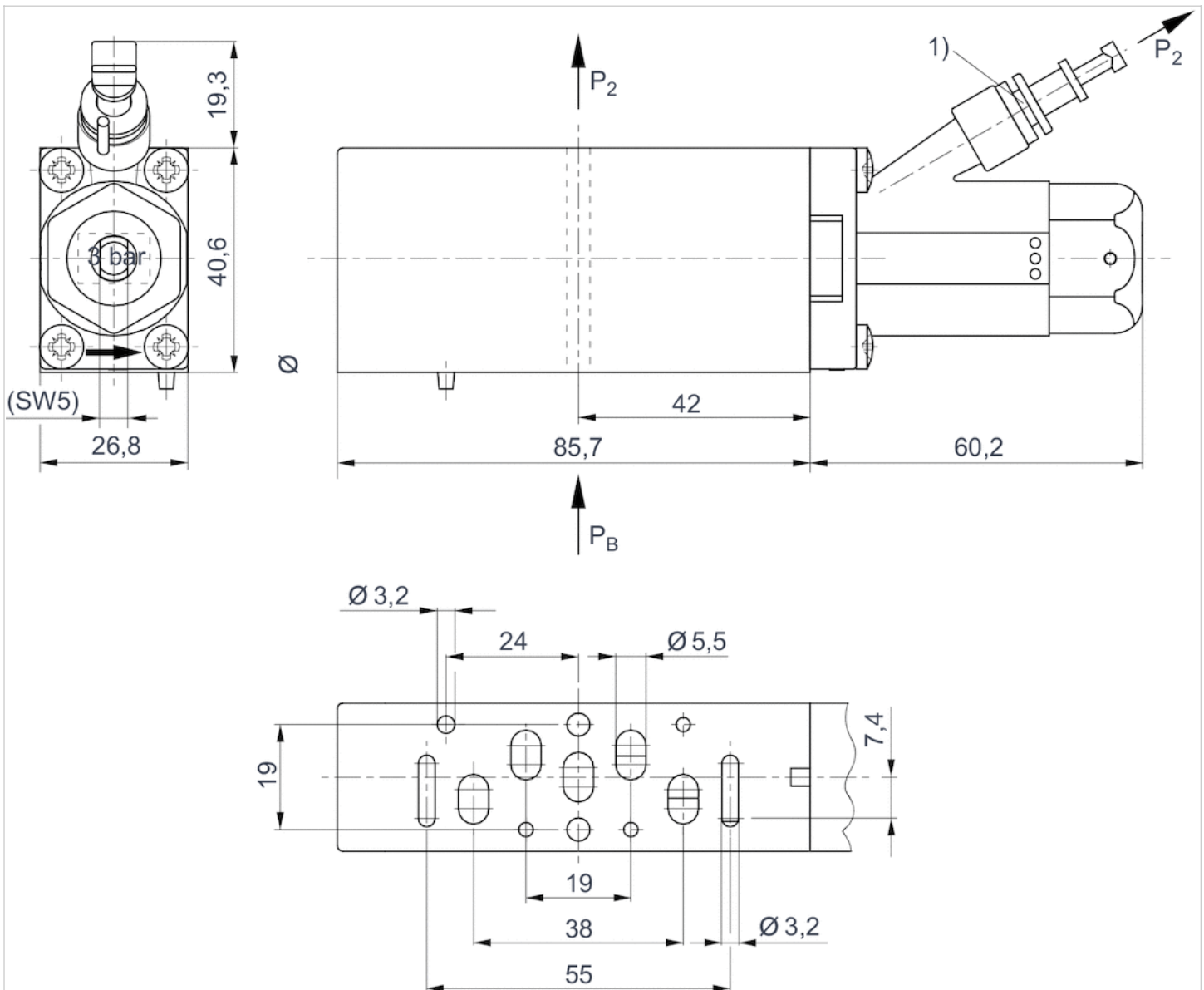

1) push-in fitting $\varnothing 6 \times 1$ (for pressure gauge) 2) preset at 3 bar
 p_2 = secondary pressure
 P_B = Working pressure

Fig. 2

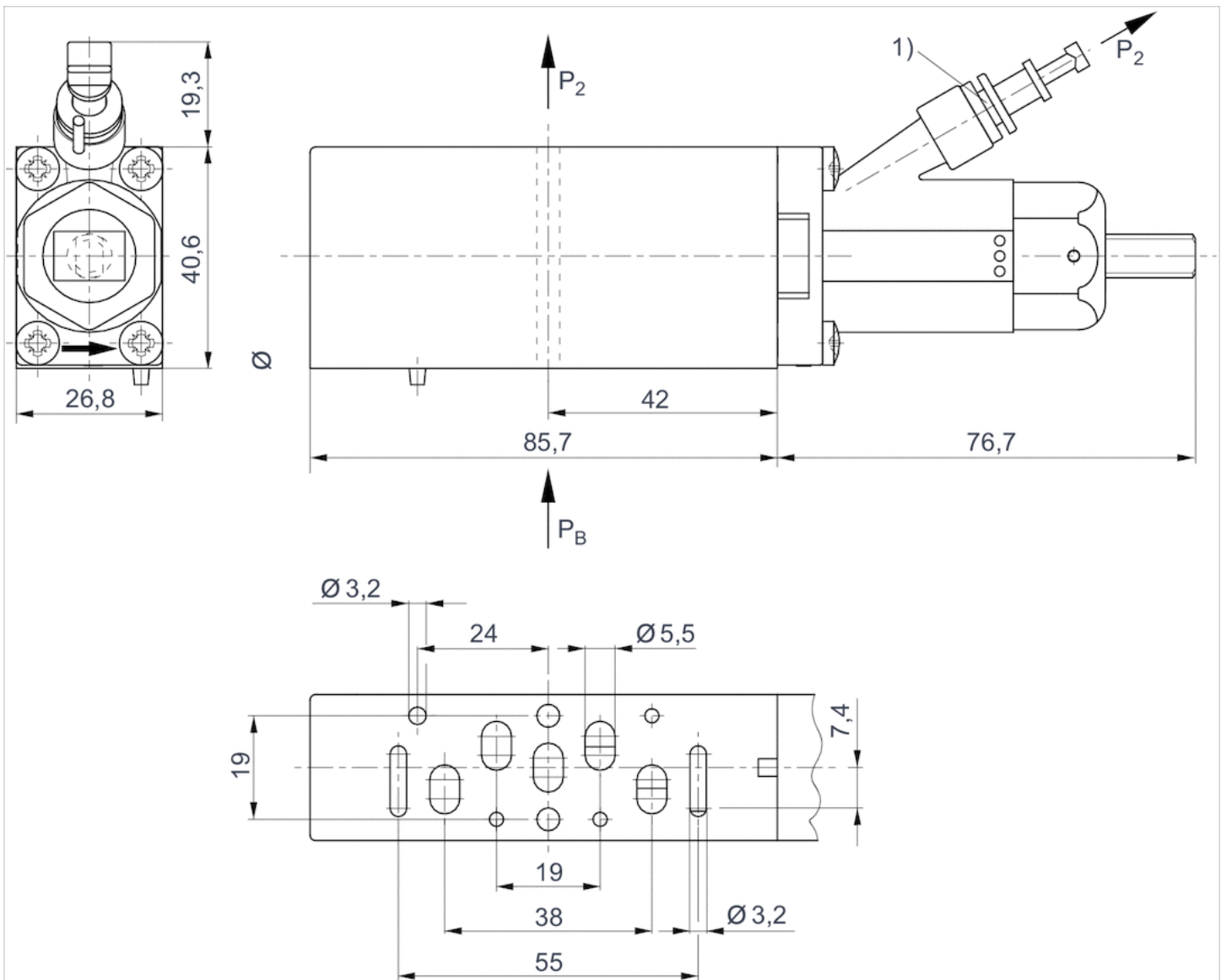

1) Push-in fitting $\varnothing 6 \times 1$ (for gauge)
 p_2 = secondary pressure
 P_B = Working pressure

Blanking plate

- standard ISO 15407-1
- Frame size 26 mm
- Can be assembled into blocks
- Single base plate principle
- Reversed pressure supply permissible



Standards	ISO 15407-1
Compressed air connection	according to ISO 15407-1
Working pressure min./max.	-0.95 ... 16 bar
Ambient temperature min./max.	-15 ... 50 °C
Medium temperature min./max.	-15 ... 50 °C
Medium	Compressed air
Number of valve positions max.	1
Grid dimension	27 mm
Mounting screw	with hexagon socket
Tightening torque for mounting screws	2.5 Nm
Weight	0.088 kg

An example configuration is illustrated.
The delivered product may thus deviate from the illustration.

Technical data

Part No.

8985121492

For applications with base plates in accordance with ISO 15407-2, protective cap R412005856 must be ordered separately.

Technical information

The min. control pressure must be adhered to, since otherwise faulty switching and valve failure may result!

The pressure dew point must be at least 15 °C under ambient and medium temperature and may not exceed 3 °C .

The oil content of compressed air must remain constant during the life cycle.

Use only the approved oils from AVENTICS. Further information can be found in the "Technical information" document (available in the MediaCentre).

I/O functionality by combining with contact bridge kit for additional inputs/outputs

Technical information

Material

Base plate

Polyamide fiber-glass reinforced

Seal

Acrylonitrile butadiene rubber

Dimensions

Dimensions

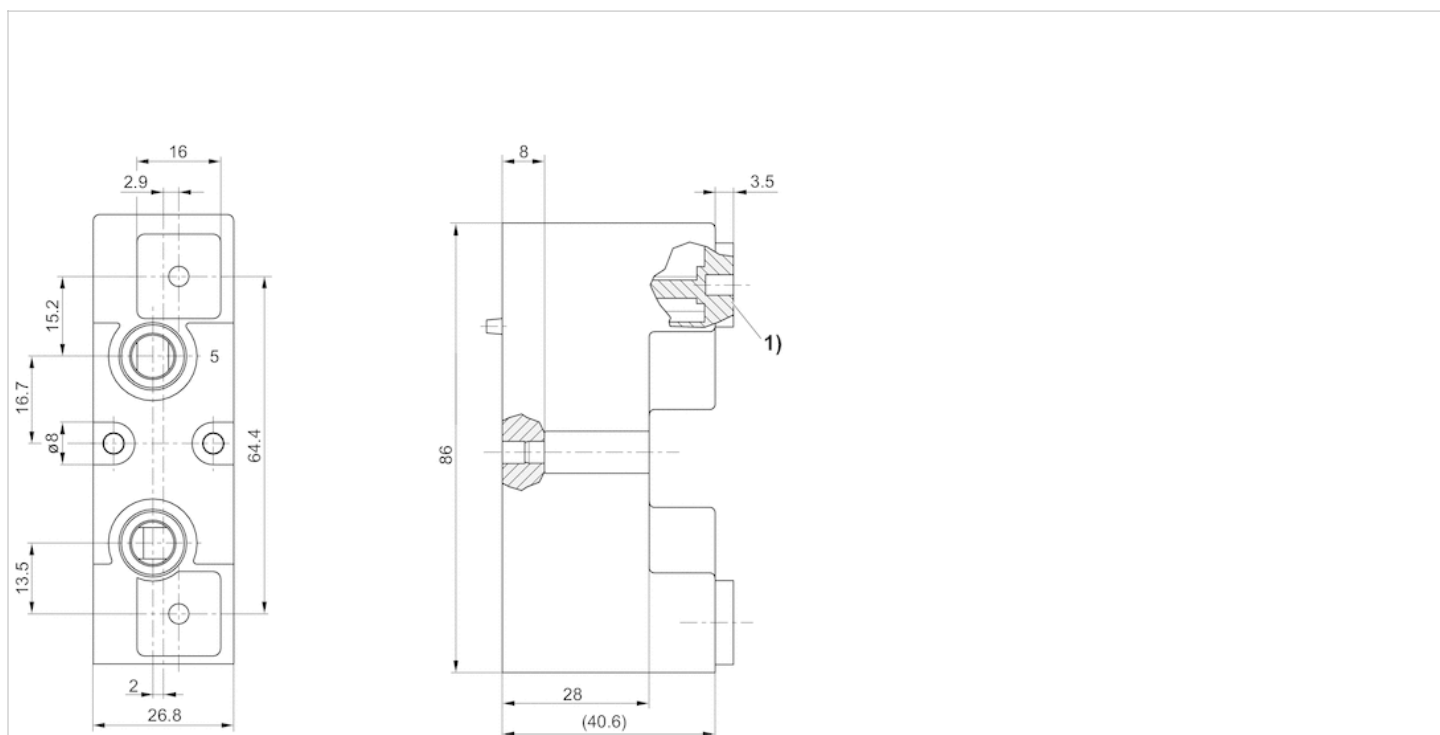

1) Mounting hole for M2.5 thread insert

Contact bridges, series CON-CB

- Plug, 4-pin, straight, 180°
- Socket, form C, 2-pin, straight
- Number of solenoid coils 1



Ambient temperature min./max.	-15 ... 50 °C
Protection class	IP65
Operational voltage	24 V AC/DC
Voltage tolerance AC 50 Hz	-10% / +10%
Voltage tolerance AC 60 Hz	-10% / +10%
Valve LED status display	Yellow
Mounting screw	M2.5 with slot
Tightening torque for mounting screws [+0,05]	0.25 Nm
Weight	0.016 kg

Technical data

Part No.
5763573113

Technical information

Material	
Housing	Polyester amide
Seals	Fluorocaoutchouc

Dimensions

Dimensions

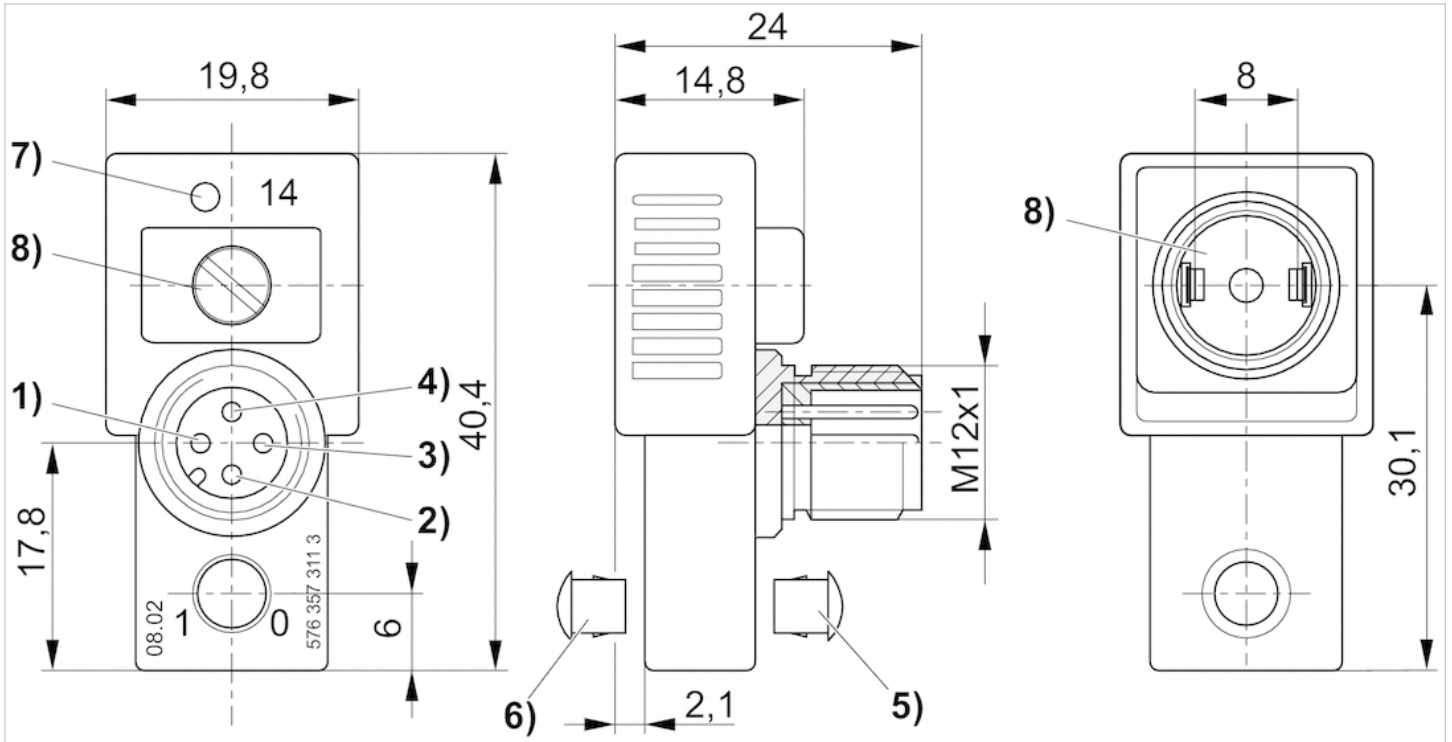

- 1) not assigned
- 2) not assigned
- 3) 0 V
- 4) magnet 14
- 5) Sealing cap for manual override not removable
- 6) Removable
- 7) LED valve
- 8) captive seal and screw

Valve plug connector, series CON-VP

- Socket, form C, 2+E, angled, 90°
- ISO 15217
- unshielded
- with LED Green



Connection type	Screws
Ambient temperature min./max.	-40 ... 90 °C
Operational voltage	See table below
Protection class	IP65
Mounting screw tightening torque	0.4 Nm
Weight	See table below

Technical data

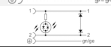
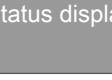
Part No.		Operational voltage	Max. current	Protective circuit	Contact assignment
1834484187		250 / 300 V AC/DC	6 A	-	2+E
8941012202		250 / 300 V AC/DC	6 A	-	2+E
4402050330		24 V AC/DC	-	Z-diode	2+E

Part No.	LED status display	suitable cable-Ø min./max	Seal	Weight
1834484187	-	4 / 8 mm	caoutchouc/butadiene caoutchouc	0.012 kg
8941012202	-	4 / 8 mm	-	0.012 kg
4402050330	Green	-	-	0.014 kg

Part No.	Fig.	
1834484187	Fig. 1	-
8941012202	Fig. 2	-
4402050330	Fig. 3	1)

1)

Technical information

The specified protection class is only valid in assembled and tested state.

Technical information

Material

Seals

caoutchouc/butadiene caoutchouc

Dimensions

Fig. 1

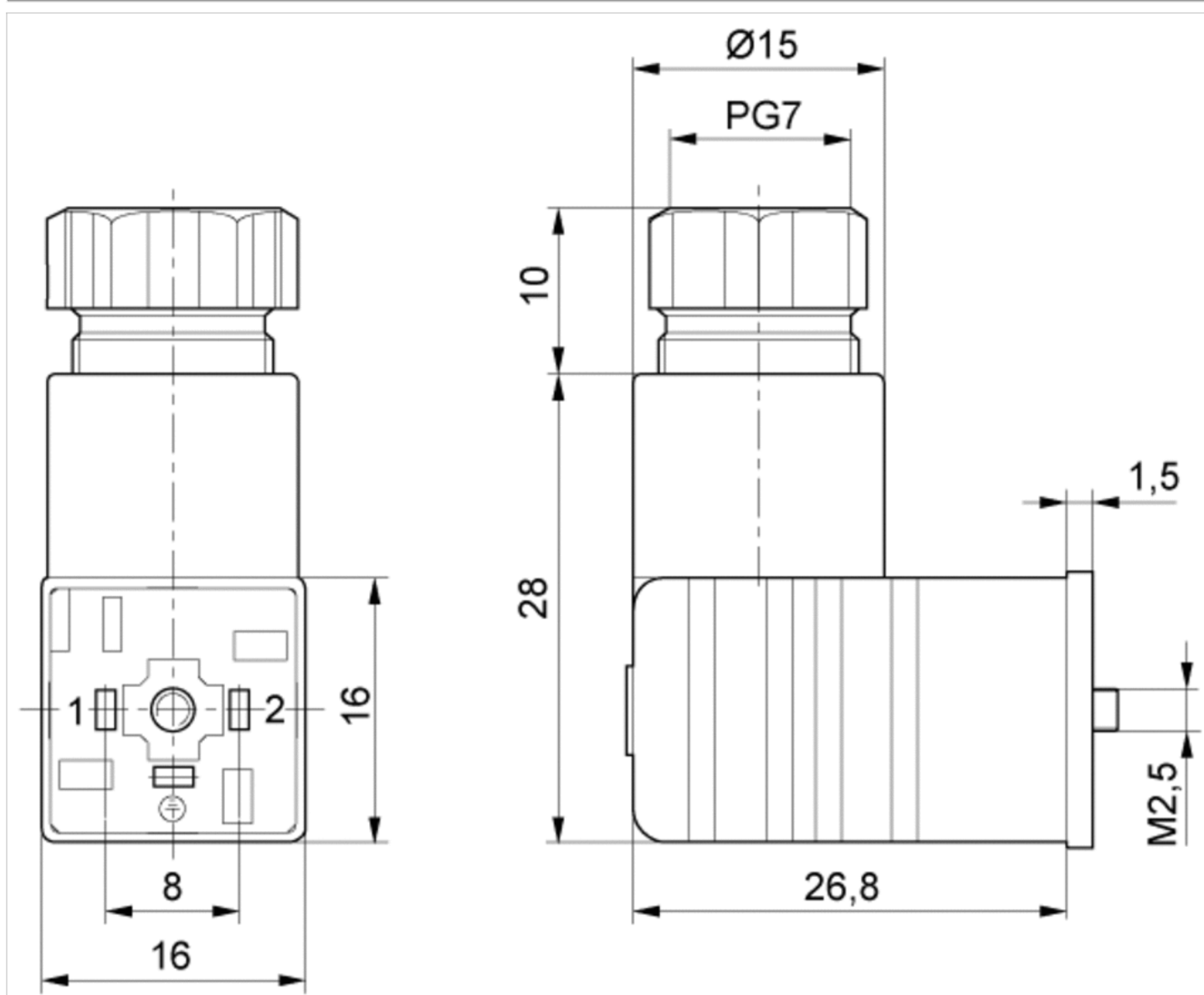

Fig. 2

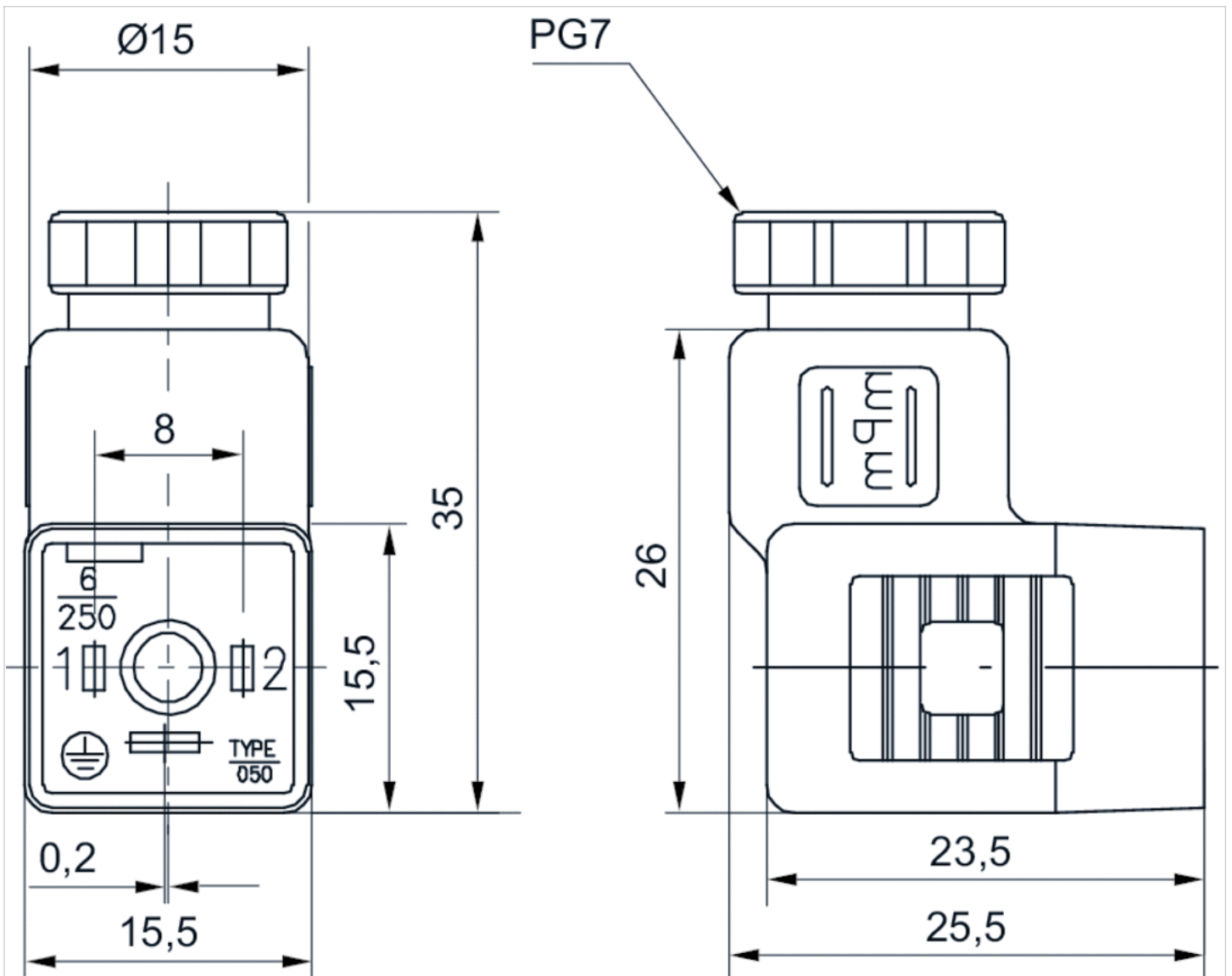
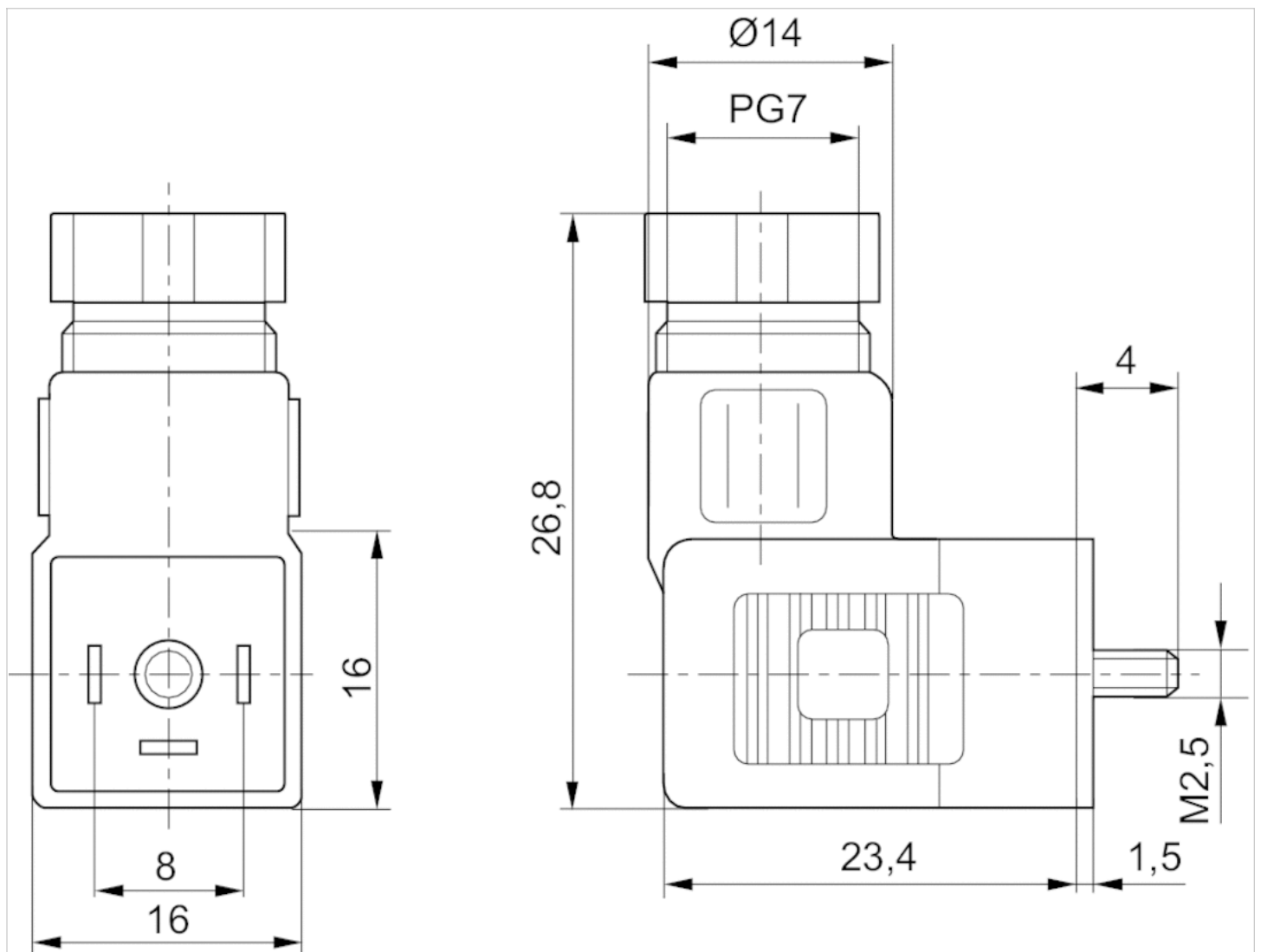

Fig. 3



Contact bridges, series CON-CB

- Plug, 4-pin, straight, 180°
- Socket, form C, 2-pin, straight
- Socket, form C, 2-pin, straight
- Number of solenoid coils 2



Ambient temperature min./max.	-15 ... 50 °C
Protection class	IP65
Operational voltage	24 V AC/DC
Voltage tolerance AC 50 Hz	-10% / +10%
Voltage tolerance AC 60 Hz	-10% / +10%
Valve LED status display	Yellow
Mounting screw	M2.5 with slot
Tightening torque for mounting screws [+0,05]	0.25 Nm
Weight	0.026 kg

Technical data

Part No.

5763573103

Technical information

Material

Housing	Polyester amide
Seals	Fluorocaoutchouc

Dimensions

Dimensions

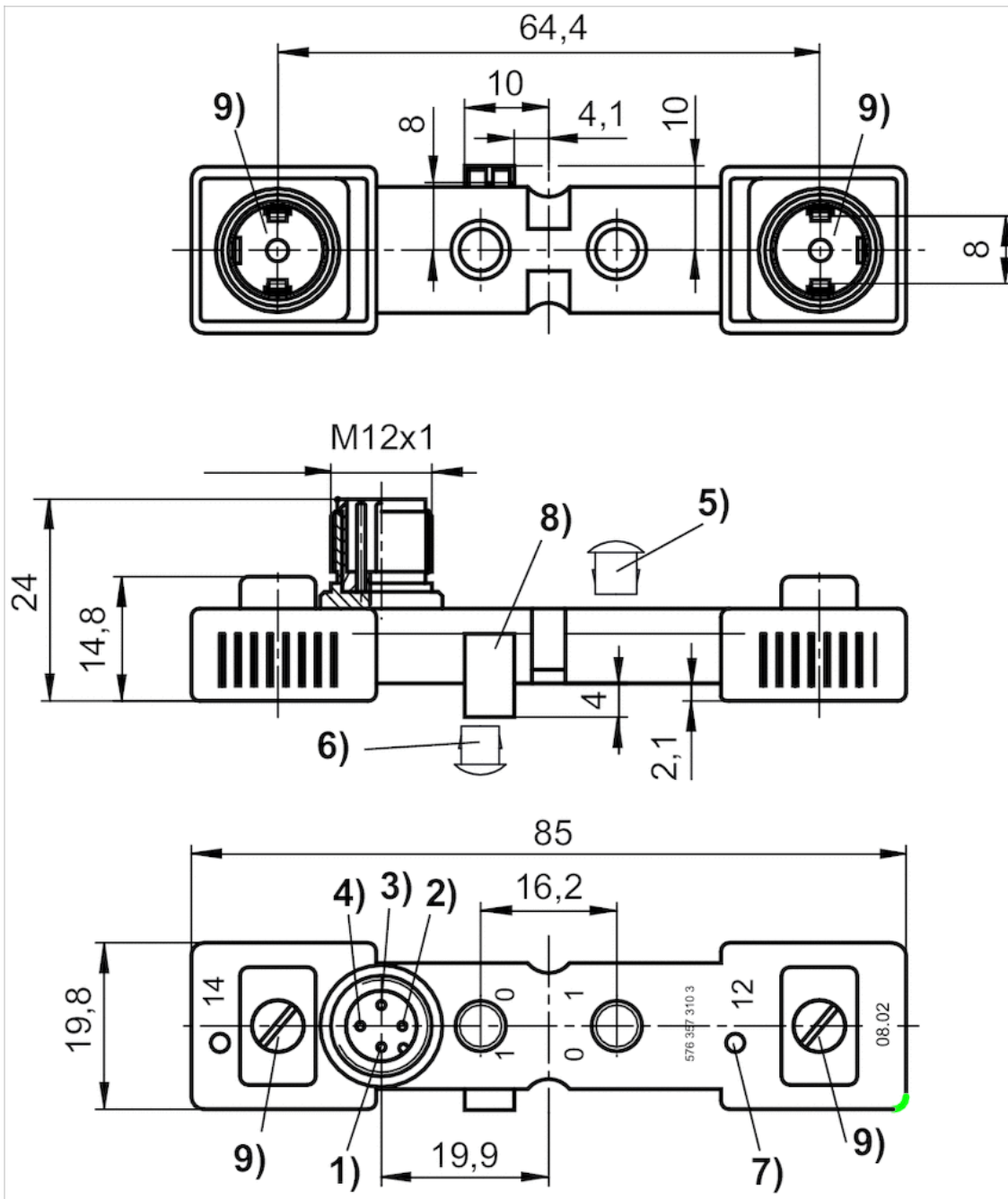

- 1) not assigned 2) solenoid 12 3) 0 V 4) solenoid 14
- 5) Sealing cap for manual override not removable
- 6) Removable
- 7) LED valve
- 8) positioning pin
- 9) captive seal and screw

Contact bridges, series CON-CB

- Plug, 4-pin, straight, 180°
- Socket, form C, 2-pin, straight
- Number of solenoid coils 1



Ambient temperature min./max.	-15 ... 50 °C
Protection class	IP65
Protective circuit	43 V bi-directional
Operational voltage	24 V DC
Valve LED status display	Yellow
Mounting screw	M2.5 with slot
Tightening torque for mounting screws [+0,05]	0.25 Nm
Weight	0.02 kg

Technical data

Part No.

R412005847

Technical information

Material

Housing	Polyester amide
Seals	Fluorocaoutchouc

Dimensions

Dimensions

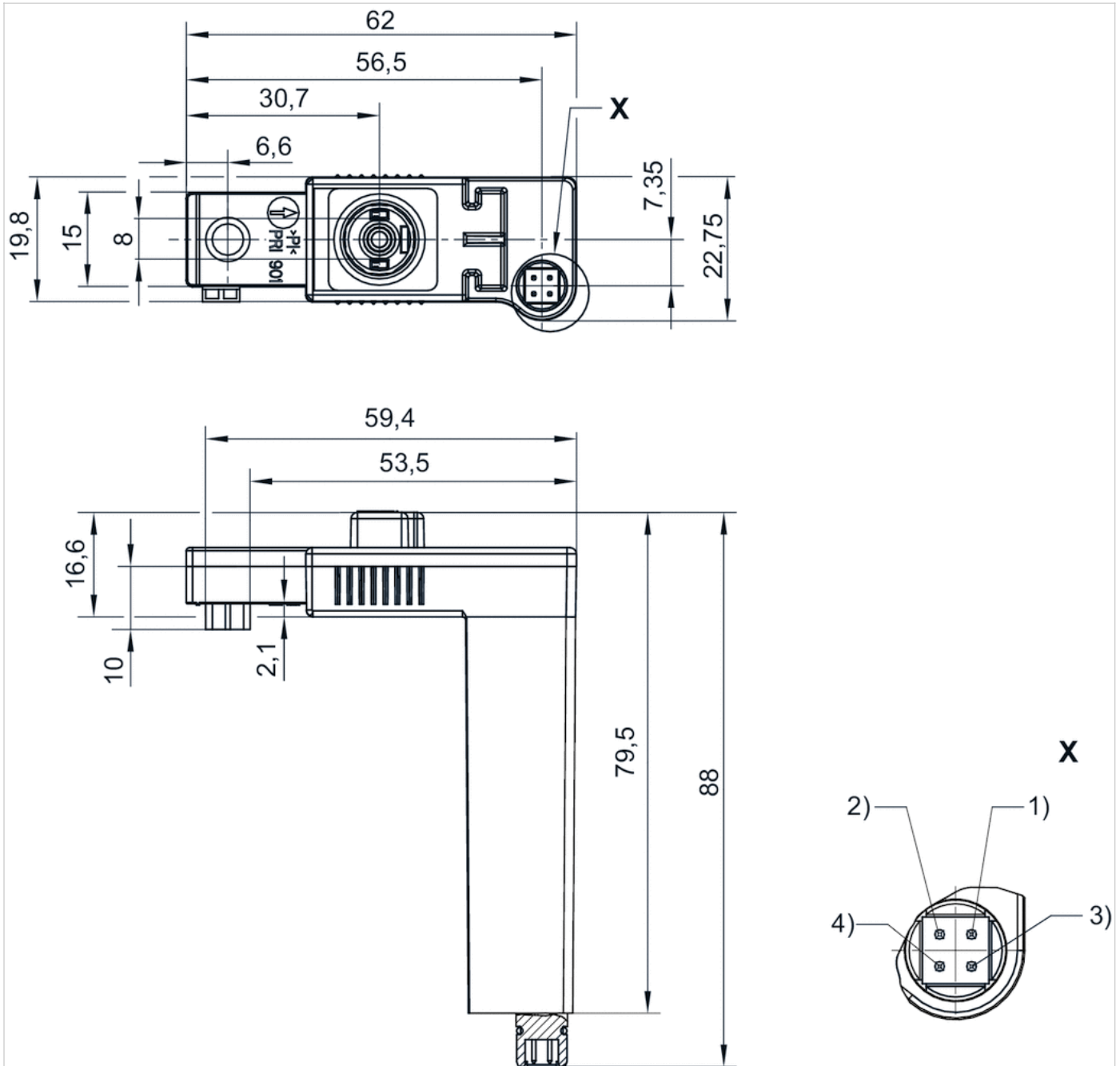

Pin assignment:
 Pin 1: solenoid 14
 Pin 2: solenoid 12
 Pin 3: ground
 Pin 4: 0 V

Contact bridges, series CON-CB

- Plug, 4-pin, straight, 180°
- Socket, form C, 2-pin, straight
- Socket, form C, 2-pin, straight
- Number of solenoid coils 2



Ambient temperature min./max.	-15 ... 50 °C
Protection class	IP65
Operational voltage	24 V DC
Valve LED status display	Yellow
Mounting screw	M2.5 with slot
Tightening torque for mounting screws [+0,05]	0.25 Nm
Weight	0.03 kg

Technical data

Part No.
R412005846

Technical information

Material	
Housing	Polyester amide
Seals	Fluorocaoutchouc

Dimensions

Dimensions

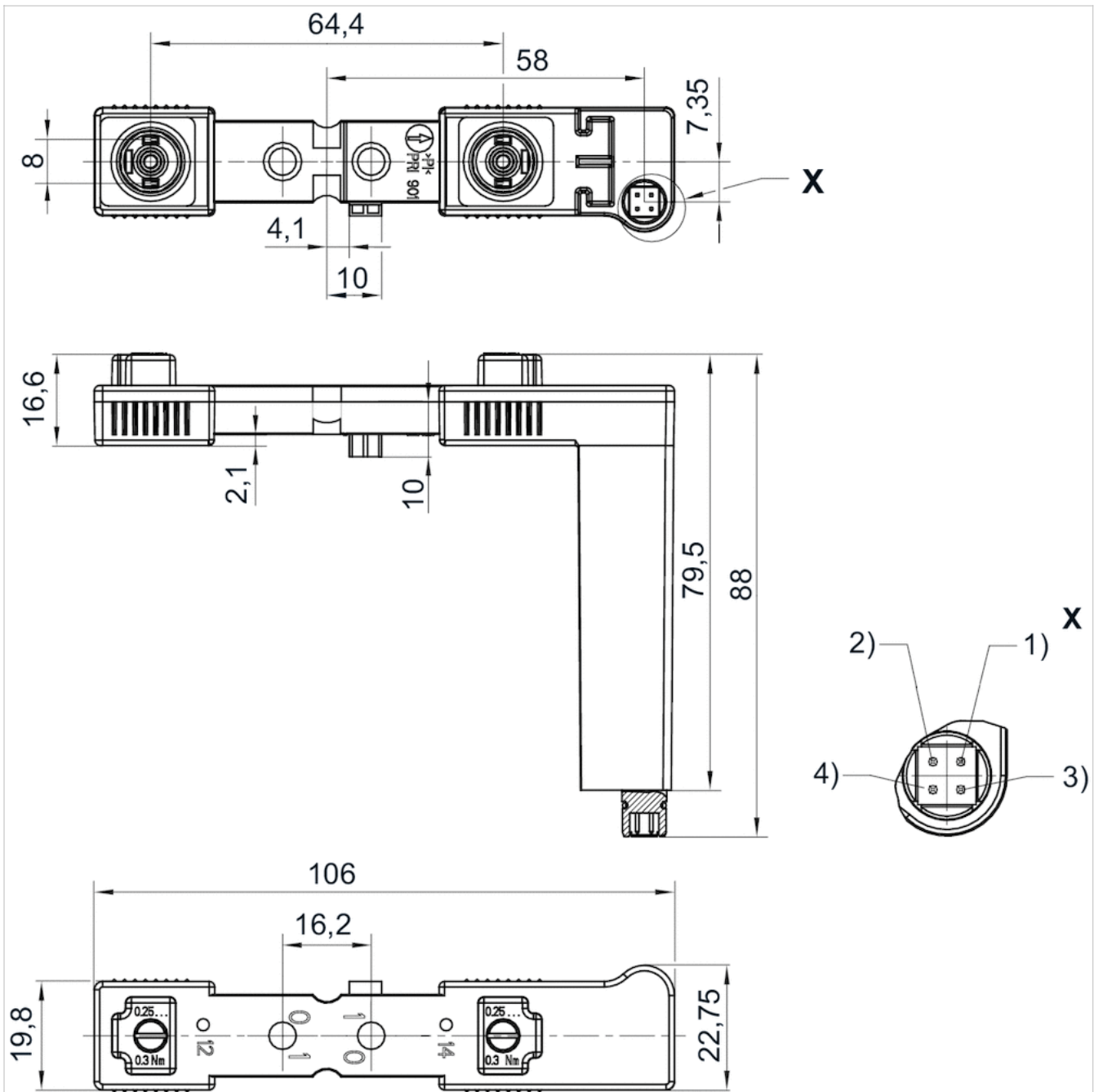

Pin assignment:

Pin 1: solenoid 14

Pin 2: solenoid 12

Pin 3: ground

Pin 4: 0 V

Contact bridges, series CON-CB

- Control Snap Ø8
- Plug, 3-pin, straight, 180°
- Socket, form C, 2-pin, straight
- Socket, form C, 2-pin, straight
- Number of solenoid coils 2



Ambient temperature min./max.	-25 ... 75 °C
Protection class	IP65
Operational voltage	24 V DC
Valve LED status display	Yellow
Mounting screw	M2.5 with slot
Tightening torque for mounting screws [+0,05]	0.25 Nm
Weight	0.019 kg

Technical data

Part No.	Wire cross-section
5763503193	0.14 mm ²

Technical information

The specified protection class is only valid in assembled and tested state.

Technical information

Material	
Housing	Polyester amide
Seals	Fluorocaoutchouc

Dimensions

Dimensions

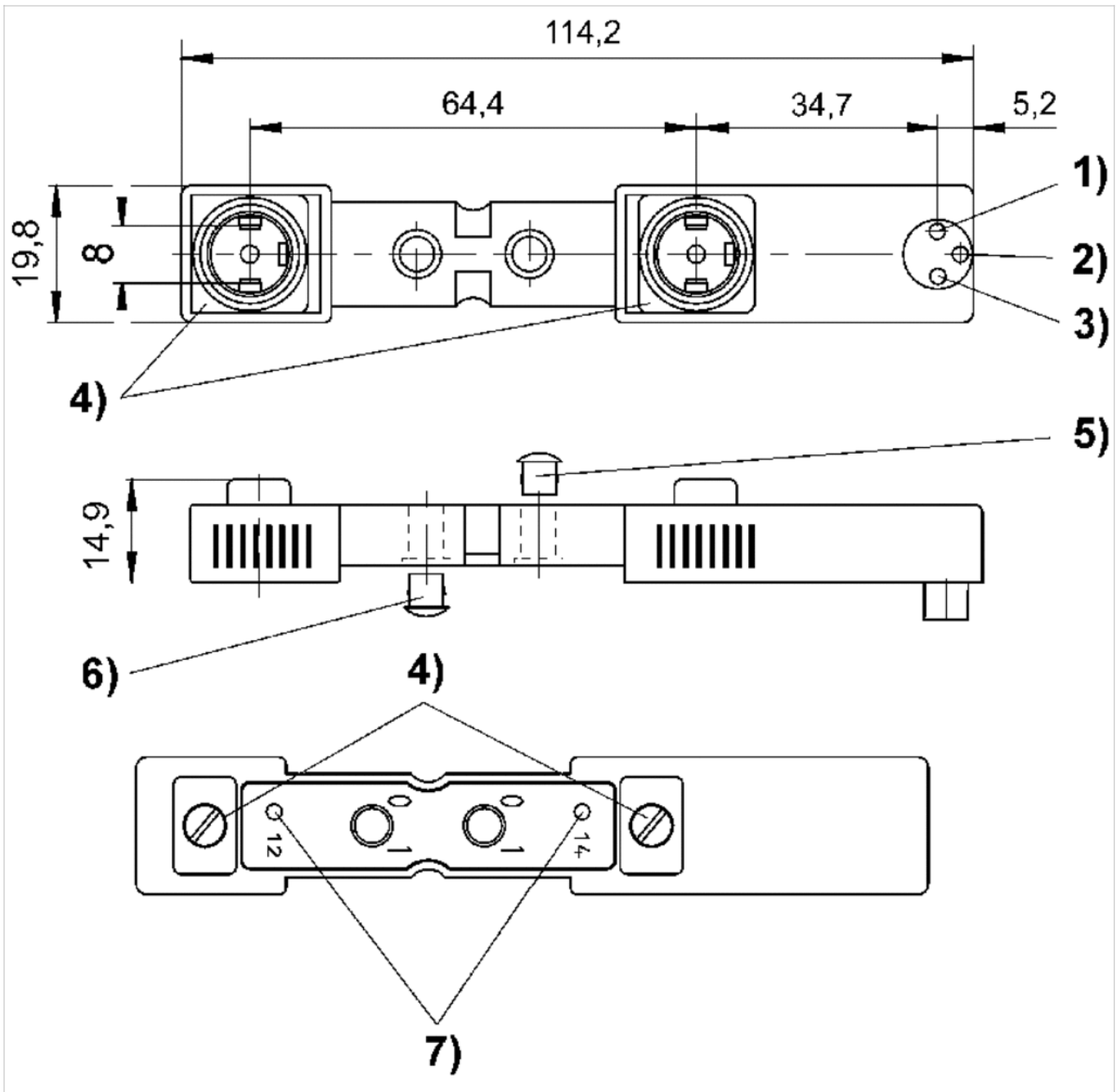

- 1) solenoid 14 2) solenoid 12 3) 0 V
- 4) captive seal and screw 5) sealing cap for manual override not removable 6) removable 7) LED valve





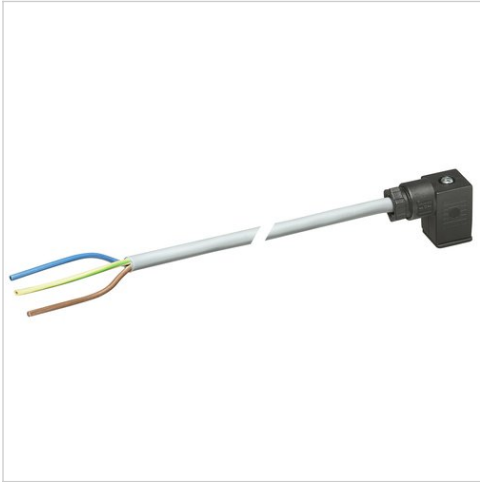





Valve plug connector, series CON-VP

- Socket form C 2+E angled 90°
- open cable ends 3-pin
- with cable
- unshielded

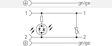
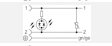

Ambient temperature min./max.	-20 ... 80 °C
Operational voltage	See table below
Protection class	IP67
Wire cross-section	0.75 mm ²
Mounting screw tightening torque	0.4 Nm
Weight	See table below

Technical data

Part No.		Operational voltage	Max. current	Protective circuit	Contact assignment
1834484212		230 V AC/DC	6 A	-	2+E
1834484213		230 V AC/DC	6 A	-	2+E
1834484214		230 V AC/DC	6 A	-	2+E
1834484215		230 V AC/DC	6 A	-	2+E
1834484204		24 V AC/DC	6 A	Z-diode	2+E
1834484205		24 V AC/DC	6 A	Z-diode	2+E
1834484206		24 V AC/DC	6 A	Z-diode	2+E
1834484207		24 V AC/DC	6 A	Z-diode	2+E
1834484208		230 V AC/DC	6 A	Varistor	2+E
1834484209		230 V AC/DC	6 A	Varistor	2+E
1834484210		230 V AC/DC	6 A	Varistor	2+E
1834484211		230 V AC/DC	6 A	Varistor	2+E
1834484236		24 V AC/DC	6 A	Z-diode	2+E

Part No.	LED status display	Number of wires	Cable-Ø	Cable length	Weight	Fig.	
1834484212	-	3	5.9 mm	3 m	0.183 kg	Fig. 1	-
1834484213	-	3	5.9 mm	3 m	0.183 kg	Fig. 2	-
1834484214	-	3	5.9 mm	5 m	0.308 kg	Fig. 1	-
1834484215	-	3	5.9 mm	5 m	0.308 kg	Fig. 2	-
1834484204	Yellow	3	5.9 mm	3 m	0.185 kg	Fig. 1	1)
1834484205	Yellow	3	5.9 mm	3 m	0.185 kg	Fig. 2	1)
1834484206	Yellow	3	5.9 mm	5 m	0.292 kg	Fig. 1	1)
1834484207	Yellow	3	5.9 mm	5 m	0.298 kg	Fig. 2	1)
1834484208	Yellow	3	5.9 mm	3 m	0.171 kg	Fig. 1	1)
1834484209	Yellow	3	5.9 mm	3 m	0.194 kg	Fig. 2	1)
1834484210	Yellow	3	5.9 mm	5 m	0.297 kg	Fig. 1	1)

Part No.	LED status display	Number of wires	Cable-Ø	Cable length	Weight	Fig.	
1834484211	Yellow	3	5.9 mm	5 m	0.285 kg	Fig. 2	1)
1834484236	Yellow	3	5.9 mm	10 m	0.571 kg	Fig. 2	1)

1) Scope of delivery incl. flat gasket

Technical information

The specified protection class is only valid in assembled and tested state.

Technical information

Material	
Seals	caoutchouc/butadiene caoutchouc
Cable sheath	Polyvinyl chloride

Dimensions

Fig. 1

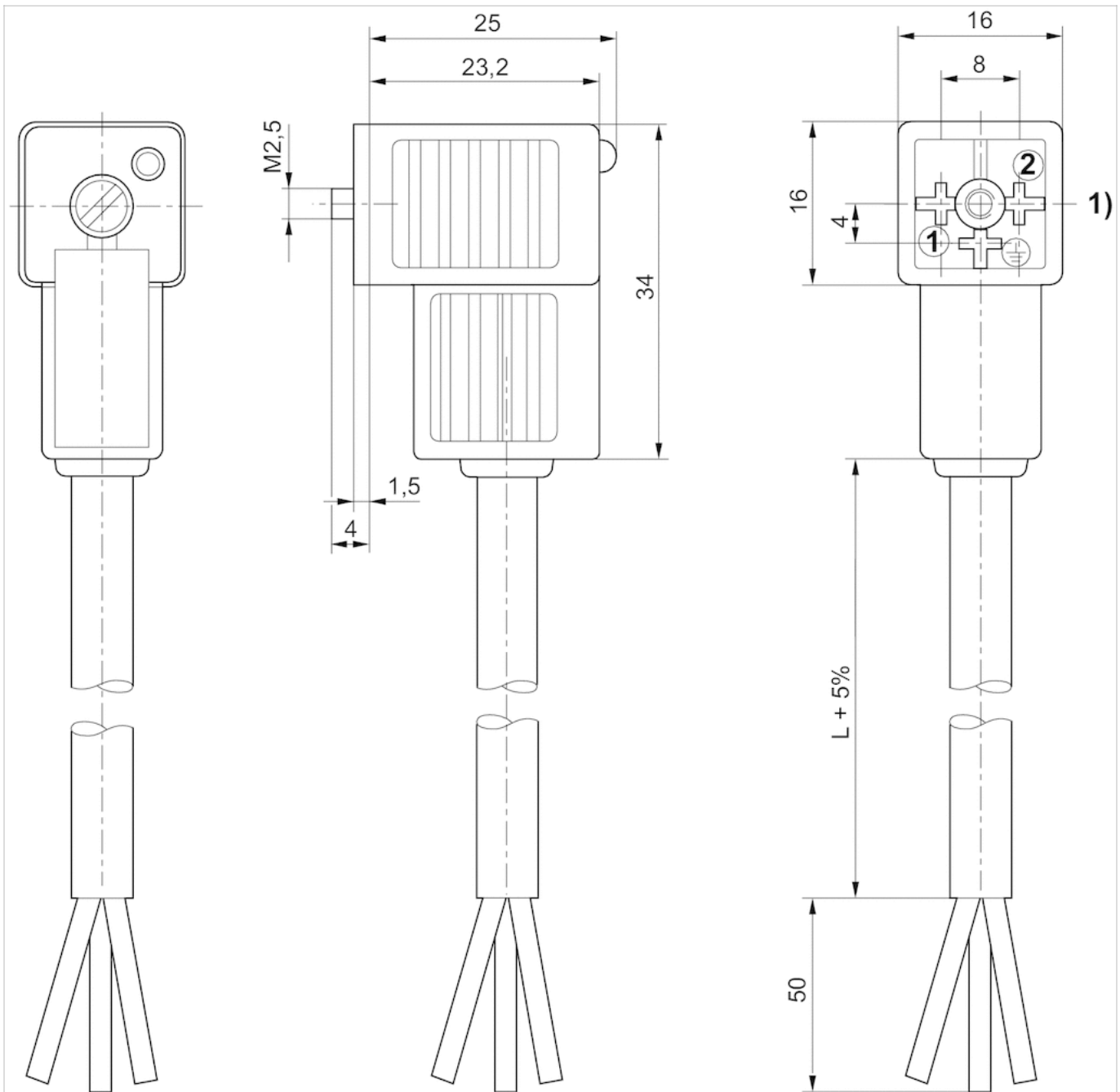

1) 0° female insert

Fig. 2

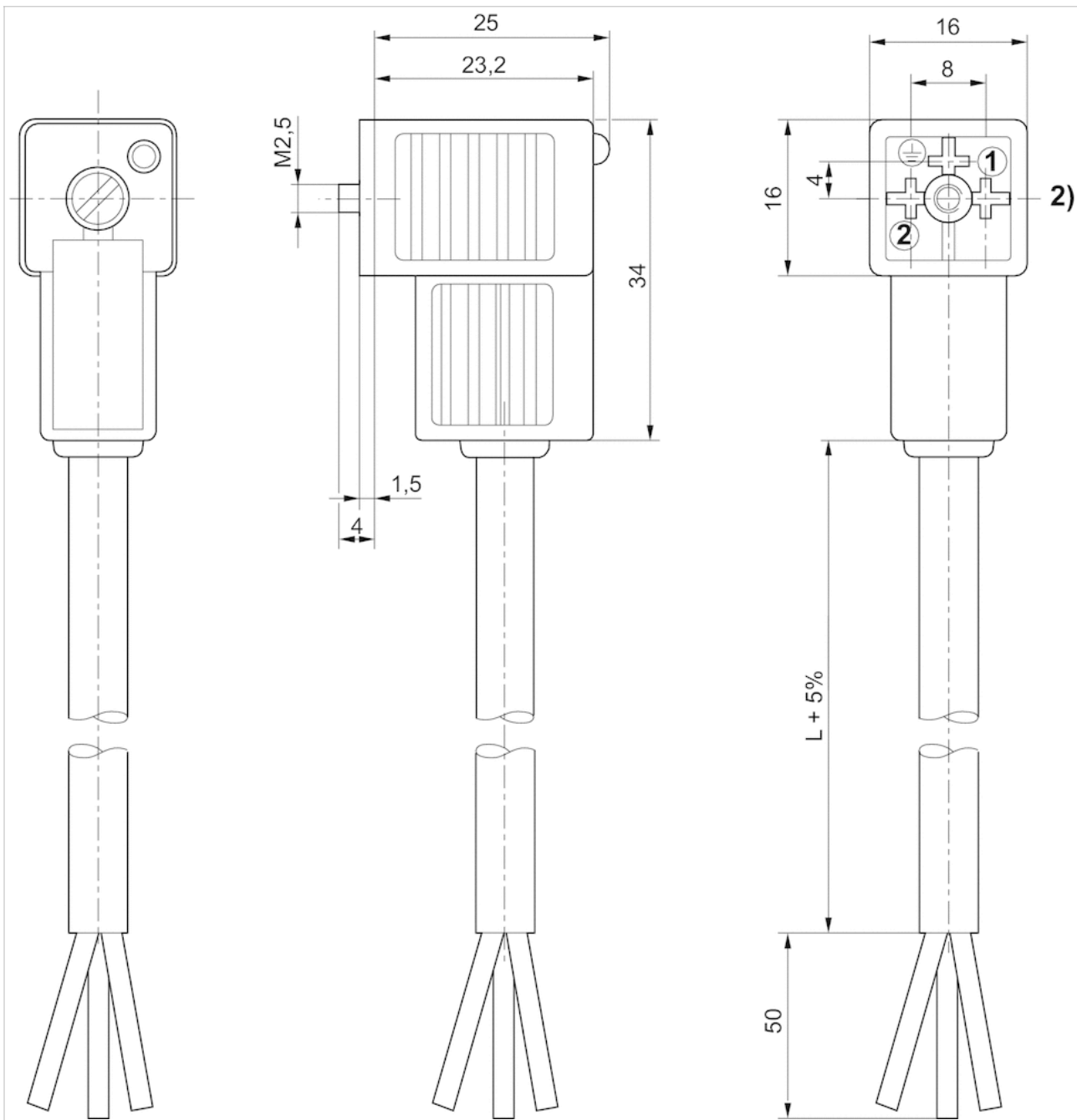

2) 180° female insert

Efficient pneumatic solutions, our program: cylinders and drives, valves and valve systems, air supply management



Visit us: Emerson.com/Aventics

Your local contact: Emerson.com/contactus



Emerson.com



[Facebook.com/EmersonAutomationSolutions](https://www.facebook.com/EmersonAutomationSolutions)



[LinkedIn.com/company/Emerson-Automation-Solutions](https://www.linkedin.com/company/Emerson-Automation-Solutions)



[Twitter.com/EMR_Automation](https://twitter.com/EMR_Automation)

An example configuration is depicted on the title page. The delivered product may thus vary from that in the illustration. Subject to change. This Document, as well as the data, specifications and other information set forth in it, are the exclusive property of AVENTICS GmbH. It may not be reproduced or given to third parties without its consent. Only use the AVENTICS products shown in industrial applications. Read the product documentation completely and carefully before using the product. Observe the applicable regulations and laws of the respective country. When integrating the product into applications, note the system manufacturer's specifications for safe use of the product. The data specified only serve to describe the product. No statements concerning a certain condition or suitability for a certain application can be derived from our information. The information given does not release the user from the obligation of own judgment and verification. It must be remembered that the products are subject to a natural process of wear and aging.

The Emerson logo is a trademark and service mark of Emerson Electric Co. Brand logotype are registered trademarks of one of the Emerson family of companies. All other marks are the property of their respective owners. © 2017 Emerson Electric Co. All rights reserved.
2019-03



CONSIDER IT SOLVED™