

NEW!

Mini 3-Finger Gripper

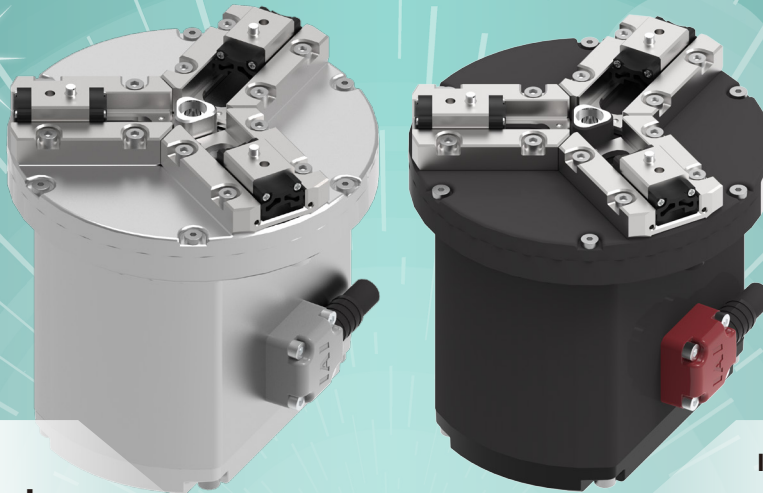

Built-in controller

ROBO CYLINDER

RCP6-GRTR9

EC ELECYLINDER®

EC-GRTR9

No tool changing!
Multi-point positioning

Ideal for replacing air cylinders
2-point positioning

Easy mounting on the tool tip due to its compact size!

Expands applications such as inspection and centering processes of workpieces.

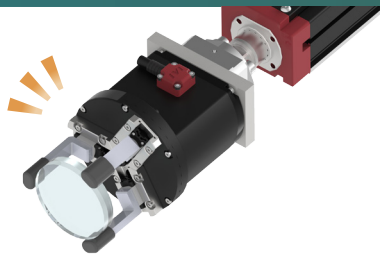

[Application Example] Inspection equipment for camera lenses

Previous model (RCP2-GR3SS)

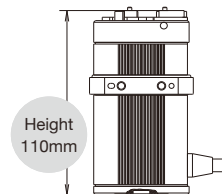

Height 110mm

NEW! EC-GRTR9 / RCP6-GRTR9

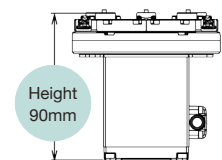

Height 90mm

Diameter Ø90mm

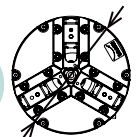

High gripping force and long stroke!

Maximum gripping force

70N

Stroke (both sides)

30mm

Three times larger than the previous model*

*RCP2-GR3SS

Electric operation allows for easy fine-tuning of speed and gripping force

Gripping force can be set in **percentage increments**. Precise adjustments to specific values enable handling of workpiece deformation.

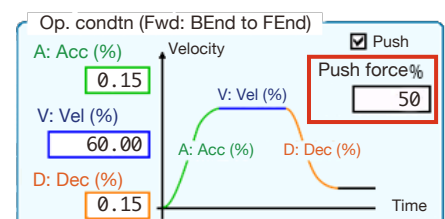

Product Specifications

ROBO CYLINDER

- ① **RCP6** - ② **GRTR9** - ③ **WA** - ④ **35P** - ⑤ **7.5** - ⑥ **30** - ⑦ - ⑧ - ()
- Series Type Encoder Motor type Reduction ratio Stroke Applicable controller Cable length Options

ELECYLINDER

- ① **EC** - ② **GRTR9** - ⑤ **M** - ⑥ **30** - ⑨ - ⑩ - ()
- Series Type Reduction ratio Stroke Actuator cable length Power-I/O cable length Options

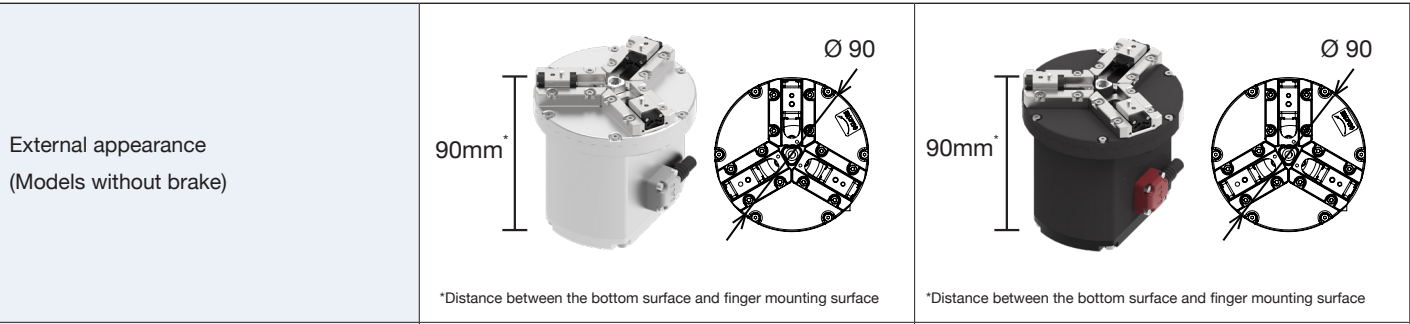

① Series	RCP6	EC
② Type	GRTR9	
③ Encoder	Battery-less absolute encoder	Incremental battery-less absolute encoder (optional)
④ Motor type	Stepper motor (<input type="checkbox"/> 35)	
⑤ Reduction ratio	7.5 (equivalent to 7.5mm lead)	M (equivalent to 7.5mm lead)
⑥ Stroke (mm)	30 (15 per finger)	
⑦ Applicable controller	P3: PCON MSEL P5: RCON RSEL	-
⑧ Cable length	N: None, P: 1m, S: 3m, M: 5m X <input type="checkbox"/> <input type="checkbox"/> : Specified length, R <input type="checkbox"/> <input type="checkbox"/> : Robot cable	-
⑨ Actuator cable length (m)	(can be changed by option)	1 to 10 (in one meter increments) *Select so that the total length of the actuator cable and power-I/O cable is 10m or less.
⑩ Power-I/O cable length (m)	-	0 (No cable) / 1 to 9, S1 to S9 *4-way connector specification if prefixed by "S" before number. *Select so that the total length of the actuator cable and power-I/O cable is 10m or less.
Max. gripping force (N) *Total of 3 fingers	70	
Max. speed (mm/s) at gripping operations *per finger	20	
Max. speed (mm/s) *per finger	85	
Min. speed (mm/s) *per finger	9.4	
Static allowable moment (N·m) *per finger	Ma:1.97/Mb2.81/Mc5.32	
Allowable load for vertical direction (N)	88.7	

IAI America, Inc.

USA Headquarters & Western Region (Los Angeles): 2690 W. 237th Street, Torrance, CA 90505 (310) 891-6015
 Midwest Branch Office (Chicago): 110 East State Parkway, Schaumburg, IL 60173 (847) 908-1400
 Southeast Branch Office (Atlanta): 1220 Kennestone Circle, Suite 108, Marietta, GA 30066 (678) 354-9470

www.intelligentactuator.com

IAI Group Headquarters and Main Factory:

1210 Iharacho, Shimizu-ku, Shizuoka-shi, Shizuoka, 424-0114, JAPAN

The information contained in this product brochure may change without prior notice due to product improvements.

IAI Industrieroboter GmbH

Ober der Röth 4,
D-65824 Schwalbach am Taunus, Germany

IAI Robot (Thailand) Co., Ltd.

825 Phairojkijja Tower 7th Floor, Debaratana Rd.,
Bangna Nuea, Bangna, Bangkok 10260, Thailand

IAI (Shanghai) Co., Ltd.

SHANGHAI JIAHUA BUSINESS CENTER A8-303,
808 Hongqiao Rd. Shanghai 200030, China