

ASCO™ Connected Solenoid Valve with Supervisory Feature

Application

Robust and smart solenoid valve used for fire suppression deluge systems. Complying with the latest NFPA13 requirements, this valve is equipped with a supervisory feature that notifies the control panel when the coil is removed or not properly installed.

Features & Benefits

- Complies with latest **NFPA13** requirements*
- **Real-time monitoring** and **instant notification** when coil is removed or not installed properly**
- Accurate detection of coil placement thanks to **physical switch**
- **Easy** and **quick** installation with **one** fully integrated solution

* NFPA 13 section 8.3.1.2.1 Actuator Supervision "Effective January 1, 2021, removal of an electric actuator from the pre-action or deluge valve that it controls shall result in an audible and visual indication of system impairment at the system releasing control panel." [NFPA 13 2019].

** Patent pending

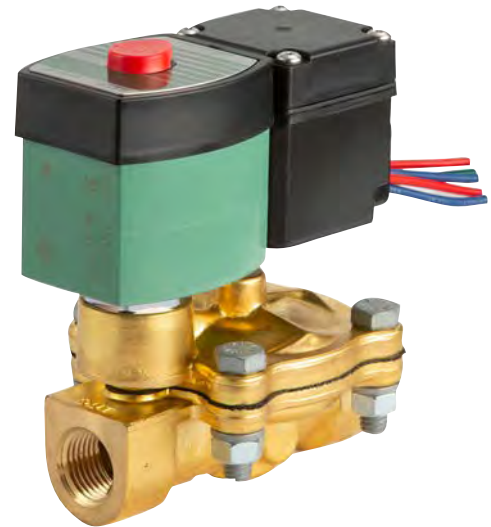

Specifications

Pipe Size (in)	1/2"
Orifice Size (in)	3/4"
Cv Flow Factor	4.0
Operating Pressure Differential (psi)	5 psi to 300 psi
Media Handled	Water
Media Temp (°F)	40°F to 130°F
Ambient Temp (°F)	40°F to 130°F
Body Material	Brass
Internal Material	Stainless Steel, Brass, NBR
Power Rating / Class of Coil Insulation	11.6W / F
Voltage	24 VDC
Approvals	<ul style="list-style-type: none"> • UL US & CANADIAN CERTIFIED, UL FILE MP618, V27, S1. • FOR US: UL429/429A, LISTED SAFETY SHUTOFF VALVE FOR FIRE PROTECTION SERVICE. • FOR CANADA: CSA139, LISTED SAFETY SHUTOFF VALVE
Valve Mounting	Any Position
Electrical Connection	Leaded (18" length)
Surveillance Switch Max Electrical Rating	30 VDC @ 250mA
Catalog number	X210554928001F1

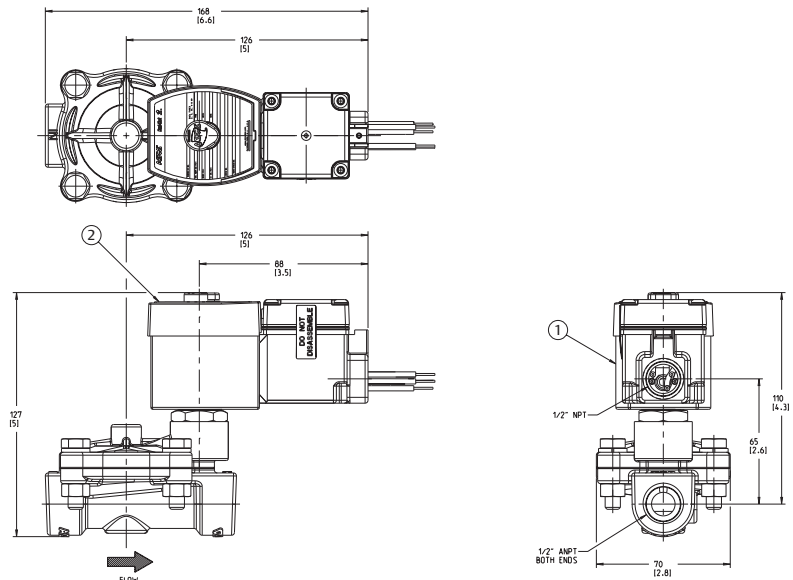

NOTES:

- ① All dimensions are for reference only.
- ② Qualified for fire protection special system water control valve release service (UL429A) and is complementary listed in the fire protected equipment directory for product category accessories for special systems (VLTR) electrically operated "actuating valve".

For more information:
www.Emerson.com/ASCO

ASCO™

EMERSON™