

EWP-R SERIES SPECIFICATIONS

Engineered for both reliability and versatility, the **EWP-R** offers programmable analog and digital pulse input control in a fully featured control unit.

With 1800:1 turndown ratio and high-speed 360 strokes-per-minute operation, the EWP-R ensures consistent high-resolution performance. The backlit LCD and a large multicolor LED provide clear indication of display and operational status. Advanced control, high turndown, robust priming capability and durable construction make it the optimal choice for any cost-effective, high-precision chemical injection application.

Flowrates up to 6.7 GPH (25 l/h) and pressure capability to 300 psi (20 bar) enable the EWP-R to maximize value in most chemical delivery applications.

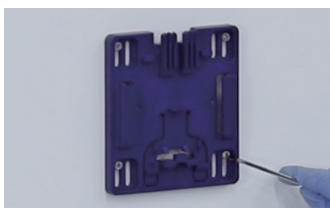

Flexible Installation

Quick-access mounting base enables the EWP-R to be easily wall mounted or quickly removed from an installation without the need for tools.

Rugged Housing

The EWP Series pumps are sealed and rated to an IP66 protection class (water and dust-proof) even without the chemical splash guard.



WALCHEM

IWAKI America Inc.

EWP MODEL IDENTIFICATION

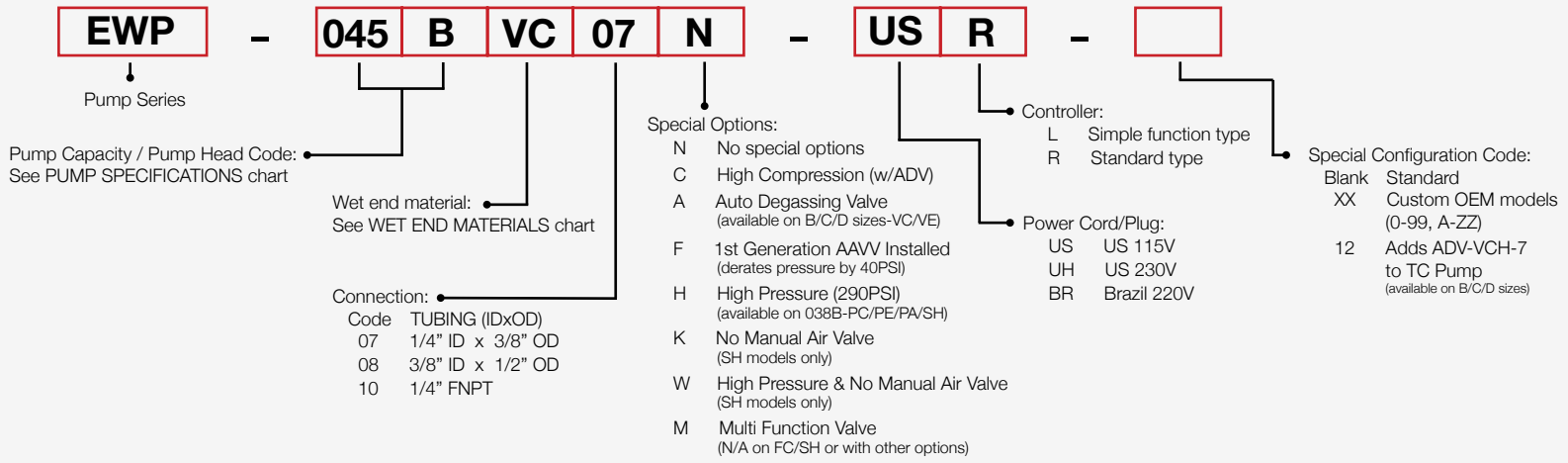

PUMP SPECIFICATIONS

	Pump Capacity	Pump Head Code	Capacity		Pressure		Special Options	MAX SPM	Wet End
			mL/Min	GPH	MPa	PSI			
Standard Models	025	A	25	0.4	1.2	175	N	360	VC/VE/VF
	045	B	45	0.7	1.0	150	N/F	360	VC/VE/VF/PC/PA PE/FC/TC/SH
	075	C	75	1.2	0.7	105	N/F	360	
	125	D	125	2.0	0.4	60	N/F	360	
	265	E	265	4.2	0.2	30	N	360	
	080	C	80	1.3	1.0	150	N/F	360	
	130	D	130	2.0	0.7	105	N/F	360	
	270	E	270	4.3	0.35	50	N	360	
	420	F	420	6.7	0.2	30	N	360	VC/VE/VF/PC/PA/PE
420	F	410	6.5	0.2	30	N	360	TC/FC/SH	
High Compression (with ADV)	020	B	20	0.3	1.0	150	C	180	VC/VE
	043	C	43	0.7	1.0	150	C	180	
	062	D	62	1.0	0.7	105	C	180	
High Pressure	038	B	38	0.6	2.0	290	H	360	PC/PE/PA/SH
Auto-Degassing Valve	035	B	35	0.6	1.0	150	A	360	VC/VE
	055	C	55	0.9	0.7	105	A	360	
	085	D	85	1.4	0.4	60	A	360	
	064	C	64	1.0	1.0	150	A	360	
	110	D	110	1.7	0.7	105	A	360	

WET END MATERIALS

Code	Pump Head	Valve Balls	Valve Seat	O-ring	Gasket	Diaphragm	
VC	PVC	CE	FKM	FKM	PTFE	PCTFE (bonded to EPDM)	CE Alumina ceramic FKM Fluoroelastomer PTFE Polytetrafluoroethylene PVDF Polyvinylidene Fluoride EPDM Ethylene propylene diene monomer GFRPP Glass Fiber Reinforced Polypropylene PVC Polyvinylchloride (translucent) HC Hastelloy C276 316SS Stainless Steel AFLAS Ethylene propylene diene monomer
VE			EPDM	EPDM			
VF		PTFE					
PC	GFRPP	CE	FKM	FKM			
PE			EPDM	EPDM			
PA			PCTFE	AFLAS			
TC			FKM	FKM			
TA	PVDF	CE	PCTFE	AFLAS			
FC				—			
SH				316SS	316SS		



The EWP metering pumps are tested by Intertek to UL and CSA standards.

CONTROLLER SPECIFICATIONS

Controller type		EWP-R	
Operation mode	MAN	0.1–100% stroke rate ^{Note1} (1–360 spm)	
	EXT	ANA.P (Analogue preset)	4–20, 0–20, 2 0–4, 20–0 mA (Proportional operation with stroke rate)
		ANA.V (Analogue variable)	2 points setting (proportional operation with flow rate or stroke rate) Setting range: 0.0–20.0 mA, 0–Max. flow rate or 0.0–100% stroke rate
		PLS.V (Pulse variable)	2 points setting (proportional operation with flow rate or stroke rate) Setting range: 0.0–500 Hz, 0–Max. flow rate or 0.0–100% stroke rate
		DIV (Dividing)	/1–9999
		MULTI (Multiply)	×1–9999
		BATCH (Batch operation)	0.1 mL–99.9999 L (0.0001–26.4199 Gal)
INT.B (Interval batch operation)	0–9 Days, 0–23 Hours, 0–59 Minutes Flow rate: 0.1 mL–99.9999 L (0.0001–26.4199 Gal)		
Operational panel	LCD	14seg 5digits, 7seg 4digits, backlight LCD	
	Status LED	White	Lights when the pump is in the wait state or menu mode.
		Green	Blinks synchronously with stroke when the pump is running.
		Orange	Blinks synchronously with stroke when the Pre-STOP signal is input.
		Purple	Lights when the STOP signal is input.
Red		Lights when the Interlock signal is input.	
Control functions	STOP/Pre-Stop	Pump keeps running during Pre-STOP signal input. Pump stops when STOP signal input. ^{Note2}	
	PRIME	Max. spm operation while holding down the START/STOP key.	
	Keypad lock	PIN number entry disables the function.	
	Interlock	Pump stops at contact input.	
	AUX	Pump runs at the preset AUX speed.	
	Buffer memory	MULTI/DIV: Excess pulse signal can be stored up to 65535 shots. ON/OFF is selectable. BATCH: Accumulates the flow volume up to 99.9999 L. ON/OFF is selectable.	
	Current value indication	An input current is displayed during operation in the ANA.V/ANA.P mode.	
Other features	Calibration	Automatically calculates the output capacity per shot and displays the flow rate.	
	Maximum flow rate setting	Stroke rate: 0.1–100.0%, 1–360 spm	
	AUX flow rate setting	Stroke rate: 0.1–100.0%, 1–360 spm	
	Anti-Chattering	The pulse recognition time for pump not to be adversely affected by chattering or noise is selectable.	
	Logic	"Normally Open" or "Normally Closed" is selectable for input and output signal.	
	Units	mL/m, L/h and GPH each can be enabled or disabled.	
	Data Logging	Total flow volume, Total shots, OUT1 ON times, Total power-on time, operation time, Software version.	
Input	Pulse ^{Note3}	Dry contact or open collector. ^{Note4}	
	Analogue	0–20 mADC (Input resistance 220 Ω)	
	STOP/Pre-stop (Level sensor)	Dry contact or open collector ^{Note4} , 2-steps contact	
	AUX	Dry contact or open collector ^{Note4}	
	Interlock	Dry contact or open collector ^{Note4}	
Output	OUT 1	Open collector (Photo coupler) 24 VDC, 30 mA Enable or disable the alarms of spm (Synchronous with stroke), STATE (Outputs while running), STOP, Pre-STOP, I.LOCK (Interlock), B.COMP (Batch complete)	
	Auxiliary DC power	12 VDC, 30 mA	
Power Voltage	100–240 VAC 50/60 Hz ^{Note5}		

Note 1: When using Digital control (Mult/DIV), the pump's maximum stroke rate is limited to the stroke rate setting in the MAN mode (even if the Mult/DIV calculates the pump faster).

Note 2: Stop/Pre-Stop input can be selected NO/NC .

Note 3: Pulse input default frequency setting is 100Hz (Duty cycle: 50%). Max frequency limit varies based on pulse input on-time (anti-chattering). 500Hz range can only be input when selected in PLS.V mode.

Note 4: The maximum applied voltage to the contact is 5 VDC at 2.3 mA. The minimum application load of the relay or switch should be 1 mA or below.

Note 5: The allowable power voltage range is 90–264 VAC.



ELECTRICAL SPECIFICATIONS

EWP-R

50/60 Hz, single phase
115 VAC ±10%
230 VAC ±10%

EWP-R (B)

13 Watt avg.
0.8 Amp max.
0.4 Amp max

EWP-R (C-F)

23 Watt avg.
1.1 Amp max.
0.5 Amp max.

SHIPPING WEIGHT

Approx. 9 lbs. (4.1 kg)
(Plastic liquid ends)

Approx. 11 lbs. (5 kg)
(Stainless Steel liquid ends)

OPERATING CONDITIONS

Ambient Temperature: 32 to 122°F (0 to 50°C)

Liquid Temperature: PVC liquid ends: 32 to 104°F (0 to 40°C)
PP, PVDF, SS liquid ends: 32 to 140°F (0 to 60°C)
Below 32°F (0°C), pump is limited to 70% of maximum pressure.
Liquid cannot freeze.

Relative Humidity: 30% to 90% non-condensing

Pumps should always be shielded from direct exposure to the elements.

EWP-R

Dimensions in mm

(VC/VS/VE/PC/PS/PE/TC)

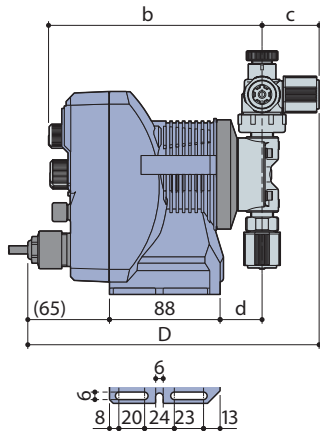

(FC)

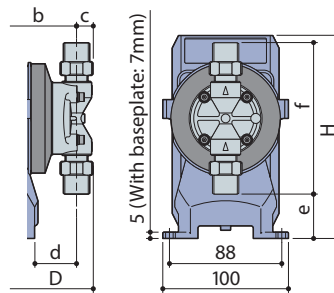

(SH)

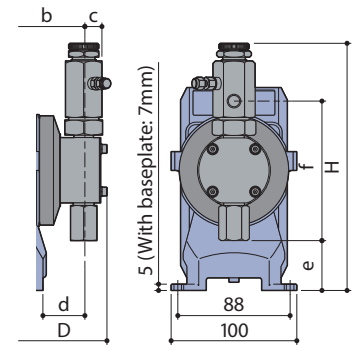

• Illustration shows 038B, 080C, 130D
• The EWP-SH type is heavy, so a base plate is used.
With baseplate: 7mm

(VC/VS/VE/PC/PS/PE/TC)

Model	(H)	(D)	(a)	(b)	(c)	(d)	(e)	(f)
EWP-038B								
EWP-080C	194	233		170	47	33	20	139
EWP-130D			—					
EWP-270E	207	235		172	47	35	4	168
EWP-420F	206			171			5	166

(FC)

Model	(H)	(D)	(a)	(b)	(c)	(d)	(e)	(f)
EWP-038B								
EWP-080C	162	199		170	13	33	35	121
EWP-130D			—					
EWP-270E				172				
EWP-410F	173	204		171	16	35	19	154

(SH)

Model	(H)	(D)	(a)	(b)	(c)	(d)	(e)	(f)
EWP-038B								
EWP-080C	197	204		170	15	32	40	111
EWP-130D			—					
EWP-270E	209	205		170	15	34	30	133
EWP-410F	211	207					27	138

Notes:

- The Multifunction valve increases the overall length (D) by 2.5mm, the discharge height (f) by 66.5mm, and the overall height (H) by 31.8mm.
- The Auto-Degassing valve increases the overall height (H) and the discharge height (f) by 45.9mm

180967.D
ISO 9001 registered company

WALCHEM

IWAKI America Inc.

Walchem integrates its advanced sensing, instrumentation, fluid pumping and communications technologies to deliver reliable and innovative solutions to the global water treatment market. Our in-house engineering is driven by quality, technology and innovation. For more information on the entire Walchem product line, visit: walchem.com