

Vibrating level switch

For the process industry

Models TLS-SA, TLS-SAD

WIKA data sheet LM 30.10



For further approvals,
see page 5

Applications

- General purpose vibrating level switch designed to suit all liquids
- Particularly suitable as overflow and dry run protection of pumps, vessels and pipelines
- For use in the petroleum, chemical, water/wastewater, food, beverage and pharmaceutical industries

Special features

- Robust design for the process industry
- Explosion-protected version
- Low maintenance costs
- Stable and reliable level detection, unaffected by flow, bubble formation, vibrations, build-up or solids in the medium



Vibrating level switch, model TLS

Description

The core element of the vibrating level switch is the vibrating fork with integrated vibration drive. When the vibrating tuning fork is immersed in the medium, the resonance frequency of the tuning fork decreases. The frequency change is detected by the electronic circuit and is converted to a switching signal. Irrespective of the mounting position, level changes can be detected very accurately.

The respective switch point can be changed via a pipe extension. The high switch point accuracy can be individually adjusted to the respective application using ten sensitivity levels. It is also possible to set a switching delay of 1 ... 20 seconds with the model TLS-S. For use in hazardous areas, explosion-protected versions are also available.

The vibrating level switches are, depending on the version, suitable for an operating temperature of $-100 \dots +200 \text{ }^{\circ}\text{C}$ [$-148 \dots +392 \text{ }^{\circ}\text{F}$] and an operating pressure of $-1 \dots +100 \text{ bar}$ [$-14 \dots +1,450 \text{ psi}$]. The vibrating level switch is suitable for media with a density of $500 \dots 2,500 \text{ g/cm}^3$ [$289 \dots 1,445 \text{ oz/in}^3$]. The viscosity of the media should be between 0.1 and 10,000 cP [0.24 and 21,190 lb/ft-h].

Application example

In practice, the vibrating level switches are mainly used in two areas: Firstly, the level switches are used to detect and control high and low levels in liquid vessels. Secondly, the vibrating level switches are used to detect liquids in pipelines to prevent the pump from running dry.

Level detection for vessels

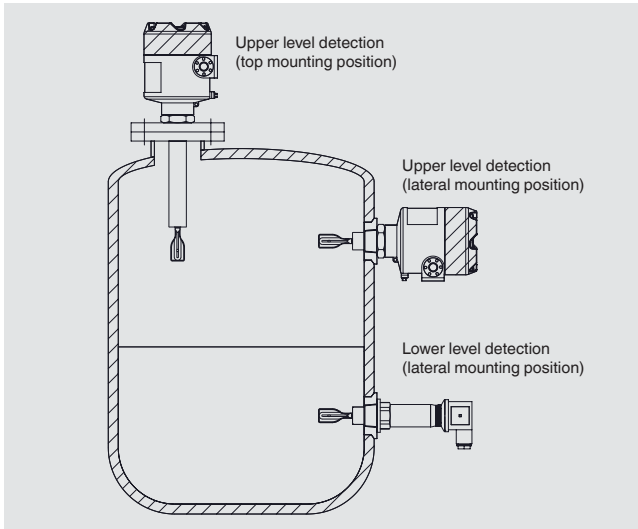

The vibrating level switch is usually installed on the side of the tank to detect the upper and lower liquid levels. If the vessel has no side openings, the limit level switch can also be mounted on the tank from above. A pipe extension is then often used to achieve the desired switch point. Installation on the underside of the tank is also possible.

Pipeline monitoring

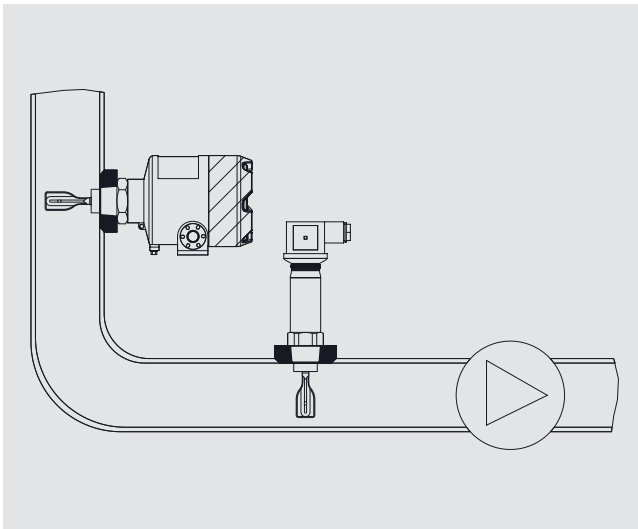

To ensure that a pump does not run dry, there must be sufficient liquid in the intake pipe. The vibrating level switch can detect this and thereby prevent damage to the pump. Since the tuning fork only protrudes 38 mm [1.5 in] into the pipeline, it can be used to measure in small diameter pipelines.

Overview of versions

Model	Description
TLS-SA	Vibrating level switch, without Ex
TLS-SAD	Vibrating level switch, with Ex d approval

Vibrating level switch TLS-S, also available in Ex version

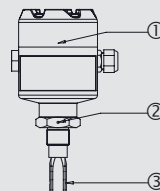
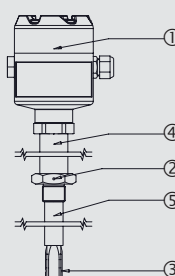
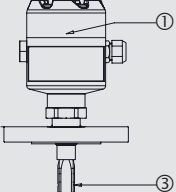
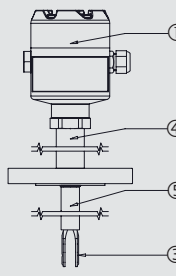
	Mounting thread	Mounting thread with cooling element and extension	Flange version	Flange version with cooling element and extension
① Connection housing ② Direction mark ③ Switch point ④ Cooling element ⑤ Extension				
Connection housing	90 x 125 mm [3.54 x 4.92 in]			
Electrical connection				
Cable gland	<ul style="list-style-type: none"> ■ M20 x 1.5 ■ 1/2" NPT ■ 3/4" NPT 			
Cable bushing	<ul style="list-style-type: none"> ■ M20 x 1.5 ■ 1/2" NPT ■ 3/4" NPT 			
Process connection	<ul style="list-style-type: none"> ■ G 3/4" ... 2" ■ 3/4" ... 2" NPT 		<ul style="list-style-type: none"> ■ DN25 ... DN100 per DIN EN 1092-1 ■ 1" ... 4" per ASME B16.5 	
Material				
Connection housing	Aluminium			
Wetted parts	<ul style="list-style-type: none"> ■ Stainless steel 1.4404 (316L) ■ Stainless steel 1.4404, 14435 (316L), electropolished ■ Stainless steel 1.4404 (316L) with PFA coating ■ Stainless steel 1.4404 (316L) with ECTFE coating ■ Hastelloy C-276 ■ Hastelloy C-276, electropolished 			
Ambient temperature	-40 ... +60 °C [-40 ... +140 °F]			
Supply voltage	DC 24 V			
Process temperature	-40 ... +150 °C [-40 ... +302 °F]	-40 ... +200 °C [-40 ... +392 °F]	-40 ... +150 °C [-40 ... +302 °F]	-40 ... +200 °C [-40 ... +392 °F]
Density of the medium	≥ 500 ... 2,500 kg/m ³			
Operating pressure	-1 ... +100 bar [-14.5 ... +1,450 psi]			
Switching delay	1 ... 20 seconds (adjustable)			
Sensitivity setting	1 ... 10 steps (adjustable)			
Switching output	<ul style="list-style-type: none"> ■ DPDT relay output ■ PNP transistor output ■ NAMUR 			
Power consumption	< 1 W			
Max. switching power (relay output)	DC 30 V / 5 A			
IP ingress protection	IP66/68			
Insertion length	76 mm [3.0 in]	76 ... 6,000 mm [3.0 ... 236.22 in]	60 mm [2.36 in]	60 ... 6,000 mm [2.36 ... 236.22 in]
Switch point calculation	Switch point = insertion length - 13 mm [0.51 in]			
Tuning fork length	<ul style="list-style-type: none"> ■ 42 mm [1.65 in] ■ 38 mm [1.50 in] 			

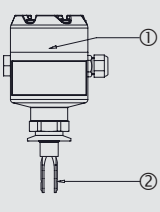
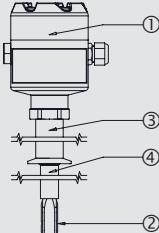
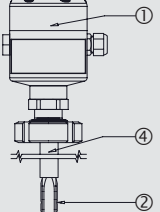
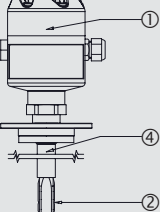
	Clamp connection	Clamp connection with cooling element and extension	DIN 11851 food-compliant process connection	DRD65 food-compliant process connection
① Connection housing ② Switch point ③ Cooling element ④ Extension				
Connection housing	90 x 125 mm [3.54 x 4.92 in]			
Electrical connection				
Cable gland	<ul style="list-style-type: none"> ■ M20 x 1.5 ■ ½" NPT ■ ¾" NPT 			
Cable bushing	<ul style="list-style-type: none"> ■ M20 x 1.5 ■ ½" NPT ■ ¾" NPT 			
Process connection	1" ... 4" per ASME BPE		DN20 ... DN100	DRD65
Material				
Connection housing	Aluminium			
Wetted parts	<ul style="list-style-type: none"> ■ Stainless steel 1.4404 (316L) ■ Stainless steel 1.4404, 14435 (316L), electropolished ■ Stainless steel 1.4404 (316L) with PFA coating ■ Stainless steel 1.4404 (316L) with ECTFE coating ■ Hastelloy C-276 ■ Hastelloy C-276, electropolished 			
Ambient temperature	-40 ... +60 °C [-40 ... +140 °F]			
Supply voltage	DC 24 V			
Process temperature	-40 ... +150 °C [-40 ... +302 °F]	-40 ... +200 °C [-40 ... +392 °F]	<ul style="list-style-type: none"> ■ -40 ... +150 °C [-40 ... +302 °F] ■ -40 ... +200 °C [-40 ... +392 °F] with cooling element 	<ul style="list-style-type: none"> ■ -40 ... +150 °C [-40 ... +302 °F] ■ -40 ... +200 °C [-40 ... +392 °F] with cooling element
Density of the medium	≥ 500 ... 2,500 kg/m ³			
Operating pressure	-1 ... +100 bar [-14.5 ... +1,450 psi]			
Switching delay	1 ... 20 seconds (adjustable)			
Sensitivity setting	1 ... 10 steps (adjustable)			
Switching output	<ul style="list-style-type: none"> ■ DPDT relay output ■ PNP transistor output ■ NAMUR (8.2 V) 			
Power consumption	< 1 W			
Max. switching power (relay output)	DC 30 V / 5 A			
IP ingress protection	IP66/68			
Insertion length	<ul style="list-style-type: none"> ■ 60 mm [2.36 in] ■ 43 mm [1.69 in] ■ 47 mm [1.85 in] 	60 ... 6,000 mm [2.36 ... 236.22 in]	60 mm [2.36 in]	60 ... 6,000 mm [2.36 ... 236.22 in]
Switch point	Switch point = insertion length - 13 mm [0.51 in]			
Tuning fork length	<ul style="list-style-type: none"> ■ 42 mm [1.65 in] ■ 38 mm [1.50 in] 			
Surface roughness (wetted)	<ul style="list-style-type: none"> ■ Ra ≤ 0.76 μm ■ Ra ≤ 0.38 μm 			

Wiring scheme

→ For details on the wiring scheme, see the model TLS installation and operating instructions, article number 14639448

TLS-S

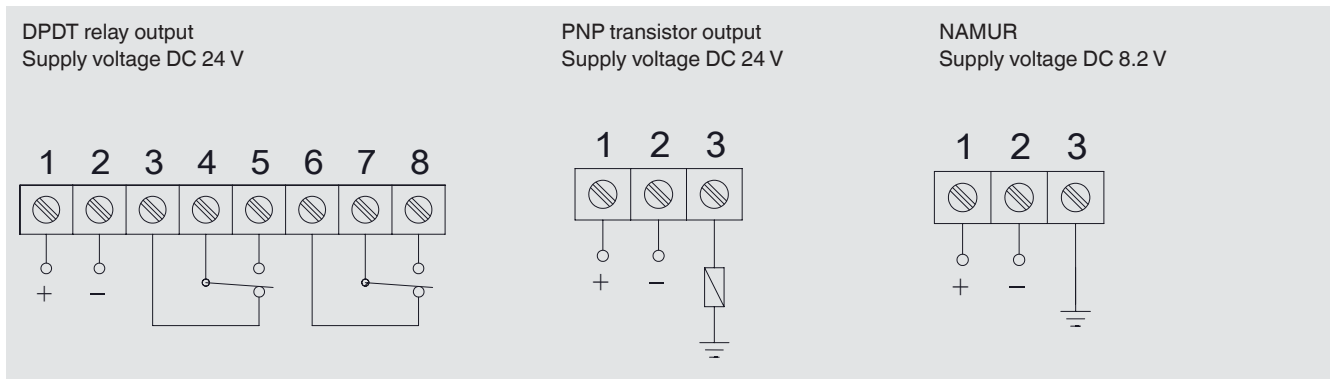

Approvals

Logo	Description	Region
	EU declaration of conformity	European Union
	EMC directive EN 61326 emission (group 1, class B) and immunity (industrial environments)	
	RoHS directive	
	UKCA	United Kingdom
	Electromagnetic compatibility regulations	
	Restriction of hazardous substances (RoHS) regulations	

Optional approvals

Logo	Description	Region
	EU declaration of conformity	European Union
	ATEX directive Hazardous areas - Ex d Zone 1 gas II 1/2G Ex db IIC T3...T6 Ga/Gb	
	IECEx Hazardous areas - Ex d Zone 1 gas Ex db IIC T6 ... T3 Ga/Gb	International
	NEPSI Hazardous areas - Ex d Zone 1 gas Zone 1, dust - Ex i Zone 0 gas Zone 1, dust Ex d IIC T3...T6 Gb Ex tb IIIC T85°C ... T200°C Db Ex ia IIC T3...T6 Ga Ex ib IIIC T85°C ... T200°C Db	China

Certificates (option)

Certificates	
Certificates	<ul style="list-style-type: none"> ■ 2.2 test report per EN 10204 (e.g. state-of-the-art manufacturing, material proof) ■ 3.1 inspection certificate per EN 10204 (e.g. material proof for wetted metal parts)

Ordering information

Model / Operating pressure / Operating temperature / Material / Electrical connection / Process connection / Switching output / Insertion length

© 10/2023 WIKA Alexander Wiegand SE & Co. KG, all rights reserved.
The specifications given in this document represent the state of engineering at the time of publishing.
We reserve the right to make modifications to the specifications and materials.
In case of a different interpretation of the translated and the English data sheet, the English wording shall prevail.



WIKA Alexander Wiegand SE & Co. KG
Alexander-Wiegand-Straße 30
63911 Klingenberg/Germany
Tel. +49 9372 132-0
info@wika.de
www.wika.de