



Bypass level indicators | Valves | Accessories | Service

Tailor-made level solutions for the process industry



Smart in sensing

Distributed by Valin Corporation | www.valin.com | (800) 774-5630 | customerservice@valin.com

100 % tailor-made

WIKA level measurement solutions are individually tailored to your process requirements and support you in operating your plant more efficiently.

In line with the international standards ASME B31.3/AD2000/EN 13445/Norsok, we offer you the possibility of almost unlimited combinations with a wide range of corrosion-resistant stainless steel and special materials.

➔ Materials

- 316/316L (1.4401/1.4404)
 - 316 Ti (1.4571)
 - Titan 3.7035
 - UNS S31254 (6Mo 1.4547)
 - Hastelloy C276 (2.4819)
 - Alloy 625 (UNS N06625)
 - Alloy 825 (UNS N08825)
 - Monel 400
 - Internal coating PTFE / E-CTFE
 - PP / PVDF
- Further materials are possible.

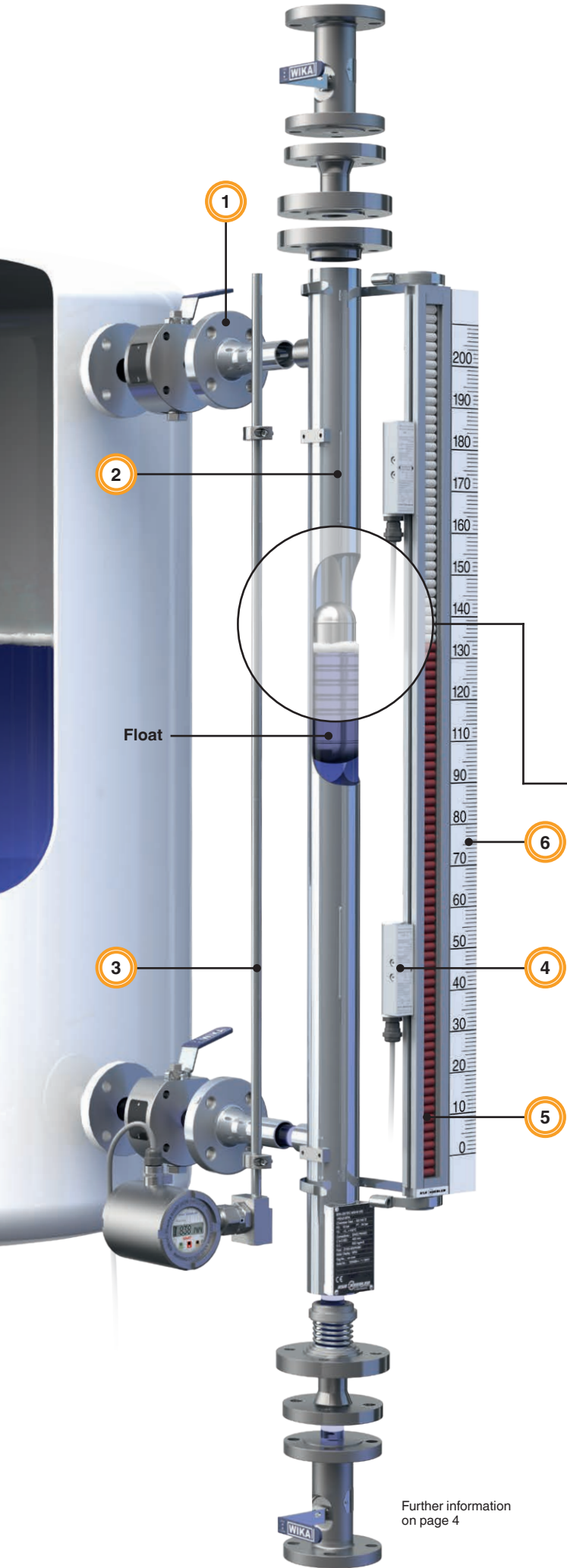

1 Connections to your process
The process connection, defined by you, represents an important interface to your process. It is welded to the bypass chamber to ensure permanent leak tightness.

2 Bypass chamber – communicating vessel
Levels in your vessel and also in the external pressure chamber equalise with each other in parallel. The magnetic float, designed to match the pressure, temperature, density and medium, moves up and down with the liquid.

Operating limits	
Operating temperature	T = -196 ... +450 °C
Operating pressure	P = Vacuum to 675 bar
Limit density	$\rho \geq 340 \text{ kg/m}^3$

Further information on page 4

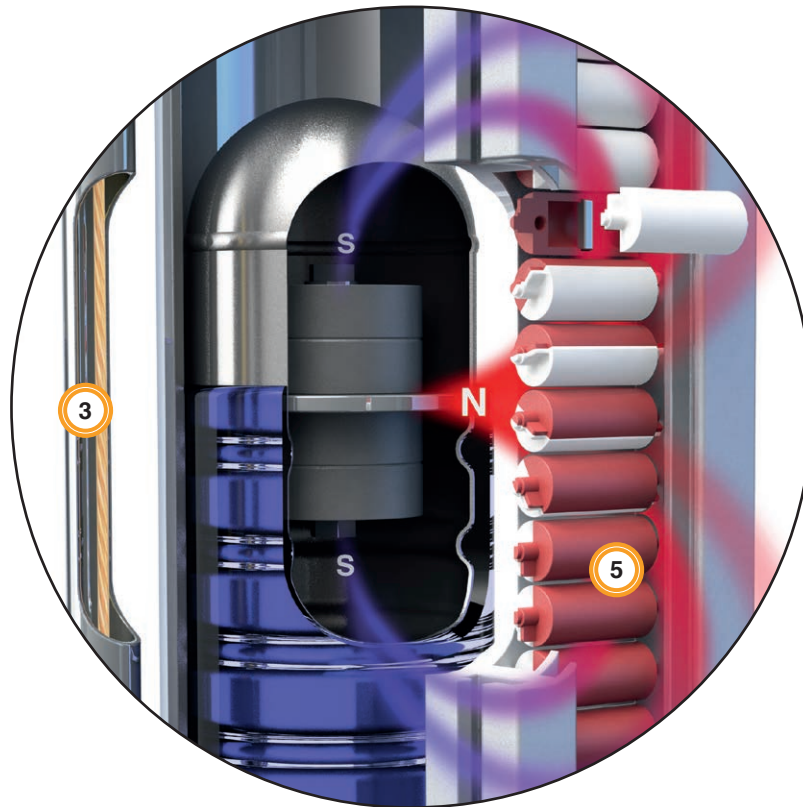

3 Reed/magnetostrictive level transmitter
 Through the magnetic field of the permanent magnetic system in the float, the exact level (measurement accuracy up to $< +0.5$ mm) is detected by the transmitters and transmitted remotely with an analogue/digital signal. The digital on-site display enables a direct view into the plant.

5 Magnetic display: visual level monitoring on-site
 The two-colour rollers or flaps are fitted with internal magnets. When they are in proximity to the magnetic field emitted from the float, they rotate 180° providing an indirect view of the current level. Thanks to the integrated mechanical interlocking, the accidental flipping of individual rollers is prevented.

4 Magnetic switch for limit value detection
 The compact fail-safe switches are located on the side of the gauge and offer multiple, adjustable alarm points.

6 Scaling
 The precise liquid level within your vessel is indicated via either an aluminium or stainless steel scale (selectable). The unit can be selected as %/cm/inch/litre/m³ etc.

➔ Accessories

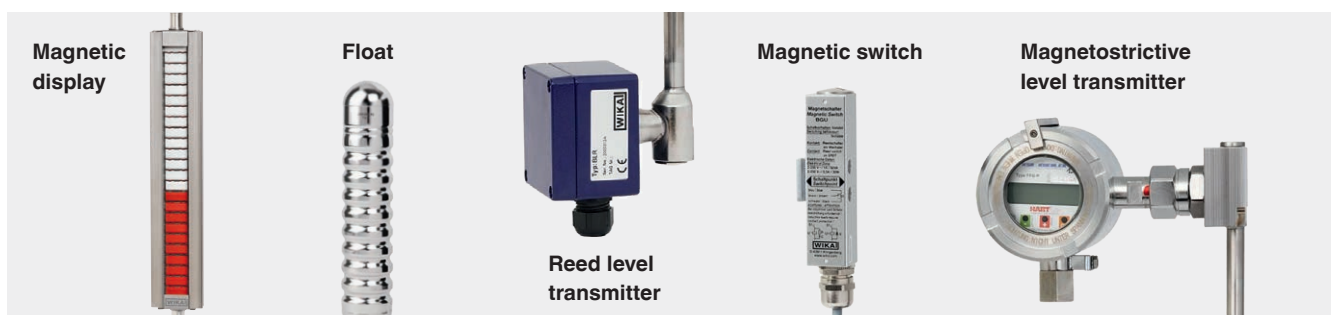

From process to measurement

Whether building a new plant on a “greenfield” site or upgrading existing production units (“brownfield”) – each application brings its own individual requirements in terms of connections, accessibility and fugitive emission limits. A fully process-oriented approach to development and manufacturing enables us to meet your specifications precisely.

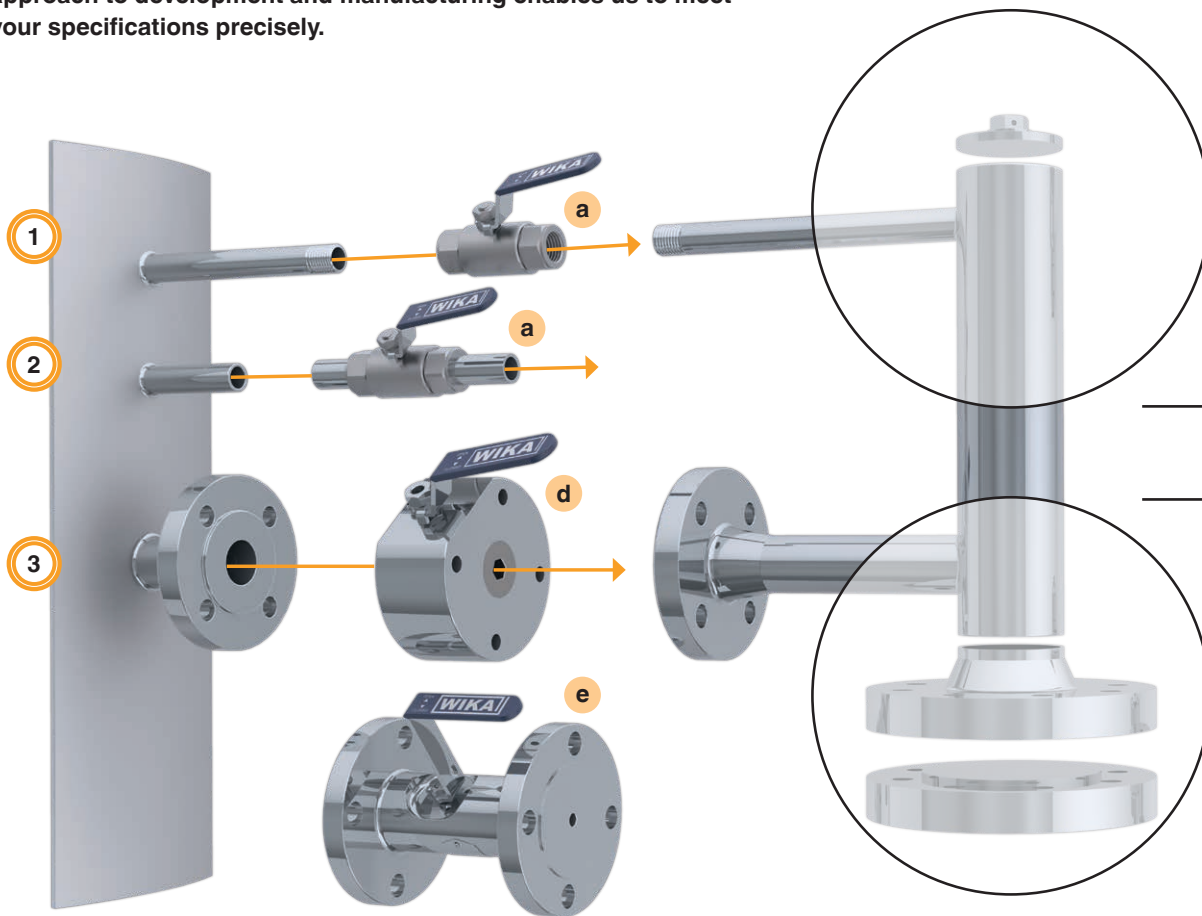

Process connection

Corresponding shut-off valves

1 Threaded/compression fitting

- Ball valve BV **a**
- Needle valve IV10 **b**
- High-pressure needle valve HPNV

2 Welded

- Ball valve BV **a**
- Needle valve IV10

3 Flanged

- Monoblock IBF1, IBF2, IBF3 **e**
- Monoball **d**
- Monoflange IVM

Available options depending on type of valve TA-Luft (VDI 2440) and ISO-15848-1 (option)



b



d

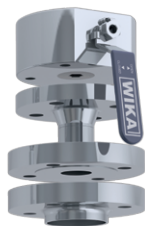

➔ Venting options*

Following the mechanical mounting, any trapped air is released during commissioning using the vent valves mounted at the highest point. Needle valves with compression fittings or flanged ball valves are common variants.

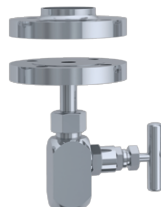

e



➔ Drainage options*

When preparing for any possible recurring testing, the chamber can be emptied and the pressure released by opening the drain valve. Compact needle valves are popular for low-viscosity fluids, while ball valves with a larger bore diameter may be the right choice for high-viscosity media.

* Further alternatives are possible.

Your service partner!

Your benefits

- Short downtimes
- Fast commissioning
- Ensuring process safety
- Compliance with local safety instructions
- Environmentally conscious handling



Does your requirement go beyond the scope of the services mentioned or are you interested in our worldwide range of services? **Please do not hesitate to contact us!**

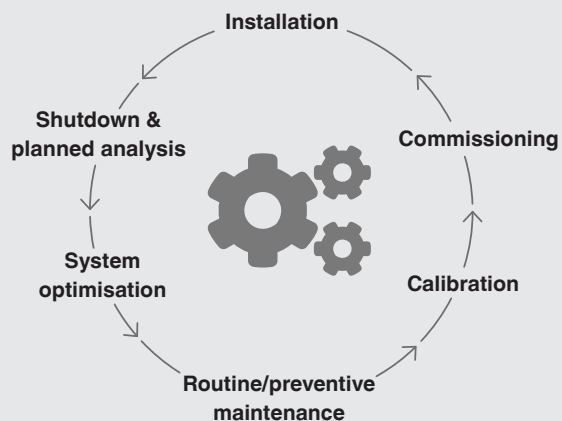

Further options

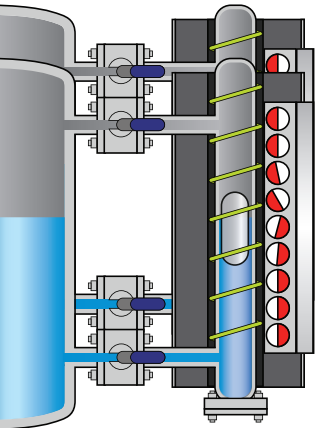

Energy saving – Thermal insulation/ hermetically sealed magnetic display/ non-icing extension/trace heating

Thermal insulation of the core tube is used in applications where the liquid must be maintained at a certain temperature. It helps to save energy.

- Avoiding excessive cooling of hot media
- Avoiding excessive heating of cold media

The hermetically sealed magnetic display works, even in condensing, frosty environments. The non-frost block gives the user a perfect view of the current level. Trace heating can be realised using steam in a double-chamber heating jacket or with an electric heating cable.

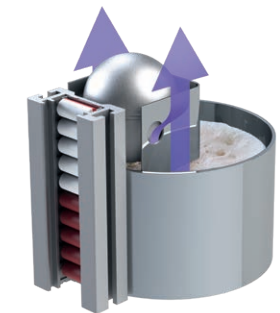
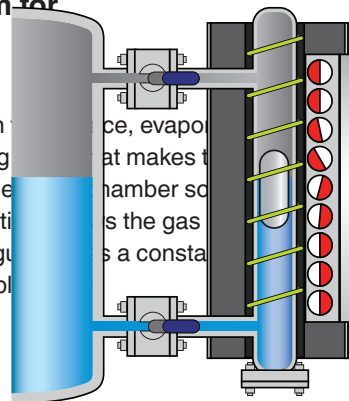
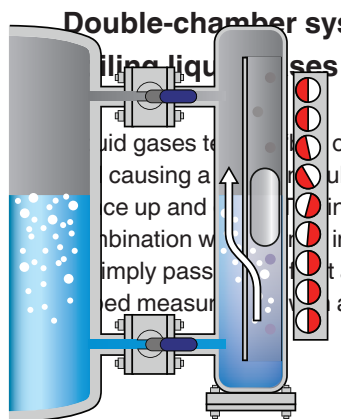
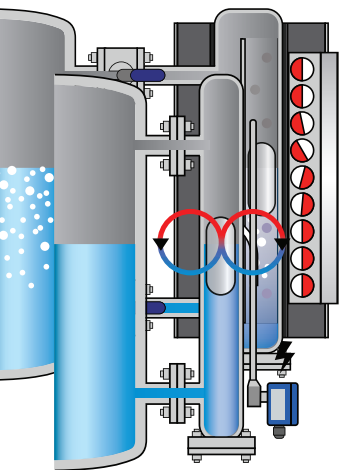
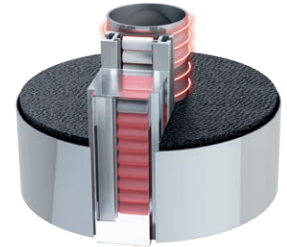

Double-chamber system for filling liquid

liquid gases to
causing a
ce up and
bination w
mply pass
ed measur

off" on
ce, evapor
at makes t
chamber so
s the gas
s a consta

Interface measurement for two or three phases

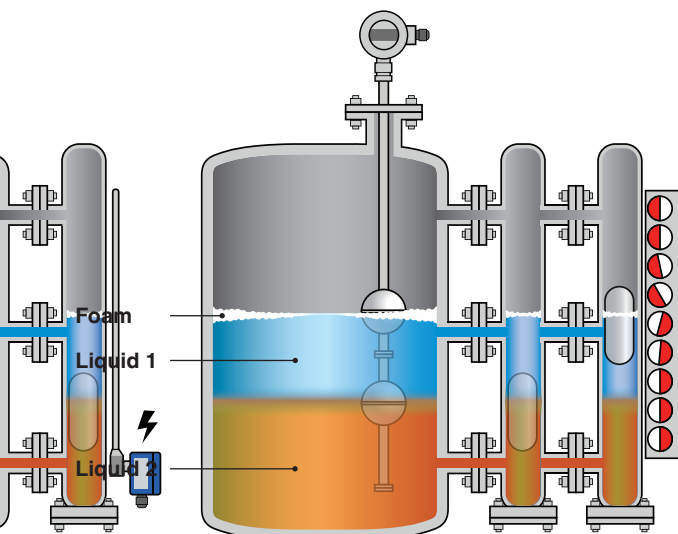

Installed from above or from the side

a real challenge. Foam on
ce can cau
ences. Small differences
between
bottom layers (liquid 1
2) may m
to detect the exact line
at systems, which have
proved over more than
sely ballasted floats, in
ps, ensure the best meas-
cesses worldwide. With
measuring system the interface layer and the
upper limit level are reliably transmitted as one single signal
with 4 ... 20 mA with HART®, or as 2 x 4 ... 20 mA.

Wide range of solutions

Does your safety concept require redundancy measurement using two different systems? Perhaps your vessel is only accessible via a top connection? Almost endless combinations, consisting of floats, reed/magnetostrictive transmitters, optoelectronic switches, radars, displacers and tuning forks, can be realised for the best result.



UTN

Top-mounted level indicator with external float especially for underground tanks.



Du Plus

Double-chamber system – parallel bypass chambers for redundant measurements in safety applications.



Ko Plus

Double chamber system – larger outside pipe containing two internal chambers offering measuring redundancy.



BZG

External chamber with radar or displacer without local magnetic display.

Integrated level sensors



Model FLM



Model FLR

Analogue reed-chain and magnetostrictive level transmitters constantly monitor the exact level in various liquid media applications.

➔ Operating limits

- Operating temperature:
T = -90 ... +450 °C
[-130 ... +842 °F]
- Operating pressure:
P = vacuum to 100 bar
[1,450.4 psi]
- Limit density: $\rho \geq 400 \text{ kg/m}^3$
[25.0 lbs/ft³]

Integrated and side-mounted switches



Model FLS

Level switch with up to 4 switch points, which give an alarm upon reaching the desired level.



Model ELS

Side-mounted level switches, typically installed in lubrication systems where direct integration of the switch is not possible.



Model OLS

Optoelectronic level switch with a temperature range of -269 ... +400 °C and a pressure range up to 500 bar. Typically used in measuring locations with small assembly dimensions.



Model HLS

Side-mounted level switch for horizontal installation.



WIKAI Alexander Wiegand SE & Co. KG
Alexander-Wiegand-Straße 30 · 63911 Klingenberg · Germany
Tel. +49 9372 132-0 · info@wika.de · www.wika.de