

Complete Industrial Networking Solutions for Power Automation Communication and Control

- Expertise in computing, communication, and control
- IEC 61850-3 compliance
- Easier to integrate with legacy protocols
- Well-suited for harsh environments



MOXA®



▶▶ Moxa at a Glance

▶ 22 Years of Networking Experience



Vision

To be a world-class leader in industrial-grade device networking solutions for automation

Mission

- **To Customers**

Provide value-added service and quality products.

- **To Business Partners**

Establish win-win business relationships based on trust and integrity.

- **To Employees**

Provide educational and career advancement opportunities, and share the company's success.

- **To Society**

Conduct regular educational programs and work to protect the environment.



Integrated Industrial Networking Solutions

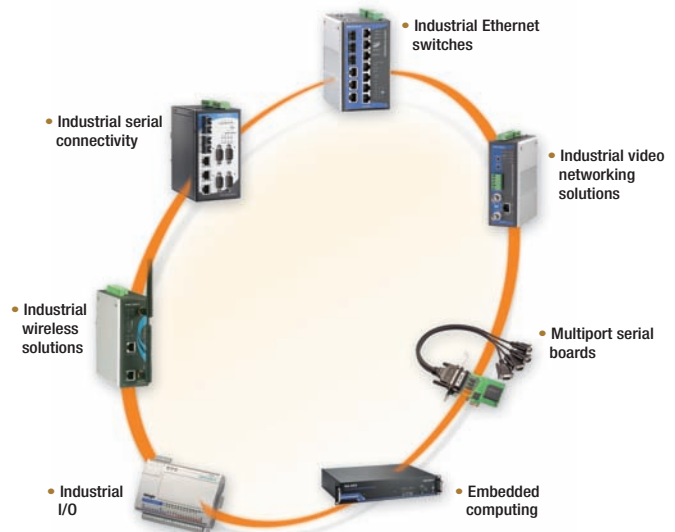

► A Brand You Can Trust



Awards

A Trusted Brand in Industrial Device Networking

For over twenty years, industrial systems integrators have relied on Moxa products in major device networking installations all over the world. Working with a network of certified distributors, Moxa offers world-class industrial networking products to systems integrators and value-added resellers in over 60 countries. Clients place great trust in Moxa's business and environmental practices, which are backed by ISO 9001:2000 and ISO 140001 certification. Moxa was established in 1987 and has offices in Europe, the United States, China, and Taiwan.

Dedicated R&D

Moxa's products have the advantage of being engineered in Taiwan, one of the world's centers of high-end electronics and information technology. With direct access to Taiwan's talented pool, Moxa has assembled an expert R&D team that is dedicated to innovative technologies and new standards for the industry.



International Recognition and Awards

2009 reddot Product Design Award

EDS-619 compact modular managed Ethernet switch

2008/2009 Trend 100 Products, SPS Magazine

PT-7828 IEC 61850-3 L3 Gigabit modular rackmount Ethernet switch

2008 Good Design Award

EDS-728 industrial Gigabit modular Ethernet switch

2007 Engineer's Choice Award, Control Engineering Magazine

W345 RISC-based wireless computer

2006 New Product Award, IEN Magazine

NPort W2004 wireless device server

2006 iF Product Design Award

EDS-726 industrial Gigabit modular Ethernet switch

2006 Engineer's Choice Award, Control Engineering Magazine

ioLogik E2210 Active Ethernet I/O server



reddot design award
winner 2009



► Power Automation

Trend Towards Smart Grids Foreseen in Power Automation

The global demand for electricity has been increasing considerably in recent years. It is expected that within the next 20 years, global demand will be two times higher than what it is now. To solve this crucial issue and balance the dilemma between economic growth and environmental protection, three approaches based on currently available communication technology can be used to reform the electrical power transmission infrastructure.

- **Clean Energy:** Integrate renewable energy such as wind power and solar power to reduce carbon emissions from burning coal.
- **Electric Infrastructure Efficiency:** Digitize power grids to reduce network energy consumption and enhance the energy efficiency of power generation, transmission, distribution, and consumption.
- **Electric Supply Stability:** Use real-time energy monitoring management to dispatch users' energy consumption status and fully balance the distribution of energy to stabilize the power supply and save energy.

These approaches provide ideal solutions that take energy, environmental protection, and economic growth into consideration to establish a real-time, stable, digitized, and intelligent Smart Grid.

Clean Energy

► Wind Power

Communication between wind turbine towers is a major issue since wind farms typically span vast distances that can go on for miles. Wind turbines are also prone to electrical interference so highly reliable anti-interference capabilities are also required to prevent unstable transmissions and data loss. Given these circumstances, it is essential for wind farms to employ rugged networking devices with long distance transmission capability for remote monitoring in harsh environments.

V481 Embedded Computer

The V481 monitors the status of the generator and the communication with field PLC devices and field site equipment. Designed with a low power consumption CPU, it does not need a fan for ventilation, and its compact design makes it a convenient alternative to traditional PCs.

NPort® S8000 Combo Switch / Serial Device Server

The NPort® S8000, which supports Moxa's own Turbo Ring redundancy protocol, can be used to connect both Ethernet and serial devices (PLCs, RTUs, etc.) to an Ethernet network.

► Wind Power

EDS-408A Managed Ethernet Switch

Designed for long distance wind farm networks, Moxa's slim rugged Ethernet switches offer three fiber ports that can be used to interconnect individual wind turbines and link to the tower control box. In addition, the fanless switches emphasize an extended temperature rating, EMI immunity, and redundant features to ensure stable operation on a wind farm.

VPort 351 Industrial Video Encoder

The VPort 351 video encoder is installed in wind turbines to allow engineers to remotely monitor the status of wind turbine operations from the control center.

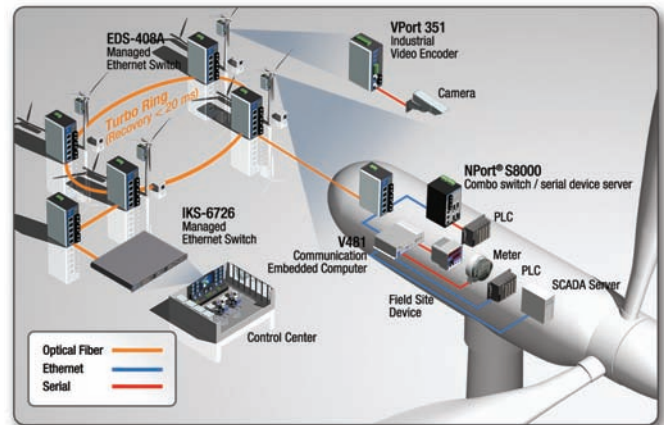

Why Moxa?

- Wind power generation systems are always installed in harsh environments with dust and wind. Under these circumstances, using a PC with a fan as the host platform will result in fan problems and system crashes. Moxa's compact and fanless embedded computers can be easily installed to replace the PC-based system.
- The recovery time of a Moxa Turbo Ring system is less than 20 ms.
- Moxa's EDS-408A industrial Ethernet switch supports 3 100FX ports, 2 fiber ports for redundant ring, and 1 fiber port for uplink to the wind turbine.
- The fiber model offers reliable communication over long distances and saves installation as well as cabling costs.
- Wind turbine applications require serial-to-Ethernet solutions that can operate reliably for years without interruption.
- The video encoder's built-in fiber port saves the cost of a media converter.



► Solar Energy

► Solar Energy

Solar Community

Solar energy communities rely primarily on solar power for their energy needs, and consequently it is important that such communities set up stable and reliable remote monitoring systems.

W406 and UC-7112 Embedded Computers

The W406 and UC-7112 EDGE wireless and communication embedded computers can be used as front-end communication computers that connect to the PV inverter, AI and counter input module, and solar power meter. They can also be used for remote monitoring, data acquisition, data logging, and protocol conversion.

OnCell G3150-HSDPA Cellular IP Gateway

The OnCell G3150-HSDPA cellular IP gateway makes use of high speed wireless UMTS/HSDPA technologies and provides secure TCP/IP connections to remote solar power meters over cellular networks.

ioLogik E1240 Remote Ethernet I/O

The ioLogik E1240 Ethernet I/O device with Active OPC Server proactively updates event messages to the control center with real-time stamps over the network, for effective integration with a real-time SCADA/HMI system.

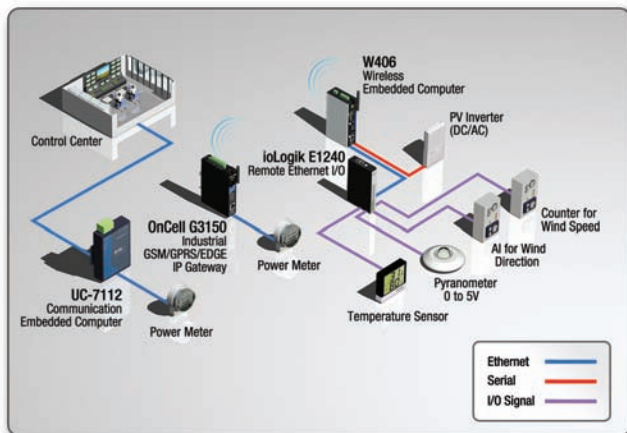

Solar Tracking System and Solar Transportation System

Solar power plants and other sophisticated solar power solutions use solar tracking systems to maximize the amount of solar energy that can be absorbed from the Sun's rays. The plants require embedded computers to serve as the

central controller for mapping and tracking the Sun. In addition, solar power can also be used to operate traffic signals, roadside displays, and various peripheral transportation devices.

V468 Embedded Computer

The V468 embedded computer can serve as the central controller for mapping and tracking the Sun in solar power plants, and sending data back and forth between the tracker and control center.

EDS-608 Managed Ethernet Switch

The award-winning EDS-600 series allows users to specify the port density and type (10/100/1000 copper and/or 100/1000 fiber ports) for flexible configuration.

CN2600 Terminal Server

The CN2600 terminal server is used for data collection and converts industrial serial devices into Ethernet devices and then sends data to the control center.

Why Moxa?

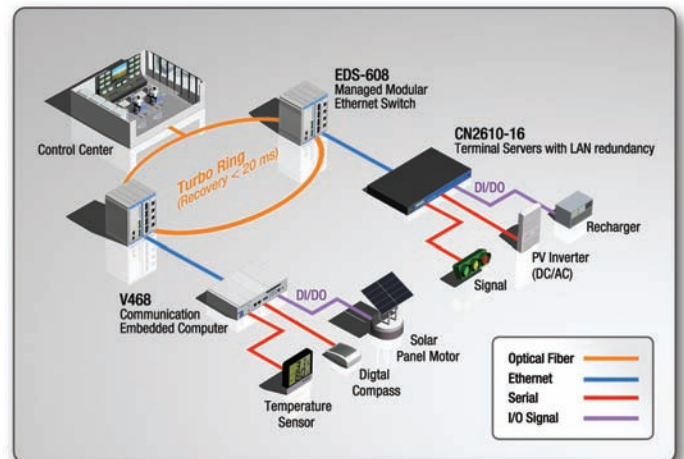

- Solar applications require low power solutions. Moxa's RISC-based embedded computers are energy efficient and their compact form factor makes them cost-effective and easy to install.
- Embedded computers for data acquisition and front-end computing, and Rcore embedded software platform for faster and easier programming.
- GSM/GPRS/EDGE IP gateways to extend communication—anytime, anywhere.
- Device servers for accurate data transmission supported by Moxa's Turbo Ring system with recovery time under 20 ms.



▶ Substation Automation

Electric Infrastructure Efficiency

▶ Substation Automation

Solar power plants use solar tracking systems to maximize the amount of solar energy that can be absorbed from the Sun's rays. The plants require embedded computers for the central controller to map and track the Sun. Solar power can also be used to operate traffic signals, roadside displays, and peripheral transportation devices.

DA-681 Embedded Computer

The DA-681 series x86-based embedded computer acts as a protocol gateway that handles multiple devices running different protocols for front-end computing and protocol conversion.

PT-7728 Rackmount Managed Ethernet Switch

The PT-7728 Gigabit modular Ethernet switch forms a network ring for redundancy, ensuring superior reliability for complex, high voltage substation environments through IEC 61850-3 and IEEE 1613 compliance.

IMC-101 and IMC-101G Media Converter

Field sites that are spread out over a wide area can benefit from fiber. The IMC series provides a cost-effective solution for extending transmission distance for remote management applications.

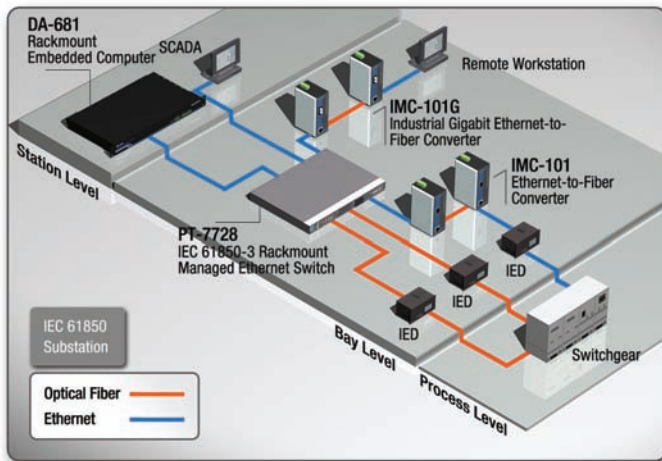

Why Moxa?

- Moxa's products are being used in several power automation applications.
- In front-end communication applications for power substations, the front-end processor requires a variety of communication interfaces to act as a protocol gateway. Moxa's x86-based embedded computers feature multiple connection options for greater networking versatility. Effective and readily available protocol conversion facilitates data communication between legacy devices using different protocols.
- Moxa's x86-based embedded computers are extremely stable and reliable and can be used as high performing backbone hosts for power substations.
- Single mode converters support a communication distance up to 40 km and multimode converters support up to 5 km.
- Moxa's PowerTrans series of IEC 61850-3 Ethernet switches is tailored for substation automation. Take advantage of superior EMI/RFI shielding, a -40 to +85°C operating range, and redundant media and power for challenging substation environments. Maximum flexibility is achieved by a modular rackmount design with high optical fiber and Gigabit port density.
- Ethernet media converters support 10/100BaseTX to 100BaseFX or 10/100/1000BaseTX to 1000BaseSX/LX/LHX/ZX.

▶ Automatic Meter Reading

Electric Supply Stability

▶ Automatic Meter Reading

A great deal of time and effort is consumed when engineers must make regular in-person visits to record every power meter in a network. An automated meter reading system can be established by using Moxa products to connect power meters to central management workstations.

W406, UC-8410, and IA261-I/IA262-I Embedded Computers

The main task performed by Moxa's W406 RISC-based EDGE wireless embedded computer and UC-8410 and IA261-I/IA262-I RISC-based embedded computers are data acquisition. These embedded computers store power usage data, perform front-end data acquisition and processing, and then transmit the data to centralized servers.

OnCell G3150 Cellular IP Gateway

The OnCell G3150 cellular IP gateway makes use of high speed wireless GSM/GPRS/EDGE technologies and provides secure TCP/IP connections to your remote power meters over cellular networks.

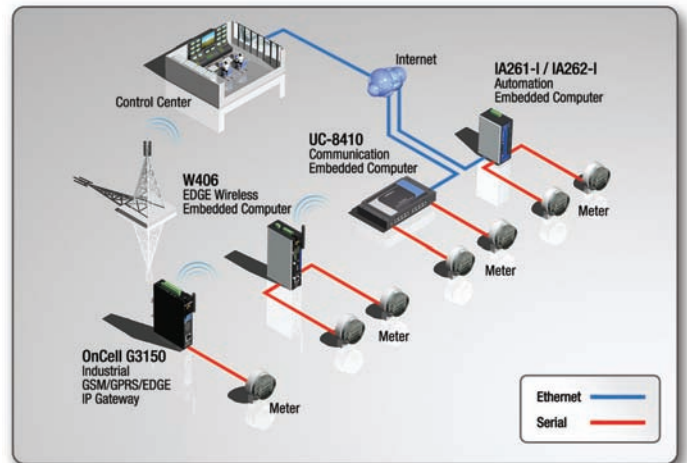

Why Moxa?

- This application requires front-end data acquisition and basic computing. It does not require the higher performance of x86-based systems. Moxa's RISC-based embedded computers offer a reliable and cost-effective solution for basic data acquisition and computing.
- The RISC-based computing environment shortens the programming learning curve and makes system management easier.





IEC 61850-3 & IEEE 1613 compliance







The IEC 61850-3 and IEEE 1613 standards define the highest standard of EMI immunity and error free communication requirements for network equipment used in substations. Moxa's substation Ethernet switches and embedded computers comply with the IEC 61850-3 and IEEE 1613 standards, guaranteeing that the computers are protected against various environmental factors.

Product Overview





Clean Energy—Wind Power

	EDS-408A 8-port industrial managed Ethernet switch with 3 fiber ports	<ul style="list-style-type: none"> 3 fiber optic ports (single/multi mode, SC/ST connectors) Turbo Ring, RSTP/STP (IEEE 802.1w/D) for Ethernet redundancy -40 to 75°C operating temperature
	IKS-6726 22+2G-port industrial rackmount modular Ethernet switch	<ul style="list-style-type: none"> High port density, rugged industrial-grade design Redundant power: universal 24/48 VDC or 110/220 VDC/VAC power supplies -40 to 75°C operating temperature
	V481 x86-based communication embedded computer	<ul style="list-style-type: none"> 8 software-selectable RS-232/422/485 serial ports Serial port speed from 50 bps to 921.6 Kbps, supporting non-standard baudrates 10/100 and 10/100/1000 Mbps LANs for network redundancy
	NPort S8000 Combo Switch / Serial Device Server	<ul style="list-style-type: none"> 4-port RS-232/422/485 serial device server with 2 KV (DC) isolation protection 5-port managed Ethernet switch with Turbo Ring® (recovery time < 20 ms) or RSTP/STP (IEEE 802.1w/D) supported Surge protection for serial, power, and Ethernet
	VPort 351 Full motion, 1-channel MJPEG/MPEG4 industrial video encoder	<ul style="list-style-type: none"> Industrial design with -40 to 75°C operating temperature and fiber optic Ethernet port Video stream up to 30 frames/sec at full D1 (720 x 480) resolution Pre/post-alarm video recording function for advanced surveillance



Clean Energy—Solar Power

	EDS-608 8-port industrial compact modular Ethernet switch	<ul style="list-style-type: none"> Compact modular design for tight space and flexible solution Turbo Ring, RSTP/STP (IEEE 802.1w/D) for Ethernet redundancy -40 to 75°C operating temperature
	OnCell G3150-HSDPA GSM/GPRS/EDGE IP Gateway	<ul style="list-style-type: none"> UMTS/HSDPA and GSM/GPRS/EDGE compliant Easy connection with versatile operation modes: Reverse Real COM Redundant DC power input
	ioLogik E1240 Daisy-chain Remote Ethernet I/O with 8 AIs	<ul style="list-style-type: none"> Built-in 2-port Ethernet switch Easy integration with SCADA using Active OPC Server Painless migration with user definable Modbus address
	CN2600 Series 8/16-port RS-232/422/485 terminal servers with LAN redundancy	<ul style="list-style-type: none"> Redundant COM function available when both LANs are active Dual-LAN cards with two independent MAC address and IP addresses Dual AC power inputs
	W406 RISC-based GSM/GPRS/EDGE wireless embedded computer	<ul style="list-style-type: none"> GSM 850/900/1800/1900 MHz supported, GPRS/EDGE Class 12 supported Two software selectable RS-232/422/485 serial ports 4 DIs, 4 DOs

Electric Infrastructure Efficiency

	PT-7728 IEC 61850-3 24+4G-port rackmount Gigabit modular managed Ethernet switch	<ul style="list-style-type: none"> Fully compliant with IEC 61850-3 and IEEE 1613 Various media modules: RJ45, fiber, SFP, and M12 ports Isolated redundant power inputs with universal 24/48 VDC or 110/220 VDC/VAC inputs
	DA-681 x86-based rackmount embedded computer	<ul style="list-style-type: none"> Dual power for network redundancy (DP/DPP models only) 6 10/100 Mbps Ethernet ports for network redundancy Meets IEC 61850-3 certification (DPP model only)
	IMC-101 Series Industrial 10/100BaseT(X) to 100BaseFX media converters	<ul style="list-style-type: none"> 10/100BaseT(X) auto-negotiation and auto-MDI/MDI-X Link Fault Pass-Through (LFP) Power failure, port break alarm by relay output
	IMC-101G Industrial Gigabit Ethernet to fiber media converter	<ul style="list-style-type: none"> 10/100/1000BaseT(X) and 1000BaseSX/LX/LHX/ZX supported Link Fault Pass-Through (LFP) Power failure, port break alarm by relay output

Electric Supply Stability

	OnCell G3150 GSM/GPRS/EDGE IP Gateway	<ul style="list-style-type: none"> 2 digital inputs and 1 relay output for remote alarm Connect both Ethernet and serial devices to cellular networks Centralized private IP management software
	UC-8410 RISC-based communication embedded computer	<ul style="list-style-type: none"> Customized flexible expansion for greater versatility 8 RS-232/422/485 serial ports; 4+4 DI/DO channels 16 MB NOR Flash onboard to store OS, 32 MB NAND Flash onboard for data storage
	IA261-1/IA262-1 RISC-based automation embedded computer	<ul style="list-style-type: none"> Patented "H-Type" heat dissipation 4 RS-232/422/485 serial ports, 8+8 DI/DO channels, up to 30 VDC Dual LAN ports for network redundancy with VGA interface for field site monitoring

► Stringent Quality Control



24-hour Dynamic Burn-in

24-hour Dynamic Burn-in and 5-year Warranty

Moxa's products have passed a series of strict design and manufacturing tests, including ESD, surge/EFT, wide temperature, shock and vibration, and many more. In particular, a 24-hour dynamic burn-in test must be conducted to guarantee the ultimate industrial-grade quality and reliability.

Commitment to Quality and Environment

Moxa strives for continual improvement and innovation, adheres to the company's quality and environmental management system, complies with all relevant environmental legislation and regulations, and stringent industry standards.



Sales and Service Network

Global Operation

- Distributors located in more than 60 countries around the world
- Headquarters in Taiwan, and branch offices on three continents



MOXA®

Moxa Inc.
www.moxa.com
info@moxa.com

Moxa Americas
Toll-free: 1-888-MOXA-USA
(1-888-669-2872)
Tel: +1-714-528-6777
Fax: +1-714-528-6778
www.moxa.com
usa@moxa.com

Moxa China
Shanghai Office
Tel: +86-21-5258-9955
Fax: +86-21-5258-5505
www.moxa.com.cn
china@moxa.com

Moxa Europe
Tel: +49-89-3 70 03 99-0
Fax: +49-89-3 70 03 99-99
www.moxa.com
europe@moxa.com

Beijing Office
Tel: +86-10-6872-3959/60/61
Fax: +86-10-6872-3958
www.moxa.com.cn
china@moxa.com

Moxa Asia-Pacific
Tel: +886-2-8919-1230
Fax: +886-2-8919-1231
www.moxa.com
asia@moxa.com

Shenzhen Office
Tel: +86-755-8368-4084/94
Fax: +86-755-8368-4148
www.moxa.com.cn
china@moxa.com